

# Operation & Maintenance Manual

**MARINE GENERATOR ENGINE**

**L136, L136T, L136TL, L136TI, L086TI,  
AD136, AD136T, AD136TI, AD086TI**

















## FOREWORD

This manual is designed to serve as an instruction for the Operation & Maintenance of marine propulsion engines **L136/T/TI/086TI** and marine auxiliary engines **AD136/T/TI/086TI**, combined in one book.

The first half is explained for operation and the latter half is described for maintenance like disassembling, inspecting and re-assembling etc in order to help an understanding for the maintenance procedure more easily. To keep the best performance and the durability of engine for a long time, **CORRECT OPERATION** and **PROPER MAINTENANCE** are essential.

In this manual, the following symbols are used to indicate the type of service operations to be performed.

	Removal		Adjustment
	Installation		Cleaning
	Disassembly		Pay close attention-Important
	Reassembly		Tighten to specified torque
	Align the marks		Use special tools of manufacturer's
	Directional Indication		Lubricate with oil
	Inspection		Lubricate with grease
	Measurement		

Some figures of this manual may be different from the actual appearance of the engine because of explaining them with the representative figure among these models.

If you have any question or recommendation in connection with this manual, please do not hesitate to contact our head office, dealers or authorized service shops near by your location for any services.

For the last, the content of this manual instruction may be changed without prior notice for some quality improvement. Thank you.

2025. 12

950106-064016EN

**HD Construction Equipment**

- \* Items exempted from warranty coverage
  - Malfunctions resulting from failing to comply with the proper handling instructions, regular inspections, and machine storage techniques specified in the user manual
  - Malfunctions resulting from failing to have the machine repaired at a designated dealer or center, or resulting from the use of non-genuine parts
  - Malfunctions resulting from unauthorized modifications, changes, or external hardware
  - Malfunctions resulting from incorrect operation by the user, delayed repairs, accidents, and natural disasters
- \* The contents of this operation and maintenance manual are the exclusive property of HD Construction Equipment. Any unauthorized reproduction, printing and distribution thereof are strictly prohibited.

# CONTENTS

<b>1. Specification.....</b>	<b>1</b>
1.1. Engine Specification .....	1
1.2. Engine Aspects .....	5
1.3. Engine Performance Curve .....	7
1.4. Engine Model & Serial Number .....	8
<b>2. Safety Regulations.....</b>	<b>9</b>
2.1. General Notes .....	9
2.2. Regulations Designed to Prevent Accidents with Injury to Persons .....	9
2.3. Regulations Designed to Prevent Damage to Engine and Premature Wear.....	11
2.4. Regulations Designed to Prevent Pollution .....	12
2.5. Notes on Safety in Handling Used Engine Oil .....	12
2.6. Cause of Electrolytic Corrosion .....	13
<b>3. Commissioning and Operation.....</b>	<b>15</b>
3.1. Inspections Before Operation .....	15
3.2. Starting .....	18
3.3. Engine Break-in .....	18
3.4. Inspection After Starting .....	21
3.5. Check After Initial 50 Hours Operation .....	21
3.6. Operation in Winter Time .....	22
3.7. Tuning the Engine .....	22
<b>4. Maintenance and Care.....</b>	<b>23</b>
4.1. General Instructions .....	23
4.2. Periodical Inspection & Maintenance .....	24
4.3. Cooling System .....	25
4.4. Lubrication System .....	32
4.5. Intake & Exhaust System .....	35
4.6. Fuel System .....	38
4.7. Electric System.....	41
4.8. Cylinder .....	42
4.9. Engine Preservation Points for a Long Time .....	43
4.10. Management for Sunken Engine.....	44
<b>5. Main Accessory Parts.....</b>	<b>45</b>
5.1. Reduction Gear .....	45
5.2. Front Power Take-Off (F.P.T.O) .....	47
5.3. Propeller Selection .....	48
5.4. Electric System.....	49
<b>6. Disassembly and Assembly of Major Components.....</b>	<b>53</b>
6.1. Disassembly .....	53
6.2. Inspection .....	67
6.3. Engine Re-assembly .....	84
6.4. Break-in After Maintenance .....	107

<b>7. Main Parts Maintenance</b> .....	<b>109</b>
7.1. Lubricating System .....	109
7.2. Cooling System .....	111
7.3. Fuel System .....	112
7.4. Turbocharger .....	131
<b>8. Trouble Shooting</b> .....	<b>153</b>
<b>9. Tightening Torque</b> .....	<b>159</b>
<b>10. Engine Assembly Tolerance</b> .....	<b>161</b>

# 1. Specification

## 1.1. Engine Specification

### 1.1.1. L136/T/TL/TI

Spec.	Model	Units	L136	L136T	L136TL	L136TI
Engine type			4 cycle, in line, direct-injection, water cooled, aspirated naturally	4 cycle, in line, direct-injection, water cooled with turbo charger		4 cycle, in line, direct-injection, water cooled with turbo charger & inter-cooler
Rating output (B.H.P)		PS (kW)/rpm	160 (118)/2,200	200 (147)/2,200	240 (177)/2,500	230 (169)/2,200
Displacement		cc	8,071			
Cyl. No. – bore (ø) x stroke		mm	6 - ø111 x 139			
Valve clearance at cold		mm	In: 0.3, Ex: 0.3			
Low idling		rpm	725 ±25			
No load max.		rpm	Below 2,420	Below 2,400	Below 2,750	Below 2,400
Mean effective pressure		kg/cm <sup>2</sup>	8.07	10.14	10.71	11.66
Mean piston speed		m/sec.	10.19		11.58	10.19
Compression ratio			17.6 : 1	16.7 : 1		
Firing order			1-5-3-6-2-4			
Comp. pressure (at 200 rpm)		kg/cm <sup>2</sup>	28 (Initial condition)			
Governor type of injection pump			Mechanical all speed (R.S.V)			
Fuel consumption		g/PS.h	165	165	172	164
		liter/h	32	39.5	49.4	45.3
Injection timing (B.T.D.C)		deg.	22° ±1°	18° ±1°		14° ±1°
Fuel Inj. nozzle opening pressure		kg/cm <sup>2</sup>	214	214 + 8		
Starting system			Electric starting by starter motor			
Starter motor capacity		V - kW	24 – 4.5			
Alternator capacity		V - A	24 – 80			
Battery		V - Ah	24 – 100			
Cooling system			Indirect sea water cooling with heat exchanger			
Cooling water capacity		lit	Max: 25, Min: 23	Max: 27, Min: 25		
Fresh water pump type			Centrifugal type, driven by V-belt			
Sea water pump type			Rubber impeller type driven by gear			
Lub. Oil (Engine)	Pan capacity	lit	Max: 23, Min: 17 (Engine total: 25)			
	Pressure	kg/cm <sup>2</sup>	Full: 3.5, Idle: 1.5	Full: 3.5, Idle: 1.2		
Marine gear	Model		DMT90A (Dong-I)			DMT110A (Dong-I)
	Gear ratio		1.61/2.06/2.45/2.82/3.12/3.46			1.77/2.09/2.42/2.82/3.19
Direction of revolution	Crankshaft		Counter clockwise viewed from stern side			
	Propeller		Clockwise viewed from stern side			
Engine size (L x W x H)	Without M.G	mm	1,182 x 770 x 925			1,182 x 825 x 925
	With M.G	mm	1,542 x 770 x 963			1,552 x 825 x 1,027
Engine dry weight	Without M.G	kg	743	748		773
	With M.G	kg	928	938		994

**1.1.2. L086TIH/TIM/TIL**

Model		Units	L086TIH	L086TIM	L086TIL
Spec.					
Engine type			4 cycle, in line, direct- injection, water cooled with wet-turbo charger & inter-cooler		
Rating output (B.H.P)	PS (kW)/rpm		285 (210)/2,100	315 (232)/2,300	360(265)/2,500
Displacement	cc		8,071		
Cyl. No. – bore (ø) x stroke	mm		6 - ø111 x 139		
Valve clearance at cold	mm		In: 0.3, Ex: 0.3		
Low idling	rpm		750 ±25		
No load max.	rpm		Below 2,310	Below 2,530	Below 2,750
Mean effective pressure	kg/cm <sup>2</sup>		15.14	14.55	16.06
Mean piston speed	m/sec.		9.73	10.66	11.58
Compression ratio			16.7 : 1		15.3 : 1
Firing order			1-5-3-6-2-4		
Comp. pressure (at 200 rpm)	kg/cm <sup>2</sup>		28 (Initial condition)		
Governor type of injection pump			Mechanical all speed (R.S.V)		
Fuel consumption	g/PS.h		157	177	171
	liter/h		53.9	67.0	74.2
Injection timing (B.T.D.C)	deg.		15° ±1°		
Fuel Inj. nozzle opening pressure	kg/cm <sup>2</sup>		214		
Starting system			Electric starting by starter motor		
Starter motor capacity	V - kW		24 – 4.5		
Alternator capacity	V - A		24 – 80		
Battery	V - Ah		24 – 100		
Cooling system			Indirect sea water cooling with heat exchanger		
Cooling water capacity	lit		Max: 27, Min: 25		
Fresh water pump type			Centrifugal type, driven by V-belt		
Sea water pump type			Rubber impeller type driven by gear		
Lub. Oil (Engine)	Pan capacity	lit	Max: 23, Min: 17 (Engine total: 25)		
	Pressure	kg/cm <sup>2</sup>	Full: 3.5, Idle: 1.2		
Direction of revolution	Crankshaft		DMT110A (Dong-I)		
	Propeller		1.77/2.09/2.42/2.82/3.19		
Direction of revolution	Crankshaft		Counter clockwise viewed from stern side		
	Propeller		Clockwise viewed from stern side		
Engine size (L x W x H)	Without M.G	mm	1,182 x 825 x 962		
	With M.G	mm	1,552 x 825 x 1,062		
Engine dry weight	Without M.G	kg	790		
	With M.G	kg	1,015		

### 1.1.3. AD136/T/TI /086TI

Spec.		Model	Units	Auxiliary			
				AD136	AD136T	AD136TI	AD086TI
Engine type			4 cycle, in line, direct- injection, water cooled naturally aspirated	4 cycle, in line, direct- injection, water cooled with turbo charger	4 cycle, in line, direct- injection, water cooled with turbo charger & inter-cooler	4 cycle, in line, direct- injection, water cooled with wet-turbo charger & inter-cooler	
Rating output (B.H.P)	50 Hz	PS (kW)/	105 (77)/1,500 (AD136F)	145 (107)/1,500 (AD136TF)	157 (115)/1,500 (AD136TIF)	205 (151)/1,500 (AD086TIF)	
	60 Hz	rpm	126 (93)/1,800 (AD136S)	170 (125)/1,800 (AD136TS)	188 (138)/1,800 (AD136TIS)	253 (186)/1,800 (AD086TIS)	
Displacement		cc	8,071				
Cylinder No. – bore (ø) x stroke		mm	6 - ø111 x 139				
Valve clearance at cold		mm	In: 0.3, Ex: 0.3				
Low idling		rpm	800 ±50				
No load max.		rpm	Mechanical governor: 1,575 (52.5 Hz)/1,890(63 Hz)				
			Electric governor: 1,500 (50 Hz)/1,800(60 Hz)				
Mean effective press. (Initial)		kg/cm <sup>2</sup>	7.81/7.81	10.78/10.53	11.65/11.65	15.24/15.67	
Mean piston speed		m/sec.	6.95/8.34				
Compression ratio			17.6 : 1	16.7 : 1			
Comp. press. (at 200 rpm)		kg/cm <sup>2</sup>	About 28 (Initial condition)				
Governor type of inj. pump			Electric governor				
Fuel consumption (SG: 0.832 g/cc)		g/PS.h	160/160	153/155	153/153	150/151	
		liter/h	20/24	27/32	29/34	37/46	
Injection timing (B.T.D.C)		deg.	22° ±1°	18° ±1°	14° ±1°	15° ±1°	
Fuel Inj. nozzle opening pressure		kg/cm <sup>2</sup>	224				
Starting system			Electric starting by starter motor				
Starter motor capacity		V - kW	24 – 4.5				
Alternator capacity		V - A	24 – 80				
Battery		V - Ah	24V– 100				
Cooling system			Indirect cooling by sea water with heat exchanger				
Cooling water capacity		lit	Max: 25, Min: 23				
Fresh water pump type			Centrifugal type, driven by V-belt				
Sea water pump type			Rubber impeller type driven by gear				
Lub. Oil (Engine)	Pan capacity	lit	Max: 23, Min: 17 (Engine total: 25)				
	Pressure	kg/cm <sup>2</sup>	Full: 3.5, Idle: 1.2				
Revolution of crankshaft			Counter clockwise viewed from stern side				
Engine only size (L x W x H)		mm	1,182 x 770 x 925		1,182 x 825 x 925	1,182 x 825 x 962	
Engine only (Dry weight)		kg	735	748	773	790	

#### 1.1.4. AD136TI/AD086TI

Spec.		Model	Units	Emergency	
				AD136TI	AD086TI
Engine type				4 cycle, in line, direct- injection, water cooled with turbo charger & inter-cooler	4 cycle, in line, direct- injection, water cooled with wet-turbo charger & inter-cooler
Rating output (B.H.P)	60 Hz	PS (kW)/rpm		188 (138)/1,800 (AD136TIS)	253 (186)/1,800 (AD086TIS)
Displacement		cc	8,071		
Cylinder No. – bore (ø) x stroke		mm	6 - ø111 x 139		
Valve clearance at cold		mm	In: 0.3, Ex: 0.3		
Low idling		rpm	800 ±50		
No load max.		rpm	Mechanical governor: 1,575 (52.5 Hz)/1,890(63 Hz)		
			Electric governor: 1,500 (50 Hz)/1,800(60 Hz)		
Mean effective press. (Initial)		kg/cm <sup>2</sup>	11.65/11.65	15.24/15.67	
Mean piston speed		m/sec.	6.95/8.34		
Compression ratio			16.7 : 1		
Comp. press. (at 200 rpm)		kg/cm <sup>2</sup>	About 28 (Initial condition)		
Governor type of inj. pump			Electric governor		
Fuel consumption (SG: 0.832 g/cc)		g/PS.h	168	155	
		liter/h	38	47	
Injection timing (B.T.D.C)		deg.	14° ±1°	15° ±1°	
Fuel Inj. nozzle opening pressure		kg/cm <sup>2</sup>	224		
Starting system			Electric starting by starter motor		
Starter motor capacity		V - kW	24 – 4.5		
Alternator capacity		V - A	24 – 80		
Battery		V - Ah	24V– 100		
Cooling system			Indirect cooling by sea water with heat exchanger		
Cooling water capacity		lit	Max: 25, Min: 23		
Fresh water pump type			Centrifugal type, driven by V-belt		
Sea water pump type			Rubber impeller type driven by gear		
Lub. Oil (Engine)	Pan capacity	lit	Max: 23, Min: 17 (Engine total: 25)		
	Pressure	kg/cm <sup>2</sup>	Full: 3.5, Idle: 1.2		
Revolution of crankshaft			Counter clockwise viewed from stern side		
Engine only size (L x W x H)		mm	1,182 x 825 x 925	1,182 x 825 x 962	
Engine only (Dry weight)		kg	773	790	



**NOTE:** Fuel consumption data is based on engine test data, and Fuel efficiency may difference depending on vessel driving habits and sea conditions.

## 1.2. Engine Aspects

**NOTE:** The images shown represent the standard model; they do not include all models.

### 1.2.1. Engine Sectional Drawing

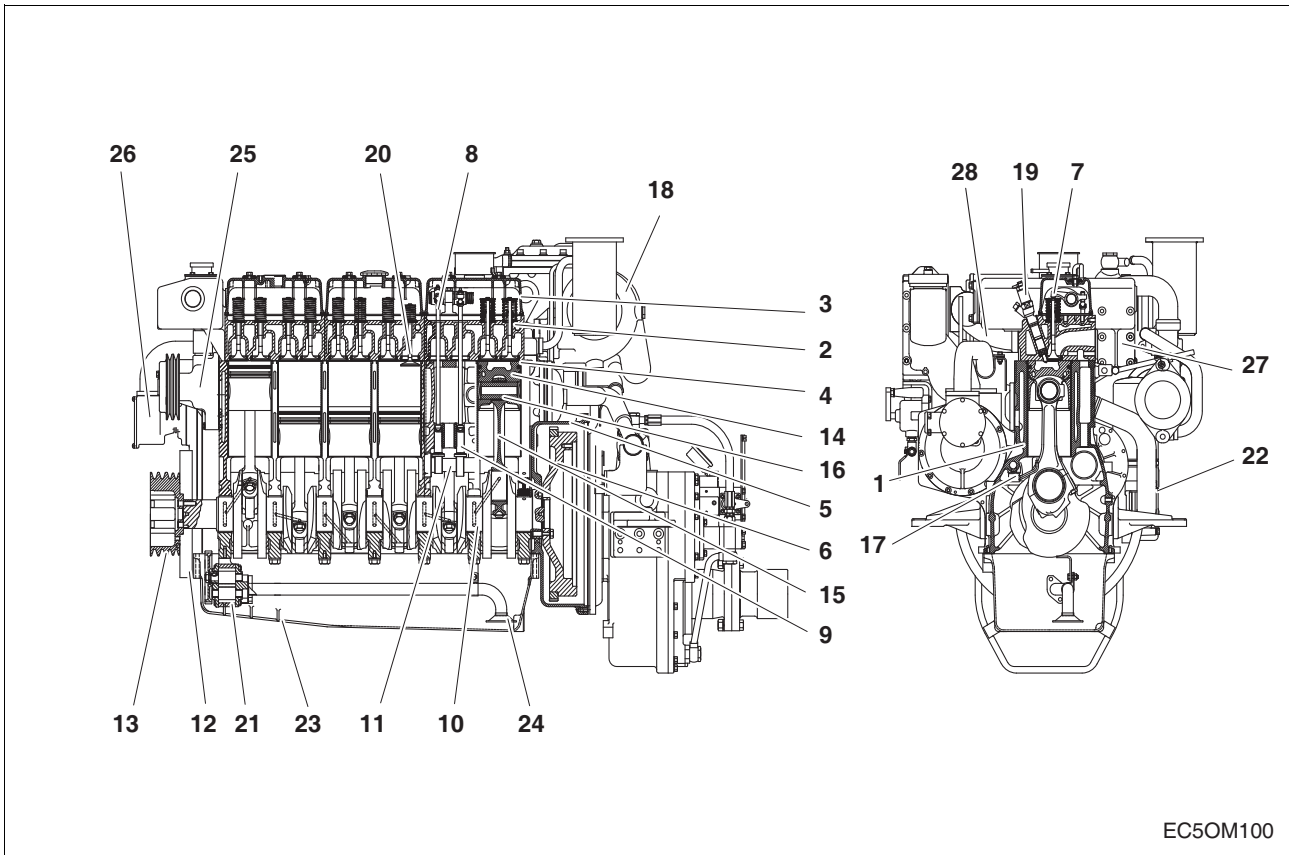

- |                        |                                 |                      |
|------------------------|---------------------------------|----------------------|
| 1. Cylinder block      | 11. Camshaft                    | 21. Oil pump         |
| 2. Cylinder head       | 12. Vibration damper            | 22. Oil cooler       |
| 3. Cylinder head cover | 13. Camshaft pulley             | 23. Oil pan          |
| 4. Cylinder liner      | 14. Piston                      | 24. Oil suction pipe |
| 5. Flywheel housing    | 15. Connecting rod              | 25. Water pump       |
| 6. Flywheel            | 16. Piston pin                  | 26. Sea water pump   |
| 7. Rocker arm          | 17. Piston cooling spray nozzle | 27. Exhaust manifold |
| 8. Push rod            | 18. Turbocharger                | 28. Intake manifold  |
| 9. Tappet              | 19. Multi-hole injection nozzle |                      |
| 10. Crankshaft         | 20. Valve                       |                      |

## 1.2.2. Engine Assembly

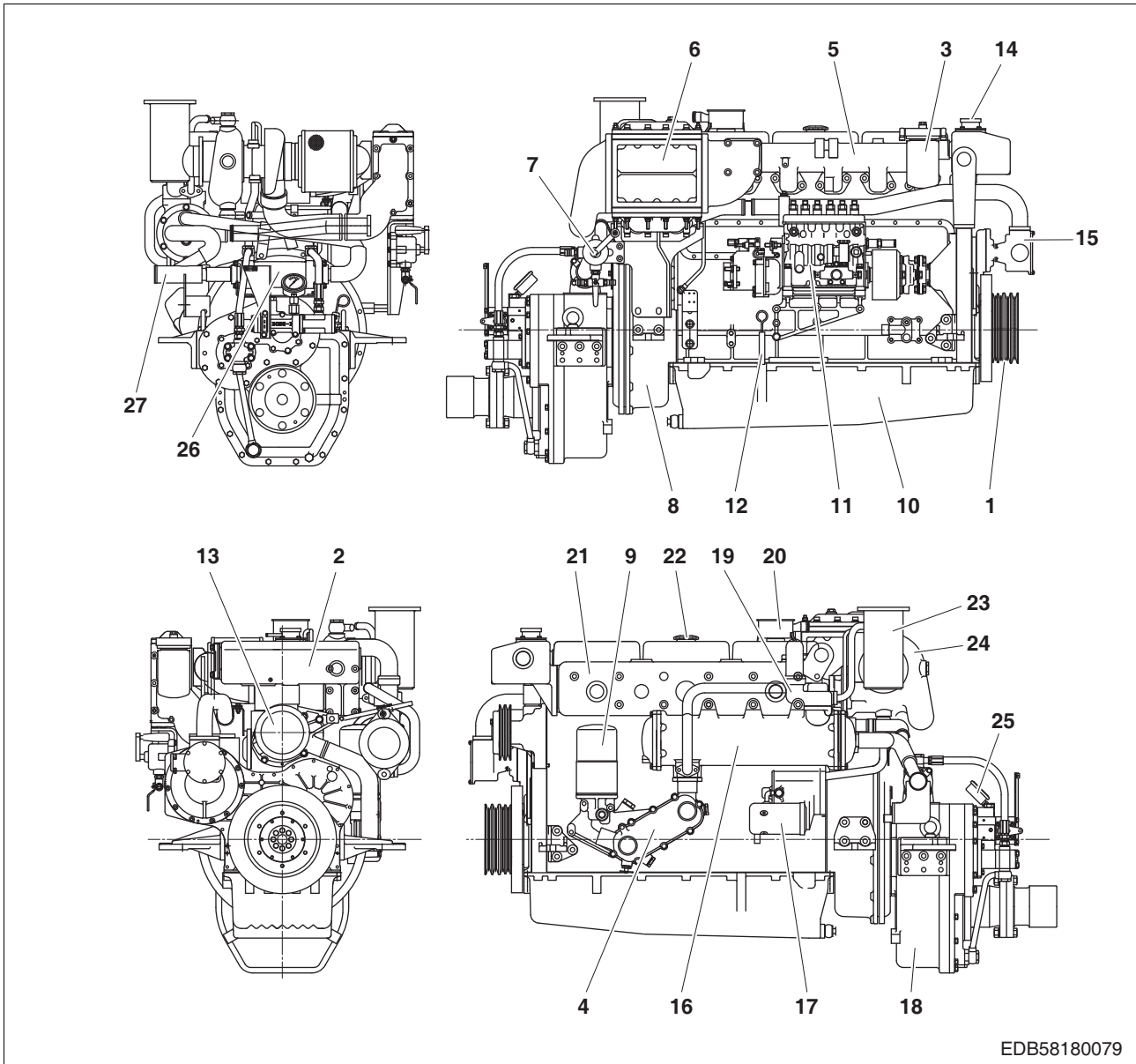

EDB58180079

- |                     |                                  |                             |
|---------------------|----------------------------------|-----------------------------|
| 1. Crank pulley     | 10. Oil pan                      | 19. Thermostat housing      |
| 2. Expansion tank   | 11. Injection pump ass'y         | 20. Breather ass'y          |
| 3. Fuel filter      | 12. Oil guide tube & level gauge | 21. Exhaust manifold        |
| 4. Oil cooler cover | 13. Water pump                   | 22. Oil filler cap          |
| 5. Intake manifold  | 14. Fresh water filler cap       | 23. Exhaust outlet pipe     |
| 6. Intercooler      | 15. Sea water pump               | 24. Turbocharger (wet)      |
| 7. Oil drain pump   | 16. Heat exchange ass'y          | 25. Clutch oil press. gauge |
| 8. Flywheel housing | 17. Starter                      | 26. Marine gear oil cooler  |
| 9. Oil filter       | 18. Marine gear ass'y            | 27. Sea water outlet pipe   |

### 1.3. Engine Performance Curve

#### 1.3.1. L136/L136T/L136TI/L136TL

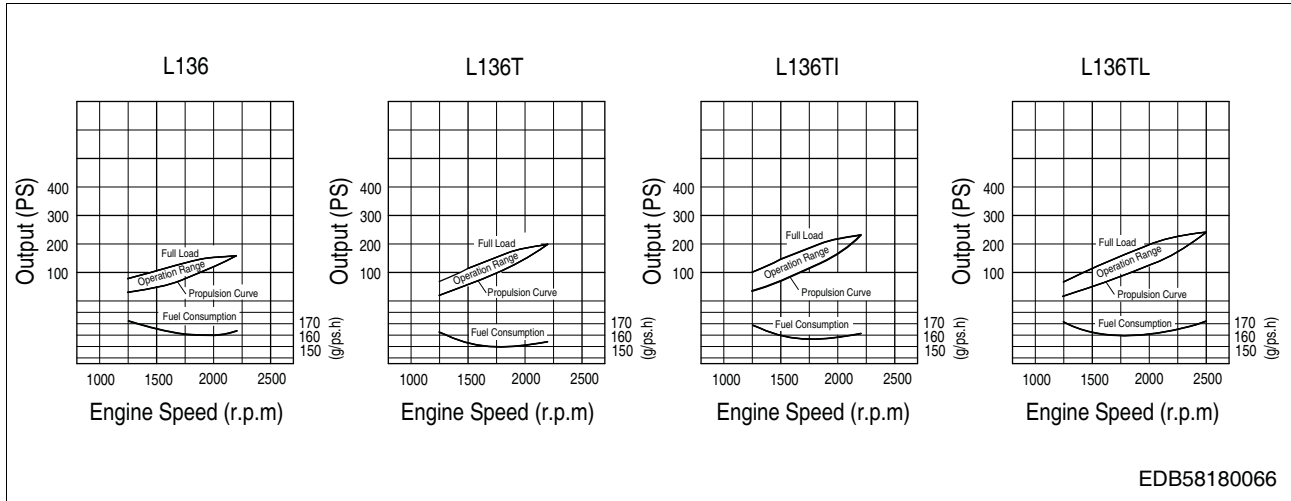

#### 1.3.2. L086TI

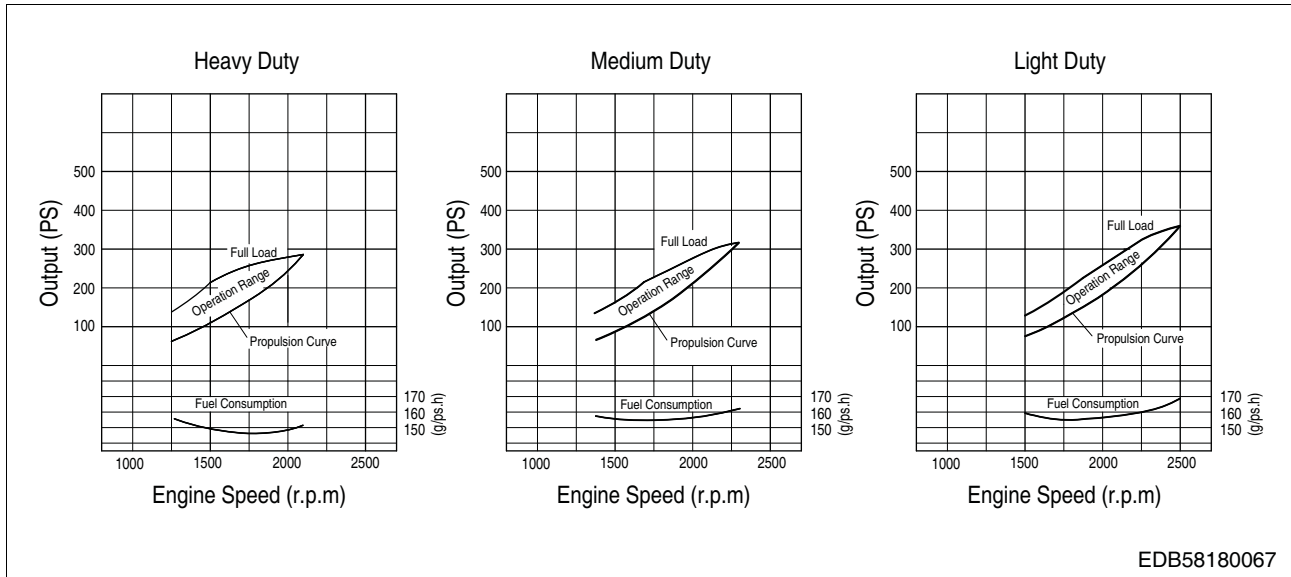

## 1.4. Engine Model & Serial Number

The engine serial number is inscribed on the engine as illustrated. This number is required when requesting warranty and ordering parts. It is also referred to as engine model and serial number because of their location.



**NOTE:** *The engine model name (L136/TI/086TI) is described in the name plate on the cylinder block.*

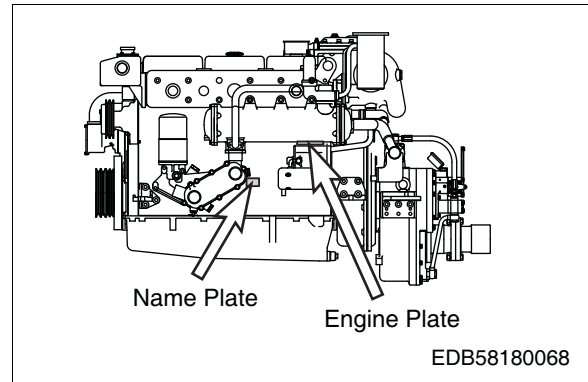

- **Engine serial No. (Example: L086TI)**

EBPKM300001

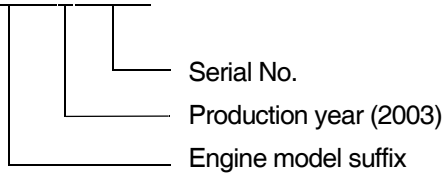

## 2. Safety Regulations

### 2.1. General Notes

Day-to-day use of power engines and the service products necessary for running them presents no problems if the persons occupied with their operation, maintenance and care are given suitable training and think as they work.

This summary is a compilation of the most important regulations. These are broken down into main sections which contain the information necessary for preventing injury to persons, damage to property and pollution. In addition to these regulations those dictated by the type of engine and its site are to be observed also.



**IMPORTANT:** *If, despite all precautions, an accident occurs, in particular through contact with caustic acids, fuel penetrating the skin, scalding from oil, antifreeze being splashed in the eyes etc, consult a doctor immediately.*

### 2.2. Regulations Designed to Prevent Accidents with Injury to Persons

#### 2.2.1. During Commissioning, Starting and Operation

Before putting the engine into operation for the first time, read the operating instructions carefully and familiarize yourself with the "critical" points, If you are unsure, ask your HD Construction Equipment representative.

- For reasons of safety we recommend you attach a notice to the door of the engine room prohibiting the access of unauthorized persons and that you draw the attention of the operating personal to the fact that they are responsible for the safety of persons who enter the engine room.
- The engine must be started and operated only by authorized personnel. Ensure that the engine cannot be started by unauthorized persons.



- When the engine is running, do not get too close to the rotating parts (All pulleys, Inj. Pump drive & propeller shafts, FPTO etc).  
Wear the close-fitting clothing as possible.





- Do not touch the engine hot parts(Exh. Manifold & turbocharger connection pipes, Inter cooler & heat exchanger connection pipes.etc) with bare hands when it is warm from operation risk of burns.
- Exhaust gases are toxic. Comply with the installation instructions for the installation of HD Construction Equipment marine diesel engines which are to be operated in enclosed spaces. Ensure that there is adequate ventilation and air extraction.
- Keep vicinity of engine, ladders and stairways free of oil and grease. Accidents caused by slipping can have serious consequences.



### 2.2.2. During Maintenance and Care

- Always carry out maintenance work when the engine is switched off. If the engine has to be maintained while it is running, e.g. changing the elements of change-over filters, remember that there is a risk of scalding. Do not get too close to rotating parts.
- Change the oil when the engine is warm from operation.



**CAUTION:** *There is a risk of burns and scalding. Do not touch oil drain plug or oil filter with bare hands.*

- Take into account the amount of oil in the sump. Use a vessel of sufficient size to ensure that the oil will not overflow.
- Open the coolant circuit only when the engine has cooled down.



**CAUTION:** *When remove the pressure of the filler cap while the engine is still hot, cover the cap with a cloth, then turn it left slowly to release internal steam pressure. This will prevent a person from scalding by hot steam spouted out.*



- Neither tighten up nor open pipes and hoses (lube oil circuit, coolant circuit and any additional hydraulic oil circuit) during the operation. The fluid which flow out can cause injury.
- Fuel is inflammable. Do not smoke or use naked lights in its vicinity. The tank must be filled only when the engine is switched off.
- When using compressed air, e.g. for cleaning the heat exchanger, wear goggles.
- Keep service products (anti-freeze) only in containers which can not be confused with drinks containers.

- Comply with the manufacturer's instructions when handling batteries.



**CAUTION:** *Accumulator acid is toxic and caustic. Battery gases are explosive.*

### 2.2.3. When Carrying Out Checking, Setting and Repair Work

- Checking, setting and repair work must be carried out by authorized personnel only.
- Use only tools which are in satisfactory condition. Slip caused by the worn open-end wrench could lead to Injury.
- When the engine is hanging on a crane, no one must be allowed to stand or pass under it. Keep lifting gear in good condition.
- When checking injectors, do not put your hands under the jet of fuel.  
Do not inhale atomized fuel.
- When working on the electrical system disconnect the battery earth cable first.  
After repair engine parts, connect it up again last in prevent short circuits.

### 2.3. Regulations Designed to Prevent Damage to Engine and Premature Wear

- (1) Never demand more of the engine than it was designed to yield for its intended purpose.  
Detailed information on this can be found in the sales literature. The injection pump must not be adjusted without prior written permission of HD Construction Equipment.
- (2) If faults occur, find the cause immediately and have it eliminated in order to prevent more serious damage.
- (3) Use only genuine HD Construction Equipment spare parts. HD Construction Equipment will accept no responsibility for damage resulting from the installation of other parts which are supposedly "just as good".
- (4) In addition to the above, note the following points.
  - Never let the engine run when dry, i.e. without lube oil, fuel or coolant. Use only HD Construction Equipment-approved service products. (engine oil, anti-freeze and anticorrosion agent)
  - Pay attention to cleanliness. The diesel fuel must be free of water. See "4.6. Fuel System".
  - Have the engine maintained at the specified intervals.
  - Do not switch off the engine immediately when it is warm, but let it run without load for about 5 minutes so that temperature equalization can take place.
  - Never put cold coolant into an overheated engine.
  - Do not add so much engine oil that the oil level rises above the max. marking on the dipstick. Do not exceed the maximum permissible tilt of the engine. Serious damage to the engine may result if these instructions are not adhered to.
  - Always ensure that the testing and monitoring equipment (for battery charge, oil pressure, and coolant temperature) function satisfactorily.
  - Do not let the sea water pump run dry. If there is a risk of frost, drain the water when the engine is switched off.



**CAUTION:** *Do not spray high-pressure water directly on the engine. It may damage engine parts, electronic parts, and wiring.*

## 2.4. Regulations Designed to Prevent Pollution

### 2.4.1. Engine Oil, Filter Element, Fuel Filter

- Take old oil only to an oil collection point. Take strict precautions to ensure that oil does not get into the drains or into the ground and sea.
- The drinking water supply may be contaminated.
- Oil and fuel filter cartridges are classed as dangerous waste and must be treated as such.

### 2.4.2. Coolant

- Treat undiluted anti-corrosion agent and / or antifreeze as dangerous waste.
- When disposing of spent coolant comply with the regulations of the relevant local authorities.

## 2.5. Notes on Safety in Handling Used Engine Oil

Prolonged or repeated contact between the skin and any kind of engine oil decreases the skin. Drying, irritation or inflammation of the skin may therefore occur. Used engine oil also contains dangerous substances which have caused skin cancer in animal experiments. If the basic rules of hygiene and health and safety at work are observed, health risks are not to the expected as a result of handling used engine oil.



### **Health precautions**

- Avoid prolonged or repeated skin contact with used engine oil.
- Protect your skin by means of suitable agents (creams etc.) or wear protective gloves.
- Clean skin which has been in contact with engine oil.
  - Wash thoroughly with soap and water. A nailbrush is an effective aid.
  - Certain products make it easier to clean your hands.
  - Do not use petrol, diesel fuel, gas oil, thinners or solvents as washing agents.
- After washing apply a fatty skin cream to the skin.
- Change oil-soaked clothing and shoes.
- Do not put oily rags into your pockets.



### **Ensure that used engine oil is disposed of properly.** **- Engine oil can endanger the water supply -**

*For this reason do not let engine oil get into the ground, waterways, the drains or the sewers. Violations are punishable. Collect and dispose of used engine oil carefully. For information on collection points please contact the seller, the supplier or the local authorities.*

## **2.6. Cause of Electrolytic Corrosion**

One of the most important causes of corrosion of metal parts in salt water is interference current from the ship's electrical system. These currents may be very weak and are often hard to detect. However, if they are active over prolonged periods of time, they may cause heavy corrosion.

Electrolytic corrosion may be prevented by a suitable electrical wiring.

Marine engine installations require special grounding of electrical system components to minimize electrolytic corrosion from stray currents and to minimize radio interference.

On metallic the boats the hull may serve as the common bonding conductor and a separate bonding system may not be required.



### 3. Commissioning and Operation

#### 3.1. Inspections Before Operation

##### 3.1.1. Lubricating Oil

- The notches in dipstick must indicate the oil level between max. and min. permissible.
- The measurement of the oil level must be done on a even water line and in 10 minutes after engine operating.
- Examining the viscosity and thecontamination of the oil smeared at the dipstick, replace the engine oil if necessary.

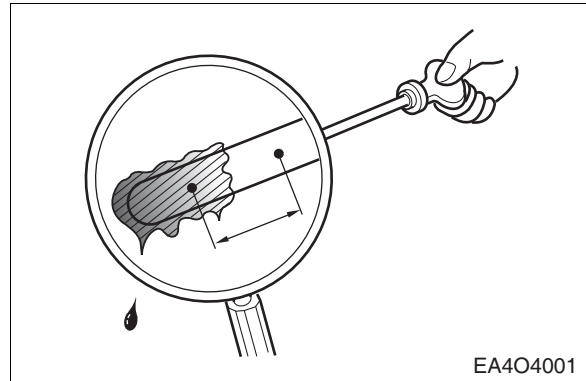

**CAUTION:** *If the installation angle of the engine exceeds 6 degrees, please remark the maximum and minimum level of the oil dipstick by engraving on the lube oil capacity of the engine. (Refer to 4.4. "Lubrication System")*

##### 3.1.2. Cooling Water

Checking the level of the cooling water in tank.

Check the opening pressure of the pressure valve using cap tester. Replace the filler cap assembly if the measured valve does not reach the specified limit.

(Opening pressure of valve: 0.5 ~ 0.9 kg/cm<sup>2</sup>)



**NOTE:** *Because it is dangerous to open the pressure cap quickly when coolant is hot, after covering the cap with a cloth and then lower the inside pressure of the tank by opening slowly at first, open it up.*

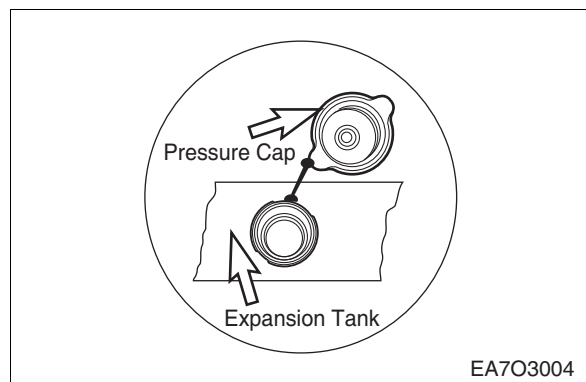

### 3.1.3. Sea Water Pump

The rotating direction of the pump impeller determines the location of the pump's intake and discharge ports.

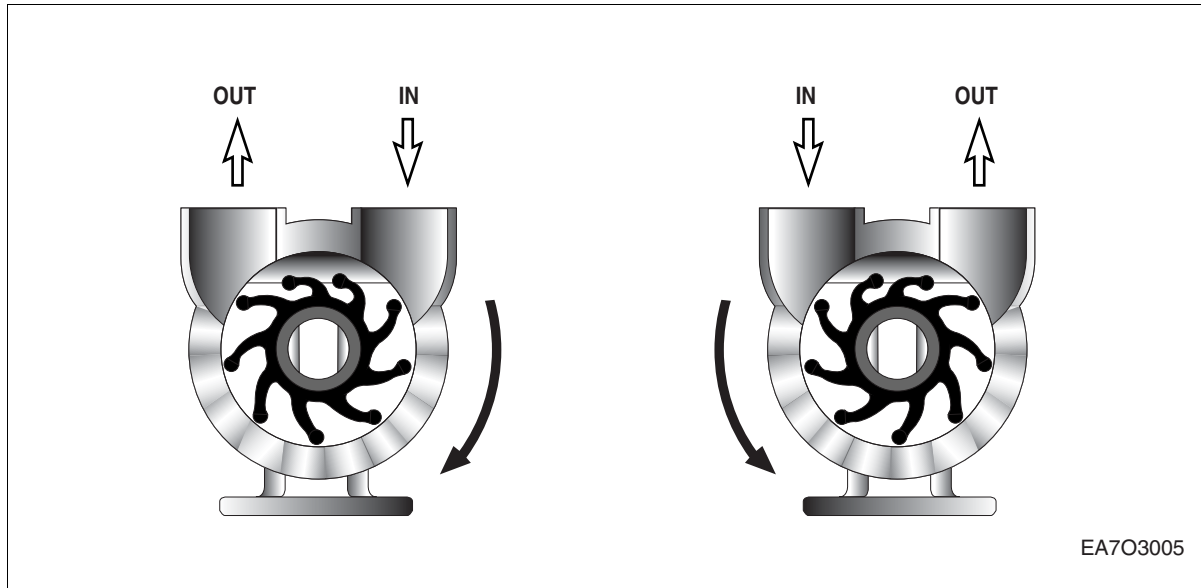

- Over-tightened belt or gear load will reduce the bearing life of the sea water pump.
- Do not run sea water pump at dry for more than 20 seconds.
- Make sure that all valves / cocks in the sea water circuit are opened before run.
- If there is a risk of freezing weather, drain the water by loosening bolts of end cover.
- Temperature range: 5°C (41°F) ~ 60°C (140°F)

### 3.1.4. Intake and Exhaust Line

Check the condition of intake and exhaust piping lines, and air filter element. If piping lines or air filter is fouled or worn, clean or replace it.

### 3.1.5. Fuel Line

Check the leaking of fuel line by opening the fuel valve.

The contamination of fuel causes the clogging of the nozzle or the sticking of the components of injection pump. Therefore the cleanness of the fuel system should be maintained at any time.

### 3.1.6. Bottom of the Engine Room

The bottom of engine room would be as clean and dry as possible.

Check the bilge to prevent water accumulation.

If water accumulation is unavoidable, do not allow the bilge water to reach the bottom of the engine.

To install a bilge pump with an automatic control switch is a good solution.



**CAUTION:** Excessive bilge water can cause engine damage like corrosion, rust and malfunction of engine parts.

### 3.1.7. Engine Stop & Warning Devices

L136/T/TI/086TI gauge panel is equipped with warning lamps and an audible alarm to alert the operator as follows.

#### 1) Engine stop device (Stop solenoid)

Engine stop solenoid is operated with warning lamps and buzzer sound at the same time as follows.

- When the engine oil pressure is less than 0.5 kg/cm<sup>2</sup>
- When the engine water temperature is more than 100°C.(212°F)

#### 2) Engine warning lamps

Engine warning lamp is turned on with buzzer sound at the same time as follows.

- When the engine oil pressure is less than 0.5 kg/cm<sup>2</sup>
- When the engine water temperature is more than 100°C.
- When the battery is not charged.

The alarm horn will sound when the ignition is turned on and continue to sound until the key switch is shifted into "OFF" position or minimum oil pressure is obtained. This provides a functional test of warning system.



*Should engine coolant overheat occurs, the alarm horn will sound and the engine is stopped by stop solenoid at the same time automatically. Proceed as follows:*

- First, quickly observe the water temperature gauge for engine coolant overheat and/or needle oscillation indicating low coolant.
- If the temperature gauge indicates engine coolant overheat range, put the control lever back to the idle speed position IMMEDIATELY and shift the reduction gear control lever into the NETURAL position. Do not restart engine until the cause for the alarm has been found and corrected. Refer to "Overheating" in "8. Trouble shooting" Chart.
- If the temperature gauge indicates high coolant temperature, check lack of coolant to fill expansion tank or thermal sensor malfunction.
- If the cause for the alarm cannot be found, contact your HD Construction Equipment dealer.

## 3.2. Starting

### 3.2.1. Operation 1 (Analog Panel)

After checking the warning lamps of the gauge panel and the NEUTRAL position of reduction gear control lever, turn the key switch to the START position to crank the engine, at once. Behavior - When the key switch is placed in the START position.

After the engine is cranked, convert the key switch to the ACC position quickly.

Behavior - As the engine is cranked, don't fix the key switch too long (over 5 seconds) in the START position. If you do so, the starter may be malfunction.

### 3.2.2. Operation 2 (Digital Panel)

Digital panel system boot, shutdown and the engine stop function.

- 1) Insert the key into key switch on the product, please rotate 90° to the right (ON) (When the key is turned "ON", keeping the key jammed)
- 2) After key on, all the system boot in 17 secs.
- 3) When turn off the system rotate the key 90° to the left (OFF)
  - When you rotate the key from the ignition state to the left (OFF) the 300 seconds alarm message pop-up on the window then engine shutdown after 300 seconds with saving event.
  - When a pop-up appears, if you rotate the key to the right (ON) pop-up disappears then the engine will remain on.

Refer to "User's Manual for Digital Panel" for details.



*If you fail the engine starting at first, restart the engine after waiting for 30 seconds at least to prevent the circuit malfunction of the starter.*

## 3.3. Engine Break-in

All HD Construction Equipment marine engines have been run for a short period of time as a final test at the factory. During the first 20 hours of operation, you must follow the **Engine Break-In** procedure to ensure maximum performance and long engine life.



**NOTE:** *Failure to follow the **Engine Break-in** procedure may result in serious engine damage and will void the engine warranty.*

During the break-in period, be particularly observe as follows:

- Check engine oil level frequently. Maintain oil level in the safe range, between the "min." and "max." marks on dipstick.
- Watch the oil pressure warning lamp. If the lamp blinks whenever the boat attitude (i.e. turning, climbing on plane, etc.) is changed, it may be the oil pick-up screen not to be covered with oil. Check oil dipstick and if required, add oil to the oil pan. But do not fill over maximum level.



**NOTE:** *Oil pressure will rise as RPM increases, and fall as the engine RPM decreases. In addition, cold oil will generally show higher oil pressure for any specific RPM than hot oil. Both of these conditions reflect normal engine operation.*

- Watch the engine water temperature gauge and be sure there is proper water circulation. The water temperature gauge needle may fluctuate if water level in expansion tank is too low.

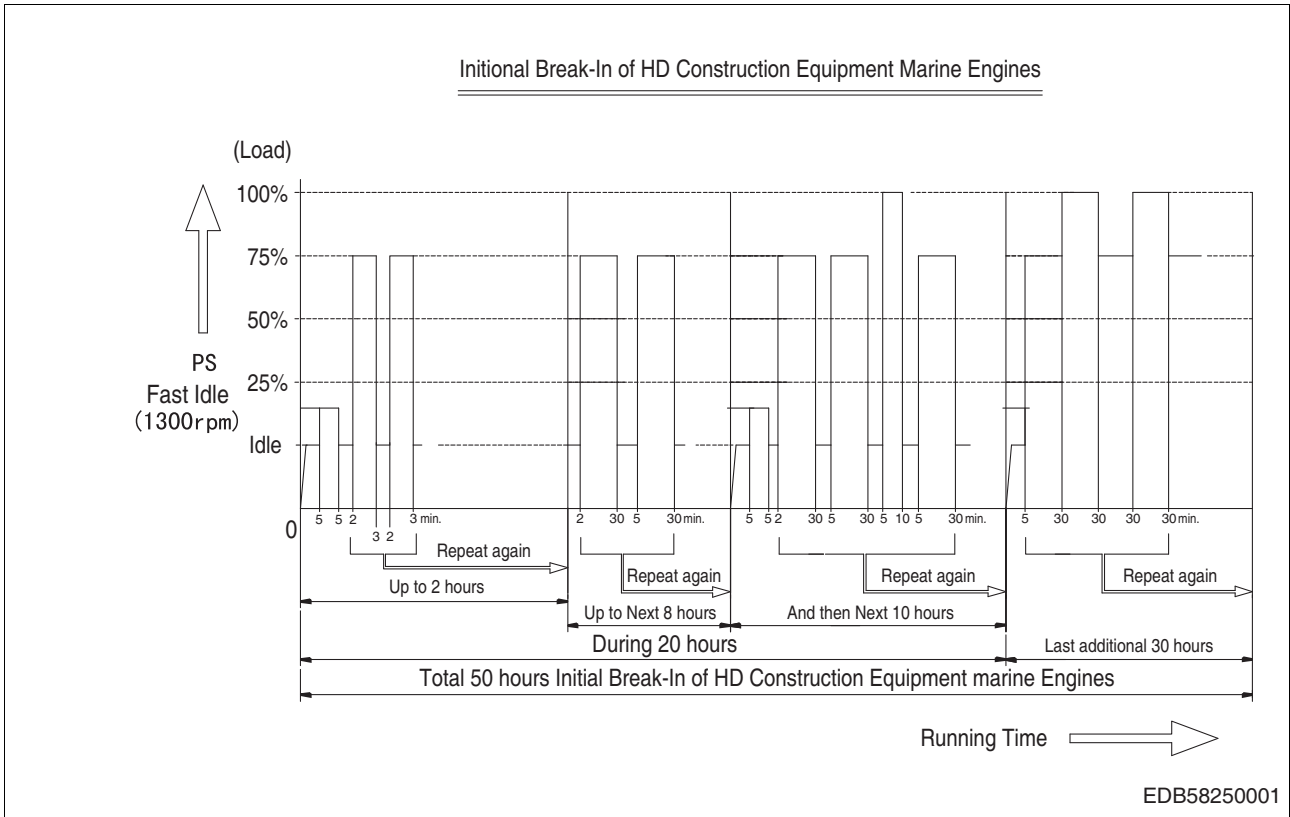

### 3.3.1. Initial Two Hours of Break-in

For the first five to ten minutes of operation, operate engine at a fast idle (below 1,500 rpm).

During the remaining first two hours of operation, accelerate to bring boat onto plane quickly and bring throttle back to maintain a planing attitude. During this period, vary the engine speed frequently by accelerating to approximately three-fourths throttle (1,700 ~ 1,800 rpm) for two to three minutes, then back to minimum planing speed (700 ~ 750 rpm).

After the engine has reached operating temperature, momentarily reduce engine speed, then increase engine speed, to assist the break-in of rings and bearings. Maintain planing boat attitude to avoid excessive engine load.



**NOTE:** Do not run engine at any constant rpm for prolonged periods of time for this initial two hours of break-in.

### 3.3.2. Next 8 Hours

During the next 8 hours, continue to operate at approximately three-fourths throttle or less (Minimum planing speed). Occasionally reduce throttle to idle speed for a cooling period. During this 8 hours of operation, it is permissible to operate at full throttle for periods of less than two minutes only 2 times.



**NOTE:** Do not run engine at a constant rpm for prolonged periods of time during the break-in period.

### 3.3.3. Final 10 Hours

During the final 10 hours of break-in, it is permissible to operate at full throttle for five to ten minutes at a time. After warming engine to operating temperature, momentarily reduce then increase engine speed. Continue to operate at approximately three-fourths throttle. Occasionally reduce engine speed to idle to provide cooling periods.



**NOTE:** *Do not run engine at a constant rpm for prolonged periods of time during the break-in period.*

### 3.3.4. Operating After Break-in 20 Hours

When starting a cold engine, always allow the engine to warm up gradually. Never run the engine at full throttle until the engine is thoroughly warmed up.

And you'd better run the engine at three-fourths throttle (about 1,800 ~ 1,900 rpm) until additional 30 hours (after finishing break-in 20 hours) as possible.

Be sure to check the oil level frequently during initial 50 hours of operation since the oil consumption will be high until the piston rings are properly seated.

When the engine operation become to reach 50 hours in total including the break-in period 20 hours, replace the engine oil and oil filter to new ones. Refer to "**4.4. Lubricating System**".



**NOTE:** *When engine is overheated, do not stop the engine immediately.  
Lower the engine load and run the engine to be a lower rpm as possible.*

### 3.4. Inspection After Starting

During operation the oil pressure in the engine lubrication system must be monitored. If the monitoring devices register a drop in the lube oil pressure, switch off the engine immediately. And the charge warning lamp of the alternator should go out when the engine is running.

- Do not disconnect the battery or pole terminals or the cables.
- If, during operation, the battery charge lamp suddenly lights up, stop the engine immediately and remedy the fault in the electrical system.
- Engine should be stopped if the color, the noise or the odor of exhaust gas is not normal.
- Confirm the following things through warning lamps and gauge panel.

#### 3.4.1. Pressure of Lubricating Oil

The normal pressure comes up to 1 kg/cm<sup>2</sup> (1.0 bar) at idling and 3 ~ 5 kg/cm<sup>2</sup> (3.0 ~ 4.9 bar) at rated speed. If the pressure fluctuates at idling or does not reach up to the expected level at high speed, shut down the engine immediately and check the oil level and the oil line leakage.

#### 3.4.2. Temperature of Cooling Water

The cooling water temperature should be 71 ~ 85°C in normal operating conditions. Abnormally high cooling water temperature could cause the overheating of engine and the sticking of cylinder components. And excessively low cooling water temperature increases the fuel consumption, accelerates the wears of cylinder liners and shortens the engine life-time.

### 3.5. Check After Initial 50 Hours Operation

To insure your continued boating enjoyment, you should check as follows:

- Change engine oil and oil filter cartridge.
- Change fuel filter cartridge.
- Check coolant level.
- Check the tension of all drive belts.
- Check engine mounting screws for tightness.
- Check for any deficiencies, malfunctions, signs of abuse, etc. Correction of any problems at this time will prevent the worsening of a minor problem and help ensure a trouble free boating season.



**NOTE:** *This time is a good opportune to discuss with your dealer about your engine etc which may have arisen after the first 50 hours of operation and establish a routine preventive maintenance schedule like "4.2. Periodical Inspection & Maintenance".*

### **3.6. Operation in Winter Time**

Pay special attention to the freezing of cooling water and the viscosity of lubricating oil.

#### **3.6.1. Prevention Against the Freeze of Cooling Water**

When not using anti-freeze, completely discharge the whole cooling water after engine running. The freeze of cooling water causes the fatal damages of the engine. Because the anti-freeze is used to prevent coolant from freeze and corrosion, it is always to be filled with the anti-freeze 35 ~ 40% of the engine whole coolant.

#### **3.6.2. Prevention Against Excessive Cooling**

Drop of thermal efficiency caused by excessive cooling increases fuel consumption. Therefore prevent the engine from excessive cooling. If the temperature of coolant does not reach to normal condition (71 ~ 85°C) after continuous operation, examine the thermostat or the other cooling lines.

#### **3.6.3. Lubricating Oil**

As cold weather leads to the rise of oil viscosity, engine speed becomes unstable after starting. Therefore the lubricating oil for winter (API CI-4, SAE 10W40) should be used to prevent this unstableness. Refer to "4.4. Lubricating System".

### **3.7. Tuning the Engine**

The purpose of an engine tune-up is to restore power and performance that's been lost through wear, corrosion or deterioration of one or more parts or components. In the normal operation of an engine, these changes can take place gradually at a number of points, so that it's seldom advisable to attempt an improvement in performance by correction of one or two items only.

Time will be saved and more lasting results will be obtained by following definition and thorough procedure of analysis and correction of all items affecting power and performance.

Economical, trouble-free operation can better be ensured if a complete tune-up is performed once every year, preferably in spring. Components that affect power and performance to be checked are:

- Components affecting fuel injection:  
Nozzle, delivery valve, fuel filter, fuel water separator, etc.
- Components affecting intake & exhaust:  
Air filter, inter-cooler, turbo-charger, silencer, good ventilation of engine room, etc.
- Components affecting lubrication & cooling:  
Air & oil filter, anti- freeze, heat exchanger, rubber impeller, sea water filter, kingston valve, misalignment of propeller, stableness of bed frame, bent propeller blade, etc.

## **4. Maintenance and Care**

### **4.1. General Instructions**

- (1) Before performing service operation, disconnect the grounding cable from the battery for reducing the chance of cable damage and burning due to short-circuiting.
- (2) Use covers to prevent the disassembled parts and components from damage or pollution.
- (3) Engine oil and anti-freeze solution must be handled with care. They can cause damage for painted parts.
- (4) The use of proper tools or specified special tools is important to perform the efficient and reliable maintenance operation.
- (5) Use genuine HD Construction Equipment parts necessarily.
- (6) Used cotter pins, gaskets, O-rings, oil seals, lock washer, self-lock nuts and rubber coated seal ring etc. should be discarded. New ones should be used for re-assembled parts.  
If these are reused, normal performance can not be maintained.
- (7) To facilitate reassembling, keep disassembled parts neatly in groups. Fixing bolts and nuts for reassembled parts should be reused at the original position. They are varied in hardness or length because they are designed depending on their application.
- (8) Clean the disassembled parts prior to inspection or re-assembly. By using compressed air, make oil ports and etc. of them free from any foreign material.
- (9) Lubricate the surface of rotating and sliding parts with oil or grease before installation.
- (10) If necessary, use sealant onto gaskets to prevent leakage.
- (11) Carefully obey all specified torque to tighten bolts and nuts
- (12) When maintenance is completed, make a final check to be sure it has been done properly.

## 4.2. Periodical Inspection & Maintenance

In order to insure maximum, trouble-free engine performance at all times, regular inspection, adjustment and maintenance are vital before occurring any problems.

- Daily inspections in below figure should be checked every day.
- The following maintenance details should be executed thoroughly at regular intervals.

Inspection		Daily	Every 50 hrs	Every 100 hrs	Every 250 hrs	Every 500 hrs	Every 600 hrs	Every 1,000 hrs
Cooling system	Coolant level check and refill	●						
	Contamination of the coolant check and the quantity of the anti-freeze						●	1 year change
	Heat-exchanger and water cooling line cleaning (Change O-ring & Gasket)							1,200 hr
	V-belt check and adjustment	●						2,000 hrs change
	Check thermostat and clean or exchange for excessive corrosion							1 years
	Impeller of sea water pump check	●						2,000 hr change
Lubrication system	Oil level check	●						
	Lubrication oil exchange		● 1st		●			
	Oil filter cartridge replacement		● 1st		●			
	Marine gear oil exchange			● 1st			●	
Intake exhaust fuel system	Air filter element cleaning & change			● Clean			● Change	
	Inter-cooler cleaning							●
	Turbocharger cleaning							2,000 hrs
	Exhaust gas check	●						
	Priming pump strainer cleaning				●			
	Fuel tank check & cleaning		●					
	Water separator cleaning			●				
	Fuel filter exchange		● 1st			●		
	Fuel Injection timing check							1 year
	Fuel Injection nozzle check							1 year
Electrical system	Warning lamps check	●						
	Battery charging check	●						
	Wiring harness check						●	
Cylinder	Cylinder compression pressure check							● needed
	In./ Ex. valve clearance adjustment							●

\* If the sulfur content of the fuel is more than 0.5%, the replacement and inspection cycle should be cut in half.

## 4.3. Cooling System

### 4.3.1. Coolant Level Check and Refill

- Replenish the deficient coolant in the expansion tank every day before running. The coolant must be changed at intervals of 1,200 hours operation or six months whichever comes first. If the coolant is being fouled greatly, it will lead engine overheat or coolant blow off from the expansion tank.
- Clean fresh water should be used for engine coolant.
- Additional agent (35 ~ 40% anti-freeze and 3 ~ 5% anti-corrosion agent) should be mixed with fresh water for engine coolant to prevent the cooling system problem like freezing, corrosion and etc.



**CAUTION:** Suitable mixture of anti-freeze and anti-corrosion agent can protect the engine corrosion from deteriorating and raises a boiling point, but by using unsuitable mixture engine components like water pump impeller and water jacket of cylinder block may be occurred a malfunction by any bad corrosion damage or cavitation.

#### 1) Coolant replenishment

Let the plug in the highest level of the water lines or the upper plug of wet turbocharger open, and fill the coolant about three fourth of the expansion tank slowly until the air bubbles in water do not come out through the plug hole. Then reassemble the plug. After filling the coolant, run the engine at the idle rpm for around 5 minutes and you will find out the engine coolant level becomes lower than before cause of escaping the air bubbles in water. Then stop the engine and replenish additional coolant properly.

#### 2) Coolant change

- Open the pressure cap of expansion to remove the air pressure.
- Loosen two drain plugs. One is lower side of the oil cooler and another is upper side of the starter as figure.
- After drain reassemble the plug and replenish the coolant as same as "(1) Coolant replenishment".

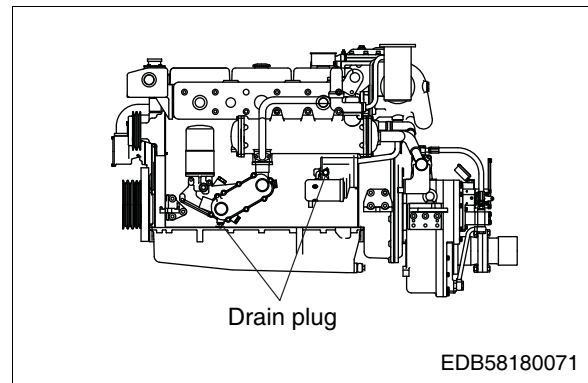

**CAUTION:** When remove the pressure of the filler cap while the engine is still hot, cover the cap with a cloth, then turn it left slowly to release internal steam pressure. This will prevent a person from scalding by hot steam spouted out from the filler cap.

#### 4.3.2. Contamination Check of the Coolant and the Quantity of the Anti-freeze

We recommend the engine coolant for HD Construction Equipment marine engines should be mixture of fresh water and additional agent (35 ~ 40% anti-freeze and 3 ~ 5% anti-corrosion agent).

Check the quantity of the anti-freeze every 600 hours. From time to time, refill the anti-freeze as much as required.

You can check the quantity of anti-freeze and anti-corrosion agent by using a FLEETGUARD test kit simply as follow. (Fleetguard CC2602M: DHI No.; 60.99901-0038)

##### 1) Contamination check

- **How to use test kit (Striped pad)**

- (1) Collect half of a coolant sample cup from a drain plug at the lower side of the oil cooler or cylinder block. Coolant must be between 10°C and 55°C when tested. Room temperature is preferred.



**Do not collect the coolant from the expansion tank or overflow system.**

*The collected sample is less contaminated, so it can not be substituted for the quality of whole coolant.*

- (2) Shake the bottle filled with sample coolant to mix well and take out one strip from bottle of the test kit. Then dip the strip in coolant sample for 3 ~ 5 seconds, take it out and shake it briskly to remove excess liquid.



**Do not touch the pads on the end of the strip. Discard the kit if unused strips have turned brown for the nitrite test pad.**

- (3) Wait for 45 seconds after taking the strip out in the bottle of the sample coolant, then compare the color of the pads with the standard color chart of the test kit label and record the result as follows.



**CAUTION:** All three pad readings must be completed **no later than 75 seconds** after dipping strip.

*Do not touch the stripe with fingers.*

- **How to judge the strip**

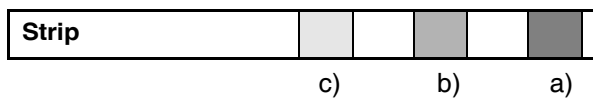

- a) Compare FREEZEPOINT (end pad) to chart and record result.
- b) Next compare MOLYDATE (middle pad) to chart and record result.
- c) Finally compare NITRITE test to chart and record result.

- (1) Compare the end pad "a)" color of the strip with color blocks of a row at the upper part of the standard color chart (below of the letter "GLYCOL/FREEZE POINT"). Same color in the block of the row means the content of anti-freeze in the coolant.  
(Normal range is between 33% and 50%.)
- (2) Compare the middle pad "b)" color of the strip with the color that the column block color of MOLYDATE at the left side of the table intersects the row block color of NITRITE at the bottom (pad "c)" color of the strip) on the table "SCA Units per Litre". (Normal range of "SCA Units per Litre" is between 0.3 and 0.8: "green color area")

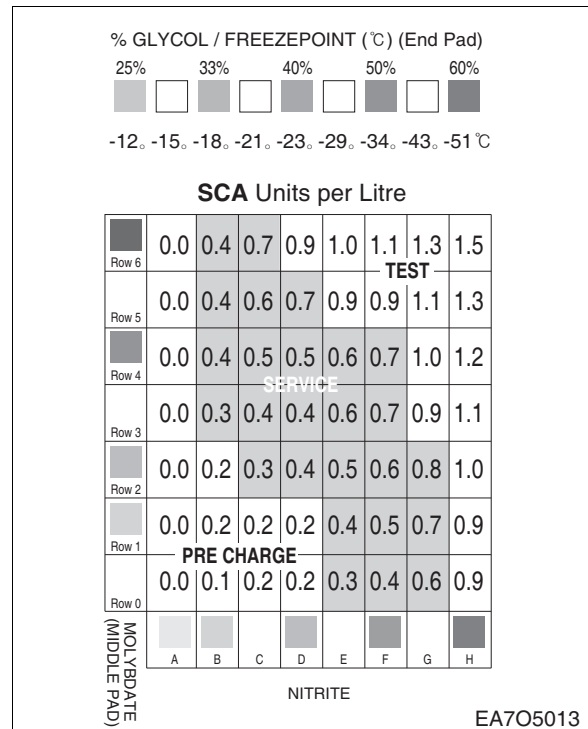

*During the comparison, if uncertain about color match, pick the lower numbered block. (example: if the color of NITRITE pad is between standard color "D" and "F", then use column E.)*

- (3) If the value of "SCA Units per Litre" is less than 0.3, refill the DCA4 liquid (anti-corrosion agent) a little, But larger than 0.8, Drain some amount of engine coolant and replenish the fresh water instead. The content of the anti-freeze and anti-corrosion agent can be regulated by this way.



***Every year coolant must be replaced. It is essential the coolant should be mixture of fresh water, proper anti-freeze and anti-corrosion agent.***

2) Quantity of anti-freeze

The anti-freeze, 35 ~ 40% of the whole coolant, is always to be used to prevent the cooling system from the corrosion. And in winter the amount of anti-freeze shown in the following table should be used in accordance with the ambient temperature.

As the individual freezing points corresponding to the proportions of antifreeze in the table are subject to change slightly according to the kind of antifreeze, you must follow the specifications provided by the antifreeze manufacturer.

Ambient Temperature (°C)	Cooling Water (%)	Anti-freeze (%)
Over -10	85	15
-10	80	20
-15	73	27
-20	67	33
-25	60	40
-30	56	44
-40	50	50

Any coolant loss due to engine operation must be replenished. But adding fresh water for coolant tends to lower the content of anti-freeze. Always replenish the coolant with a mixture of anti-freeze and water, and keep the proper content of antifreeze (35 ~ 40%)

#### 4.3.3. Heat Exchanger and Water Cooling Line Cleaning

1) Heat exchanger cleaning

If the heat exchanger tubes are clogged by small pieces or polluted by corrosion, the volume of supplied sea water will be reduced gradually. This would be cause of engine overheating.

- Disassemble both left and right side covers of the heat exchanger.
- Remove the clogged small pieces and clean the heat-exchanger tubes.  
When the heat-exchanger tubes do cleaning, clean outside and inner side of tubes by using a small wire brush and pressurized water.

2) Fresh water cooling line cleaning

If the cooling circuits are fouled with water scales or sludge particles, the cooling efficiency will be lowered.

The poor condition of the cooling system might be normally due to use of unsuitable antifreezing agents so periodically clean the circuit interior with a cleaner.



**Cooling system cleaning interval: Every 1,200 hours**

#### 4.3.4. V-belt Check and Adjustment

##### 1) Visual check

Check the belt for cracks, oil, overheating and wear.

##### 2) Tension check

By the finger-pressure, the belt is pressed by 10 ~ 15 mm between the water pump pulley and the alternator pulley in normal condition.

For the adjustment of the tension, loosen the adjusting bolts which support the alternator, adjust the tension and tighten the bolts again.

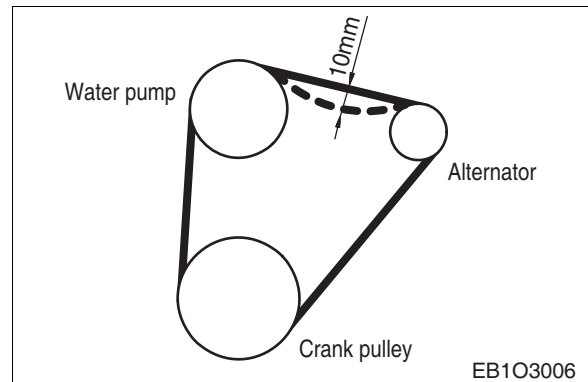

##### 3) V-belt change

Change the belt if necessary after every 2,000 hours of operation.

If, in the case of a multiple belt drive, wear or differing tensions are found, always replace the complete set of the belts.



**NOTE:** Always apply to HD Construction Equipment genuine parts every replacement.

#### 4.3.5. Thermostat Check

The thermostat maintains a constant temperature of coolant (71 ~ 85°C) and improves thermal efficiency of the engine by preventing heat loss.

Namely, when the temperature of coolant is lower than 85°C, the thermostat valve is closed to make the coolant bypass to directly enter the water pump. When the coolant temperature rises to open wide the thermostat valve, the bypass circuit is closed and the water passage to the heat exchanger is opened so that the coolant is forced to flow into the heat exchanger.

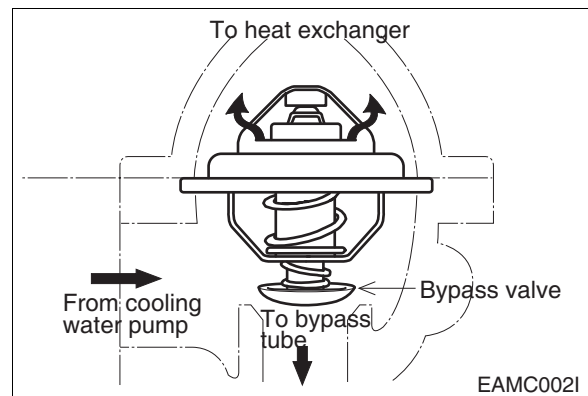

Item	Specifications
Type	Wax-pallet type
Open at	71°C
Open wide at	85°C
Valve lift	8 mm or more

- **Inspection**

- (1) Check the wax pallet and spring for damage.
- (2) Put the thermostat in a container of water, then heat the water slowly and check temperature with a thermometer. If the valve lift is 0.1 mm (starting to open) at temperature of 71°C and 8 mm or more (opening wide) at temperature of 85°C, the thermostat is normal.

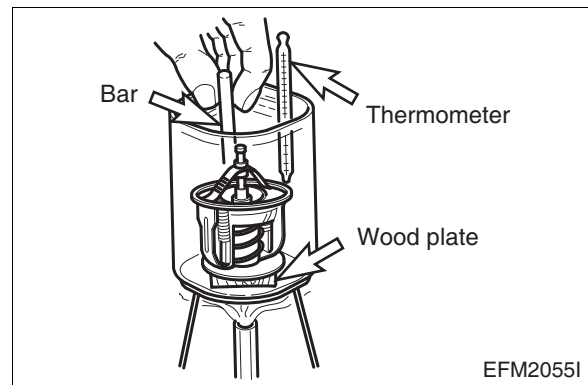

- **Thermostat replacement**

- (1) Precautions for handling

The wax pallet type thermostat does not react as quickly as bellows type one to a variation of temperature of coolant. Such relatively slow reaction is mainly due to the large heat capacity of the wax pellet type thermostat. Therefore, to avoid a sharp rise of coolant temperature, it is essential to idle the engine sufficiently before running it. In cold weather, do not run the engine at overload or overspeed it immediately after starting off.

- (2) When draining out or replenishing coolant, do it slowly so that air is bled sufficiently from the entire cooling system.

- (3) Replacing thermostat.

If the thermostat is detected defective, replace with a new one.

Check the thermostat and clean or exchange for excessive corrosion every 1 year.

#### **4.3.6. Impeller of Sea Water Pump Check**

The sea water pump is a rubber impeller type driven by gear. Every time the engine starts you should always check whether the kingston valve on the bottom of boat is opened or not. If the engine is run in a dry impeller condition for more than 20 seconds, the rubber impeller is burned and cracked by high revolution of sea water pump.

- **Impeller disassembly**

- (1) Remove end cover screws, end cover and o-ring.
- (2) Grasp the hub of impeller with water pump pliers and withdraw it by twisting to the rotating direction of the sea water pump body or remove it using two drivers like upper figure.
- (3) Detach the cam unscrewed a bolt and clean the sealant of cam and body bore.
- (4) Remove the wear-plate.

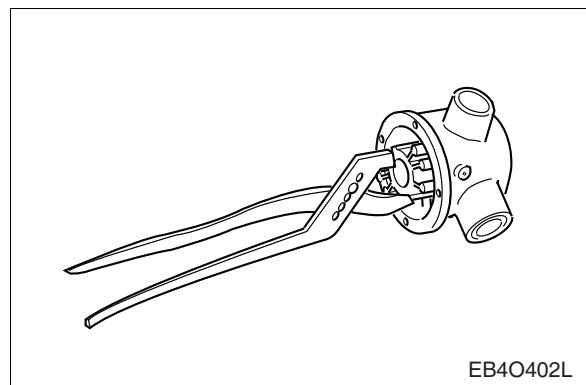
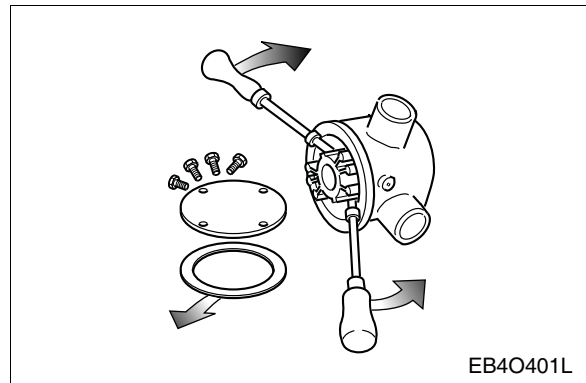

- **Impeller assembly**

- (1) Install wear-plate in body bore, aligning slot in wear-plate with dowel pin in body.
- (2) Apply a thin coat of sealant to cam screw threads and top side of cam and install in body with cam screw.
- (3) Lubricate impeller bore and end surfaces of impeller with light coat of water pump grease and start the impeller in bore with a rotary motion until shaft key engage, then push it into the bore side by twisting into rotating direction.

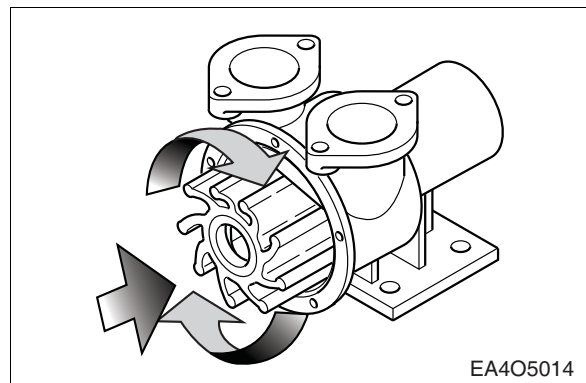

**CAUTION:** *When you assemble the rubber impeller, do not use hammer to prevent the mechanical damage.*

- (4) Install O-ring and end cover and secure with end cover screws.
- (5) After assembled the impeller open the kingston valve and check the leakage of sea water pump on running the engine.

## 4.4. Lubrication System

### 4.4.1. Oil Level Check

- The notches in dipstick must indicate the oil level between high and low permissible when the vessel is in the water and with its normal trim.
- The oil level should be checked with the engine horizontal and only after it has been shut down for about 10 minutes.
- Examining the viscosity and the contamination of the oil smeared at the dipstick, replace the engine oil if necessary.

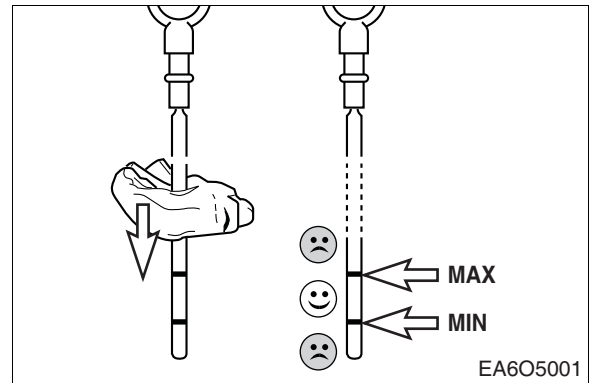

**CAUTION:** Do not add so much engine oil that the oil level rises above the maximum marking on the dipstick. Over filling causes excessive blow-by gas and will result in damage to the engine.

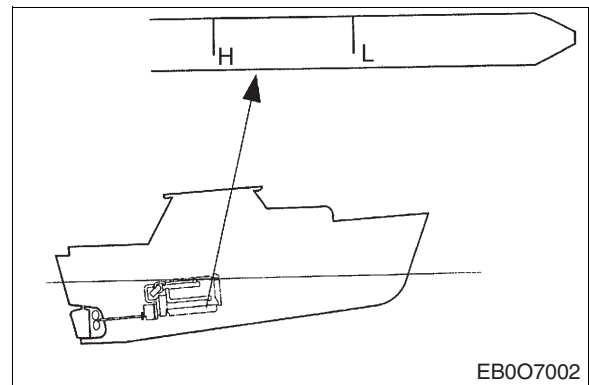

- **How to re-mark the oil dipstick**

Since the inclination angle of marine engine may vary greatly as vessels, the high and low oil levels on the dipstick should be also changed when the engine inclination angle is over 6 degree.

Dipstick should be re-marked by engraving on the lube oil capacity of each engine. Be sure to check and mark the oil levels between High and Low when the vessel is commissioning at first.

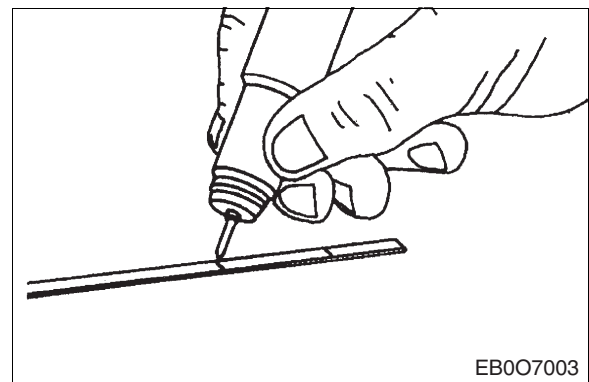

Please note that stamping or notching will weaken the dipstick and the tip of the dipstick may break off in the oil pan.

The capacity of lube oil can be referred to "**1.1. Engine Specification**".

#### 4.4.2. Lubrication Oil Exchange

Engine oil and the oil filter are important factors affecting engine life. They affect ease of starting, fuel economy, combustion chamber deposits and engine wear.

The first engine oil change should be after 50 hours of operation and next exchange will be performed every 250 hours. At the end of the break-in period (50 hours), change the engine oil and replace the oil filter cartridge to new one.

##### 1) Oil drainage

- While the oil is still hot, discharge the sump oil or marine gear sump oil by rotating oil drain pump manually.

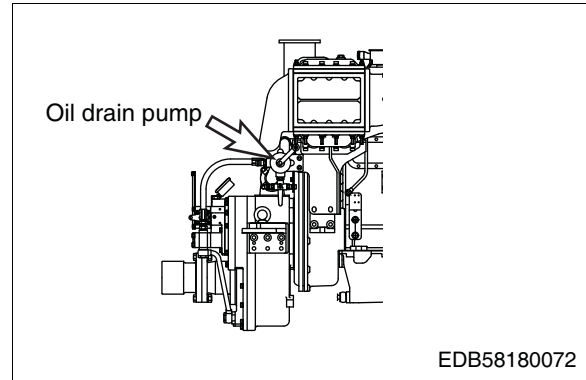

- Refill new engine oil to the oil filler neck on the head cover in accordance with the oil capacity of the engine. Be careful about the mixing of dust or contaminator during the supplement of the engine oil. Then confirm that the oil level gauge indicates the vicinity of its maximum level.

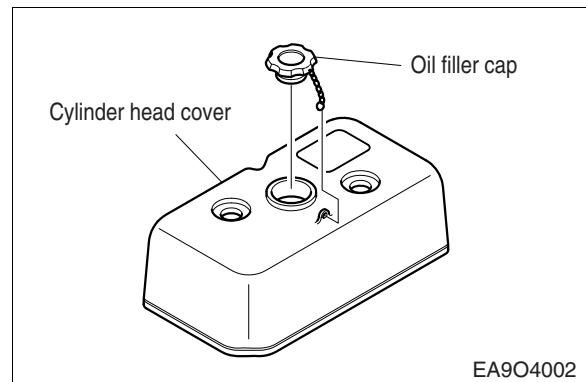

- For a few minutes, operate the engine at idling in order to circulate oil through lubrication system.

- Thereafter shut down the engine. After waiting for about 10 minutes, measure the quantity of oil and refill the additional oil if necessary.



##### • Recommendation for lubrication oil

Initial factory filling is high quality break-in oil (API service CI-4 grade). During the break-in period (50 hours), check the oil level frequently. Somewhat higher oil consumption is normal until piston rings are seated. The oil level should be maintained in the safe range between the Min. and Max. mark on the dipstick. To obtain the best engine performance and engine life, engine oil is specified by API service, letter designations and SAE viscosity numbers. If the specified engine oil is not available, use a reputable brand of engine oil labeled for API service CI-4 and SAE viscosity 10W40.

Refer to oil identification symbol on the container.

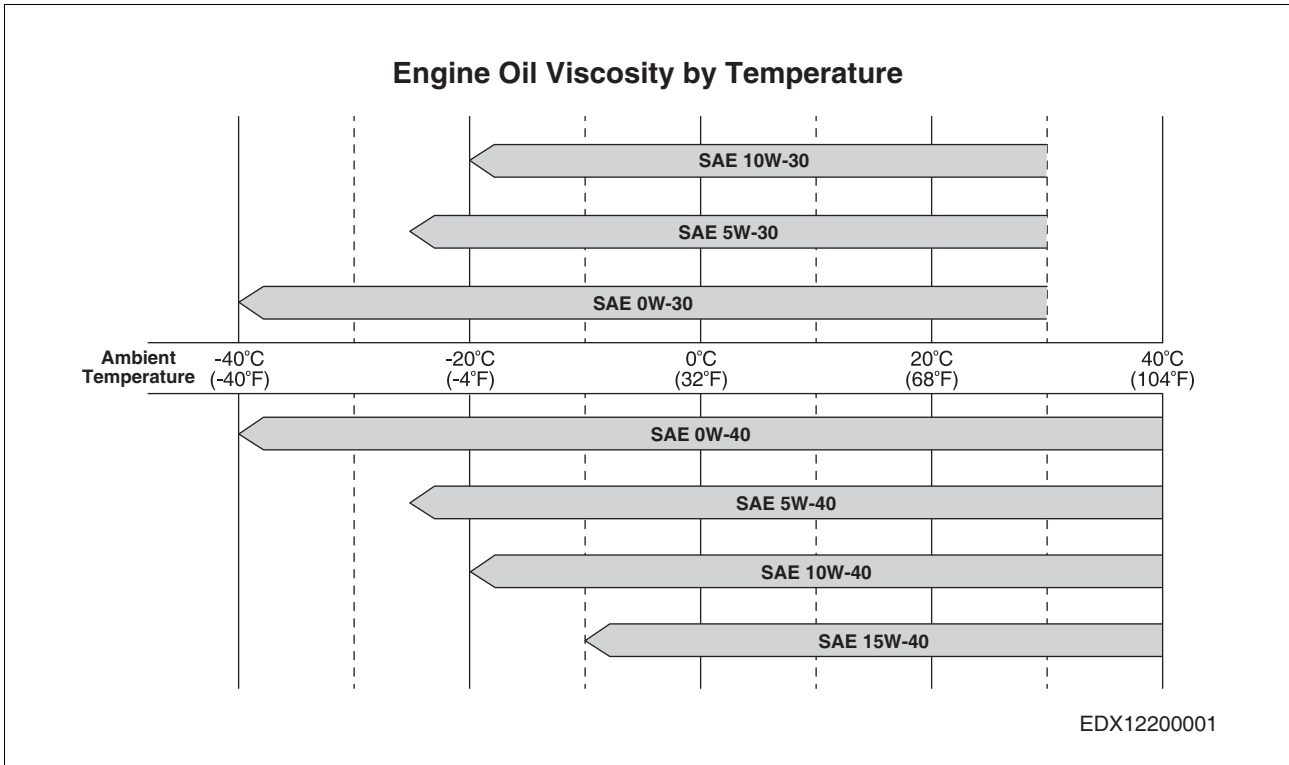

\* Recommended oil: DIC Diesel Engine oil 10W40 (API CI-4 grade, SAE 10W40)

#### 4.4.3. Oil Filter Cartridge Replacement

Every time oil exchanges, replace the oil filter cartridge.

- Drain engine oil by loosening the drain plug on the filter head.



**CAUTION:** Don't forget tightening the drain plug after having drained engine oil.

- Remove the oil filter by turning it counter-clockwise with a filter wrench.
- Wipe, clean the fitting face of the body contacting with the oil filter so that new oil filter cartridge can be seated properly.
- Lightly oil the O-ring and turn the oil filter until sealing face is fitted against the O-ring. And then turn it in addition by 3/4 ~ 1 turns further with hand or the filter wrench.

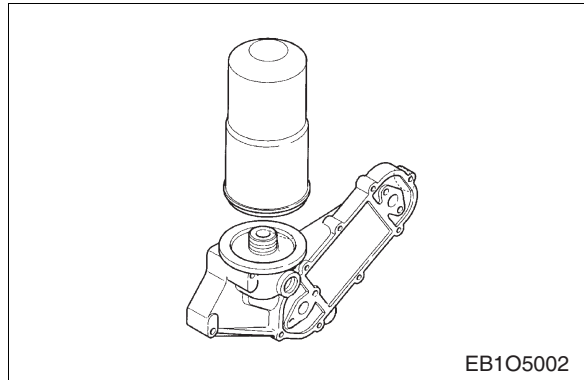

**NOTE:** It is strongly advisable to use HD Construction Equipment genuine oil filter cartridge for replacement.

#### 4.4.4. Marine Gear Oil Change

Always apply to API service SAE #30 for reduction gear oil change the reduction gear oil at 100 hours of operation at first and next exchange will be performed every 600 hours.

#### 4.4.5. Cylinder Compression Pressure Check

- Stop the engine after warming up, and take out nozzle holder assembly.
- Install the special tool (compression gauge adapter) at the nozzle holder hole, and connect the compression pressure gauge there.

Standard value	28 kg/cm <sup>2</sup>
----------------	-----------------------

\* Test Condition

Cooling water temperature 20°C,  
Engine rotation 200 rpm (about  
10 revolutions)

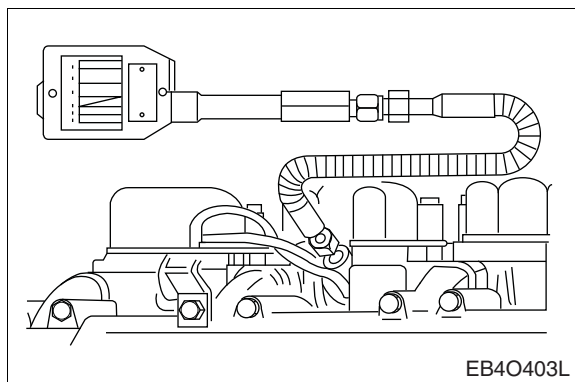

### 4.5. Intake & Exhaust System

#### 4.5.1. Valve Clearance Adjustment

Usually should check the valve clearance of intake & exhaust every 1,000 hours after engine operation. Refer to "**6.3.24. Valve Clearance Adjustment**" details.



The valve clearances are to be adjusted at the times of the following situations.

- After initial 50 hours operation.
- When the engine is overhauled and the cylinder heads are disassembled.
- When severe noise comes from valve train.
- When the engine is not normally operated, even though there is no trouble in the fuel system.

#### 4.5.2. Air Filter Element Cleaning & Change

The engine life and performance depends on the intake air condition greatly.

A fouled air filter element results decreased intake air amount that leads decreased engine output and finally may cause an engine malfunction.

Further, a damaged air filter element results wear on the cylinder component or the valve mechanism etc. leading increased engine oil consumption and decreased engine output, finally leads to shorten the engine life.

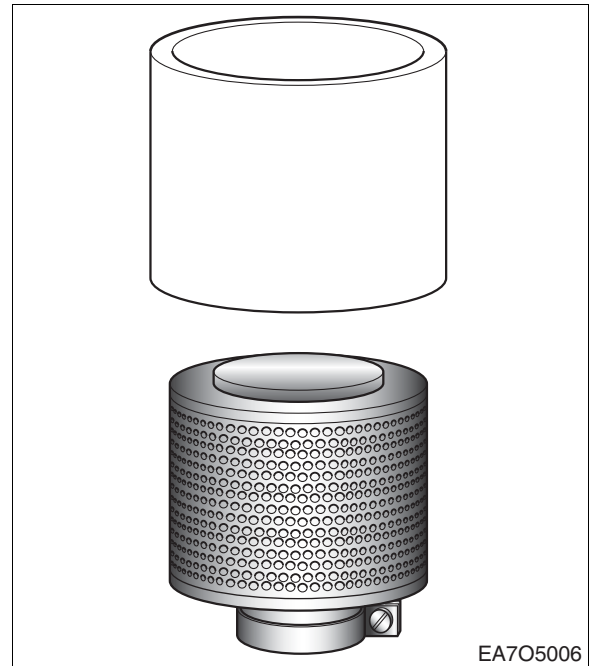

The air filter element should be cleaned periodically as follow.

- **Cleaning of the air filter element: Every 100 hours**
- **Exchange of the air filter element: Every 400 hours**  
**Replace the air cleaner if deformed, broken or cracked.**

##### 1) Air filter element cleaning

- Wash the polluted element in warm water non-household detergent.
- Rinse the element with clean water
- Dry it thoroughly with natural air or electric fan.  
Don't use a flame or compressed air for dry.  
It makes damages to the element.

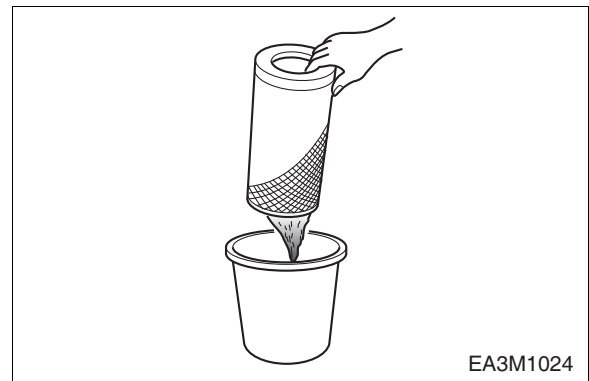

##### 2) Air filter element check

- Confirm inside of the element clean and dry.
- Replace the new element if tears, rips or damages are found.

### 4.5.3. Inter-cooler Cleaning

Inter-cooler depends on the intake air condition greatly. The fouled air pollutes and clogs the air fins of the inter cooler.

As a result of this, the engine output is decreased and the engine malfunction may be occurred. Therefore always check whether the intake air systems like air filter element are worn or polluted.

The inter-cooler has to be removed from the engine for cleaning.

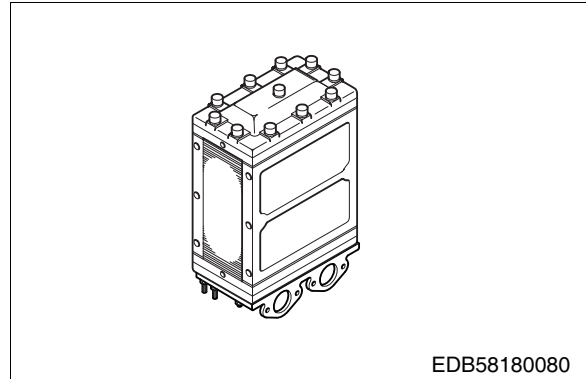

- **How to inter-cooler cleaning**

In order to maintain the heat transfer efficiency of the inter-cooler, it is necessary to clean it at regular intervals. For this purpose, dismantle the inter-cooler. In almost all cases, it will suffice to clean the individual parts in a hot alkaline solution, e.g. a 3 to 5% P3-FD solution. If hard and firmly adhering scale deposits continue to exist, a second treatment should be made with a descaling agent which will not corrode the cooler core. Use new gaskets when reassembling the inter-cooler.

Be sure to clean the sealing surfaces carefully before installing the gaskets.

Observe the specified pressure when making the hydraulic test.

<b>Test Gauge Pressure</b>	water side	400 kPa (4 bar)
	charge air side	300 kPa (3 bar)



***Cleaning of inter cooler: Every 1,000 hours.***

### 4.5.4. Turbocharger Cleaning

- Turbocharger should be cleaned every 2,000 hours. The only points to be observed are the oil pipes which should be checked at every oil change for leakage and restrictions. Inspect the condition of turbocharger like oil leaks, and unusual turbo sounds periodically.
- Air cleaner element should be checked and cleaned periodically to prevent foreign matters from entering the inside of the engine.
- Should check and measure the pressure of intake air and exhaust gas periodically. If there is air leakage, should repair the problem at once not to occur the engine power loss and over heating.
- In case of operating in highly dust or oil-laden atmospheres, cleaning of the air compressor impeller may be necessary from time to time. To this end, remove compressor casing (**Caution: Do not skew it!**) and clean in a non-acid solvent, if necessary use a plastic scraper. If the air compressor should be badly fouled, it is recommended that the wheel be allowed to soak in a vessel with solvent and to clean it then with a stiff non-steel brush. In doing so, take care to see that only the compressor wheel is immersed and that the turbocharger is supported on the bearing casing and not on the wheel.

#### 4.5.5. Exhaust Gas Check

Exhaust gas depends on much or less of it shows whether combustion condition of the engine is good or not. If exhaust gas is any abnormal condition like excessive smoke, white smoke, black smoke, the engine should be serviced maintenance from specialist.

#### 4.6. Fuel System

As fuel injection pumps and injection nozzles consist of very complicated and precise components, the contamination of fuel causes the clogging of the nozzle or the sticking of the injection pump components. Therefore, the cleanness of the fuel system should be maintained at any time.

If the engine is equipped with a fuel water separator, drain off any water that has accumulated.

Water in fuel can seriously affect engine performance and may cause engine damage.

##### 4.6.1. Priming Pump Strainer Cleaning

Clean the priming pump strainer every 100 hours operation. The strainer is incorporated in the priming pump inlet side joint bolt. Clean the strainer with the compressed air and rinse it in the fuel oil.

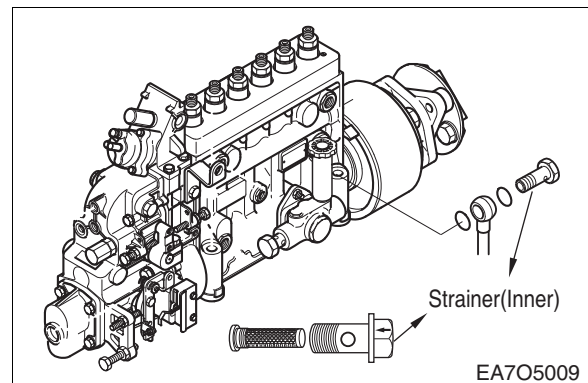

##### 4.6.2. Fuel Tank Check & Cleaning

Fill the tank with recommended fuel and should reduce water condensation of the fuel tank as possible. Also it is important for the engine performance to keep the fuel cool.



***Make sure fuel supply valves (if used) are opened before run.***

In marine environment, the most likely fuel contaminants are water and microbial growth (black "slime"). Generally, this type of contamination is the result of poor fuel handling practices.

Black "slime" requires water in the fuel to form and grow, so the best prevention is to keep water condensation to a minimum in storage tanks.

If diesel fuel which contains moisture is used, injection system and cylinder liners, pistons will be damaged. Drain moisture and accumulated sediment from drainage device of storage tank regularly. You'd better change the element of the water separator or fuel filter cartridge several times until fuel of the suction line is cleaned.



***NOTICE:*** *A galvanized steel tank should never be used for fuel storage, because fuel oil reacts chemically with the zinc coating to form powdery flakes which can quickly clog the fuel filters and damage the fuel pump and injection nozzles.*

- **How to select fuel oil**

Fuel quality is an important factor in obtaining satisfactory engine performance, long engine life, and acceptable exhaust emission levels. HD Construction Equipment engines are designed to operate on most diesel fuels marketed today. In general, fuels meeting the properties of ASTM designation D975 (grades 1-D and 2-D) have provided satisfactory performance.

The ASTM 975 specification, however, does not in itself adequately define the fuel characteristics needed for assurance of fuel quality.

The properties listed in the fuel oil selection chart below have provided optimum engine performance. Grade 2-D fuel is normally available for marine service. Grade 1-D fuel should not be used in pleasure craft engines, except in an emergency.

**<Fuel oil selection chart>**

Property	ASTM D975 2GRADE		EN 590:2013	
Flash point, min	No 2D 52°C	D923	55°C	EN2719
Water & sediment, max.	0.05% vol.	D2709		
Water, max.			200 mg/kg	EN ISO 12937
Total contamination, max.			24 mg/kg	EN 12662
Distillation temperature (% vol recovered)	90%	D86	65%: 250°C	EN ISO 3405
	2D 282-338°C		85%: 350°C	
Kinematic viscosity (at 40°C)	2D 1.9-4.1 mm <sup>2</sup> /s	D445	2.0-4.5 mm <sup>2</sup> /s	EN ISO 3104
Density (at 15°C)			820-845 kg/m <sup>3</sup>	EN ISO 3675
				EN ISO 12185
Ester content	5% vol. max.	EN14078	7% vol. max. FAME	EN 14078
Ash, max.	0.01% wt	D482	0.01% wt	EN ISO 6245
Sulfur, max. (by mass)	2D	D5453	10	EN ISO 20846
	S15 15 mg/kg	D2622		EN ISO 20884
	S500 0.50%	D129 <sup>2</sup>		EN ISO 13032
	S5000 0.50%			
Copper strip corrosion, max.	No 3	D130	Class 1	EN ISO 2160
Cetane number, min.	40	D613	51	EN ISO 5165
Cetane index, min.			46	EN ISO 4264
- Cetane index	40 min.	D976-80		
- Aromaticity	35% vol. max.	D1319		
PAH, max.			11% wet	EN 12916
Operability, one of:	Report	D2500		
- Cloud point		D4539		
- LTFT/CFPP		D6371		
Cloud point			Location & sea- son dependant	EN 23015
CFPP			Location & sea- son dependant	EN 116
Carbon residue on 10% distillation residue, max.		D524	0.30% wt	EN ISO 10370
	2D: 0.35% wt			
Oxidation stability, max.			25 g/m <sup>3</sup>	EN ISO 12205
Lubricity (at 60°C), max.	520 μm	D6079 D7688	460 μm	ISO 12156-1
Conductivity, min.	25 pS/m	D2624 D4308		

\* If the sulfur content of the fuel is more than 0.5%, the replacement and inspection cycle should be cut in half.



**NOTICE:** The cloud point should be 6°C (10°F) below the lowest expected fuel temperature to prevent clogging of fuel filter by crystals.

### 4.6.3. Water Separator Cleaning

HD Construction Equipment recommends the fuel water separator to install between fuel tank and fuel injection pump strongly.

Condensation formed in a partially filled tank promotes the growth of microbial organisms that can clog fuel filters and restrict fuel flow and cause the engine power decrease before.

Drain the accumulated moisture of the water separator every 100 hours to prevent engine damage.

### 4.6.4. Fuel Filter Exchange

- Loosen the fuel filter by turning it counter-clockwise with the filter wrench. Discard the used filter a designated place.
- Wipe the filter fitting face clean.
- Supply fuel to the new filter and apply engine oil to the O-ring face lightly.
- Turn the new filter until the filter O-ring is fitted against the sealing face.
- And then turn the filter cartridge about 3/4 ~ 1 turn with hands.

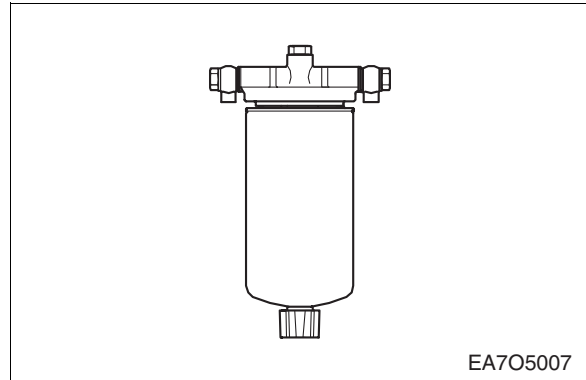

### Fuel system bleeding

Whenever fuel filter is changed or the engine is stopped by cause of the fuel lack, the air of fuel line must be removed as follows.

Bleed the fuel by manually operating the priming pump with fuel filter outlet joint bolt and injection pump bleeder screw loosened.

- Press the feed pump cap repetitively until the fuel without bubbles comes out from the bleeding plug screw.
- After the whole air is pulled out, close the plug screws of the filter and the pump.
- Confirm the resistance of fuel delivery by repetition pressing of the feed pump cap, Pressure and turn the priming pump cap simultaneously to close it.

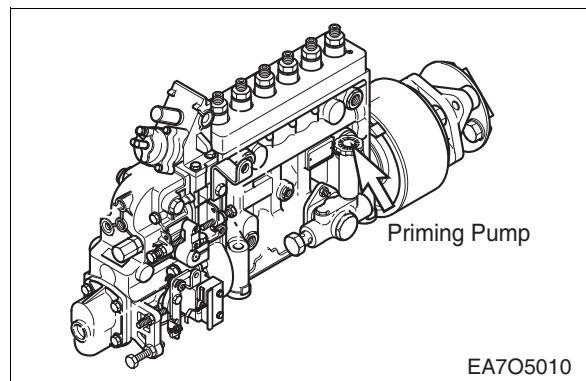

**NOTE:** Removing the seal ring (copper seal ring/rubber coated seal ring) when bleeding the fuel system replace it with a new one. Otherwise fuel leaks from the fuel filter joints, causing a critical fault in engine performance.

#### 4.6.5. Fuel Injection Timing Check (by authorized specialist personnel)

Check the fuel injection timing every year. Refer to details in "6.3.27. Injection pump & timing"



- CAUTION:**
- *Check the fuel injection pump housing for cracks or breaks, and replace if damaged.*
  - *Check whether the lead seal for idling control and speed control levers have been removed or not.*
  - *No alterations must be made to the injection pump. If the lead seal is damaged the warranty on the engine will become null and void.*
  - *We strongly recommend that any faults developing in the injection pump should be taken care of by authorized specialist personnel.*

#### 4.6.6. Injection Nozzle Check (by authorized specialist personnel)

Check the fuel injection nozzle every year or increasing the smoke excessively.  
Refer to details in "7.3.3. Fuel Injection Nozzle".

### 4.7. Electric System

#### 4.7.1. Warning Lamps Check

Check the lamps of the gauge panel carefully whether the lamp is switch on or not while the engine is running. The oil warning lamp should be switched on below 0.5 bar of the oil pressure and the water temp warning lamp should be switched off under 95°C of water temperature (normal condition).

#### 4.7.2. Battery Charge Check

Always check whether the battery capacity is sufficient or not before sailing far away from harbor.

#### 4.7.3. Wiring Harness Check

Check the engine wiring is loosened, shorted or worn every 600 hours.

## 4.8. Cylinder

### 4.8.1. Valve Clearance Adjustment

Usually should check the valve clearance of intake & exhaust every 1,000 hours after engine operation. Refer to "6.3.26. Valve clearance adjustment" details.



The valve clearances should be adjusted at the times of the following situations.

- After initial 50 hours operation.
- When the engine is overhauled and the cylinder heads are disassembled.
- When severe noise comes from valve train.
  - When the engine is not normally operated, even though there is no trouble in the fuel system.

### 4.8.2. Cylinder Compression Pressure Check

- Stop the engine after warming up, and take out nozzle holder assembly.
- Install the special tool (compression gauge adapter) at the nozzle holder hole, and connect the compression pressure gauge there.

Standard value	28 kg/cm <sup>2</sup>
----------------	-----------------------

\* Test Condition

Cooling water temperature 20°C,  
Engine rotation 200 rpm (about  
10 revolutions)

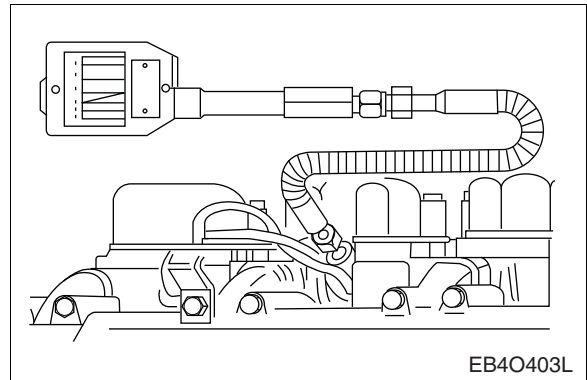

#### 4.9. Engine Preservation Points for a Long Time

Preserved engine for a long time should be prevented from corrosion or entering faulty matters. Especially the external and internal major components of the engine are likely to corrode. Please take care of the engine to maintain its good performance as follows.

- Drain the engine coolant completely and fill fresh water into the engine. Then run it sufficiently until washing out the engine coolant line.  
Finally drain the water, and refill new coolant (fresh water with 35 ~ 40% anti-freeze).
- Run the engine until the temperature of engine coolant is reached to normal condition (71 ~ 85°C), after then stop the engine.
- Drain engine oil by removing the drain plug of the oil pan or using the oil drain pump. Then refill new engine oil up to "MAX" mark line and change oil filter cartridge to new one.  
Prior to changing the oil, run the engine for 10 minutes. Drain engine oil while the engine is still hot. It is helpful to drain the faulty matters attached in the bottom of the oil pan.
- Close the valve or the cock of the fuel tank securely. Then detach the fuel filter and the water separator to clean them or replace with a new one.
- Run the engine about 5 minutes in order to circulate the new fuel through the all fuel lines completely.
- Disassemble the air filter to clean. If the element is fouled or worn severely, replace it with a new one.
- Drain the reduction gear oil completely, then clean the strainer that is assembled in the reduction gear.  
Refill the specified oil (SAE #30, above API CC grade) up to the "MAX" level.
- While the engine is running at idle rpm for 5 minutes, shift the control lever position of the reduction gear in turn (eg. "Neutral" - "Forward"- "Neutral" - "Reverse") to circulate the oil completely.
- Put the engine throttle lever at the idle position then reduction gear and FPTO lever at "switch off" position (Neutral & OFF).
- Drain the engine coolant completely and let the drain plugs removed.
- Close the kingston valve of the sea water line tightly. To avoid damage cause of freezing, drain the water of the heat exchanger, inter cooler, reduction gear oil cooler completely and keep the plugs opened.  
Finally don't forget to detach the sea water pump impeller and preserve it at a dark place.
- First of all, disconnect the battery wire (negative pole), then detach the other cables.  
Clean battery and all cables. After that replenish the distilled water for battery. (for refill type)  
HD Construction Equipment battery is maintenance free type, so there is no need to refill the water.  
To protect corrosion, apply the grease on the wire terminals of the battery.
- Loosen the V-belt (s) to release the pulley bearing from loaded tension and insert some pieces of paper between V-belt (s) and the pulley grooves.
- At least run the engine at idle rpm or a little more for 10 minutes once 10 days in order to lubricate all lubrication system and charge the batteries of the engine.
- The engine not used for a long time should be checked the condition regularly.  
Apply the grease on the engine parts to keep from rust.

#### **4.10. Management for Sunken Engine**

If the engine is sunk in sea water, remove the moisture of all engine parts as soon as possible and ask after service of your HD Construction Equipment dealer at once.

All parts of the engine should be disassembled to remove the salty moisture. After this, engine oil should be applied onto the parts at once. Finally check whether the components of the engine are dried, eroded away or damaged especially components of the fuel system. These actions must be finished quickly without delay. If not, engine fatal damage may result from salty corrosion.

Be sure to install the auto bilge pump in the bottom of the engine room. It can be a good solution to keep the water level below flywheel housing and to prevent overflowing with water.

## 5. Main Accessory Parts

### 5.1. Reduction Gear

Refer to "reduction gear manual" provided with engine separately for detail operation and maintenance of reduction gear.

#### 5.1.1. Construction and Operation

The reduction gear is used for high-speed engine and consists of 4 major components such as input shaft, gear shaft, output shaft, and housing.

The clutch for forward and reverse movements is composed of a hydraulic wet-type and multiplate type. The construction and power line is as follows;

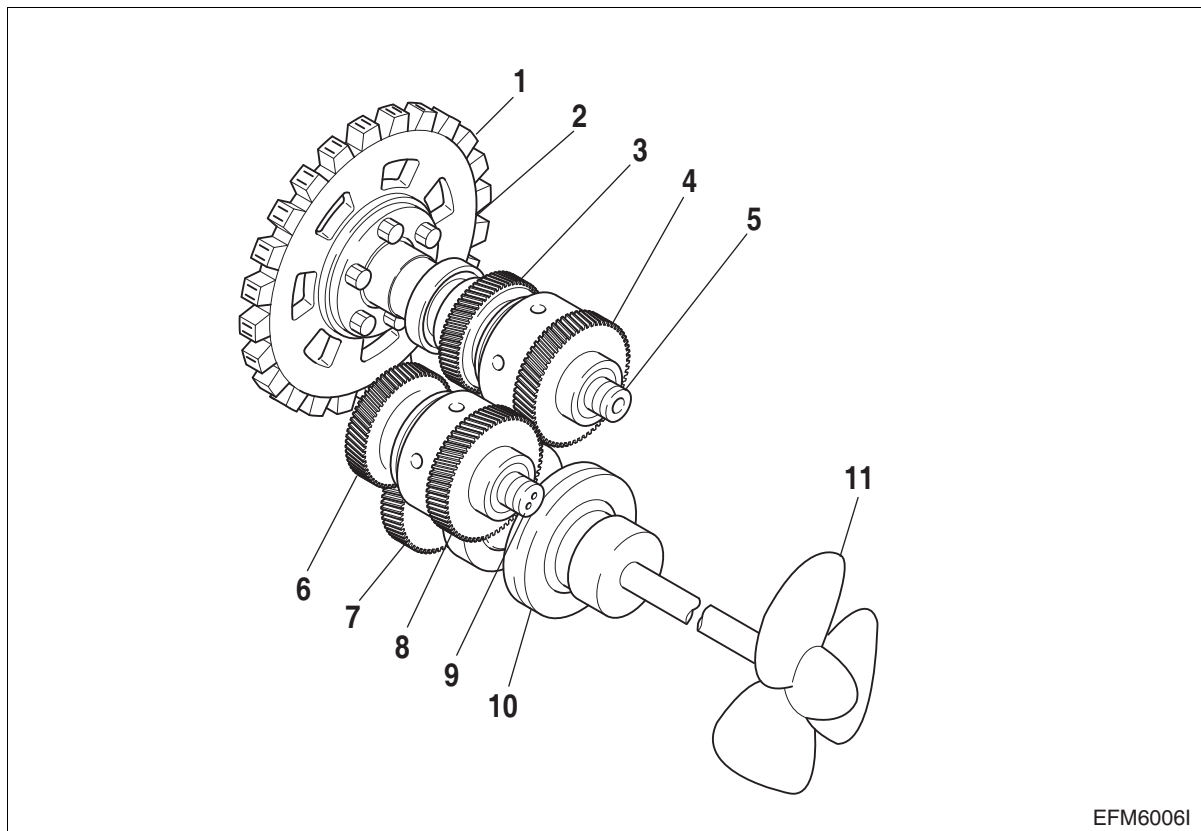

#### <Power line>

Neutral : 1-2-5-4-8

Forward : 1-2-5-3-7-10

Reverse : 1-2-5-4-8-9-6-7-10

- |                       |                       |
|-----------------------|-----------------------|
| 1. Rubber block       | 6. Reverse pinion     |
| 2. Spider             | 7. Output shaft       |
| 3. Forward pinion     | 8. Reverse drive gear |
| 4. Reverse drive gear | 9. Gear shaft         |
| 5. Input shaft        | 10. Propeller shaft   |

### 5.1.2. Characteristics

The hydraulic-type clutch is composed of forward main body, reverse main body, output shaft, and selector valve.

The selector valve assembly installed on the external part is a device designed to control forward, neutral, and reverse movements and also it can be remote-controlled. The oil pumped up at the pump supplies hydraulic pressure for the clutch assembly, lubricating portions on gear and bearings, and cooling system. But when assembling this hydraulic type clutch, use care so that it is aligned with the engine correctly.

### 5.1.3. Operation

#### 1) Before operation

- Check the tightening bolts and nuts on the components as a whole for looseness.
- Check the oil level with the oil level gauge.  
(Run the engine at idle for a few minutes, then stop it before checking the oil level.)
- Place the control lever in the neutral position before starting the engine.

#### 2) Starting

- Run the engine at idle for about 10 minutes.
- Check for oil leaks, unusual sound, temperature, etc. during the engine idling.
- While checking the clutch pressure, increase the engine rpm.

#### 3) Driving and stopping

- Check to see that the specified pressure is obtained when engaging the clutch.  
The pressure may drop slightly at low engine rpm, but it does not affect the operation of the engine.
- When attempting to change gears for forward or reverse movement, first put the engine rpm at idle.
- The temperature of oil at operation must be 60 ~ 90°C.
- When attempting to stop the engine, be sure to place the control lever in the neutral position.

4) Emergency bolt

The emergency bolt is designed to couple the clutch mechanically when the clutch indicates abnormal condition or slip at clutch coupling operation. The reverse clutch pack has no emergency bolt. When using the emergency bolt, first loosen the tightening bolts to remove the control block, tighten the 8 mm wrench bolt on the forward disc pack using a 5 mm L-shaped wrench, then reassemble the control block in the reverse order. Be sure to use this emergency bolt literally in case of emergency.

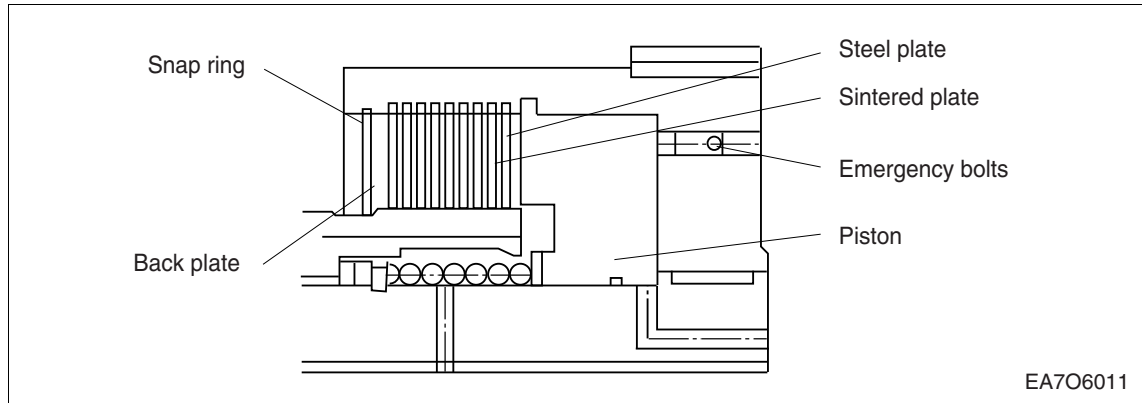

**5.2. Front Power Take-Off (F.P.T.O)**

**5.2.1. For Maximum FPTO Power**

For front power take-off in line with crankshaft, it is a standard procedure to support driveshaft and V-pulley by two pillow blocks by using flexile coupling for connection to engine.

When the front PTO is installed, be sure to take deflection reading. Radial runout should be no more than 0.02 mm.

Be sure to limit the front PTO output within the maximum allowable horsepower as specified for each model. (Torque represents when there is no propeller load)

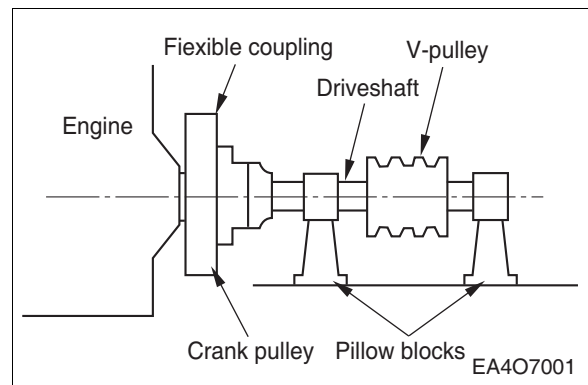

Model	Load (kW)	rpm	Model	Load (kW)	rpm
L136	60	1,600	L136TI	88	1,600
L136T	72	1,600	L086TI	105	1,600

### 5.2.2. For Small Cross Drive Power

The figure is applicable to the drive arrangement (No supporting bearing on front side of PTO pulley) in which the distance between the end face of the engine pulley and the centerline through pulley groove is not greater than 60 mm. The distance is indicated as L in the figure.

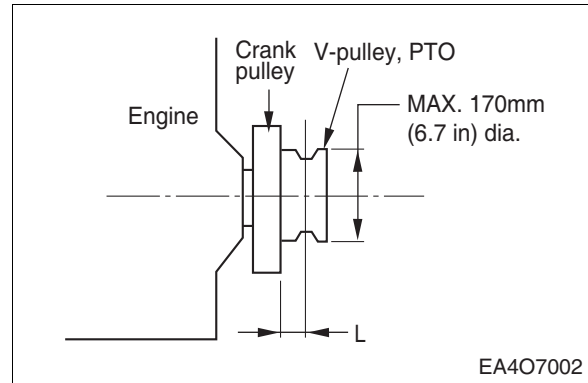

Model	L mm	Belt driven side load (kW)	rpm
L136	60	35	1,600
L136T		40	
L136TI		50	
L086TI		62	

### 5.3. Propeller Selection

Your dealer has chosen a propeller designed to deliver top performance and economy under most conditions. To obtain the maximum percentage of available horsepower (A), the engine RPM at full throttle should be in the specified full throttle operating range (B). Refer to specifications in performance curve.

If the engine's full throttle RPM on normal load is below the specified on the low side of the range (C), use a propeller with less pitch to increase the RPM.

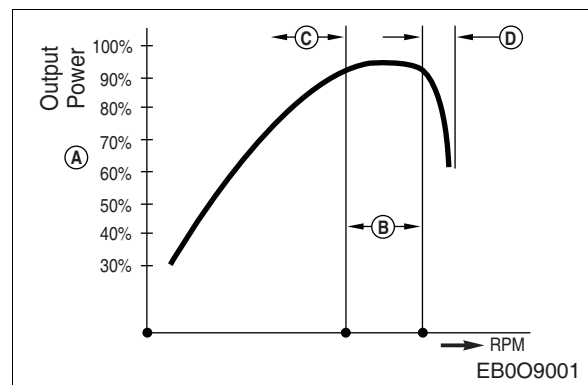

Should the engine's full throttle RPM want to exceed the specified range (D), the engine RPM is limited by the governor. Use a propeller of higher pitch to stop the limiting by the governor.



**NOTE: Engine damage can result from incorrect propeller selection which:**

- (C) Prevents engine RPM from attaining the specified "Full throttle operating range". Engine is laboring, install lower pitch propeller.
- (D) Allows engine RPM above the specified "Full throttle operating range". Engine RPM is limited by the governor, install a higher pitch propeller.

## 5.4. Electric System

### 5.4.1. Alternator

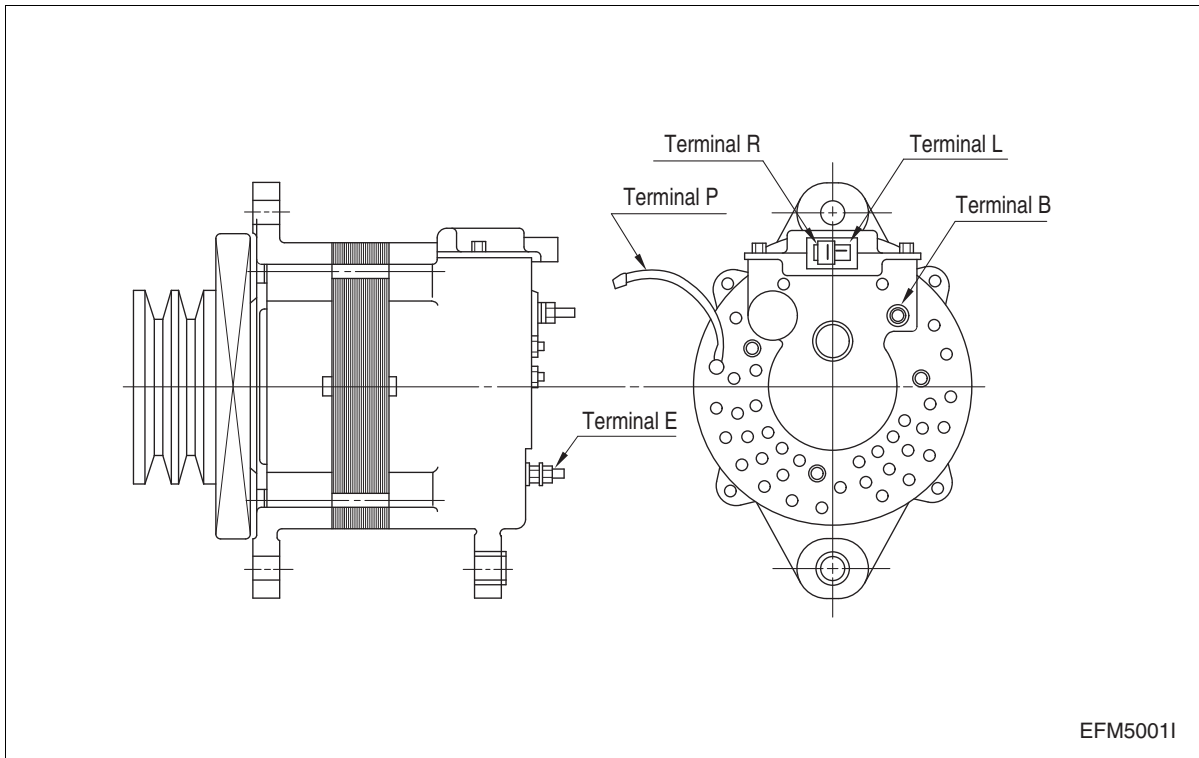

The alternator is fitted with integral silicon rectifiers. A transistorized regulator mounted on the alternator limits the alternator voltage evenly. The alternator should be operated with the regulator and battery connected in circuit to avoid the damage of the rectifier and regulator. The alternator is maintenance free, but it must be protected against dust and above all against moisture therefore it must be mounted a cover for protector properly.

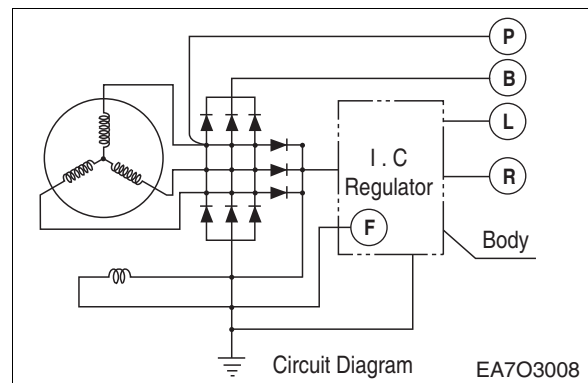

#### 1) Inspection point (In case of abnormal charging)

- Voltage measurement between terminal and alternator body during operation.

<Voltage during operation>

Measuring point	Voltage
Terminal B - Body	about DC28V ~ 29V
Terminal L - Body	about DC28V ~ 29V
Terminal R - Body	about DC28V ~ 29V

<Voltage during stop>

Measuring point	Voltage
Terminal B - Body	about DC24V
Terminal L - Body	about DC2V
Terminal R - Body	about DC24V



*For the confirmation of wiring state, measurement of voltage should be carried out only at each terminal during engine stop.*

- **Inspection points on the voltage regulator**

<Resistance value between voltage regulator's terminals>

Terminal		Resistance Value (KΩ)
+	-	
L	E	about 2
R	E	about 53
F	E	about 50
L	F	about 50
R	L	about 50
R	F	about 168

Terminal		Resistance Value (KΩ)
+	-	
E	R	∞
L	R	∞
F	R	∞

## 2) Precautions in use

- Pay attention to dropping the battery voltage capacity when they are left for long time even without use.
- In cold winter season, for the starting may not be done well sometime, do not try it to be continuous immediately but try to start again after waiting about 30 seconds.
- Prior to operating the gauge panel, make sure of the polarity of battery once again (In general, red side means "+" and black one is "-".)
- Disassembling the gauge panel may be accompanied with a risk of electrical shock, First detach the cable from the connector at the rear side of the gauge panel without fail, then disassemble it.
- If metallic foil is used for safety connector instead of the cut-off fuse, excessive current that can make serious damage might flow into the electric parts of the engine. (Never do this!) If cutting off of fuse is occurred, solve the problem, then replace it with a new fuse.
- Since battery has a danger of explosion by a heat, it must not be installed at the place where there generates a lot of heat.
- When engine is in stop, always pull out the key. Then a hazard of fire or wound due to wrong operation may not happen.
- In case of scrapping the batteries, observe the followings.



**NOTE:** *Do not throw it in the fire to scrap. It should not be thrown away into the places where are liable to cause the environmental pollution such as stream, river and mountain.  
Pack them as far as possible and dispose it as rubbish that is unable to use again.*

- HD Construction Equipment will not be responsible to the problems that might be raised by the disassembling and structural change of this product without consultation.

### 5.4.2. Starter Motor

The starter motor is installed on the flywheel housing.

When the starter key switch is turned on, the starter motor pinion flies out and engages the ring gear of the flywheel. Then the main contact is closed, current flows, and the engine is started.

After the engine starts, the pinion automatically returns to its initial position as soon as the starter key switch is released.

Otherwise, the starter motor may be damaged or burned out.

In case of repairing the engine, dip the pinion of the starter and ring gear into the new fuel, then remove the dirty or corrosion with a brush.

After that, apply the grease on them to protect the corrosion.

Whenever you clean the starter, always pay attention not to occur the electric short due to entering the water.

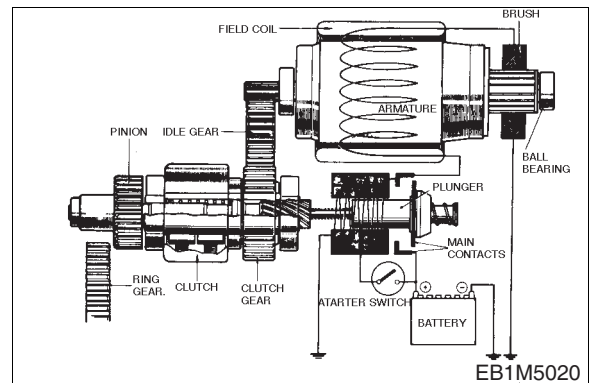

EB1M5020



**Starter motor always should be protected from humidity.**



**Precaution: Before the maintenance of the electric system, be sure to detach the battery wire (-) to avoid the electric short.**

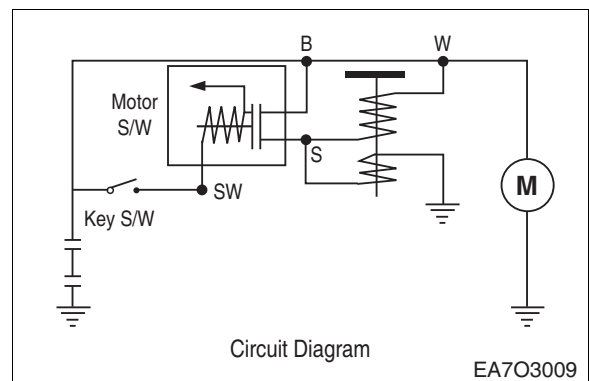

Circuit Diagram

EA7O3009



## 6. Disassembly and Assembly of Major Components

### 6.1. Disassembly

#### 6.1.1. General Precautions

- Maintenance operation should be carried out in a bright and clean place.
- Before disassembly, provide racks for arrangement of various tools and disassembled parts.
- Arrange the disassembled parts in the disassembly sequence and use care to prevent any damage to them.

#### 6.1.2. Cooling Water

- Remove the drain plug from the cylinder block and under side of oil cooler, then drain out the cooling water into a container.

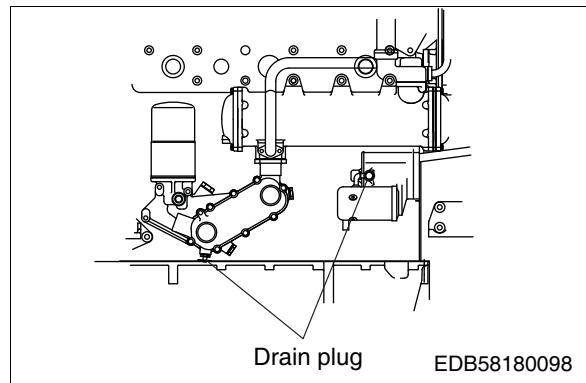

#### 6.1.3. Engine Oil and Drain Pump

- Drain out the engine oil into a container using oil drain pump.
- Remove the oil hose from oil pan and reduction gear.
- Unscrew the oil drain pump fixing bolts and disassemble the oil drain pump.

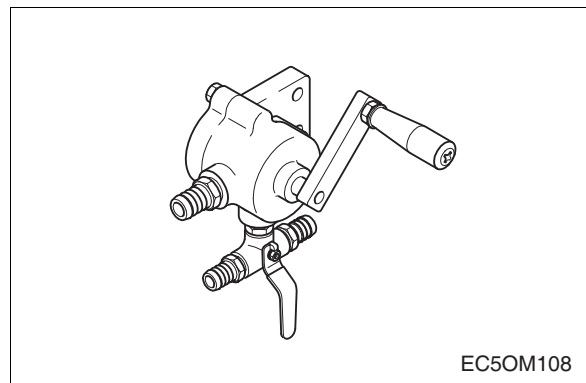

#### 6.1.4. V - belt

- Loosen the tension adjusting nut installed on the alternator support, and take off the V -belt.

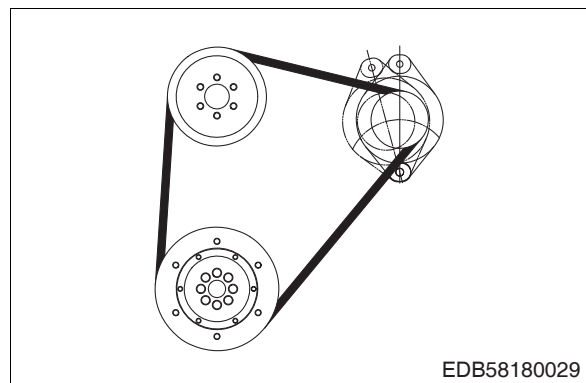

### 6.1.5. Alternator

- Remove the electric wires and the alternator fixing bolt and then disassemble the cover and alternator.
- Remove the tension adjusting bolt and bracket.

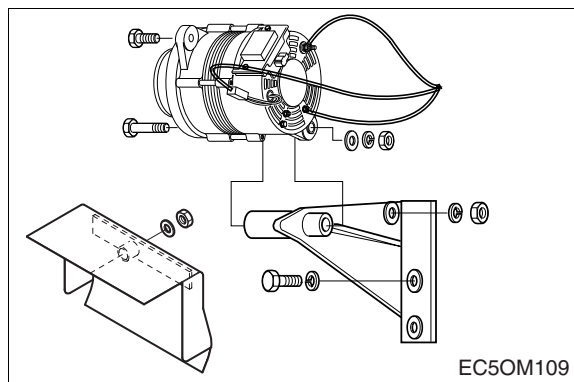

### 6.1.6. Fuel Filter

- Remove fuel hoses connected to the fuel injection pump, take off the filter housing fixing bolts, then disassemble the fuel filter.

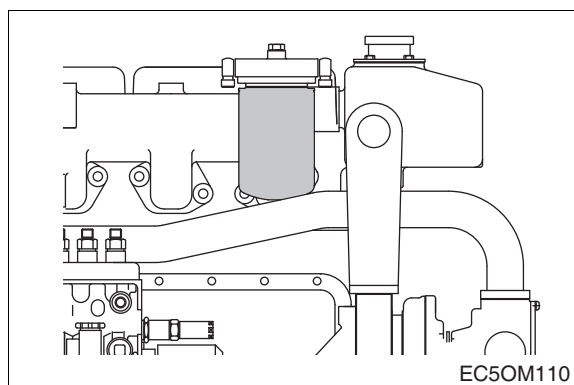

### 6.1.7. Breather

- Loosen the clamp screw to remove the rubber hose and the breather after unscrew.

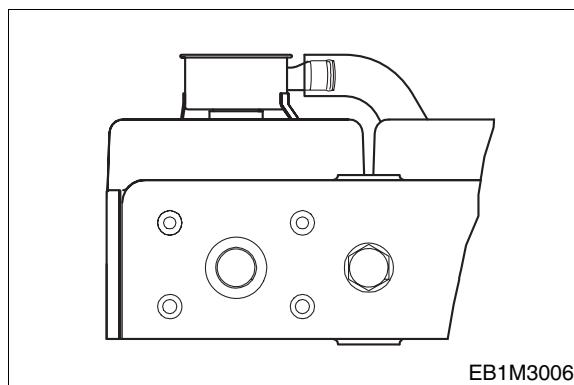

### 6.1.8. Inter Cooler

- Remove the cooling water pipe from inter cooler to marine gear oil cooler.
- Remove the air pipe connected to intake manifold and turbocharger.
- Disassemble the intercooler after unscrew the mounting bolts on the heat exchanger.

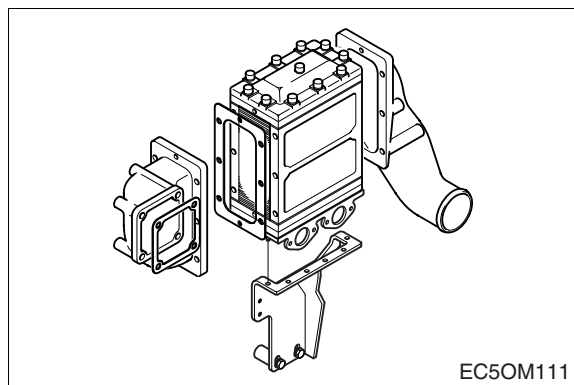

### 6.1.9. Air Cleaner

- Remove the air filter element.
- Loosen the clamp, then remove the air cleaner.

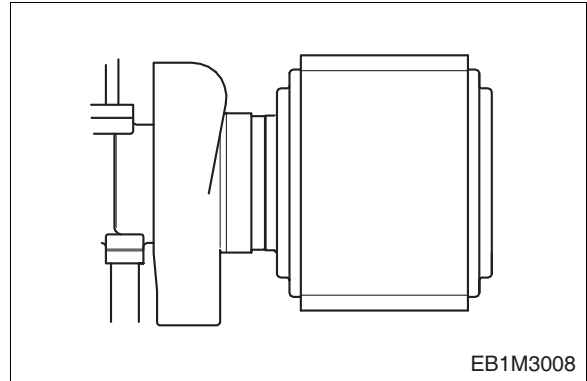

### 6.1.10. Turbo Charger

- Loosen the clamp screw of the rubber hose connected to the inter cooler, and take off the intake pipes both simultaneously.
- Unscrew the exhaust pipe flange fixing bolts and the nuts installed on the turbocharger, then take out the exhaust pipe.
- Remove the turbocharger after removing the oil supply pipe and return pipe including both inlet and outlet cooling water pipes.

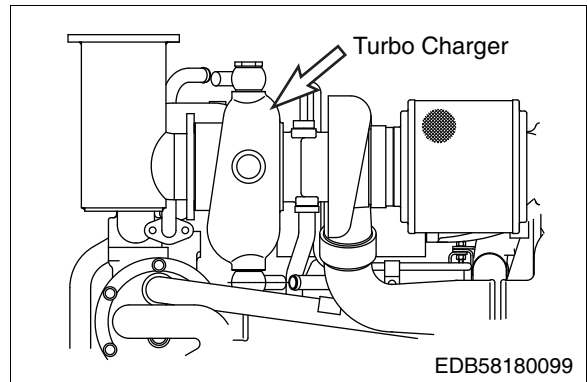

### 6.1.11. Expansion Tank

- Remove the reservoir tank and hoses connected to the expansion tank.
- Loosen the expansion tank bracket fixing bolts then remove the expansion tank.

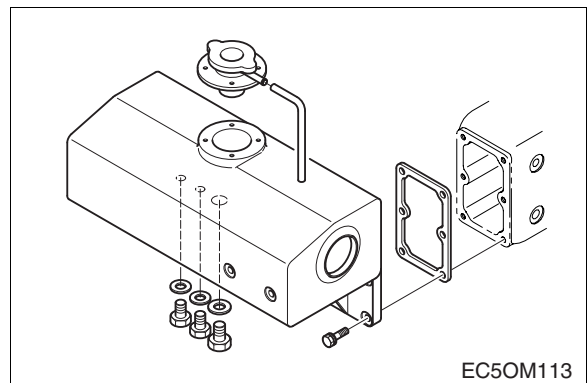

### 6.1.12. Stop Solenoid

- Remove the cable from the fuel stop lever to the stop solenoid.
- Disassemble the stop solenoid.

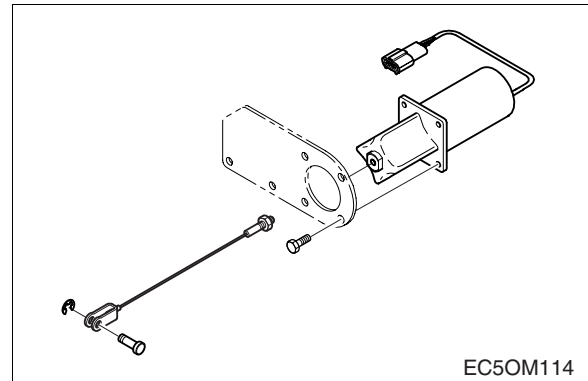

### 6.1.13. Injection Pipe

- Unscrew the hollow screws to disassemble the fuel return pipe.
- Remove the nuts installed on the fuel injection pump and the injection nozzles, then disassemble the injection pipe.

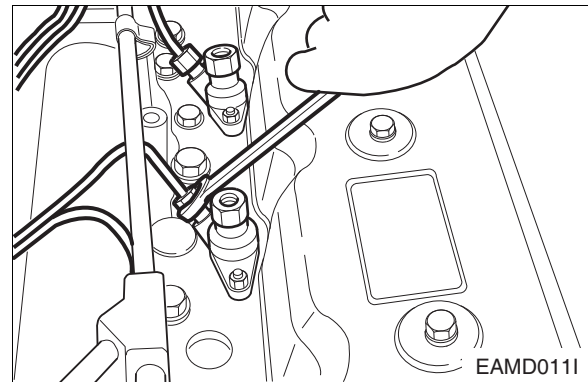

### 6.1.14. Intake Manifold

- Remove the hoses connected to the injection pump and fuel filter and intake manifold.
- Loosen the intake manifold fixing bolts, then disassemble the intake manifold.

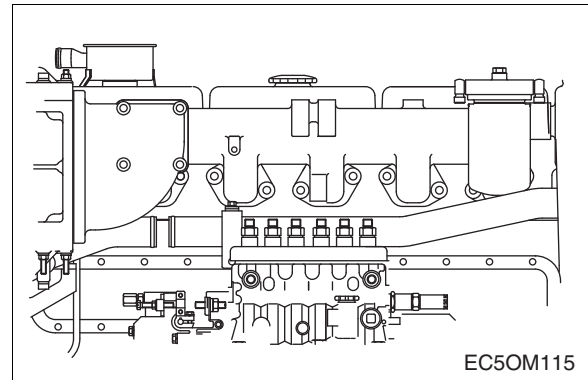

### 6.1.15. Thermostat

- Release the hose clamps connected to the both portion of the heat exchanger and cooling water pipe.
- Remove the thermostat housing assembly, and unscrew the mounting bolts, then take off two thermostats.

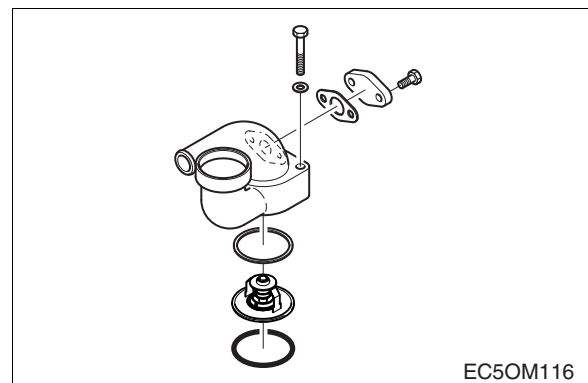

### 6.1.16. Heat Exchanger

- Loosen the clamp on the rubber hoses connected to the inter cooler and cooling water pipe of the heat exchanger, and remove the inter cooler then take off the rubber hoses.
- After remove the inter cooler, unscrew the heat exchanger fixing bolts, then detach the heat exchanger.

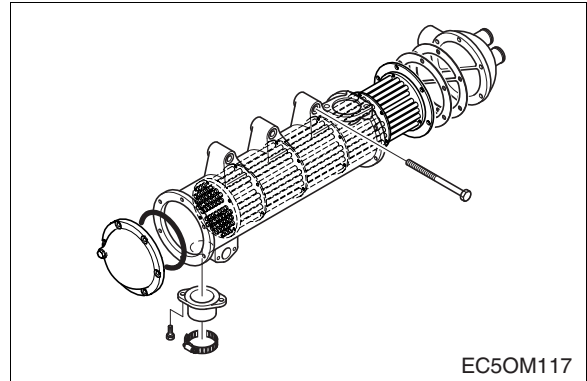

### 6.1.17. Exhaust Manifold

- Remove the cooling water pipes on the front and upper side and then exhaust outlet pipe.
- Unscrew the exhaust manifold fixing bolts, and then detach the exhaust manifold and gaskets.



**CAUTION:** *The exhaust manifold is very heavy. Be careful to handle it.*

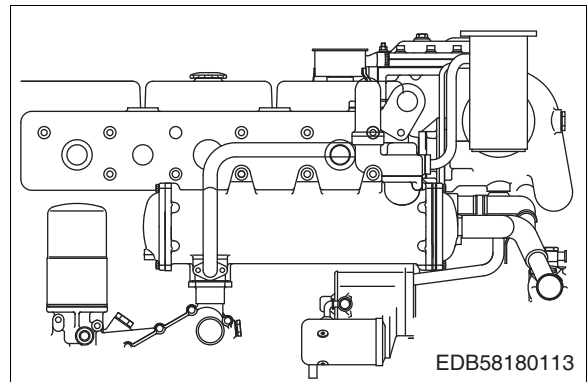

### 6.1.18. Starter

- Unscrew the starter fixing bolts, then disassemble the starter.

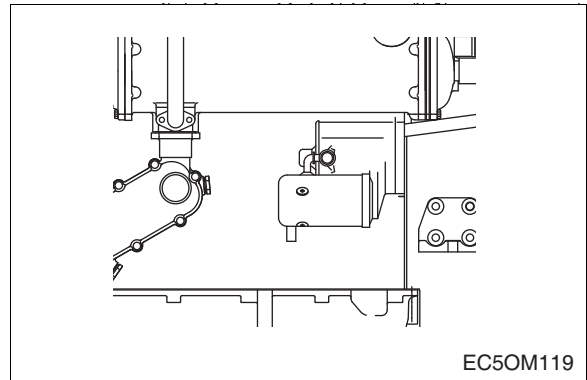

### 6.1.19. Sea Water Pump

- Release the clamp on the rubber hose connected to the sea water pipe then detach the rubber hose.
- Unscrew the sea water pump fixing bolts, then remove the sea water pump.

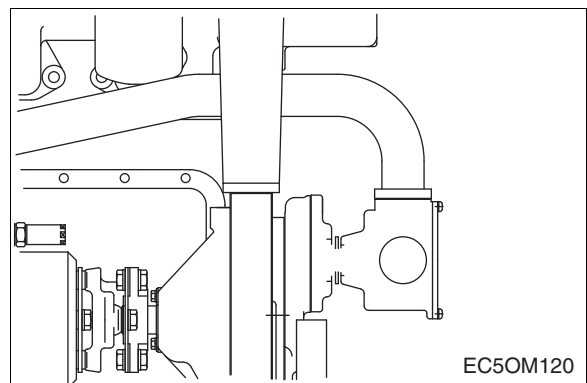

### 6.1.20. Water Pump

- Remove the expansion tank and rubber hose connected to the expansion tank.
- Remove the water pipe and hoses connected to the oil cooler.
- Unscrew the water pump fixing bolts and remove the water pump.

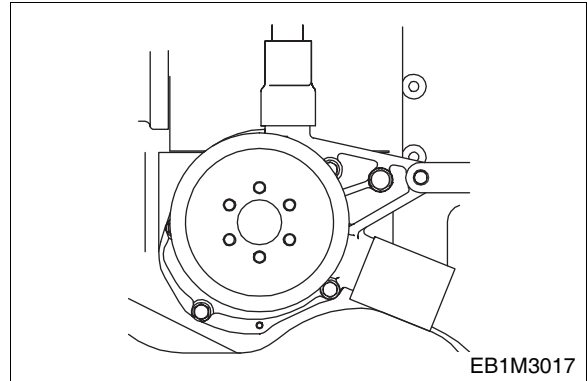

### 6.1.21. Injection Pump

#### (A) L086TI

- Remove the oil supply pipe and the return pipe connected to the fuel injection pump.
- Unscrew the bolts connected the coupling and drive shaft, disassemble the injection pump mounting bolts, then detach the injection pump.



**NOTE:** After letting No.1 cylinder to the 'OT' position by turning the crankshaft, disassemble the injection pump.

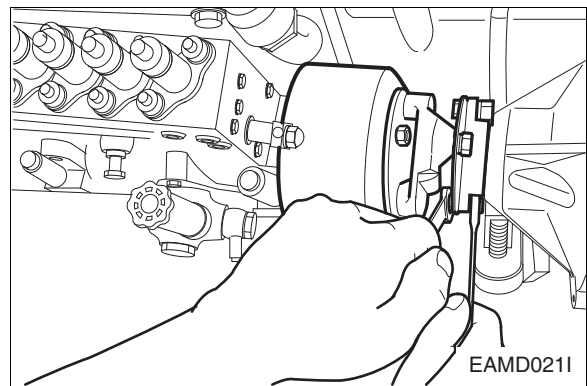

- Unscrew the pump bracket fixing bolts to detach the bracket from the cylinder block.



**NOTE:** Do not mix the disassembled shims. They should be reassembled to the original position.

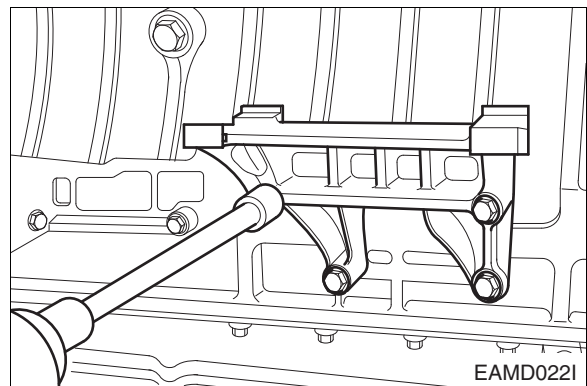

### (B) L136/T/TI

- Put the piston (No.1) of the engine to O.T position, then remove the timing gear case cover, and engrave a line on the both flanges as the figure. (This is only for no engraved line before.)
- Remove the injection pump.

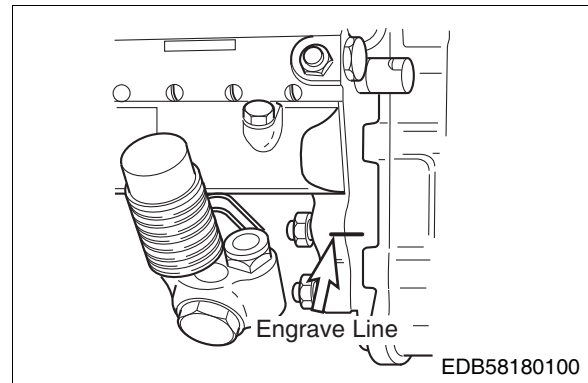

To exchange the injection pump for new one, put the piston (No.1) of the engine to O.T position, then mark the line temporary by using oil paint at the geared point between injection pump gear and idle gear separately.

This marking is used to assemble the injection pump gear to reassemble the new injection pump. (Refer to 6.3.27. (b).)

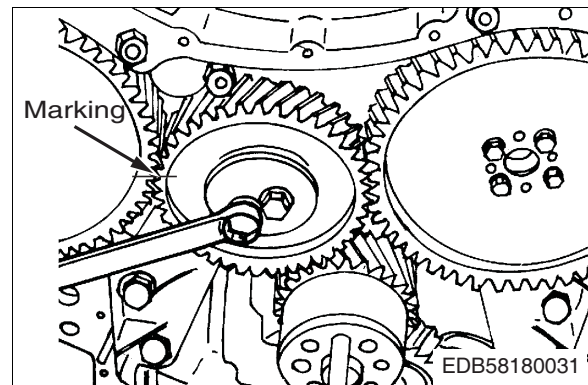

### 6.1.22. Oil Filter

- Detach the pipes connected to the water pump and heat exchanger. Remove the oil filter cartridge using a filter wrench.
- Unscrew the oil filter fixing bolts and detach the oil filter and cooler assembly from the cylinder block.

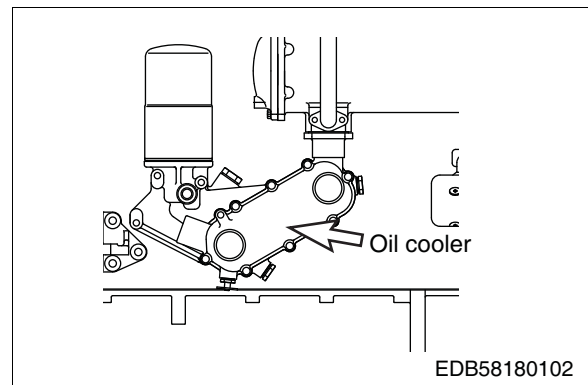

### 6.1.23. Vibration Damper

- Unscrew the pulley fixing bolts and disassemble the pulley-vibration damper assembly.
- Unscrew the vibration damper fixing bolts and detach the damper from the pulley.

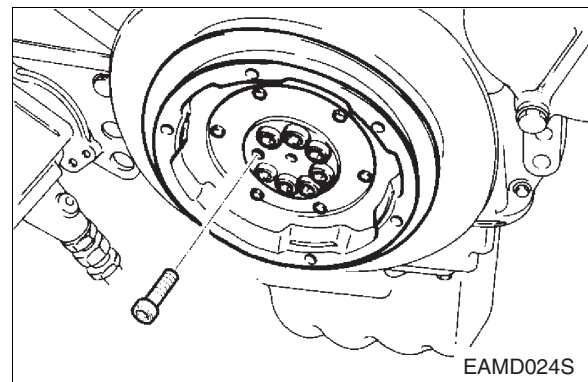

#### 6.1.24. Timing Gear Case Cover



- Disassemble the oil seal using the removing jig.
- Unscrew the cover fixing bolts and disassemble the cover from the timing gear case.

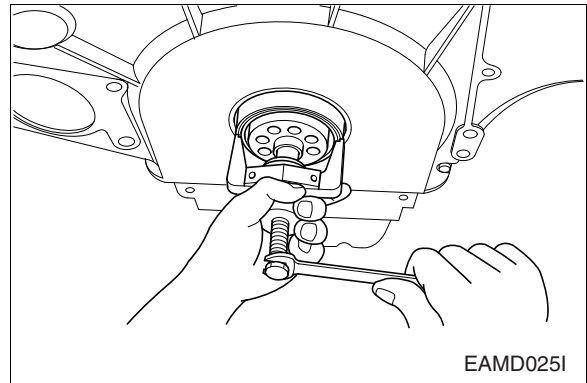

#### 6.1.25. Idle Gear

- Unscrew the idle gear fixing bolts and disassemble the thrust washer and idle gear.
- Disassemble the idle gear pin using a rubber hammer to prevent them from damaging.

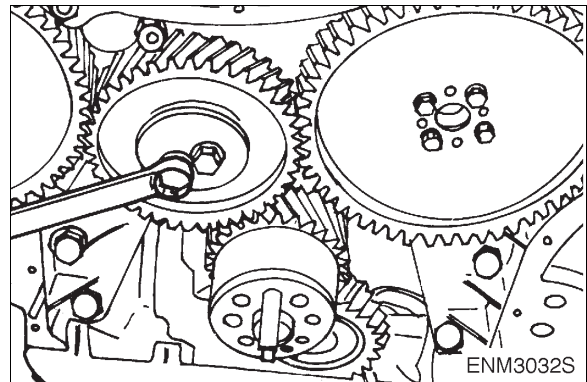

#### 6.1.26. Injection Pump Drive

- Unscrew the drive shaft bearing housing fixing bolts and remove the injection pump drive assembly like as the shaft, gear, bearings, and housing are put together.

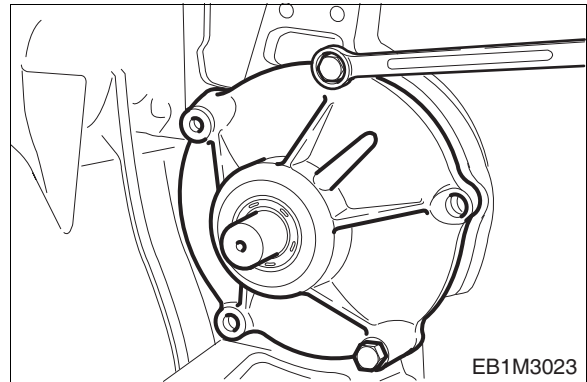

#### 6.1.27. Cylinder Head Cover

- Unscrew the head cover fixing bolts and disassemble the cover.
- Keep the bolts in an assembly state so that the packing and washers may not be lost, and keep the cover packing as assembled with the cover.

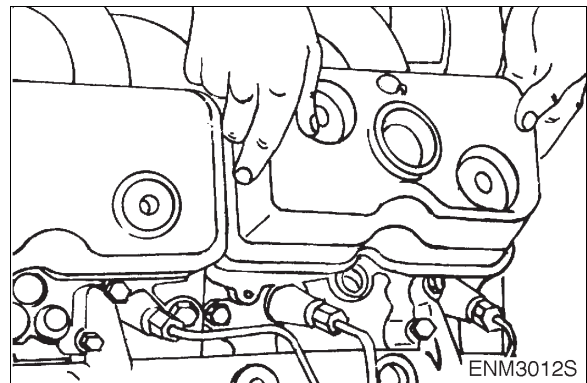

### 6.1.28. Rocker Arm Assembly

- Unscrew the rocker arm bracket bolts and remove the rocker arm assembly.
- Take off the snap rings to remove the washers and rocker arm, then unscrew the bracket fixing bolts to take off the bracket and springs.

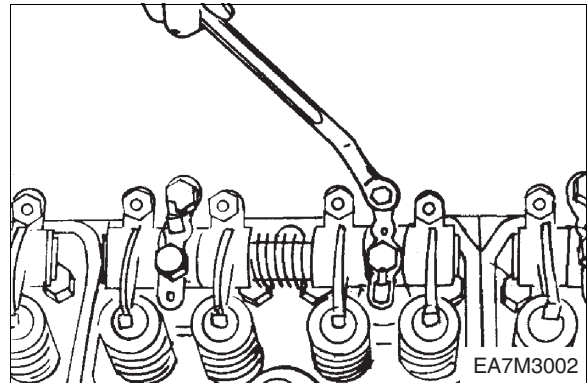

- Take out the push rods.

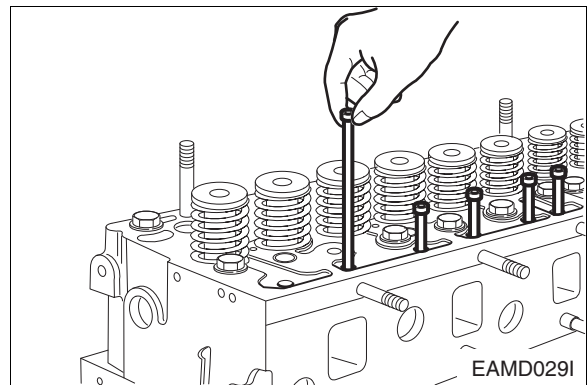

### 6.1.29. Injection Nozzle



- Take off the injection pipes between the injection pump and injection nozzles.
- Remove the nozzle holder assembly using the nozzle removing jig.



***Do not disassemble the injection nozzle unless coolant or gas comes out.***

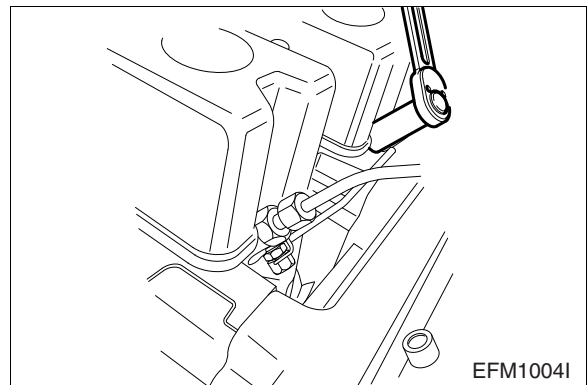

### 6.1.30. Cylinder Head

- Unscrew the cylinder head fixing bolts and take off the cylinder heads.
- Remove the cylinder head gaskets.

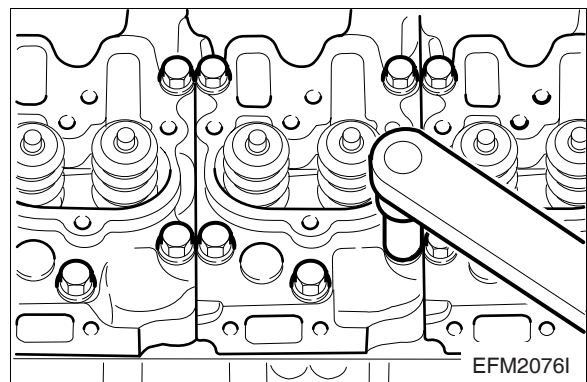

### 6.1.31. Valve & Stem Seal



- Compress the valve spring retainer using a jig and take off the valve cotter pins.
- Disassemble the valve springs and retainers.
- Take off the valves.
- Remove and discard the used valve stem seals in order not to be re-used.

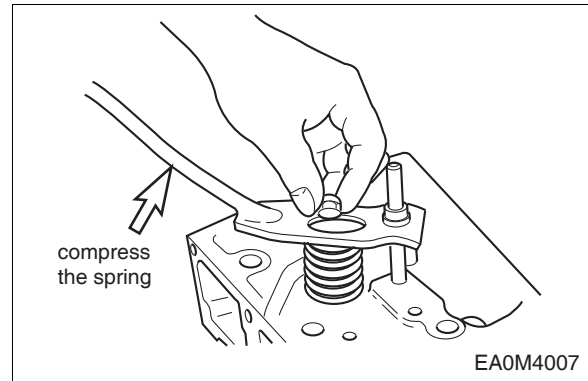

### 6.1.32. Oil Cooler

- Unscrew the oil cooler cover fixing bolts and disassemble the oil cooler tube assembly from the oil cooler housing.

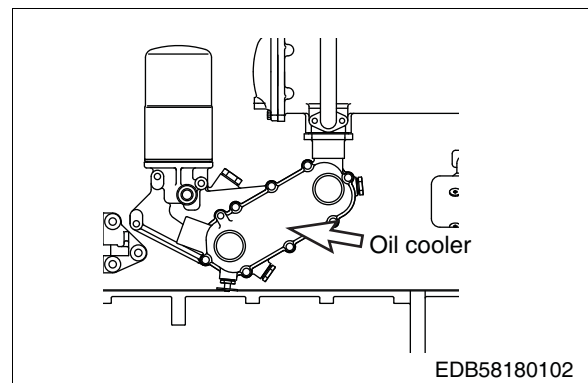

### 6.1.33. Oil Pan

- Stand the engine up the flywheel housing end face towards the bottom side.
- Release the oil pan fixing bolts, then disassemble the oil pan.

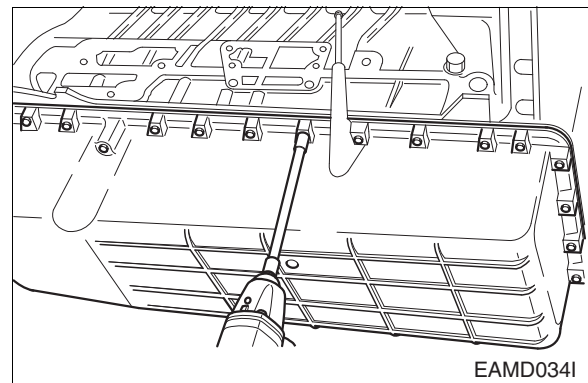

### 6.1.34. Oil Pump & Oil Pipe

- Unscrew the oil suction pipe bracket bolts, releasing the pipe fixing bolts, then detach the oil suction pipe assembly.
- Disassemble the oil pipes connected the oil pump to the cylinder block.
- Unscrew the oil pump fixing bolts and disassemble the oil pump.

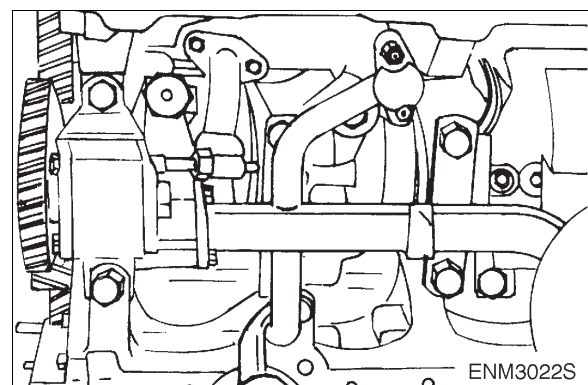

### 6.1.35. Relief Valve

- Unscrew the relief valve housing fixing bolts
- Disassemble the relief valve from the housing.

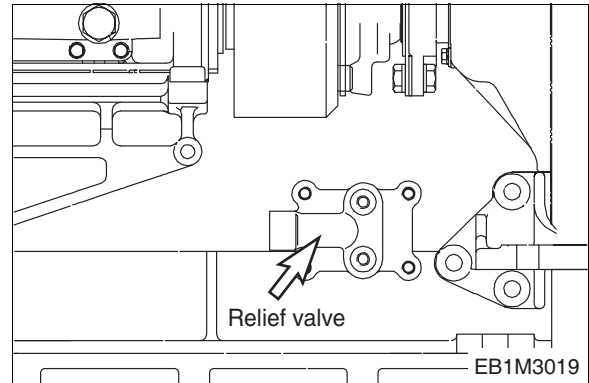

### 6.1.36. Piston and Connecting Rod

- Disassemble the pistons by two cylinders while turning the crankshaft.
- Unscrew the connecting rod fixing bolts and take off the pistons and connecting rods in the direction of piston upper side.

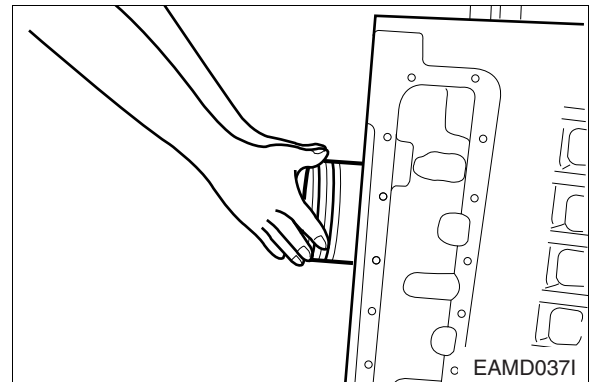

- Remove the piston pin and snap rings, then disconnect the connecting rod from the piston.

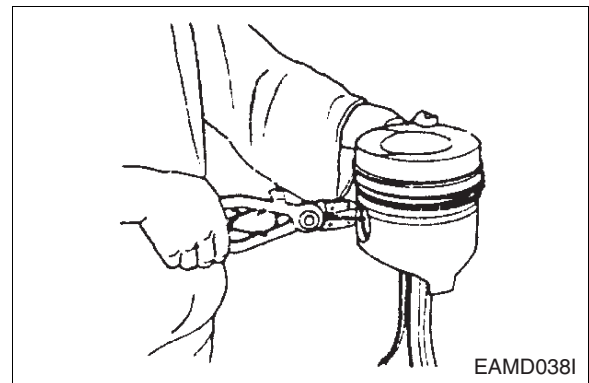

- Disassemble the piston rings using a ring pliers.
- Arrange the disassembled parts carefully in order not to interchange each other and keep them in the sequence of cylinder number.

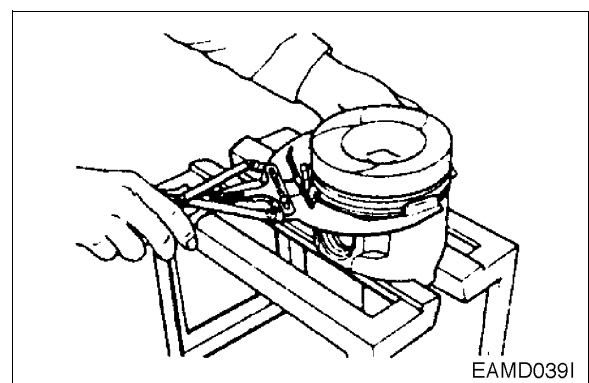

### 6.1.37. Cylinder Liner

- Take off the cylinder liner.

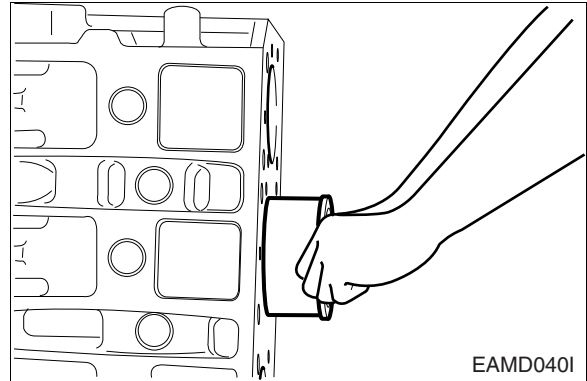

### 6.1.38. Flywheel

- First remove two fixing bolts of the flywheel and install the two dowel pins in the bolt hole.
- Unscrew the last flywheel fixing bolts, and then detach the flywheel with care.

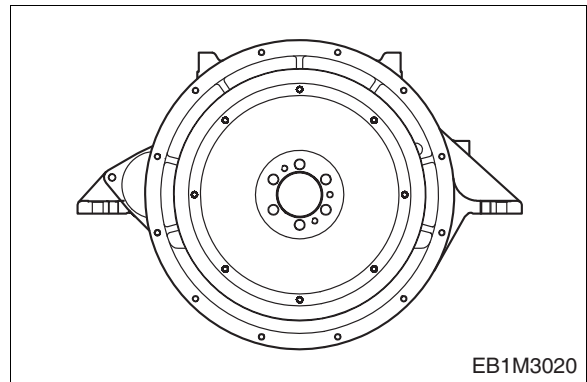

### 6.1.39. Oil Seal



- Take off the rear oil seal using an oil seal disassembling jig.

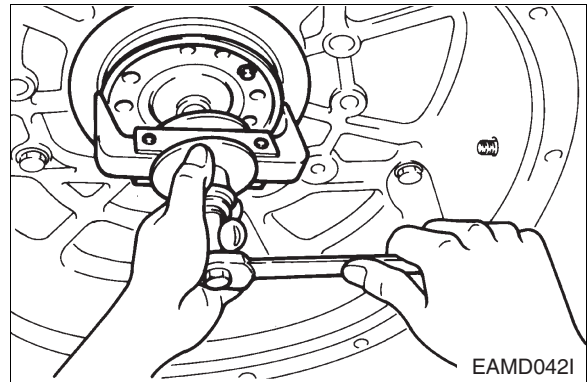

### 6.1.40. Flywheel Housing

- Loosen the housing fixing bolts, then disassemble the flywheel housing.

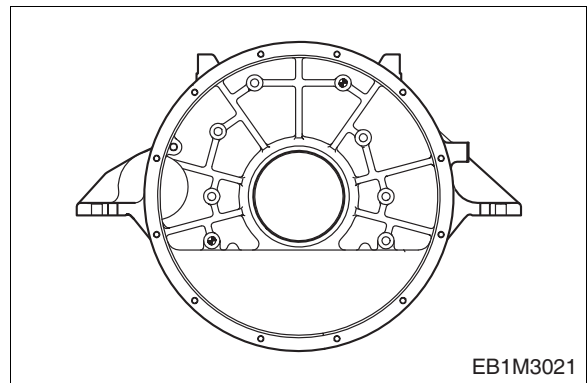

#### 6.1.41. Cam Shaft and Tappet

- Remove the camshaft gear and thrust washer.
- Take out the camshaft with care not to damage it and inner bearings.
- Take out the tappets by hand.

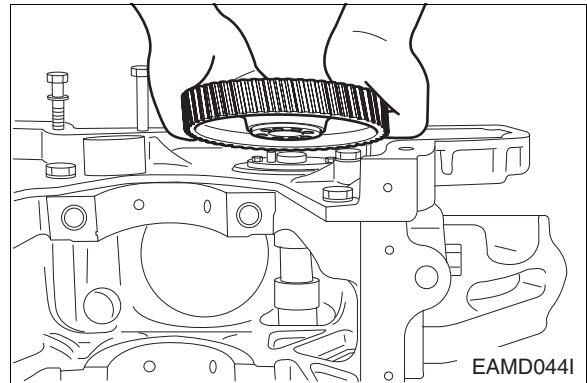

#### 6.1.42. Crankshaft Gear and Oil Pump Idle Gear

- Loosen the socket head bolts and take out the oil pump idle gear.
- Use a puller of special tool to remove the crankshaft gear.

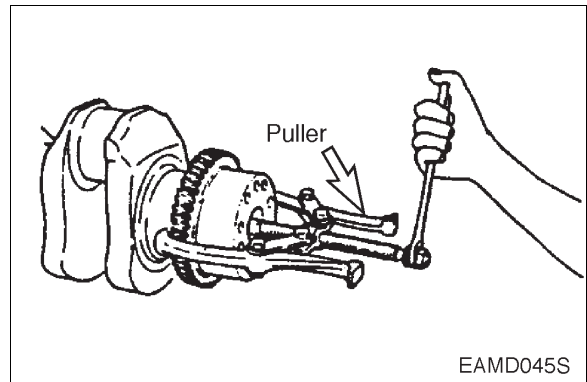

#### 6.1.43. Timing Gear Case

- Unscrew the case fixing bolts and disassemble the timing gear case.

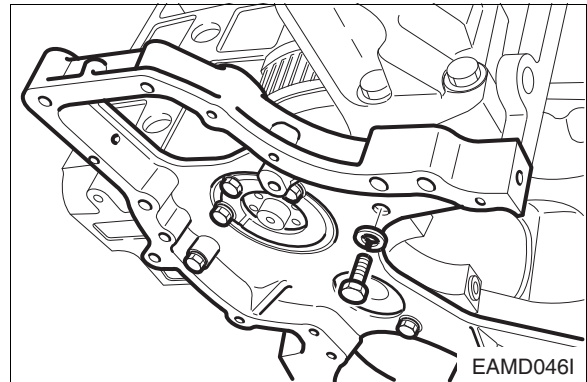

#### 6.1.44. Crankshaft and Bearing Cap

- Unscrew the main bearing cap fixing bolts and remove the bearing caps.
- Take off the crankshaft.
- Detach the main bearings.

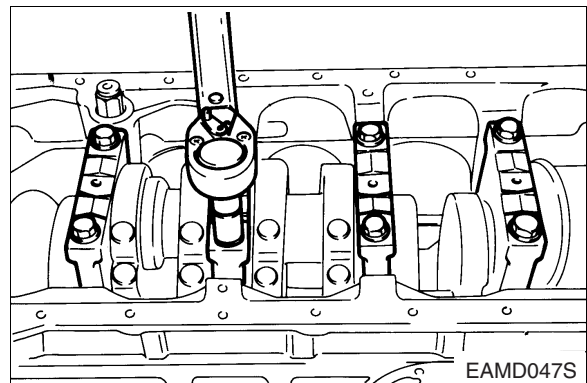

#### 6.1.45. Oil Spray Nozzle

- Unscrew the fixing bolt and remove the oil spray nozzles.

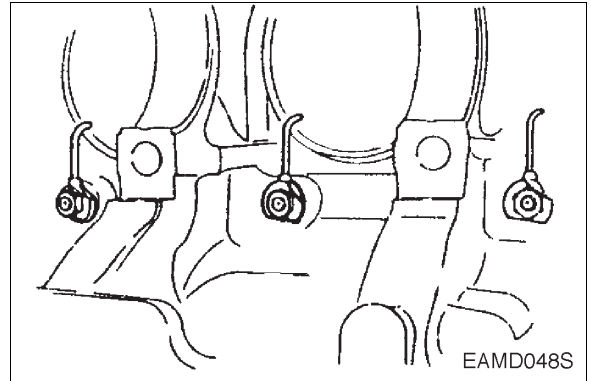

## 6.2. Inspection

### 6.2.1. Cylinder Block



- 1) Clean the cylinder block thoroughly and check a visual inspection for cracks or damage.
- 2) Replace if cracked or severely damaged, and correct if slightly damaged.
- 3) Check the oil and water passing lines for restriction or corrosion.
- 4) Make a hydraulic test to check for any cracks or air leaks.

**Hydraulic test:** Stop up each outlet port of water and oil passages in the cylinder block, apply air pressure of about 4 kg/cm<sup>2</sup> against the inlet ports, then immerse the cylinder block in water for about 1 minute to check any leaks.  
(Water temperature: 70°C)

### 6.2.2. Cylinder Head



#### 1) Inspection of cracks and damage

- Carefully remove carbon from the lower face of the cylinder head using nonmetallic material to prevent scratching of the valve seat faces.
- Check the entire cylinder head for very fine cracks or damage invisible to ordinary sight using a hydraulic tester or a magnetic flaw detector.



#### 2) Distortion at the lower face

- Measure the amount of distortion using a straight edge and a feeler gauge at six positions as shown in the right figure.
- If the measured value exceeds the standard value, retrace the head with grinding paper of fine grain size to correct such defects.
- If the measured value exceeds the maximum allowable limit, replace the cylinder head.

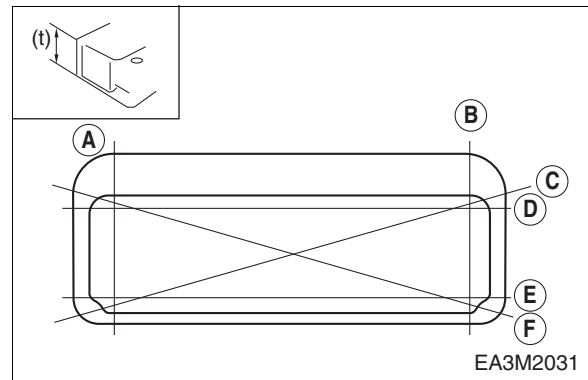

#### <Lower face warp and height>

	Standard	Limit
Warp	0.2 mm or less	0.3 mm
Thickness: t (reference)	109.9 ~ 110.1 mm	108.4 mm

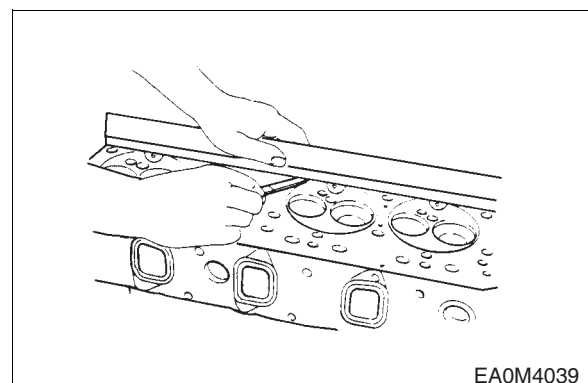

### 3) Flatness

Measure the flatness of the intake and exhaust manifold face mounted on the cylinder head using a straight edge and a feeler gauge.

Standard	Limit
0.05 mm	0.2 mm



### 4) Hydraulic test

Hydraulic test for the cylinder head is same as that for cylinder block.

## 6.2.3. Valve & Valve Guide

### 1) Valve

Clean the valves with clean diesel oil, then inspect them as follows:



#### • Valve stem outer diameter

Measure the valve stem outer diameter at 3 positions (top, middle, and bottom).

If the amount of wear is beyond the limit, replace the valve.

(mm)

Description	Dimension	Standard	Limit
Intake valve stem		ø8.95 ~ ø8.97	ø8.92
Exhaust valve stem		ø8.935 ~ ø8.955	ø8.895

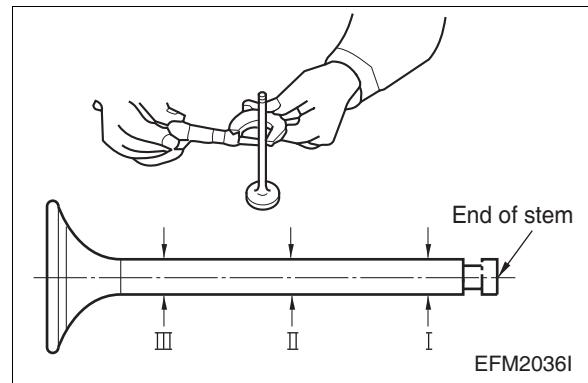

#### • Valve seat contacting faces

Check the valve seat contacting face for scratch or wear, and correct the faces with fine grinding paper as necessary. Replace if severely damaged.



#### • Valve head thickness

Measure the valve head thickness, and replace the valve if the measured value is beyond the limit.

(mm)

Description	Dimension	Standard	Limit
Intake valve		2.7	0.5 or less
Exhaust valve		2.2	0.5 or less

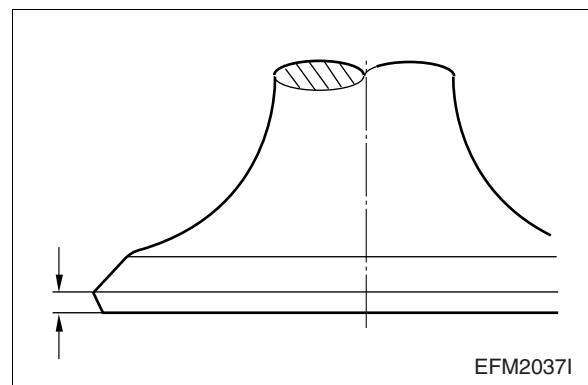

## 2) Valve guide

- Install the valve into the valve guide and measure the clearance between them by valve movement. If the clearance is excessive, measure the valve and replace either the valve or the valve guide, whichever worn more.



### <Valve stem end play>

	Standard	Limit
Intake valve	0.030 ~ 0.065 mm	0.1 mm
Exhaust valve	0.045 ~ 0.080 mm	0.15 mm

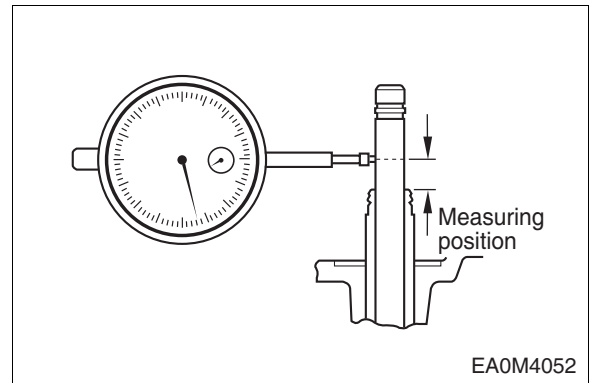

- Install the valve into the cylinder head valve guide, then check and see if it is centered with the valve seat using a special tool.



## 3) Valve seat



- Contacting face amount**

Measure the contacting face between the intake valve seat and exhaust valve seat for valve seat wear, and replace if the measured value exceeds the specified limit.

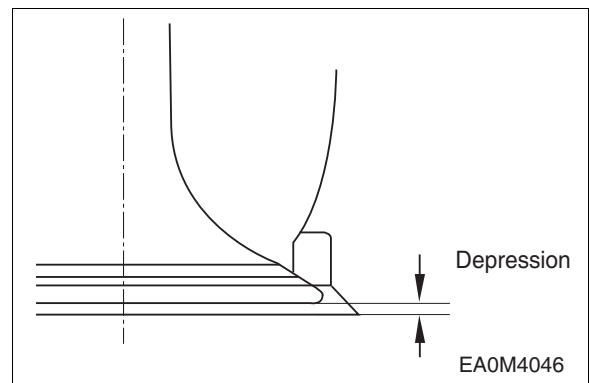

- Install the valve into the valve seat on the cylinder head, and check the amount of depression of the valve from the lower portion of the cylinder head using a dial gauge.

### <Valve Depression>

	Standard	Limit
Intake & Exhaust	0 ~ 0.3 mm	0.55 mm

If the amount of depression is beyond the specified limit, replace the valve seat.

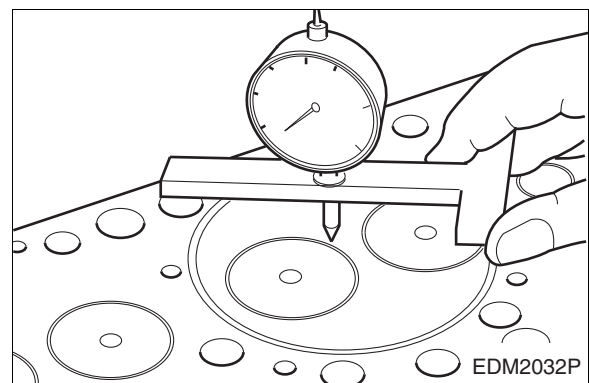



- For removal of the valve seat, apply arc welding work to two points of valve seat insert, and pull out the valve seat insert with inner extractor.

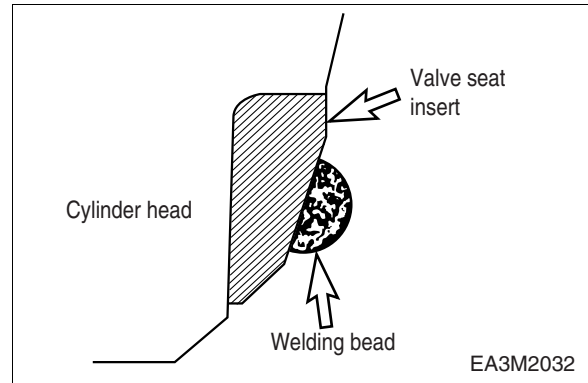

- For assembling of a new valve seat, by putting it among the dry ices of an ice box previously for about 2 hours for the cold shrinkage, and press it in the cylinder head by a special tool. (bench press)
- Apply the valve lapping compound on the valve head seating face and lap the valve seat by turning it until it is seated in its position, then wipe out the lapping compound.



**NOTE:** Clean the valve and cylinder head with light oil or equivalent after the valve seat finishing is completed, and make sure that there are no grinding materials remained.

#### 4) Valve spring



- **Visual check**  
Visually check the exterior of the valve springs for damage, and replace if necessary.



- **Valve spring free length**  
Use a vernier caliper to measure the valvespring free length. If the measured value is less than the specified limit, the valve spring must be replaced.

Spring free Length		Standard
Intake valve		64 mm
Exhaust valve	Inner	60 mm
	Outer	71 mm

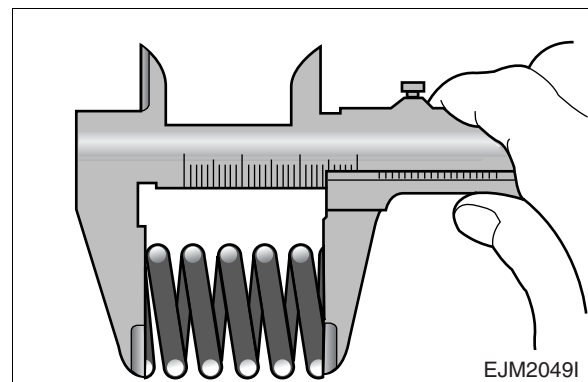



- **Valve spring inclination**

Use a surface plate and a square to measure the valve spring inclination. If the measured value exceeds the specified limit, the valve spring must be replaced.

	Standard	Limit
Valve spring inclination	1.8 mm	2.7 mm

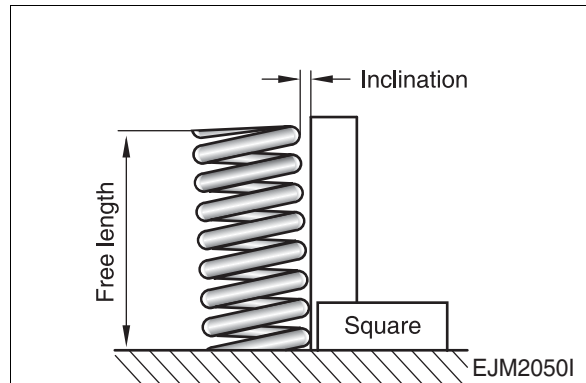

- **Valve spring tension**

Use a spring tester to measure the valve spring tension if the measured value is less than the specified limit, the valve spring must be replaced.

	Set Length	Spring force	Limit
Intake valve	Valve spring tension at 41 mm set length	70 kg	±3 kg
Exhaust valve	Inner 38 mm	28.6 kg	±6%
	Outer 41 mm	66 kg	±5%

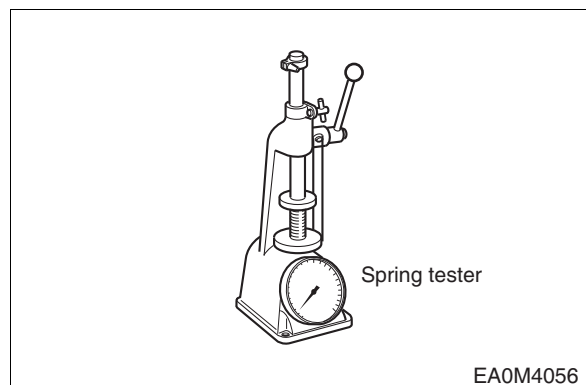

#### 6.2.4. Rocker Arm Shaft Assembly

##### 1) Rocker arm shaft



- **Rocker arm shaft run-out**

place the rocker arm shaft on two V blocks and inspect the shaft for bending using a dial gauge.

If the amount of this run-out is small, press the shaft with a bench press to correct the run-out. replace the shaft if the measured value exceeds the limit.

Limit	0.2 mm
-------	--------

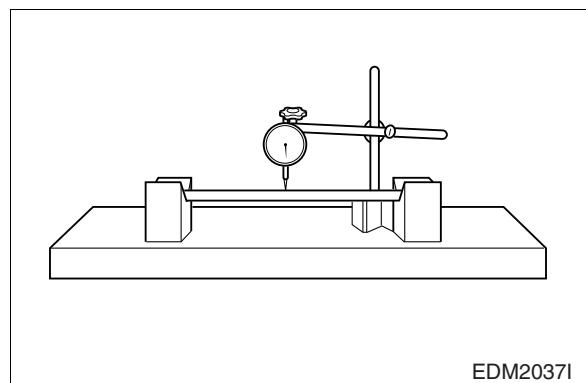



- **Rocker arm shaft diameter**

With an outside micrometer, measure the rocker arm shaft diameter at the point where the rocker arms have been installed.

Replace the rocker arm if the amount of wear is beyond the specified limit.

Standard	Limit
ø23.939 ~ ø23.96 mm	ø23.90 mm

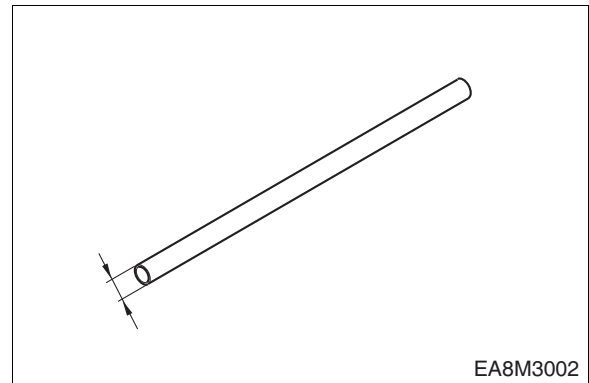

## 2) Rocker arm



- **Visual check**

Visually check the face of the rocker arm in contact with the valve stem end for scores and step wear. If the wear is small, correct it with an oil stone or grinding paper of fine grain size. Rocker arm with a considerable amount of step wear should be replaced.



- **Diameter of the rocker arm bushing**

Measure the inside diameter of the rocker arm bushing with an inside micrometer or vernier calipers, and compare the measured values with the rocker arm shaft diameter. If the clearance exceeds the limit, replace either bushing or shaft, whichever worn more.

Standard	Limit
0.040 ~ 0.113 mm	0.226 mm

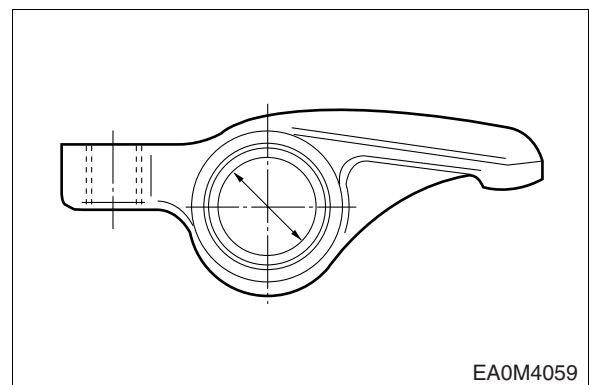

## 3) Tappet and push rod



- **Clearance**

Measure the clearance of the tappet and tappet holes of the cylinder block. If the value is beyond the specified limit, replace the tappet.

Standard	Limit
0.035 ~ 0.077 mm	0.15 mm



- **Visual check of tappet**

Visually check the face of the tappets in contact with the cam for pitting, scores or cracks, and replace if severely damaged. If the amount of cracks or pitting is small, correct with an oilstone or grinding paper.

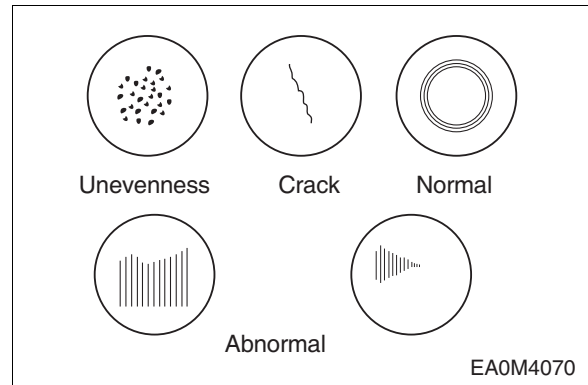

- **Outside diameter**

With an outside micrometer, measure the tappet outside diameter. If the measured value is beyond the limit, replace tappets.

<b>Standard</b>	$\varnothing 19.944 \sim$ $\varnothing 19.965 \text{ mm}$
-----------------	--

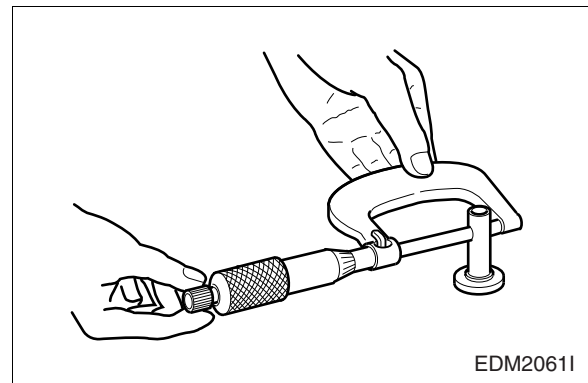

- **Push rod run-out**

Use a feeler gauge to measure the push rod run-out. Roll the push rod along a smooth flat surface as shown in the figure.

<b>Limit</b>	0.3 mm or less
--------------	----------------

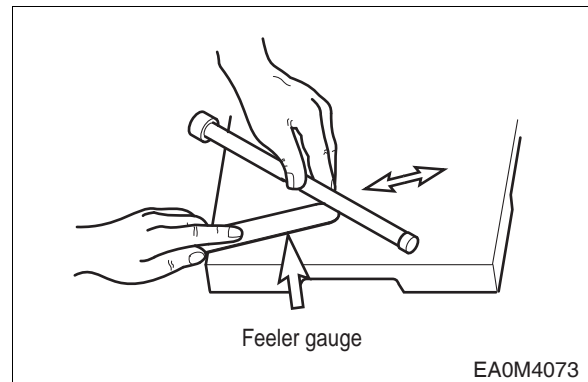

## 6.2.5. Camshaft

### 1) Cam



#### • Cam lobe height

Use a micrometer to measure the cam lobe height and journal diameter. If the measured number is less than the specified limit, the camshaft must be replaced.

(mm)

Items		Standard	Limit
Cam lobe height (C)	Intake	49.15	48.85
	Exhaust	49.32	49.00
Cam journal diameter (A, B)		57.86 ~ 57.88	57.52

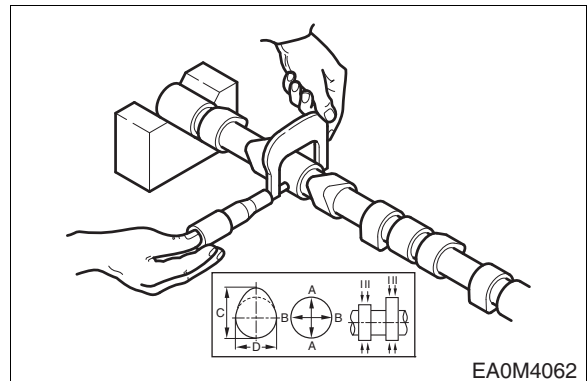

EA0M4062



#### • Cam surface

Inspect the cam surface for scratch or damage.

Slight step wear or damage on the cam surface may be corrected with an oilstone or oiled grinding paper. But, replace if severely damaged.

### 2) Camshaft



#### • Clearance between camshaft journal and camshaft bush

- With an outside -micrometer, measure the camshaft journal diameter.
- Measure the inside diameter of the camshaft bush on the cylinder block using a cylinder bore indicator, and compare the measured value with the camshaft outside diameter to determine the clearance.

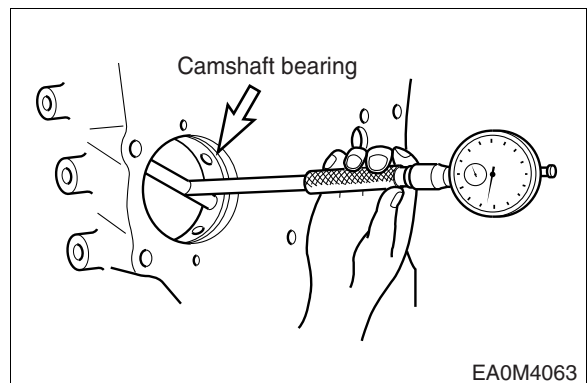

EA0M4063

#### <Clearance>

Standard	Limit
0.060 ~ 0.115 mm	0.230 mm

Replace the bush if the measured value is beyond the specified limit.



- **Run-out**

Support the camshaft on two V blocks and check for run-out using a dial indicator. Correct or replace the cam shaft if the amount of run-out is beyond the value indicating need for servicing.

Standard	Limit
0.05 mm	0.15 mm

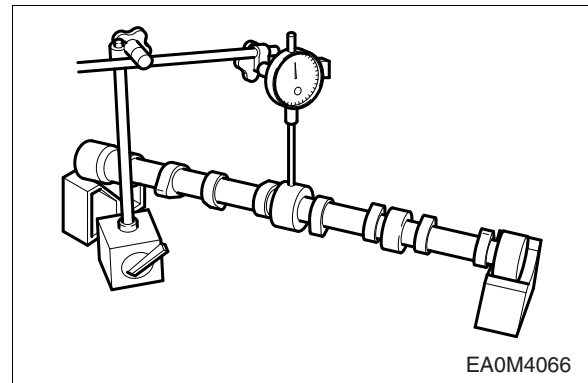

3) **Camshaft end play**



- Push the thrust plate toward the cam gear.
- With a feeler gauge, measure the clearance between the thrust plate and camshaft journal.
- If the end play is excessive, replace the thrust plate.

Standard	Limit
0.28 ~ 0.43 mm	0.5 mm

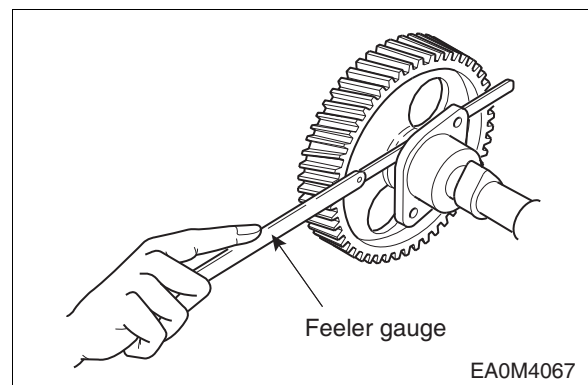

6.2.6. **Crank Shaft**

1) **Defect check**



- Visually check the crankshaft journal and crank pins for scores or cracks.
- Using a magnetic power and color check, inspect the crankshaft for cracks, and replace the crankshaft which has cracks.

2) **Wear measuring**



- With an outside micrometer measure the diameter of the crankshaft journals and pins in the directions as shown, and compare the measured values to determine the amount of wear.
- If the amount of wear is beyond the limit, polish the crankshaft and install undersize bearings. However, if the amount of wear is within the limit, you can correct the wear using an oil stone or oiled grinding paper of fine grain size. (Be sure to use grinding paper which has been immersed in oil.)

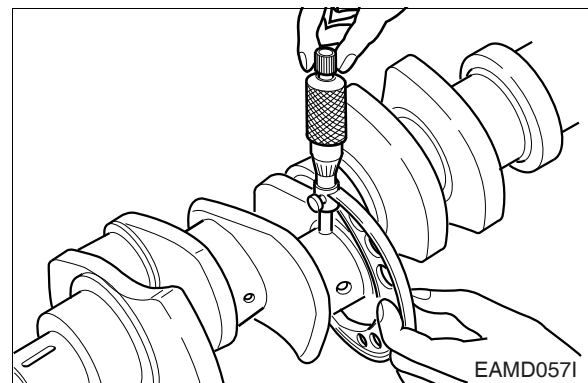

	Standard	Limit
Journal diameter	83.966 ~ 83.988	83.000 mm
Pin diameter	70.971 ~ 70.990	70.000 mm

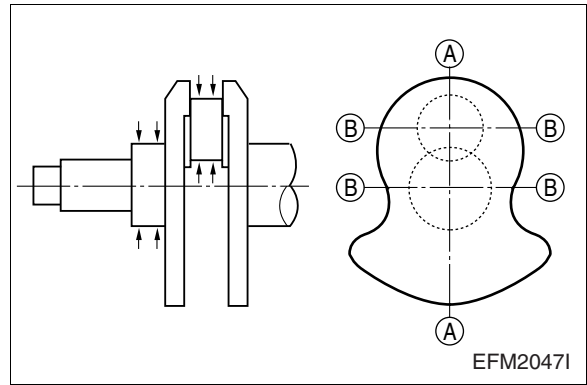

**\* Undersize bearings available**

- Standard
- 0.25 (Inside diameter is 0.25 mm lesser than the standard size.)
- 0.50 (Inside diameter is 0.50 mm lesser than the standard size.)
- 0.75 (Inside diameter is 0.75 mm lesser than the standard size.)
- 1.00 (Inside diameter is 1.00 mm lesser than the standard size.)

Undersize bearings are available in 4 different sizes as indicated above, and the crankshaft can be reground to the above sizes.



**NOTE:** When regrounding the crankshaft as described above, the fillet section 'R' should be finished correctly. Avoid sharp corners or insufficient fillet.

\* Standard values of 'R'

- ① Crank pin 'R' :  $4.5_{-0.2}^0$
- ② Crank journal 'R' :  $4_{-0.2}^0$

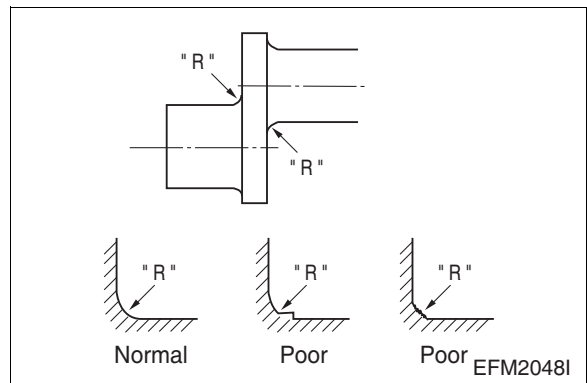

**3) Crankshaft run-out**

- Support the crankshaft on V blocks.
- Turn the crankshaft with a dial indicator placed on the surface plate and measure the



No.	Standard	Limit
4	0.10 mm	0.15 mm
3, 5	0.06 mm	0.10 mm
2, 6	0.03 mm	0.05 mm

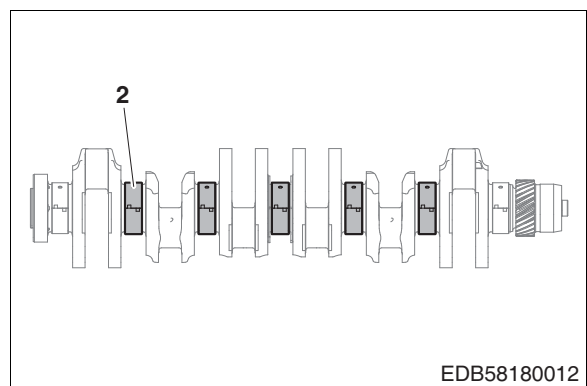

### 6.2.7. Crankshaft Bearing and Con- rod Bearing



#### 1) Visual check

Visually check the crankshaft bearing and the connecting rod bearing for scores, uneven wear or damage.

#### 2) Oil clearance between crankshaft and bearing.



#### • Main bearing clearance

Install the main bearing in the cylinder block, tighten the bearing cap to specified torque, then measure the inside diameter.



<b>Torque</b>	30 kg.m
---------------	---------

<b>Crank Journal Diameter</b>	83.966 ~ 83.988 mm
-------------------------------	--------------------

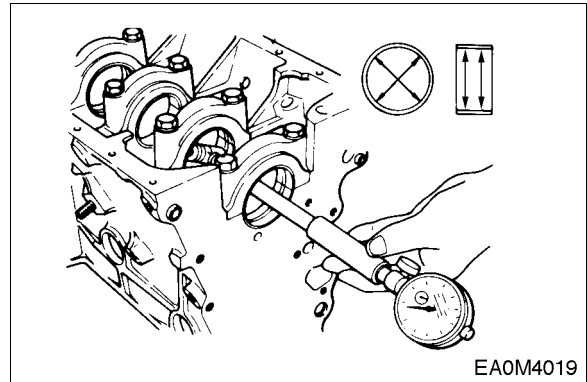

Compare the two values obtained through measurement of the main bearing inside diameter with the outside diameter of the crankshaft journal to determine the oil clearance.

Standard	Limit
0.052 ~ 0.122 mm	0.25 mm



#### • Connecting rod bearing clearance (Method 1)

Install the connecting rod bearing in the connecting rod bearing cap, tighten the connecting rod cap bolts to the specified torque, then measure the inside diameter.



#### <Connecting rod tightening torque>

Tightening Torque	1st Step	4 ±0.2 kg·m
	2ndStep	60° ±3°

**NOTE:** Do not apply oil to the joint before bolting.

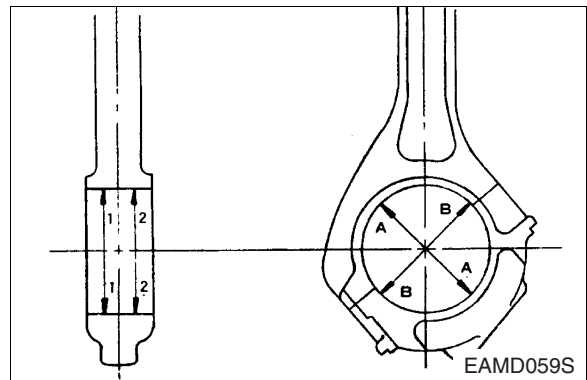

Compare the two values obtained through measurement of connecting rod bearing inside diameter with the outside diameters of the crankshaft pins to determine the oil clearance.

Standard	Limit
0.034 ~ 0.098 mm	0.25 mm



*If the clearance deviates from the specified range, polish the crankshaft journals and pins ground and install undersized bearings.*

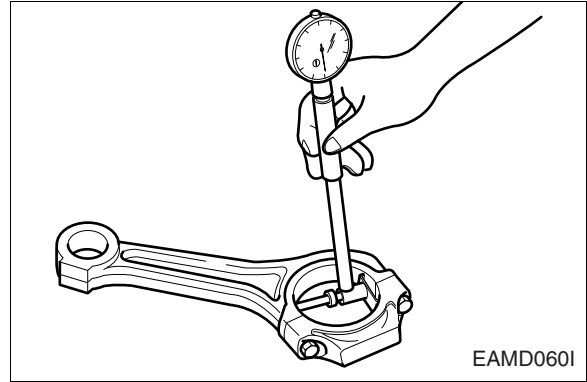

- **Connecting rod bearing clearance (Method 2: with plastic gauge)**

Assemble the crankshaft on the cylinder block and put the plastic gauge on the journal and pin of crankshaft and then after assembling bearing cap, tighten the bolts at the specific torque. Again after disassembling the bearing cap by removing the bolts, take out the flatted plastic gauge and measure the width of plastic gauge by means of plastic gauge measuring scale. This is the oil clearance.



### 3) Bearing spread and crush



- **Inspection**

Check to see that the bearing requires a considerable amount of finger pressure at re-assembly operation.

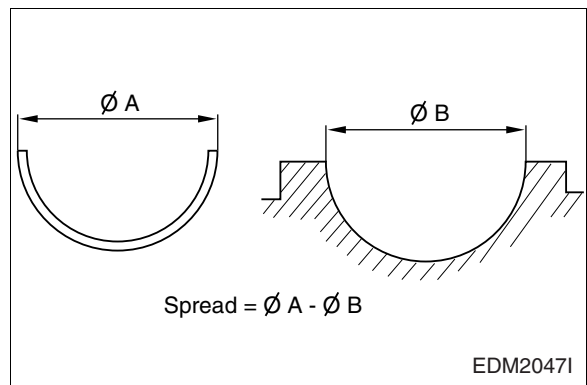
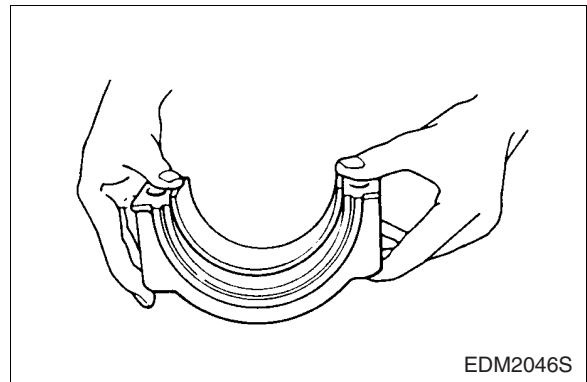



- **Crankshaft bearing crush**

Install the bearing and cap in the cylinder block, retighten the bolts to specified torque, only unscrew out one bolt completely, then measure the clearance between the bearing cap and cylinder block using a feeler gauge.

<b>Standard</b>	0.19 ~ 0.22 mm
-----------------	----------------

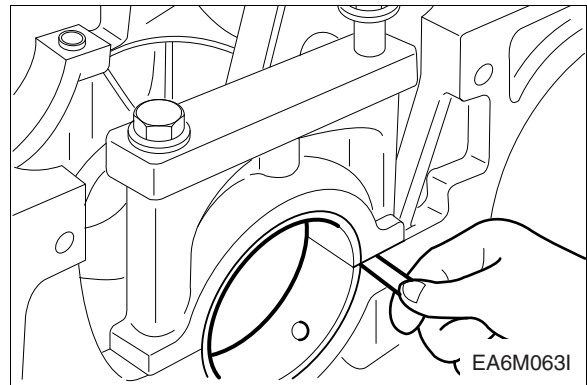

- **Connecting rod bearing crush**

Install the bearing and cap in the connecting rod big end, retighten the bolts to specified torque, only unscrew out one bolt completely, then measure the clearance between the bearing cap and the connecting rod big end using a feeler gauge.

<b>Standard</b>	0.08 ~ 0.14 mm
-----------------	----------------

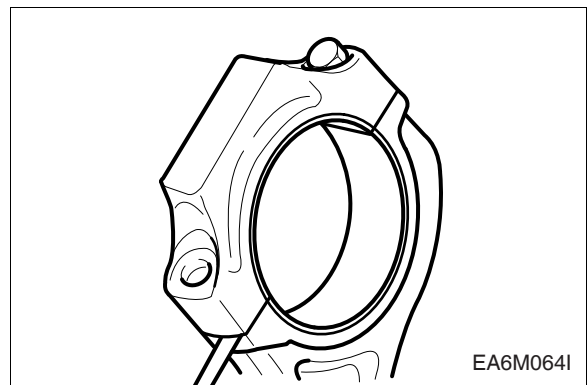

#### 4) Crank shaft end play

- Assemble the crankshaft to the cylinder block.



- With a dial gauge, measure crankshaft end play.

<b>Standard</b>	<b>Limit</b>
0.1 ~ 0.289 mm	0.5 mm

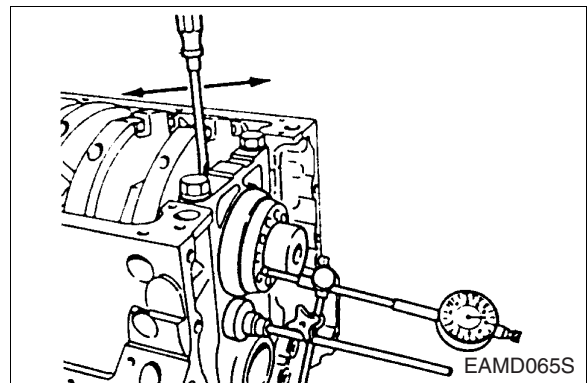

### 6.2.8. Piston



#### 1) Visual check

Visually check the pistons for cracks, scuff or wear, paying particular attention to the ring groove.

#### 2) Clearance between the piston and cylinder liner



- With an outside micrometer, measure the piston outside diameter at a point 13 mm away from the lower end of piston skirt at right angle against direction of the piston pin hole.

	Standard
Piston outside diameter	$\phi 110.883 \sim \phi 110.897 \text{ mm}$
Clearance between piston and liner	$0.103 \sim 0.139 \text{ mm}$

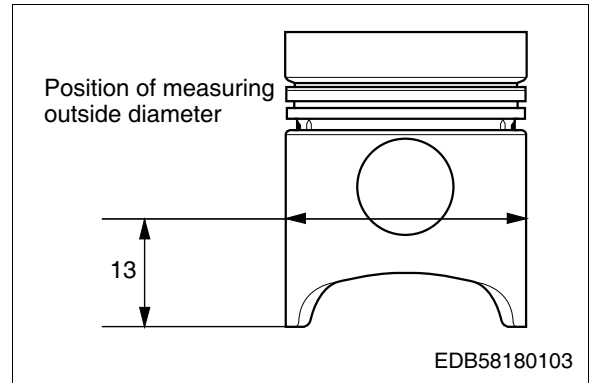

- Using a cylinder bore gauge, measure cylinder liner inside diameter at 3 points (Contacting face of the cylinder 1st, 2nd, and oil rings on B.D.C) in a direction at an angle of  $45^\circ$  separately. Take the mean value except the largest and smallest values.

Standard	Limit
$111 \sim 111.022 \text{ mm}$	$111.222 \text{ mm}$

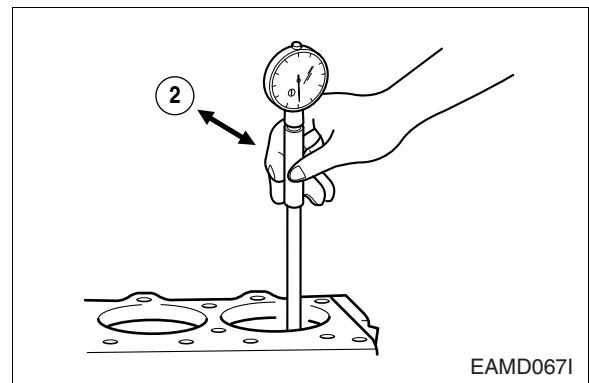

### 6.2.9. Piston Rings



#### 1) Visual check

Replace the piston rings with new ones if detected worn or broken when the engine is overhauled.

#### 2) Piston ring gap

- Insert the piston ring into the upper portion of the cylinder liner bore and then it should be positioned at a right angle against the cylinder liner wall surface.



- Measure the piston ring gap with a feeler gauge.

	Standard	Limit
Top ring	0.40 ~ 0.65 mm	1.5 mm
2nd ring	0.40 ~ 0.65 mm	1.5 mm
Oil ring	0.30 ~ 0.60 mm	1.5 mm



Replace piston rings with new ones if the gap is beyond the limit

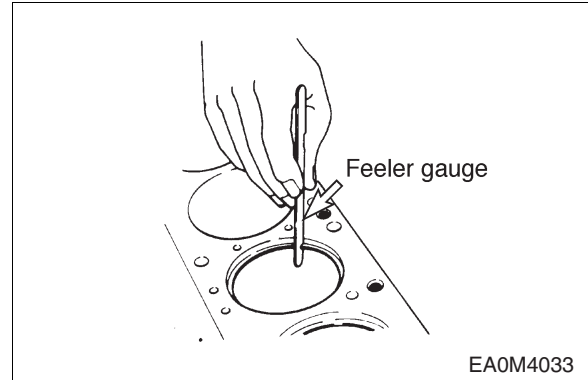

#### 3) Piston ring side clearance

- Fit the compression rings and oil ring in the piston ring grooves.
- With a feeler gauge, measure side clearance of each ring, and replace either the ring or piston if the measured value is beyond the specified limit.

	Standard	Limit
Top ring	0.105 ~ 0.155 mm	0.2 mm
2nd ring	0.07 ~ 0.102 mm	0.15 mm
Oil ring	0.05 ~ 0.09 mm	0.15 mm

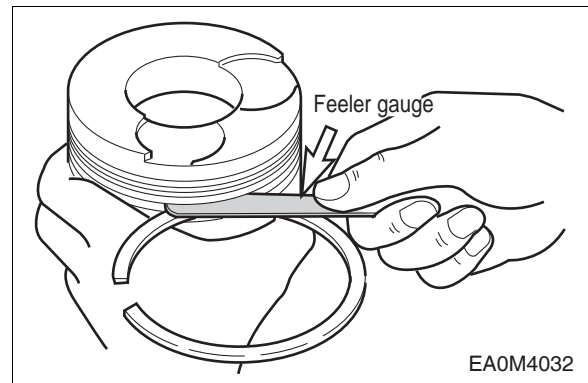

#### 4) Piston ring tension

With a tension tester, measure piston ring tension. Replace the piston ring if the measured value is beyond the limit.

	Standard
Top ring	2.58 ~ 3.88 kg
2nd ring	1.81 ~ 2.71 kg
Oil ring	3.57 ~ 5.03 kg

### 6.2.10. Piston Pin



#### 1) Wear

Measure the amount of wear on the piston pin at the points as shown. If the measured values are beyond the limit (0.005 mm or greater), replace the pin.

	Standard
Outside diameter	ø41.944 ~ ø42.0 mm

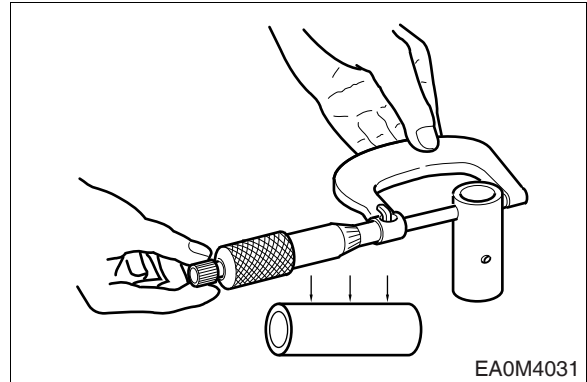

EA0M4031



#### 2) Clearance

Measure the clearance between the piston pin and connecting rod bush, and replace either of them, whichever damaged more, if the measured value is beyond the limit.

	Standard	Limit
Piston Pin (Piston)	0.003 ~ 0.015 mm	0.08 mm
Piston Pin (Connecting rod)	0.050 ~ 0.081 mm	0.15 mm

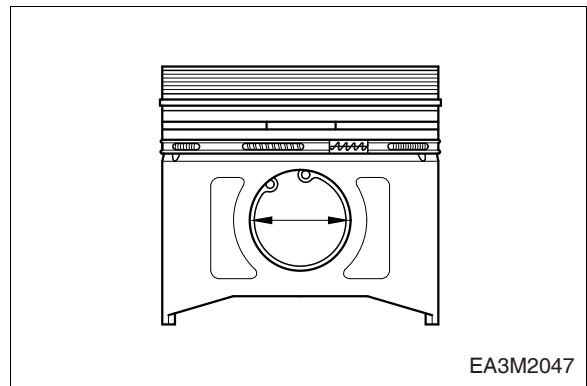

EA3M2047



#### 3) Condition check

Check the insertion condition of the piston and piston pin. If it is possible to force the pin into the piston heated by piston heater, the piston is normal.



*When replacing the piston, be sure to replace the piston pin together.*

### 6.2.11. Connecting Rod



#### 1) Distortion

Check the connecting rod for distortion. As shown in the figure below, install the connecting rod to the connecting rod tester, and check for distortion using a feeler gauge. If the connecting rod is found distorted, never re-use it but replace with a new one.



#### 2) Holes alignment (parallelism)

Measure the alignment of the connecting rod small bushing hole and the connecting rod big end hole. At this time also, use both connecting rod tester and feeler gauge.

Standard	Limit
0.05 mm	0.1 mm or less

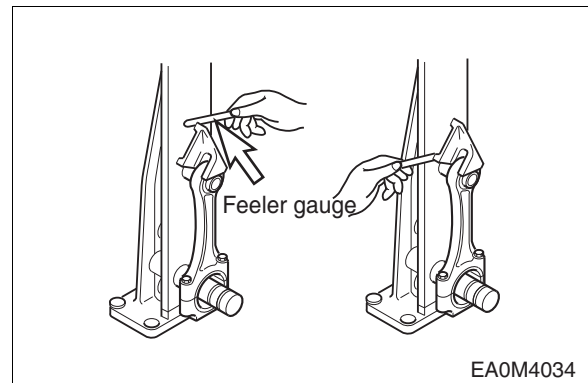

#### 3) Wear

- Assemble the connecting rod to the crankshaft and measure connecting rod big end side clearance using a feeler gauge.
- Assemble the connecting rod to the piston and measure connecting rod small end side clearance.
- If the measured values are beyond the limit, replace the connecting rod.

Limit	0.5 mm
-------	--------

## 6.3. Engine Re-assembly

### 6.3.1. General Precautions

- Clean all the disassembled parts, particularly oil and water ports, using compressed air, then check that they are free from restrictions.
- Arrange the general and special tools in order to engine assembly operation.
- To lubricate each sliding part, prepare the clean engine oil.
- Prepare maintenance materials such as sealant, gaskets, and etc.
- Discard used gaskets, seal rings, and consumable parts, and replace with new ones.
- Apply only the specified torque for bolts in the specified tightening order and avoid overtightening.
- Be sure to check that all the engine parts operate smoothly after being reassembled.
- Check the bolts for looseness after preliminary re-assembly.
- After completing the engine re-assembly operation, check if there is missing parts or shortage of parts.
- Keep your hands clean during the maintenance.

### 6.3.2. Cylinder Block

- Cover the floor of the workshop with wood plate or thick paper to prevent damage to the cylinder head and place the head face of the cylinder block towards downward.

### 6.3.3. Oil Spray Nozzle



- Tighten and assemble the oil spray nozzle with fixing bolts using the spray nozzle jig.

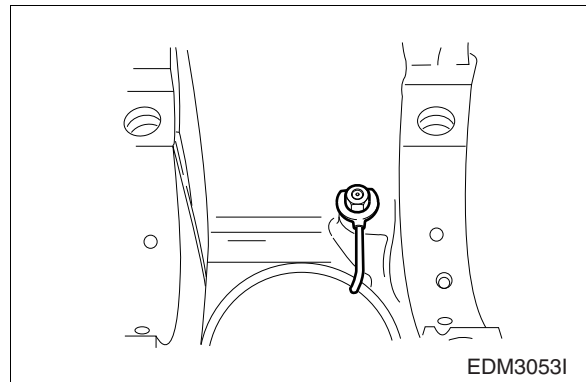

### 6.3.4. Tappet and Cam Shaft



- Under cool a new bush with dry ice for about 2 hours and press it into position in the cylinder block using a bench press. After the pressing operation, measure the inside diameter of the cam bush to check if it is not deformed.



- Apply engine oil to the entire face of the tappets and slide them into the tappet holes on the cylinder block.

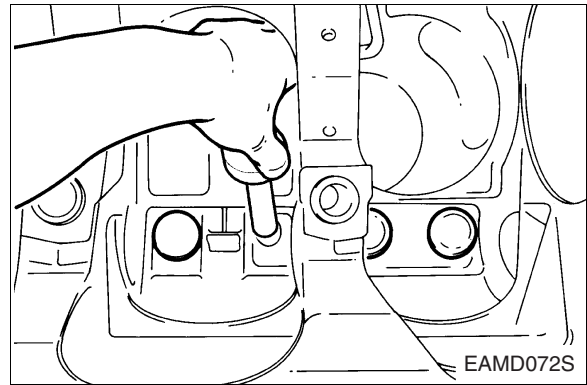

- Wet the cam bush inside diameter and camshaft with oil, and carefully assemble them while turning the camshaft.



- Check to see that the camshaft rotates smoothly.

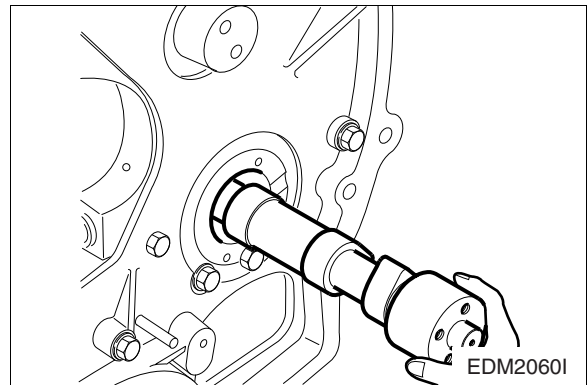

### 6.3.5. Crankshaft



- Install the main bearing machined with two holes in the cylinder block so that the key is aligned with the key groove, then apply oil to the bearing surface.

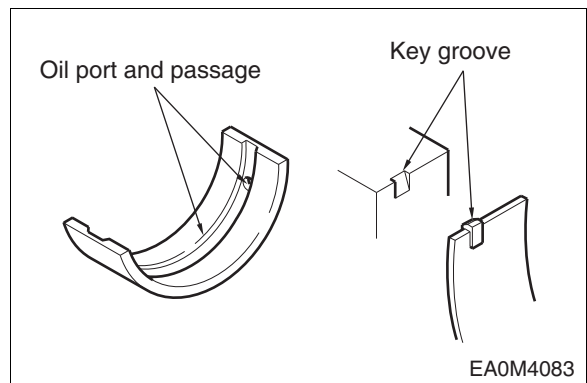

- Heat the crankshaft gear for at least 10 minutes to 120°C then apply sealant (Loctite # 641)' to the inside wall of the heated crankshaft gear evenly before inserting it to the end of crankshaft.

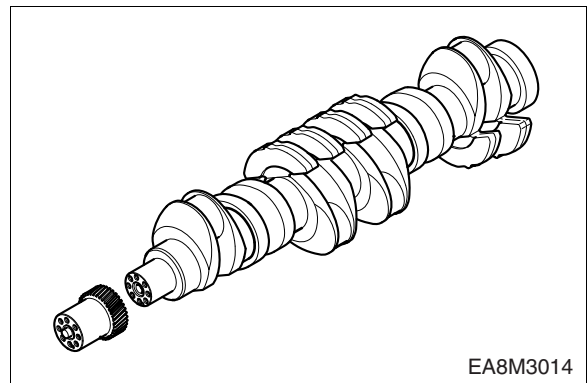



- Semi-tighten a bolt at both sides of the crankshaft, apply engine oil to journals and pins, then assemble the crankshaft with the cylinder block by tightening the fixing bolts.

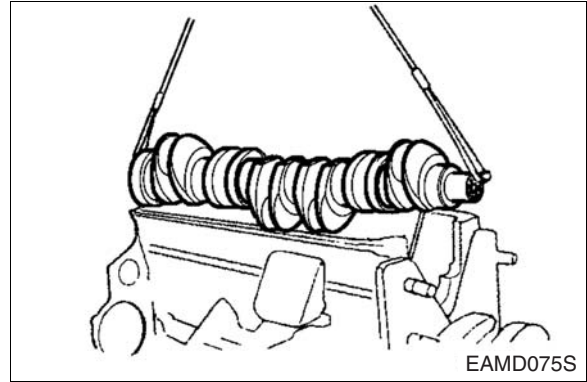

- Install the oiled thrust washers with the oil groove facing outward of the bearing.

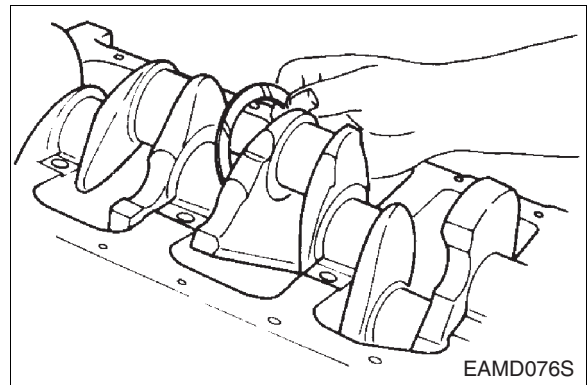

- Install the bearing and thrust washers to the bearing cap and apply oil to the bearing and thrust washers.

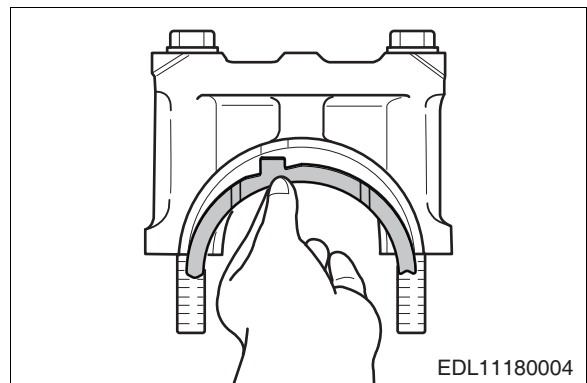

- Install the bearing cap by matching the cylinder block number compare with the bearing cap number.

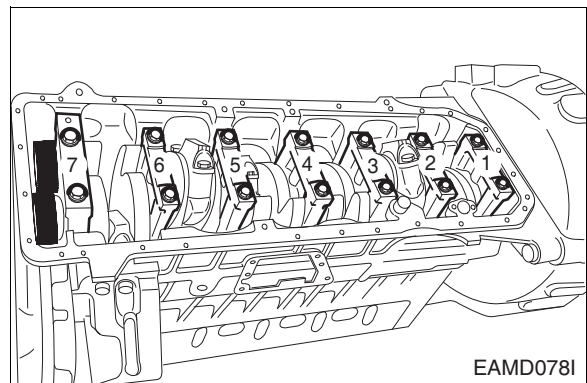



- Tighten the bearing cap bolts in tightening sequence to specified torque.



<b>Torque</b>	30 kg·m
---------------	---------

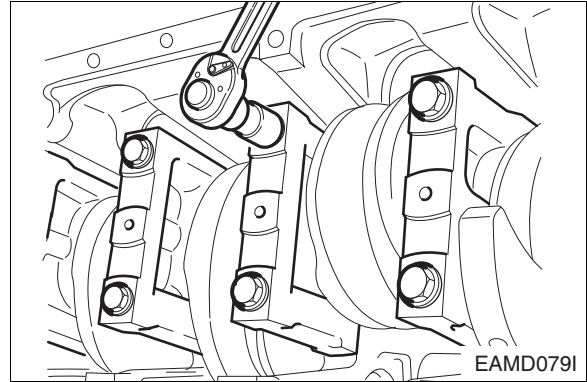

- After semi-tightening both bolts evenly, tighten them diagonally specified torque using a torque wrench as follows.

**<Tightening order>**

- 1) First stage : Temporary assemble the bolts about 1 ~ 2 threads
  - 2) Second stage : With impact wrench, tighten up to about 15 kg·m
  - 3) Third stage : With torque wrench, tighten up to about 25 kg·m
  - 4) Fourth stage : By means of torque wrench, tighten finally in the specified torque. (30 kg·m).
- Tighten the bearing cap in the sequence of it's number 4-3-5-2-6-1-7.



- Check to see that the assembled crankshaft turns smoothly.

### 6.3.6. Flywheel Housing

- Temporarily install the guide bar on the cylinder block.
- Apply gasket to the cylinder block.



- Using the dowel pin and guide bar, install the flywheel housing and tighten the fixing bolts in a diagonal sequence to specified torque.

<b>Torque</b>	11.2 ±1.12 kg·m
---------------	-----------------

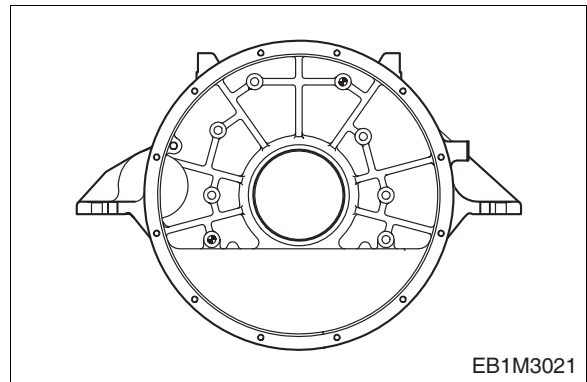

### 6.3.7. Rear Oil Seal



- Apply lubricating oil to the outside of the oil seal and flywheel housing inside diameter and fit them over the crank shaft, then assemble the oil seal using an oil seal fitting jig.

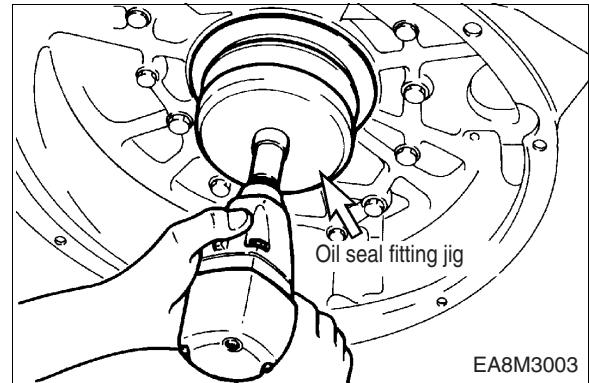

### 6.3.8. Flywheel



- Install a guide bar into a bolt hole on the crank shaft, and lift the flywheel to align the dowel pin with the pin hole on the flywheel for temporary assembly operation.

- Install bolts in the remaining holes, take out the guide bar, then install a bolt in the hole where the guide bar had been inserted.



- Tighten the fixing bolts using a torque wrench in a diagonal sequence to specified torque.

<b>Torque</b>	18 ±3.6 kg·m
---------------	--------------

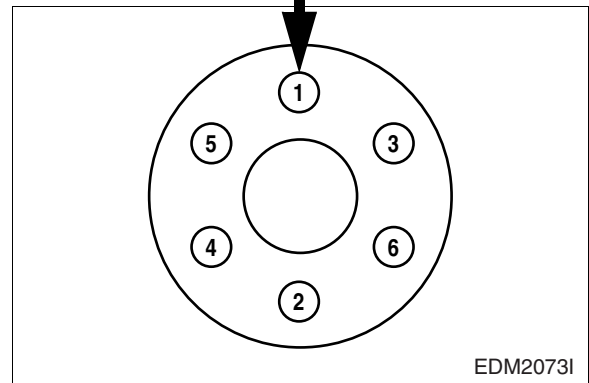
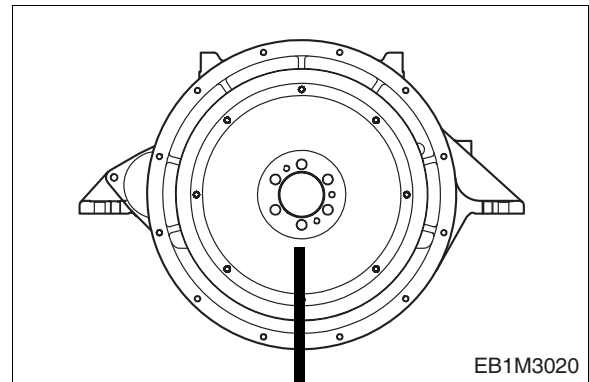

### 6.3.9. Timing Gear Case



- Mount the gasket using dowel pin on the cylinder block.
- Install the timing gear case by aligning the dowel pin with the dowel pin hole on the timing gear case.

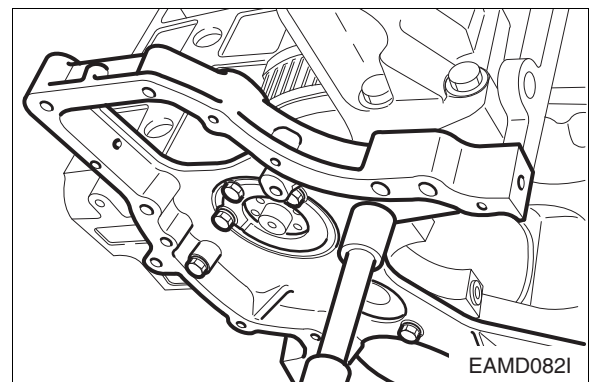

### 6.3.10. Injection Pump Drive Gear

- Mount the gasket by aligning the bolt holes with the pin holes on the bearing housing.
- Tighten up the fixing bolts in the direction of fuel injection pump.

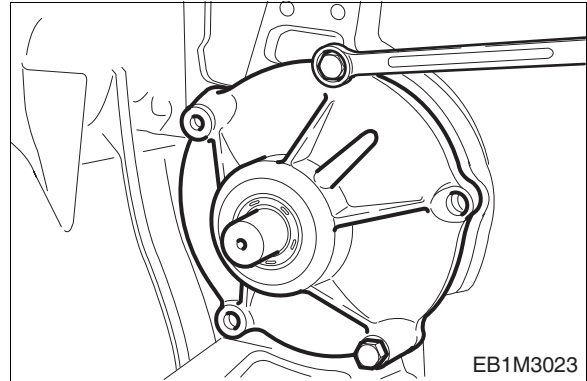

### 6.3.11. Timing Gear

- Install the oil pump idle gear into the No.7 bearing cap.
- Install a thrust washer over the camshaft and assemble the cam gear by aligning it with camshaft key groove.



<b>Torque</b>	2.2 kg-m
---------------	----------

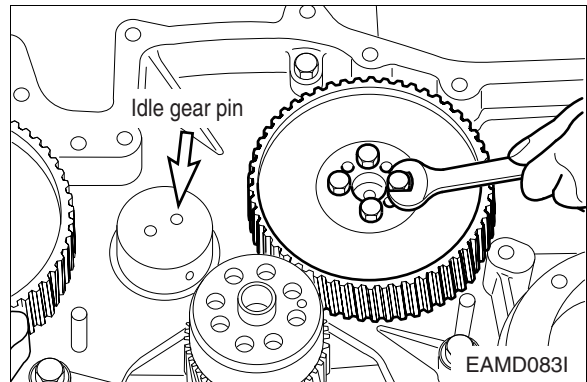

- After the oil port on the idle gear pin towards the cylinder block, install the idle gear pin.

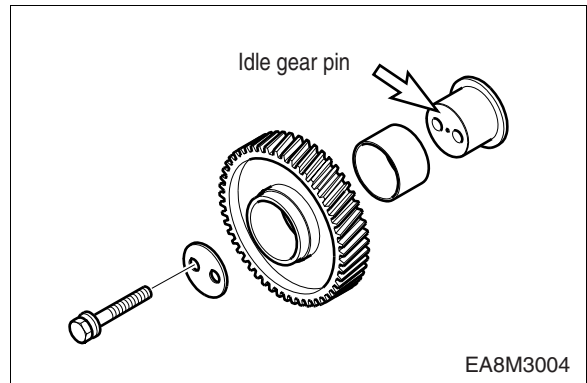

- Install the idle gear by coinciding the marks impressed on the crank gear, cam gear, fuel injection pump drive gear, and idle gear each other.



- Install a thrust washer on the idle gear and tighten to specified torque.

<b>Torque</b>	3.8 kg-m
---------------	----------

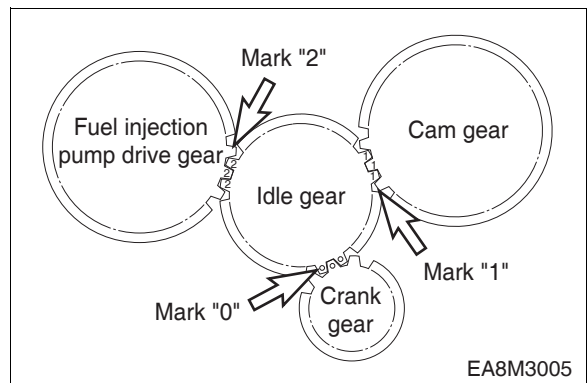



- Check and adjust the amount of backlash between gears using a feeler gauge.

Items	Standard	Limit
Cam gear & idle gear	0.16 ~ 0.28 mm	0.35 mm
Crank gear & idle gear	0.16 ~ 0.28 mm	0.35 mm
Injection pump & idle gear	0.16 ~ 0.28 mm	0.35 mm

### 6.3.12. Timing Gear Case Cover

- Install the dowel pin on the timing gear case.
- Mount a gasket by aligning the fixing bolt holes with those on the gasket.
- Align the dowel pin with the cover pin hole, then install the cover with light tap.
- Tighten the fixing bolts beginning with the oil pan fitting face.

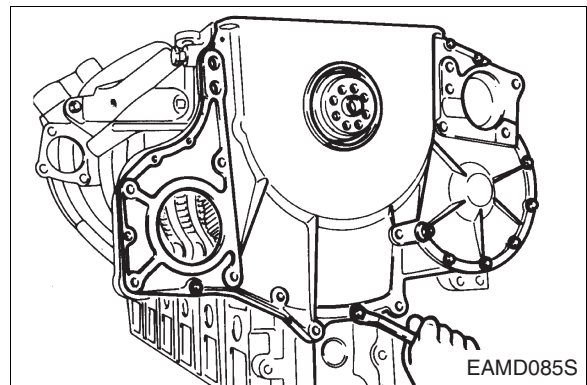

### 6.3.13. Front Oil Seal



- Apply lubricating oil to the outside of the oil seal and timing gear case inside diameter and fit it over the crankshaft, then assemble the oil seal using an oil seal fitting jig.

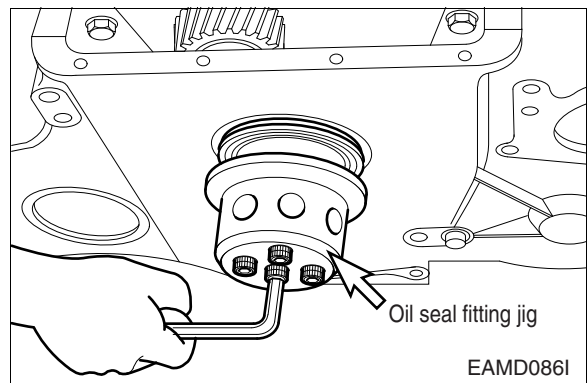

### 6.3.14. Cylinder Liner

- Stand the cylinder block so that the flywheel faces downward.
- Thoroughly clean the liner flange fitting surface and bore inside with compressed air to prevent the entry of foreign substances.
- After the cleaning operation, make the cylinder liner dried up and push it into the cylinder block by hand.



- Wet the liner inside diameter with engine oil.

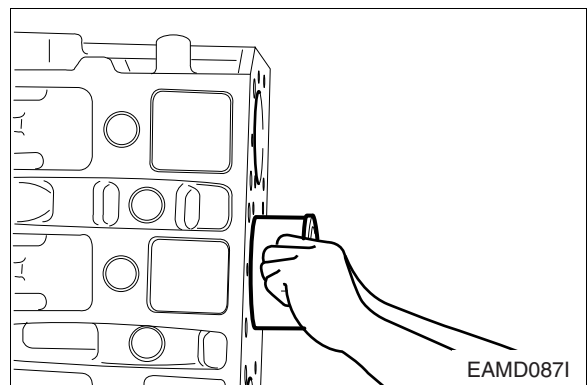

### 6.3.15. Piston and Connecting Rod



- Use a piston heater to heat the piston approximately 100°C ~ 212°F for 5 minutes.

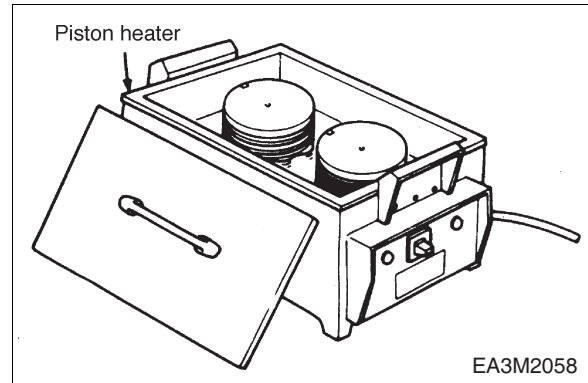

- Align the piston pin hole with the connecting rod small end bush oiled and press the piston pin (by lightly tapping with a rubber hammer) to assemble the connecting rod into the piston.

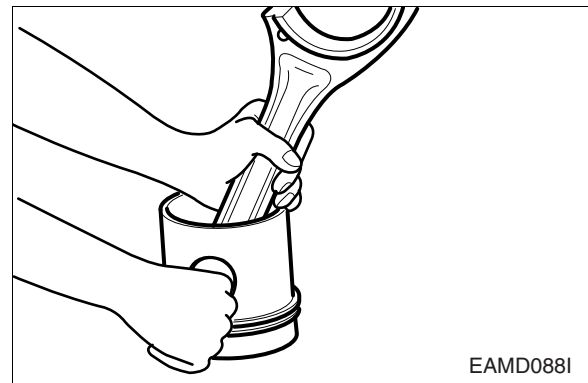

- Nothing the direction of the piston, make the longer side (machined with key groove on the bearing) of the connecting rod big end.
- On the piston head surface, the longer side connecting rod big end is in opposite direction from the valve seating surface as well as in the same direction with the narrow margin of the combustion chamber.

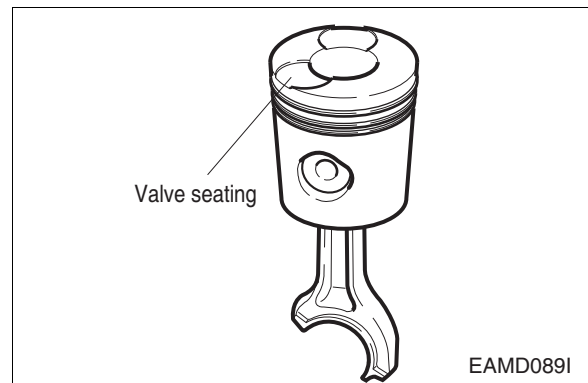

- Install the snap rings and check to see that it is securely assembled.



- Install the piston ring in the piston using piston ring pliers.



- Identify the mark "Y" on the piston ring end to prevent assembling the bottom of the piston ring is being interchanged with its top faced marked "Y".



**NOTE:** Be sure to make the piston ring end marked face ("Y") upward.

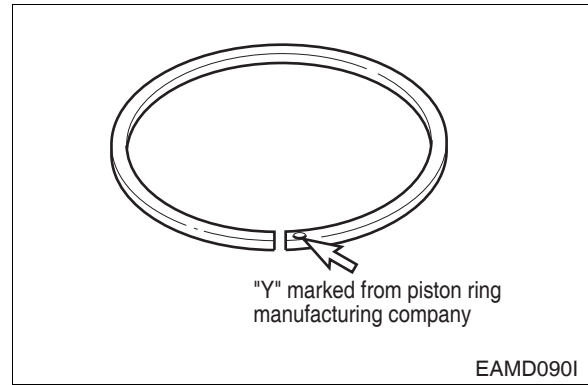

- Adjust the angle among individual piston ring gaps to 90° and fit a piston assembling jig onto the piston, Use care not to match the ring gaps with the piston pin direction.



- Install the bearing by aligning it with the connecting rod key groove and apply oil to the bearing and piston.

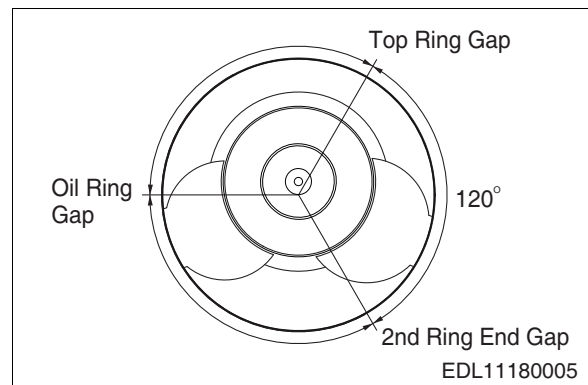

- Make a position the valve seating surface toward the tappet hole and insert the piston with hand. Use care not to damage the cylinder liner and piston, and slightly lift and insert the piston into the cylinder so that the ring may not be damaged by the fillet of the liner.



- Install the bearing in the connecting rod cap and apply oil.

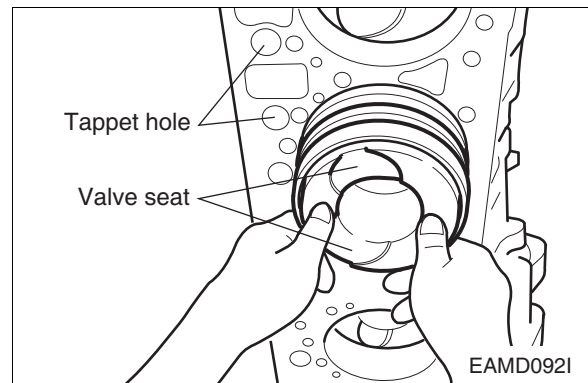

- Make sure that the manufacture serial number impressed on the connecting rod cap and the connecting rod big end is identical, and install the connecting rod cap by aligning it with dowel pin.



- **Semi-tighten the fixing bolts by hand, tighten them to specified torque using a torque wrench as follows.**

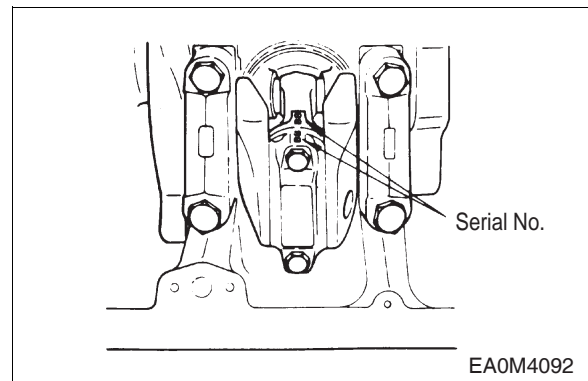

### <Tightening order>

- 1) First stage : Temporary screw the bolt about 1 ~ 2 threads
- 2) Second stage : With torque wrench, tighten at about 10 kg·m
- 3) Third stage : With torque wrench, tighten up to about 15 kg·m
- 4) Fourth stage : Finally, tighten in the specified torque 18 kg·m with torque wrench.

### <Connecting rod tightening torque>

<b>Tightening Torque</b>	1st Step	4 ±0.2 kg·m
	2nd Step	60° ±3°

**NOTE:** Do not apply oil to the joint before bolting.



- Move the bearing cap with hand, and release and reassemble it if no movement is detected.

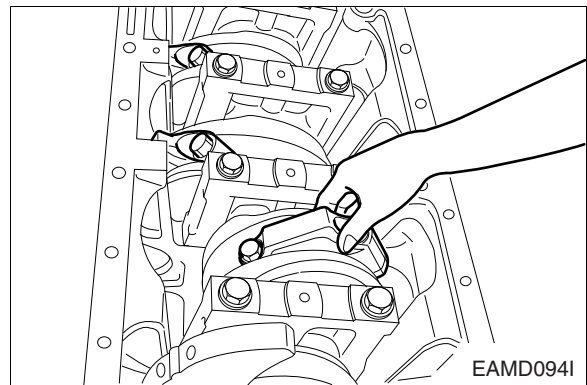

### 6.3.16. Relief Valve

- Assemble the relief valve.

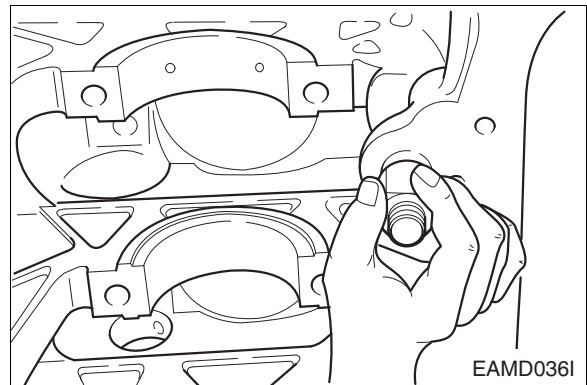

### 6.3.17. Oil Pump and Oil Pipe



- Install a dowel pin in the No.7 bearing cap, then assemble the oil pump with specified torque.

<b>Torque</b>	4.4 kg·m
---------------	----------

- Assemble the oil suction pipe with the delivery pipe, then install the bracket on the bearing cap.

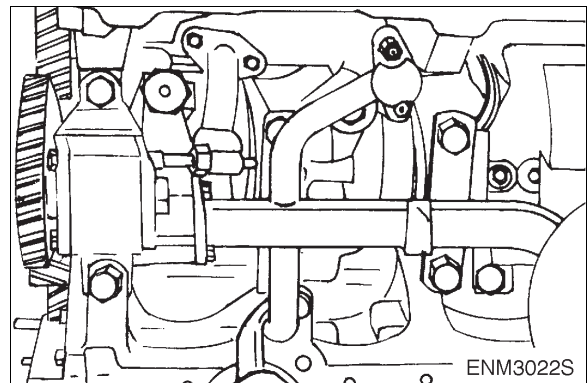

### 6.3.18. Oil Pan

- Mount gasket and put the oil pan thereon.
- Align the bolt holes with gasket holes to prevent damage to the gasket and tighten bolts to specified torque.



<b>Torque</b>	2.2 kg·m
---------------	----------

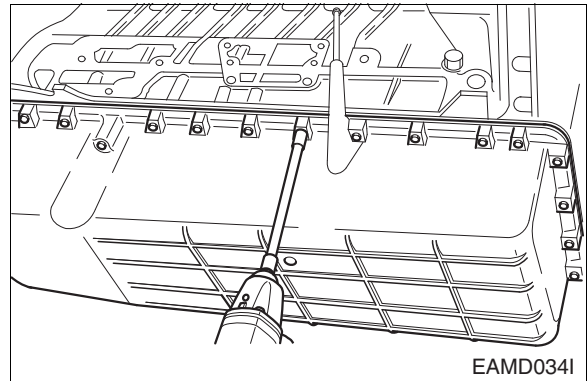

### 6.3.19. Vibration Damper and Pulley

- Assemble the vibration damper on the Crankshaft pulley.
- Install the crankshaft pulley assembly on the crankshaft, then tighten the bolts and thrust washers.



<b>Torque</b>	13.4 kg·m
---------------	-----------

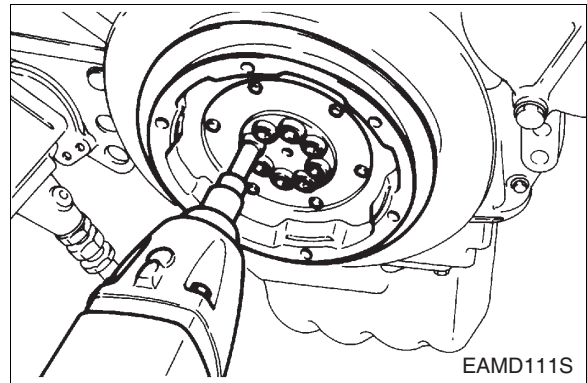

### 6.3.20. Cylinder Head

- Install the injection nozzle fixing stud bolts and water pipe fixing stud bolts.
- Clean the head bolt holes on the cylinder block with compressed air to remove foreign substances and thoroughly clean the gasket fitting face of the cylinder block.
- Install head gasket, with 'TOP' mark facing upward, on the cylinder block by aligning the holes with dowel pins.

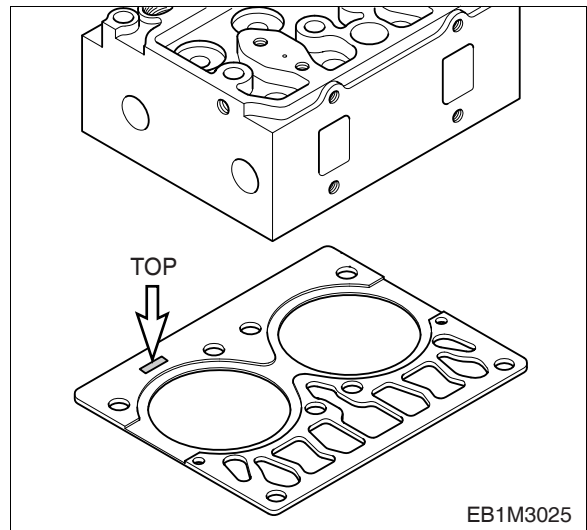



- Check the inside of combustion chamber for foreign substances, and carefully mount the cylinder head on the cylinder block by aligning the dowel pin in the pin hole. Be careful not to damage the head gasket. If the dowel pin is not in alignment, lift the cylinder head again and then remount it.

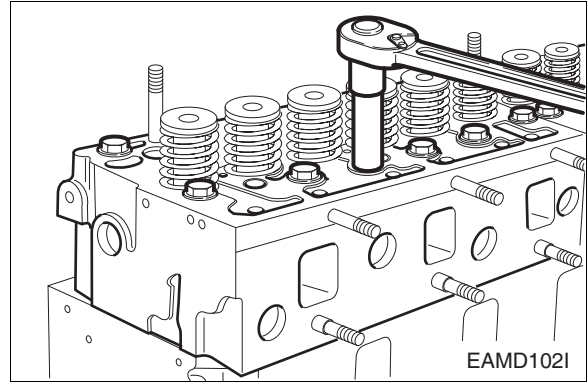

- **Tighten the head bolts in proper sequence to the specified torque according to bolt tightening order. (refer to the figure)**

**<Cylinder head bolts>**

	<b>Type 5 (10.9T)</b>
Specification	 <b>COLLARD DUO BOLT</b> M14 x 1.5 x 150
Torque	6 kg·m + 90° + 90° + 90° + 60°

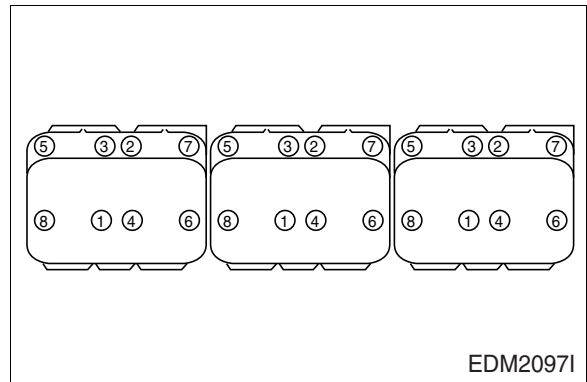

However, before tightening bolts, align the side face of 3 cylinder heads with parallel. They should be adjusted in a straight line exactly.

**<Tightening order of bolts by steps>**

- 1) First stage : Coat the bolts with engine oil.
- 2) Second stage : Tighten 1 ~ 2 threads with hands.
- 3) Third stage : Tighten at about 6 kg·m with a wrench.
- 4) Fourth stage : Tighten at rotating angle 90° with a wrench.
- 5) Fifth stage : Tighten at rotating angle 90° with a wrench.
- 6) Sixth stage : Tighten at rotating angle 90° with a wrench.
- 7) Seventh stage : Finally, tighten at rotating angle method 60° with a torque wrench.

However, all bolts are tightened simultaneously by above steps as possible.



- Coat the push rod with engine oil and insert it into the push rod hole.

### 6.3.21. Intake and Exhaust Valves



- Identify the marks of "IN" and "EX" impressed on the valve head before assembling the valve in the head.



- With a valve stem seal fitting jig, assemble the valve guide and stem seal.

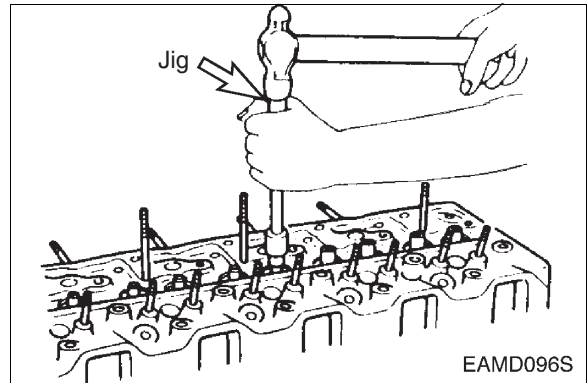

- After installing valve springs and spring retainer, press the retainer with a jig, then install cotter pin.



- Tap the valve stem lightly with a rubber hammer to check that the valve is assembled correctly.

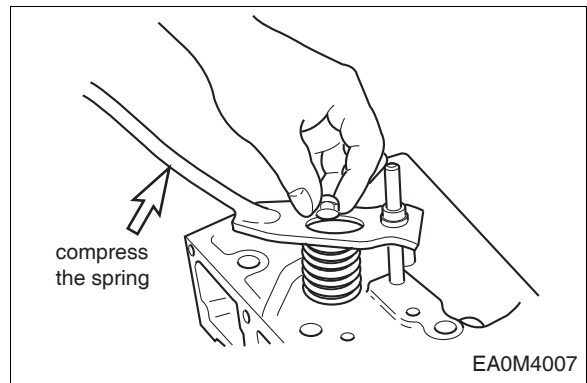

### 6.3.22. Rocker Arm Assembly



- Apply lubricating oil to the rocker arm bush and shaft, and assemble the intermediate bracket with the rocker arm using fixing bolts.



<b>Torque</b>	4.4 kg·m
---------------	----------

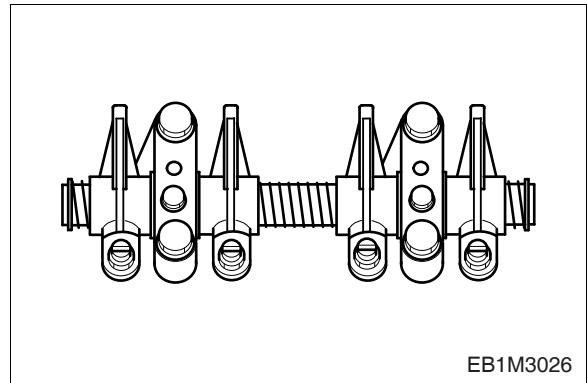

- Semi-install the valve clearance adjusting bolts onto the rocker arm.
- Install the spring, rocker arm, bracket, rocker arm, spring, washer, and snap ring in the described sequence.
- Install the rocker arm and bracket in the same direction.

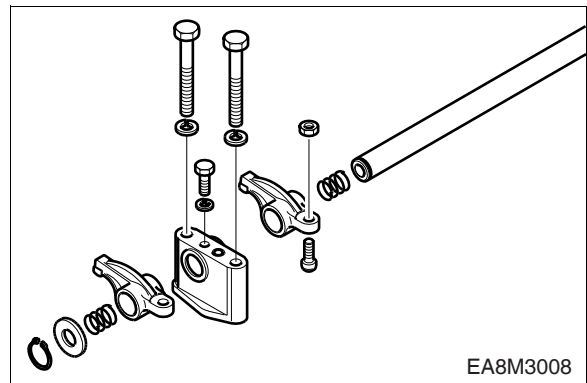

### 6.3.23. Injection Nozzle



- Install the dust seal with its round portion facing downward.
- Mount a seal ring on its position of the cylinder head and then assemble the nozzle holder.



- Be sure to follow the specified torque.

<b>Torque</b>	7.0 kg·m
---------------	----------

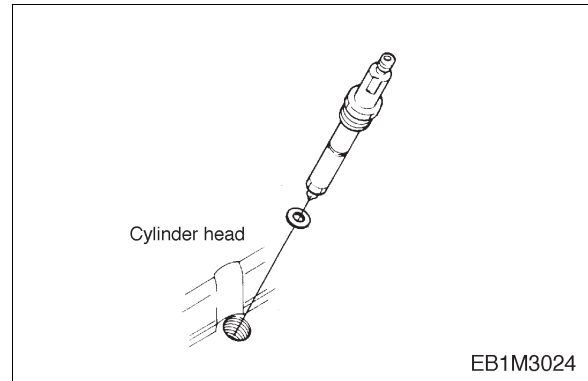

### 6.3.24. Valve Clearance Adjustment

- Cylinder No. 1 begins from the rear side where the flywheel is mounted but cylinder No. 6 begins from the front side of the engine on the contrary.

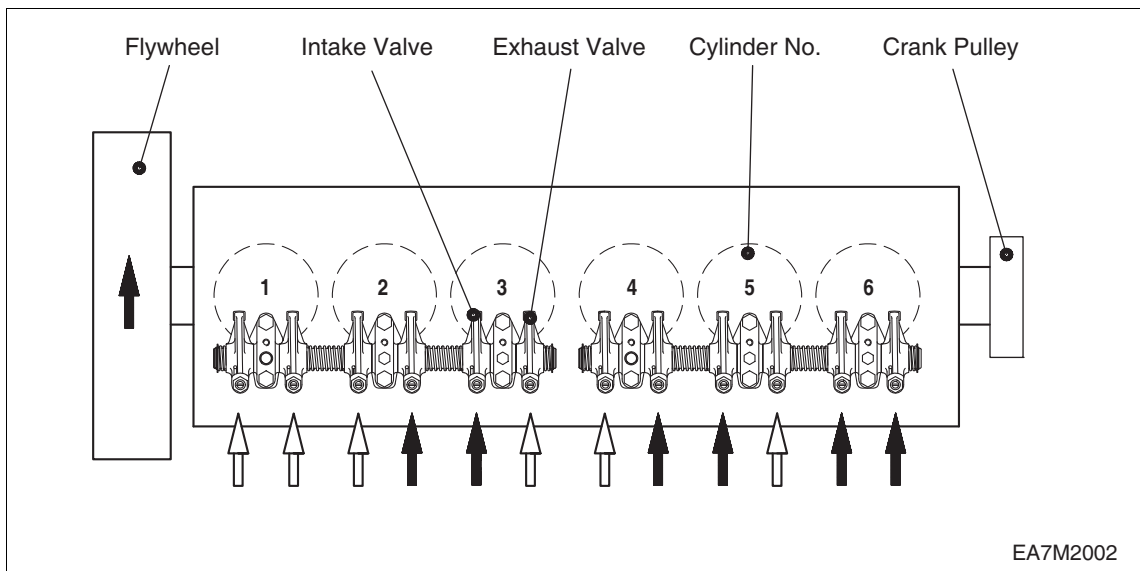

#### Step 1:



- After letting the cylinder No.6 in the overlap TDC position by turning the crankshaft, adjust the valves corresponding to "↑" of following figure. At this time cylinder No. 1 should be at the ignition TDC position.

#### Step 2:

- After adjusting upper valves turn the crank pulley 360° to adjust the other valve clearance until the cylinder No. 1 comes to overlap TDC position. At this time cylinder No. 6 should be at the ignition TDC position(O.T).
- Adjust the valve corresponding to "↑" of upper figure. After reconfirming the valve clearances, retighten it if necessary.



- Loosen the lock nuts of the rocker arm adjusting screws and push the specified feeler gauge and adjusting the valve clearance with adjusting screw respectively.

Specified value	
Intake valve	Exhaust valve
0.3 mm	0.3 mm



- Adjust valve clearance with a feeler gauge and tighten the fixing nuts to specified torque.

<b>Torque</b>	4.4 ±0.45 kg·m
---------------	----------------

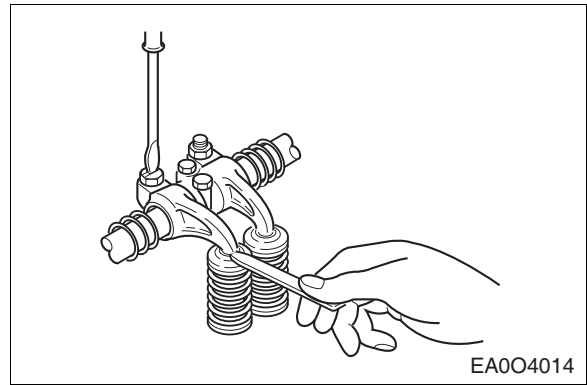

### 6.3.25. Injection Pipe



- Semi-assemble the nuts at both ends of the fuel injection pipe and tighten them up one by one to specified torque.

<b>Torque</b>	2.9 ~ 3.2 kg·m
---------------	----------------

- Tighten the hollow screws to assemble the fuel return pipe.
- Assemble the fuel return hose on the fuel injection pump.

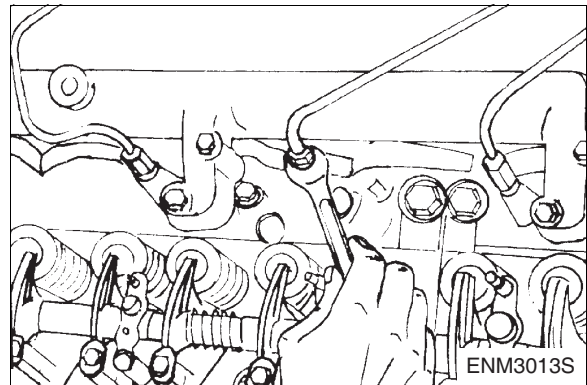

### 6.3.26. Cylinder Head Cover



- Assemble the new packing in the cylinder head cover, install the cover on the cylinder head, then tighten the fixing bolts in sequence to specified torque.

<b>Torque</b>	1.5 kg·m
---------------	----------

- Assemble the breather hose and the breather assembly.
- Assemble the oil filler cap in the cylinder head cover.

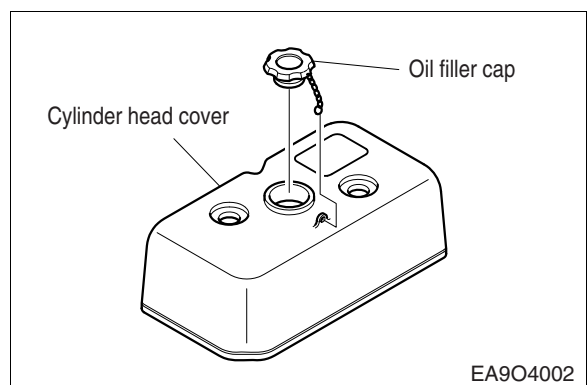
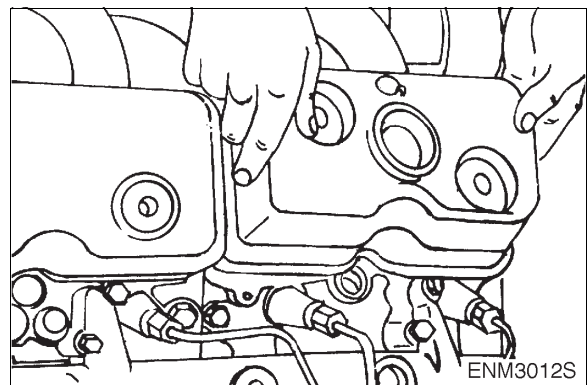

### 6.3.27. Injection Pump & Injection Timing

#### 1) Fuel injection pump

##### a) L086TI, AD086TI



- Install the injection pump bracket in the cylinder block.



- After measuring the amount of runout with an alignment setting jig, disassemble the bracket, adjust the shims, then reassemble it.

<b>Run Out</b>	0.2 mm or less
----------------	----------------



- Mount the top/bottom adjusting shims in the bracket and then mount the fuel injection pump.



- Tighten the fixing bolts in a diagonal sequence to specified torque.

<b>Torque</b>	4.4 kg-m
---------------	----------

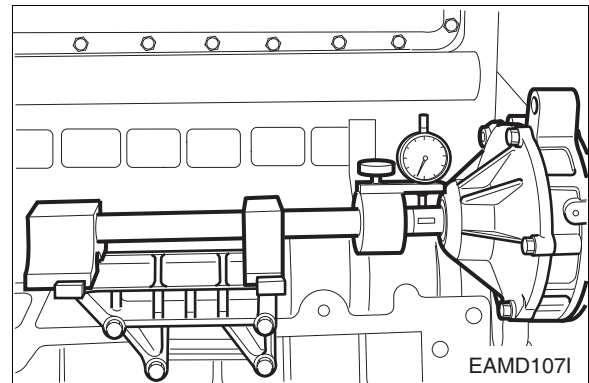

##### b) L136/T/TI, AD136/T/TI



- Reassemble the injection pump by using the engraved line as the figure.

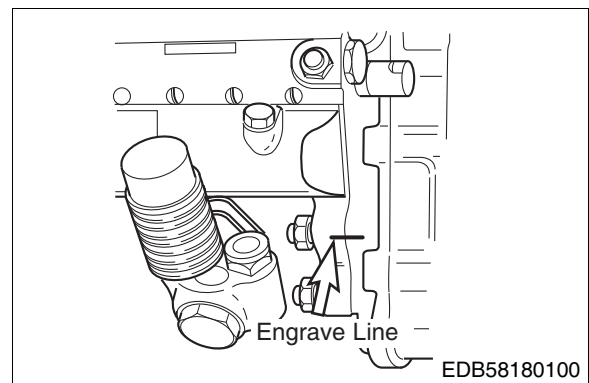

- To assemble the new injection pump, align the center of the hexagonal socket plug on the front side of the injection pump with the upper bolt hole of the injection pump flange.

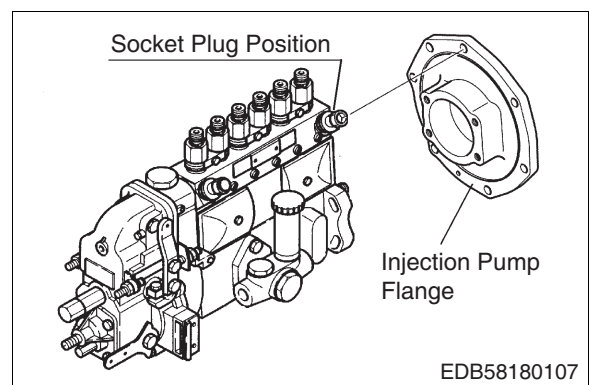

Then assemble the injection pump gear by aligning with the oil paint marking lines as figure.

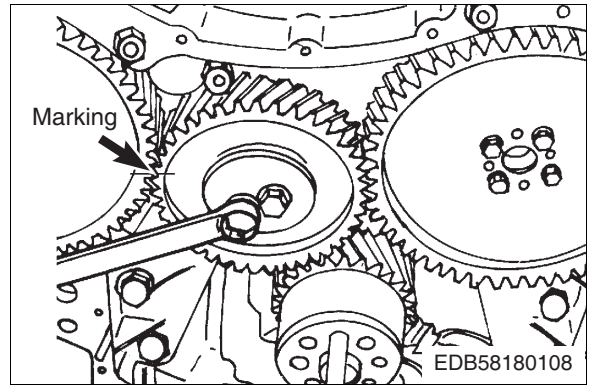

## 2) Injection Timing



- Turn the crank shaft until cylinder No. 6 is placed in the overlap TDC and then turn again the flywheel clockwise until the notch mark corresponding to the injection timing degree its model is aligned with hole center (←) in the flywheel as right figure.

### <Fuel injection timing>

Refer to "1. Engine specification" for each model.

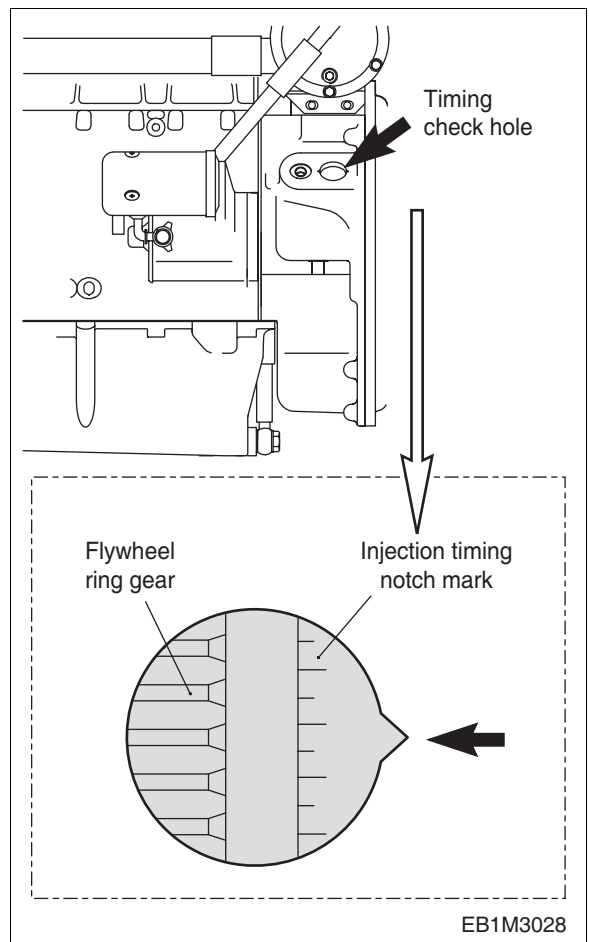

a) **L086TI, AD086TI**



- After letting the cylinder No. 6 at overlap TDC position, adjust the injection timing degree of the engine.
- After that, turn the injection pump until the notch mark of the pump indicator plate mounted is aligned with the notch mark of the drive shaft flange as right figure.

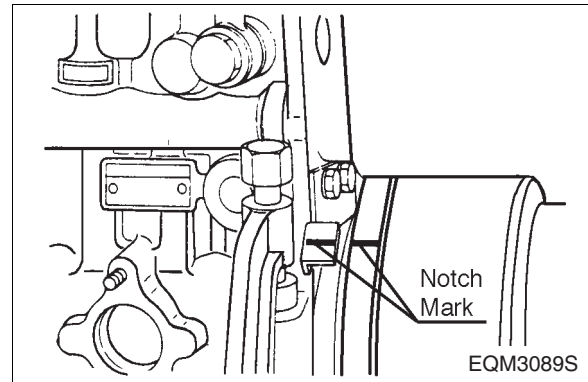

- Tighten the coupling housing fixing bolts and nuts to specified torque.

<b>Torque</b>	6.0 kg·m
---------------	----------



- Tighten the coupling housing fixing bolts and nuts to specified torque.

<b>Torque</b>	7.5 ~ 8.5 kg·m
---------------	----------------

- Install the oil delivery pipe and return pipe.
- At the same time, install the oil delivery pipe which feeds oil to the sea water pump.

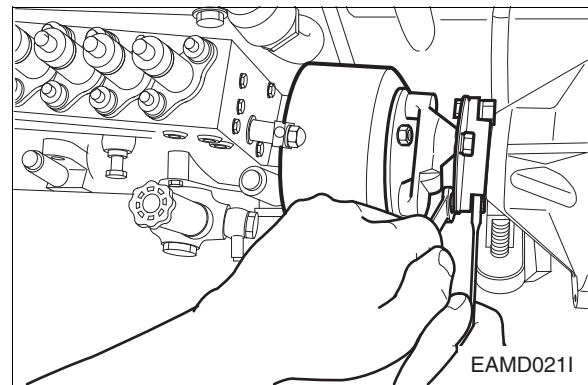

b) **How to check the fuel injection timing exactiy**



- To confirm the fuel injection pump timing, put the cylinder No. 6 in the overlap TDC position. And then remove the seat, spring and delivery valve from No. 1 plunger of the injection pump to check whether the fuel ejection or not from the injection pipe visually.



- Assemble the holder and pipe except seat, spring and delivery valve ("A" parts).

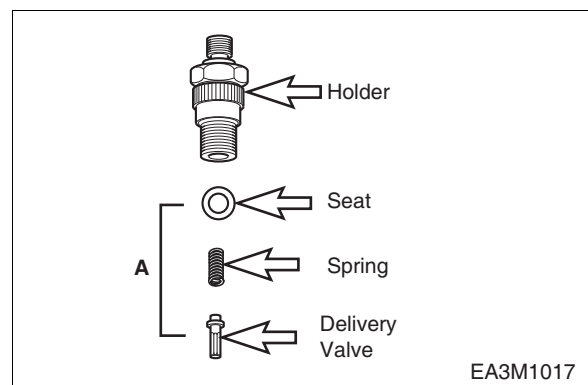

<b>Holder Torque</b>	4 ~ 4.5 kg·m
----------------------	--------------

- Turn the crank pulley clockwise slowly on pumping the priming pump to be continues simultaneously and you can see the point that fuel falls down by one drop per every 5 or 6 seconds from the fuel pipe No.1. This point is the very fuel injection timing degree.

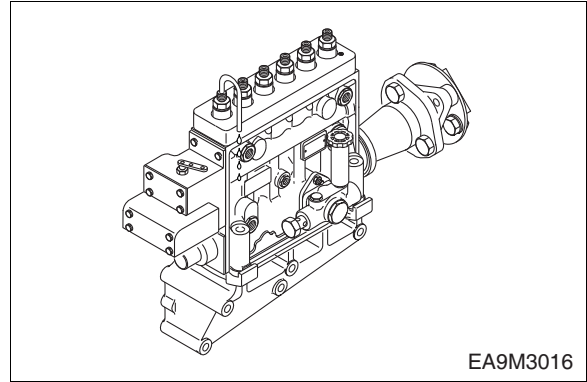

- After confirming the fuel injection timing, reassemble the holder and inner parts including seat, spring and delivery valve.



<b>Holder Torque</b>	4 ~ 4.5 kg·m
----------------------	--------------



- Connect the No. 1 fuel injection pipe and tighten as specified torque.

<b>Fuel Pipe Nut Torque</b>	3 ~ 3.5 kg·m
-----------------------------	--------------

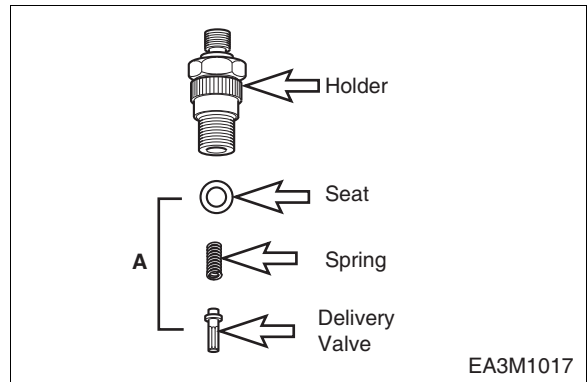

**CAUTION:** Do not too tighten the delivery valve holder to prevent the rack mal function of the fuel injection pump.  
In case of exchanging the injection pump, be sure to fill the engine oil in the governor before engine starting.

#### <Oil capacity of injection pump>

L136/T/TI AD136/T/TI	L086TI AD086TI
0.5 Lit.	0.7 Lit.

#### 6.3.28. Oil Cooler & Oil Filter

- After assembling the oil cooler onto the oil cooler housing, tighten the mounting bolts of the oil cooler assembly in the cylinder block inserting a new gasket.
- Lightly oil the O-ring and turn the oil filter cartridge until its O-ring is contacted against the sealing face of the oil filter head. And then turn the oil filter cartridge 3/4 ~ 1 turn more with hands or a filter wrench.
- Connect the cooling water pipes to the water pump and the heat exchanger.

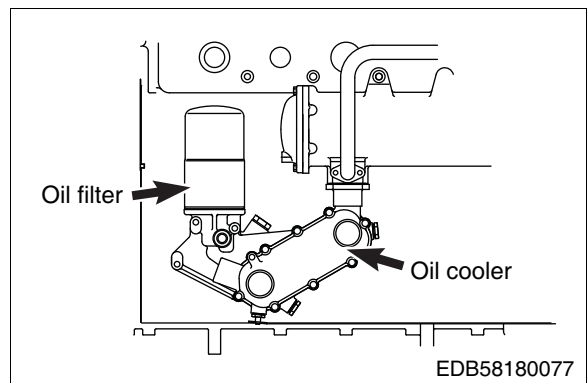

### 6.3.29. Water Pump

- Mount a new gasket.
- Install the water pump on the cylinder block and tighten the assembling bolts with specified torque.

<b>Torque</b>	2.2 kg·m
---------------	----------

- Connect cooling water pipe and the expansion tank each other.

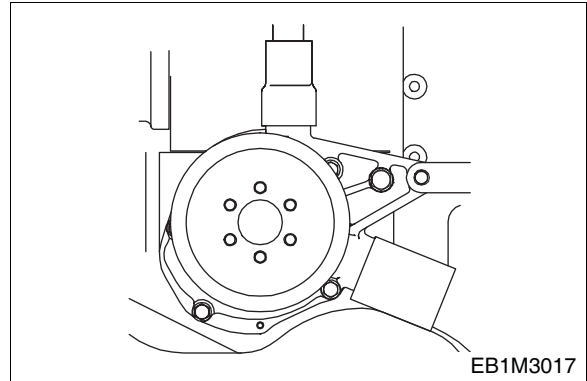

### 6.3.30. Sea Water Pump

- Mount a new gasket.
- Install the sea water pump on the timing gear case cover and tighten the assembling bolts with specified torque.

<b>Torque</b>	4.4 kg·m
---------------	----------

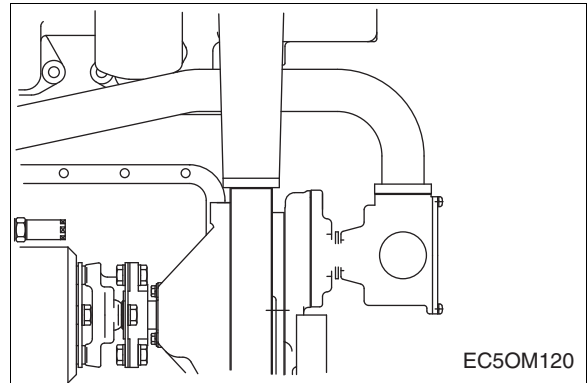

### 6.3.31. Heat Exchanger

- Install the heat exchanger on the flywheel housing, and tighten the fixing bolts with specified torque.

<b>Torque</b>	4.4 kg·m
---------------	----------

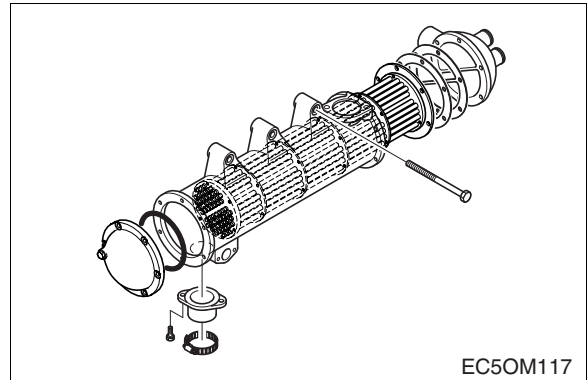

### 6.3.32. Thermostat

- Install the thermostat.
- Fit the new gasket on the thermostat housing, then assemble the thermostat housing with mounting bolts.
- Assemble the hose clamps in both sides of the heat exchanger and cooling water pipe.

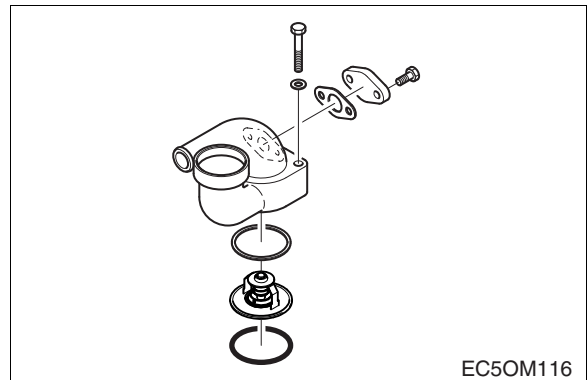

### 6.3.33. Exhaust Manifold

- Assemble the exhaust manifold with steel gasket in order to be installed in the small hole between two holes of the gasket upward and be sure to check the squared port of the gasket whether the square port of the cylinder head is aligned before assembling.
- Tighten the fixing bolts with specified torque.

<b>Torque</b>	M10	4.4 kg·m
	M12	7.5 kg·m

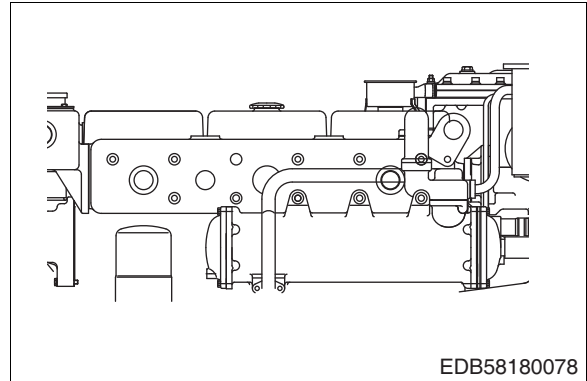

### 6.3.34. Intake Manifold

- Assemble the intake manifold including the gasket.
- Connect the air hose to the boost compensator of the fuel injection pump.

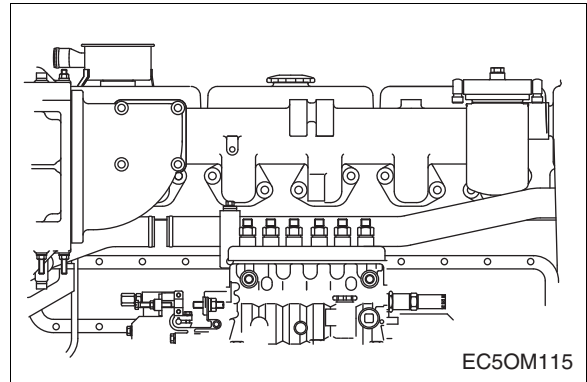

### 6.3.35. Stop Solenoid (L086TI)

- Assemble the brackets on the injection pump body.
- Install the stop solenoid and tighten the fixing bolts.
- Connect the tie rod to fuel feed pump and stop solenoid.

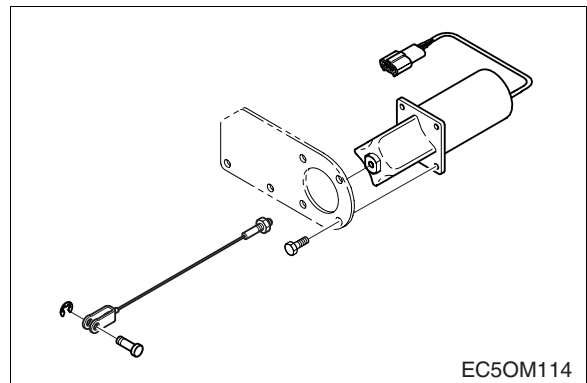

### 6.3.36. Injection Pipe

- Semi-assemble nuts at both ends of the fuel high pressure pipe and tighten them up one by one to specified torque.

<b>Torque</b>	3.0 kg·m
---------------	----------

- Tighten the hollow screws to assemble the fuel return pipe.
- Assemble the fuel return hose to the fuel injection pump.

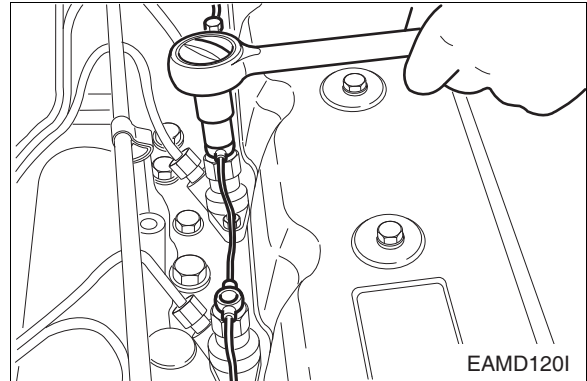

### 6.3.37. Starter

- Assemble the starter in position on the flywheel housing.

<b>Torque</b>	8.0 kg·m
---------------	----------

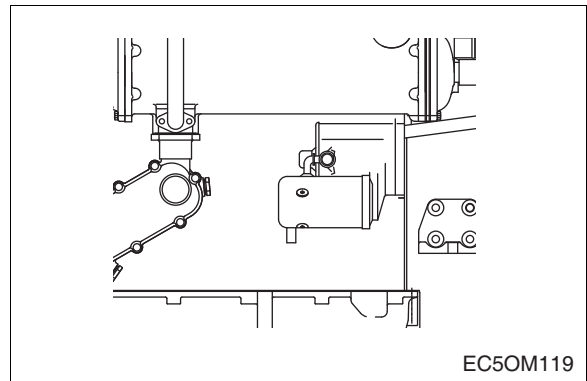

### 6.3.38. Intercooler

- After sub-assembling the air inlet & outlet pipe and sea water inlet & outlet cooling water pipe in the heat exchanger separately assemble the intercooler assembly on the bracket of the heat exchanger.
- Insert the hoses each pipe and clamp the hoses separately.

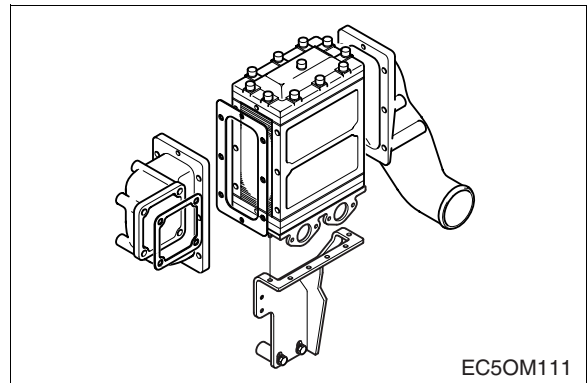

### 6.3.39. Turbocharger

- Insert a new gasket on the exhaust outlet pipe and mount the turbocharger.
- Install the oil supply & return pipe.
- Clamp the rubber hose connected to the air inlet pipe of the inter cooler, and assemble the cooling water inlet & outlet pipe.

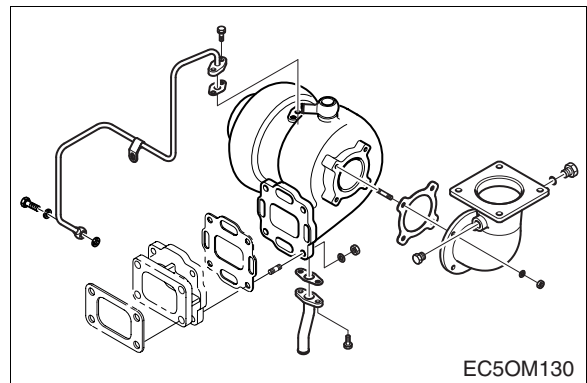

#### 6.3.40. Air Cleaner

- Assemble the air cleaner and tighten the bolt and nut of clamp properly.
- Finally install the air filter element.

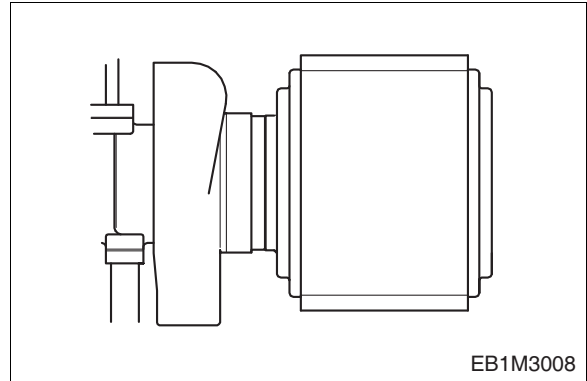

#### 6.3.41. Expansion Tank and Reservoir Tank

- Assemble the expansion tank and rubber hose for by-pass pipe, and then tighten the clamp.
- Finally assemble the reservoir tank using holder and connect the hose between the expansion tank and reservoir tank.

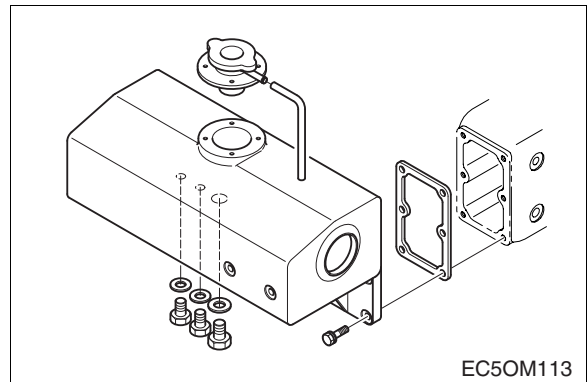

#### 6.3.42. Fuel Filter

- Assemble the fuel filter on the right of intake manifold as figure.
- Assemble the fuel feed hose according to the direction of the arrow impressed on the fuel filter head so that fuel can be fed in the sequence of **FUEL FEED PUMP R FUEL FILTER R FUEL INJECTION PUMP.**

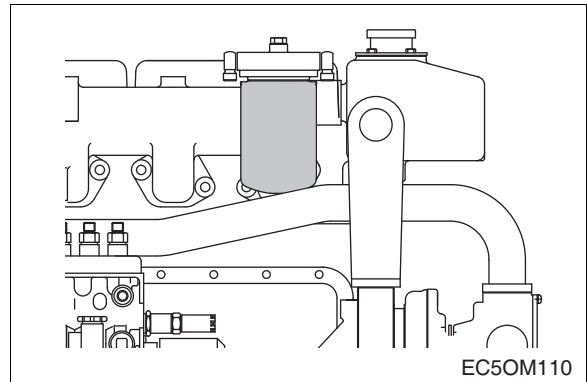

#### 6.3.43. Alternator

- Install the alternator mounting bracket.
- Assemble the alternator and protector.

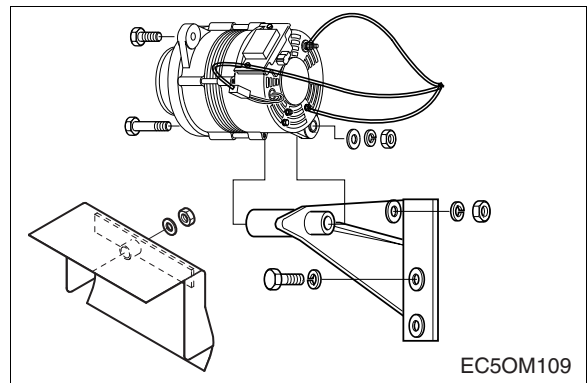

#### 6.3.44. V-Belt

- Install the V-belt on the crank pulley and alternator.
- Adjust the V-belt tension using the tension adjusting bolt.

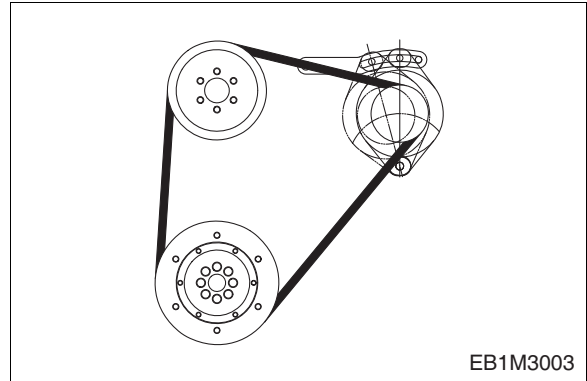

#### 6.4. Break-in After Maintenance

Because the sliding parts of a new or an overhauled engine are not lapped enough, the oil film can be destroyed easily by overload or over-speed and the engine life time may be shorten. Therefore the operator must follow the things of "**3.3 Engine Break-in**" by all means.



## 7. Main Parts Maintenance

### 7.1. Lubricating System

Lubricating oil pumped by the gear oil pump in the oil pan is filtrated in the oil filter through oil cooler. This filtrated oil passed on the main oil gallery of the cylinder block where is distributed to lubricate the various sliding parts, fuel injection pump, and turbo-charger etc also in order to ensure normal engine performance.

#### 7.1.1. Specifications

Item	Specifications
Lubricating system	Forced pressure circulation
Oil pump type	Gear type
Relief valve opening pressure	$10 \pm 1.5 \text{ kg/cm}^2$
Bypass for oil cooler opening pressure	$5 + 1 \text{ kg/cm}^2$
Adjusting valve for spray nozzle opening pressure	$1.5 \sim 1.8 \text{ kg/cm}^2$
Oil filter type	Full flow
Bypass for filter element	Cartridge type
Valve opening pressure	$1.8 \sim 2.3 \text{ kg/cm}^2$
Bypass for entire oil filter valve opening pressure	$4.0 \sim 4.8 \text{ kg/cm}^2$

#### 7.1.2. Oil Pump

- Disassembly



(1) Disassembly of oil pump drive gear

- Unscrew the screw and disassemble the oil relief valve.
- Unfold the washer for the oil pump drive gear fixing nut and remove the nut.
- Disassemble the drive gear.

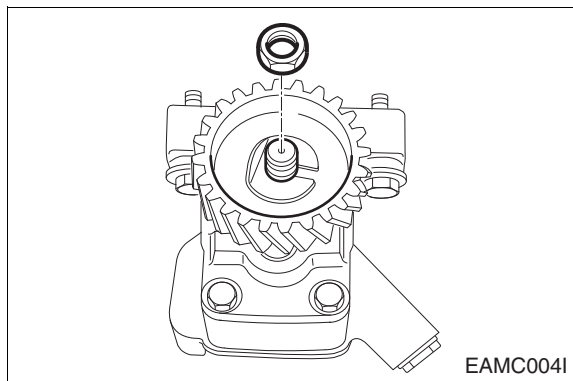

- (2) Remove the oil pump cover fixing nuts and disassemble the oil pump cover.  
The oil pump cover is fixed with the two dowel pins.
- (3) Disassemble the drive and driven gear.

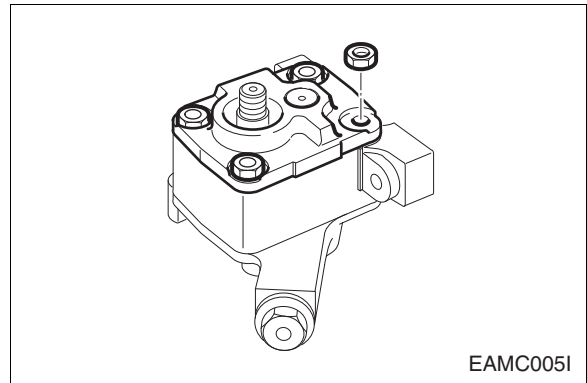

● **Inspection and Correction**



- (1) With steel ruler and feeler gauge, measure the axial end play of the oil pump gear. Replace if the measured value is beyond the limit.

<b>Limit</b>	0.025 ~ 0.089 mm
--------------	------------------

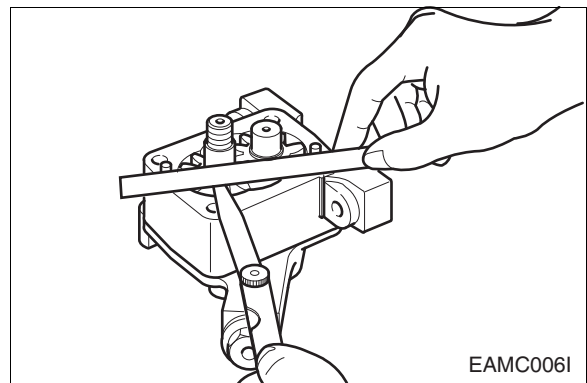

- (2) With a feeler gauge, measure the amount of backlash between the oil pump drive gear and driven gear. Replace if the measured value is beyond the limit.

<b>Limit</b>	0.050 ~ 0.64 mm
--------------	-----------------

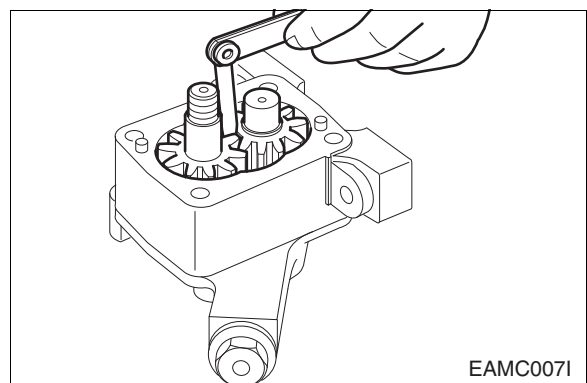

- (3) Measuring clearance between drive shaft and bushing

- a) Measure the outside diameter of the drive shaft and driven shaft, and replace if the measured values are less than the limit.

<b>Limit</b>	16.95 mm
--------------	----------

- b) Measure the inside diameter of the pump body bushing to determine the clearance between the bushing and shaft, and compare the measured value with the standard value to determine whether to replace or not.

**<Clearance between oil pump shaft and bush>**

<b>Standard</b>	0.032 ~ 0.077 mm
-----------------	---------------------



● **Re-assembly**

- (1) For re-assembly, reverse the disassembly sequence.

## 7.2. Cooling System

### 7.2.1. Cooling Water Pump

- Loosen the bolt (8) and remove the pulley (12).



- Unscrew the socket bolt (7) and detach the housing cover (5).

- After heating on the impeller (3) a little remove the impeller using a special jig.

- Detach the mechanical seal (4).



- Heat on the hub (9) little by little and then remove the hub using a removing jig.

- After detach the snap ring (11) remove the unit bearing shaft.

- Follow the re-assembly on contrary to order of disassembly.

- Exchange the oil seal (4) to a new one.



- If the used impeller is re-assembled, keep the clearance between the pump housing and impeller not to be more than 0.35 mm.

#### <Water pump assembly>

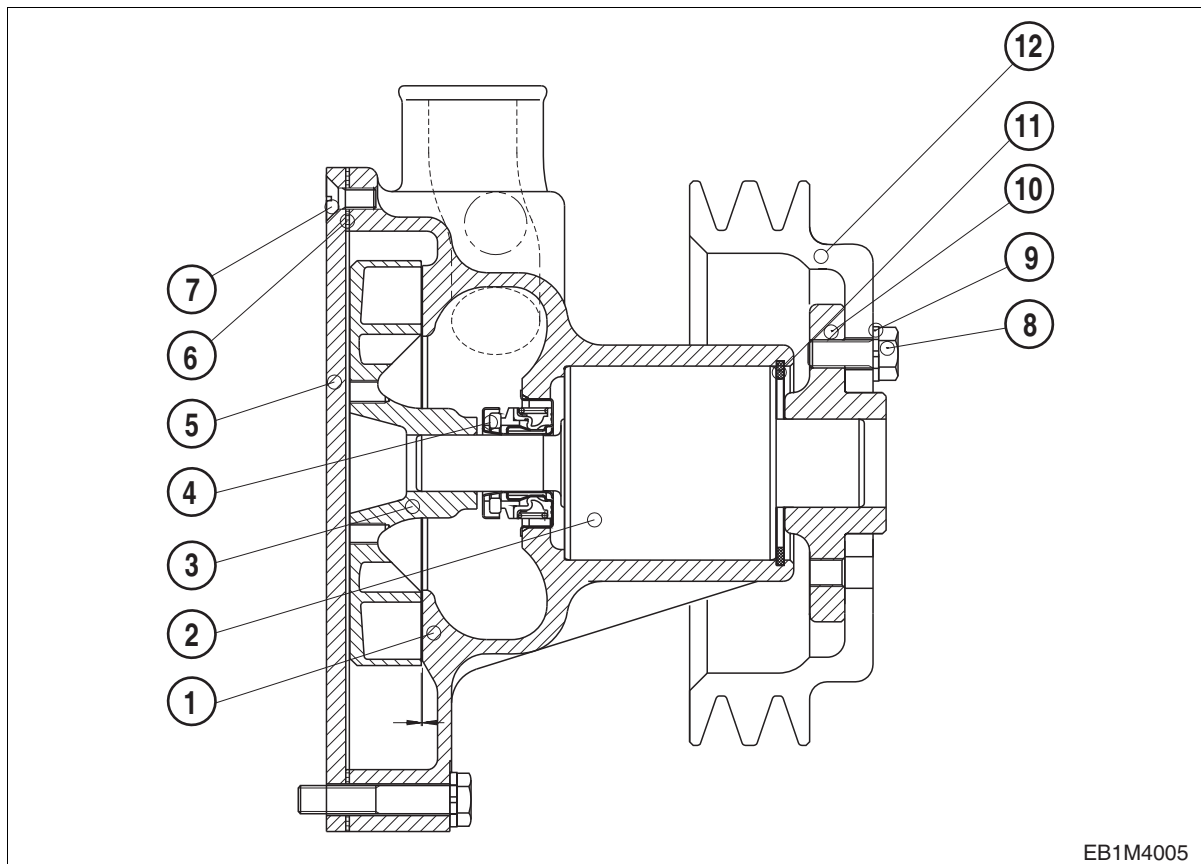

1. Water pump housing
2. Unit bearing & shaft
3. Impeller
4. Mechanical seal

5. Housing cover
6. Gasket
7. Socket bolt
8. Hex bolt

9. Spring washer
10. Hub
11. Snap ring
12. Pulley

## 7.3. Fuel System

### 7.3.1. Injection Pump

The components relating to the injection pump should be serviced at regular intervals as the plunger and delivery valve may be worn after a given length of time for use and cause the deterioration of the engine.



*Make sure that servicing should be performed at the professional maintenance shop as authorized by bosch or zexel company.*

For adjustment of fuel injection volume, refer to the 'Specifications of fuel injection pump' described on the following pages.

#### 1) L136, AD136

##### (1) Main specification

Fuel injection pump	: 65.11101-7269A
Governor type	: RSV
Model type	: PES6AD
Cam lift	: 11 mm
Fuel feed pump	: 105210-4830
Injection timing	: BTDC 22° ±1°
Injection order	: 1-5-3-6-2-4
Rotating direction	: Clockwise (Viewed at driving gear side)

##### (2) Calibration data

(A) Test condition for injection pump	Nozzle & Holder Ass'y	105780-8140	Opening pressure: 175 kg/cm <sup>2</sup>
	Injection pipe (ID, OD, L)	-	ø8.0 x ø2.0 - 600 mm
	Test oil	ISO4113	Temperature: 40 ±5°C
(B) Engine standard parts	Nozzle & holder Ass'y	65.10101-7050	Nozzle (5 x ø0.36)
		-	214 + 8 kg/cm <sup>2</sup>
	Injection pipe (ID, OD, L)	-	ø6 x ø2.2 - 650 mm

Rack diagram and setting valve at each point

Refer to (3) rack diagram	Check point	Rack position (mm)	Pump speed (rpm)	Injection Q'ty on RIG (mm <sup>3</sup> /1,000st)		Press. (mmHg)
				(A) Test condition for inj. Pump	Max. Var. Bet. Cyl. (%)	
	A	10.5	1,100	88.5 ±2	±2.5	Full
	B	7.7	370	11.5 ±2	±25	Idle
	C	≈	100	(135)	-	-
Balance weight	740g		Lever ratio (min/max)		1 : 1.2	
Governor spring	k = 7.2 kg/mm		Plunger		ø9.5, 20 + 45 lead	
Idle spring	k = 1.9 kg/mm		Delivery valve retraction volume		70 mm <sup>3</sup> /st, t = 0.11	
Idle sub spring	k = 3.0 kg/mm		Delivery valve opening pressure		23.1 kg/cm <sup>2</sup>	
Start spring	k = 0.01 kg/mm		Delivery valve spring		k = 1.63 kg/mm	
Max. discharge pressure	k = 3.4 kg/mm <sup>2</sup>		Feed pump		105210-5280 (KP-FP/KE-ADS)	

**(3) Rack diagram**

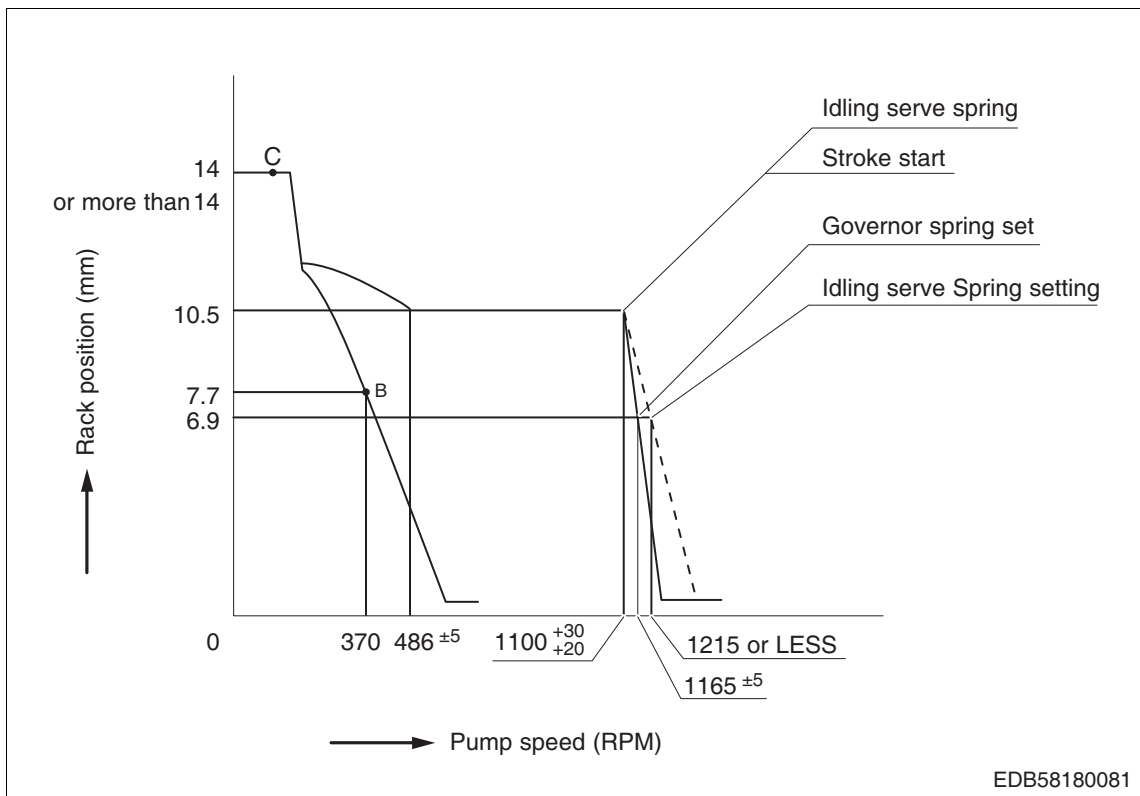

EDB58180081

2) L136T, AD136T

(1) Main specification

Fuel injection pump : 65.11101-7271A  
 Model type : PES6AD  
 Governor type : RSV  
 Fuel feed pump : 105210-4830  
 Cam lift : 11 mm  
 Injection timing : BTDC 18° ±1°  
 Injection order : 1-5-3-6-2-4  
 Rotating direction : Clockwise (Viewed at driving gear side)

(2) Calibration data

(A) Test condition for injection pump	Nozzle & Holder Ass'y	105780-8140	Opening pressure: 175 kg/cm <sup>2</sup>			
	Injection pipe (ID, OD, L)	-	ø8.0 x ø2.0 - 600 mm			
	Test oil	ISO4113	Temperature: 40 ±5°C			
(B) Engine standard parts	Nozzle & holder Ass'y	65.10101-7050	Nozzle (5 x ø0.36)			
		-	214 + 8 kg/cm <sup>2</sup>			
	Injection pipe (ID, OD, L)	-	ø6 x ø2.2 - 650 mm			
Rack diagram and setting valve at each point						
Refer to (3) rack diagram	Check point	Rack position (mm)	Pump speed (rpm)	Injection Q'ty on RIG (mm <sup>3</sup> /1,000st)		Press. (mmHg)
				(A) Test condition for inj. Pump	Max. Var. Bet. Cyl. (%)	
	A	10.5	1,100	113.5 ±2	±2.5	Full
	B	7.9	370	11.5 ±2	±25	Idle
C	≈	100	-	-	-	
Balance weight	740g	Lever ratio (min/max)		1 : 1.2		
Governor spring	k = 7.2 kg/mm	Plunger		ø9.5, 20 + 45 lead		
Idle spring	k = 1.9 kg/mm	Delivery valve retraction volume		70 mm <sup>3</sup> /st, t = 0.11		
Idle sub spring	k = 3.0 kg/mm	Delivery valve opening pressure		23.1 kg/cm <sup>2</sup>		
Start spring	k = 0.01 kg/mm	Delivery valve spring		k = 1.63 kg/mm		
Max. discharge pressure	k = 3.4 kg/mm <sup>2</sup>	Feed pump		105210-5280 (KP-FP/KE-ADS)		

**(3) Rack diagram**

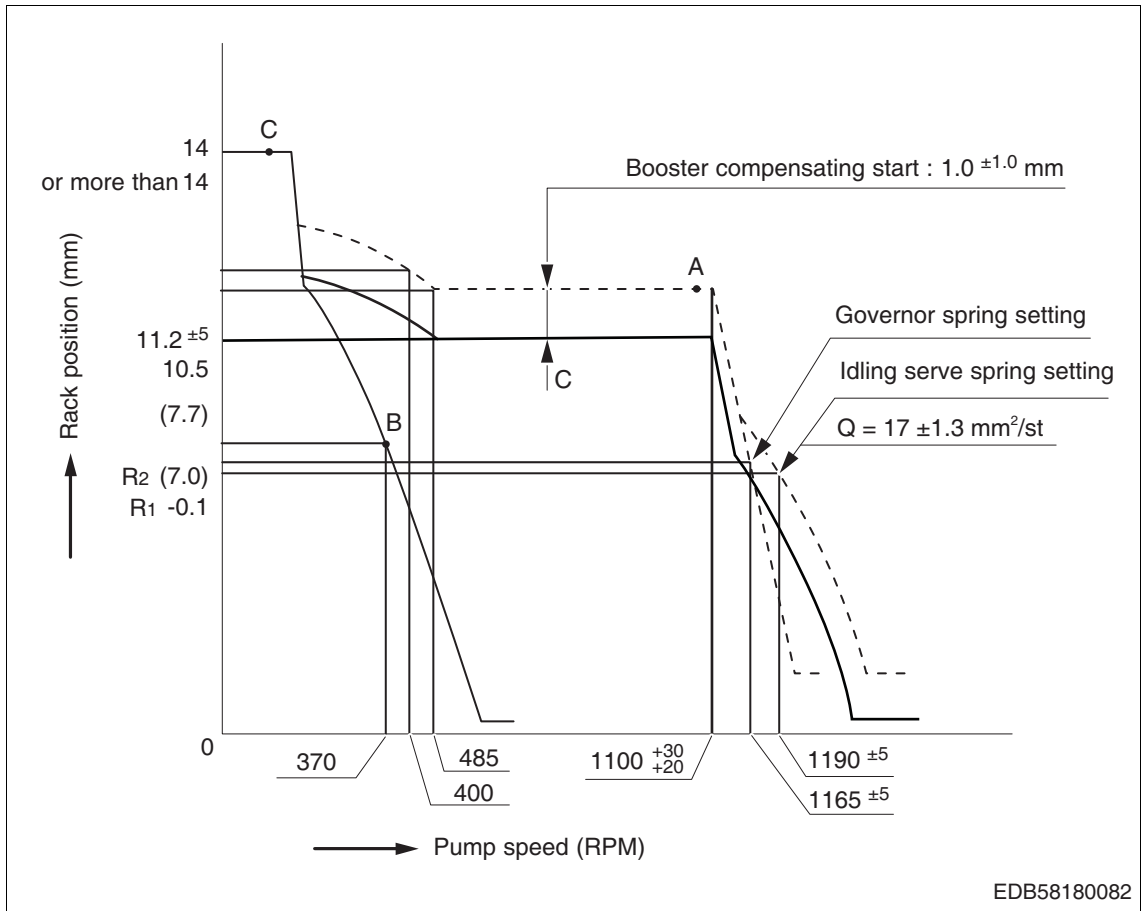

EDB58180082



**(3) Rack diagram**

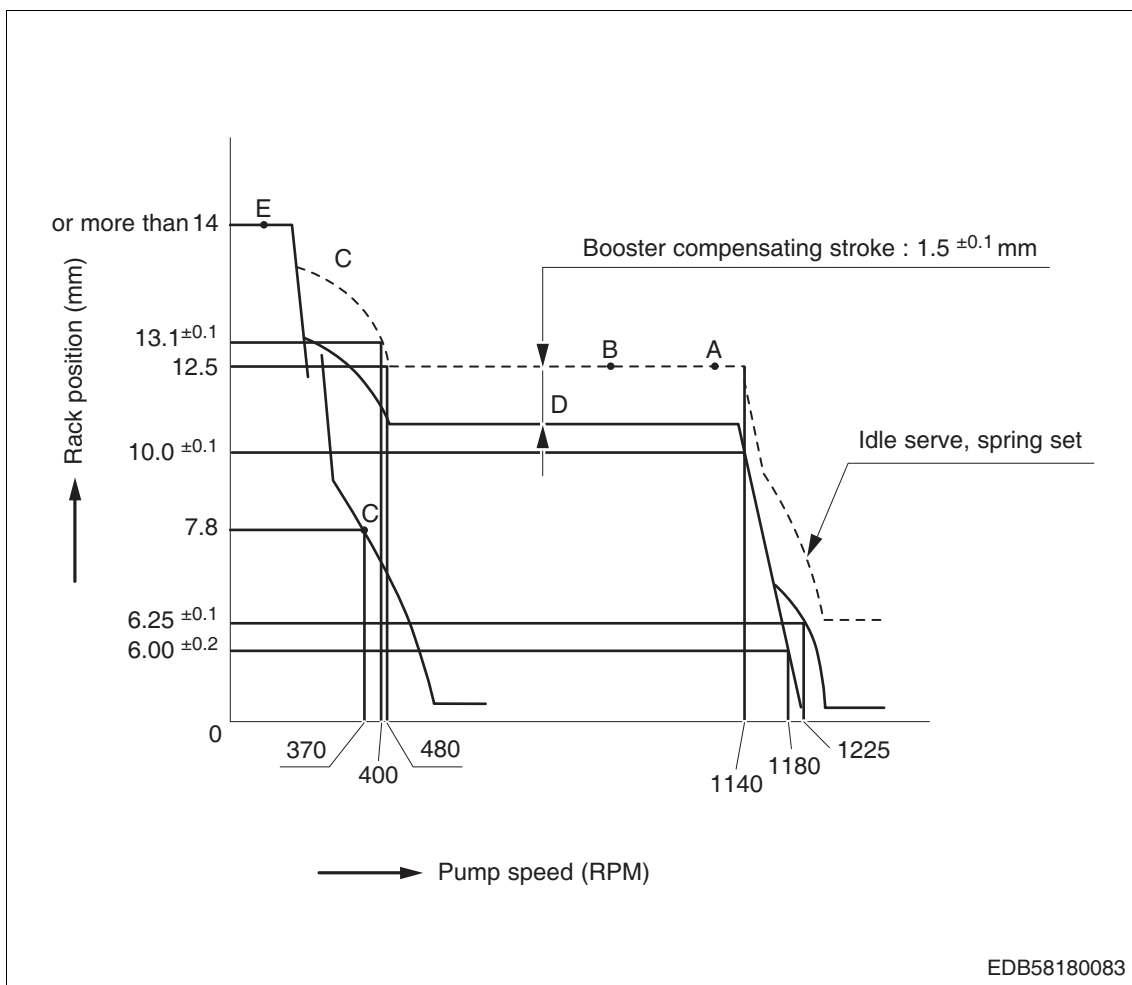

EDB58180083

#### 4) L086TIH, AD086TI

##### (1) Main specification

Fuel injection pump	: 65.11101-7311
Model type	: PE6P120/720RS3S
Governor type	: RSV 200/1300
Plunger	: 134153-1420
Delivery valve	: 134110-1420
Fuel feed pump	: 105237-5470
Cam lift	: 12 mm
Injection timing	: BTDC 15° ±1°
Injection order	: 1-5-3-6-2-4
Rotating direction	: Clockwise (Viewed at driving gear side)

##### (2) Calibration data

(A) Test condition for injection pump	Nozzle & Holder Ass'y	105780-8140	Opening pressure: 175 kg/cm <sup>2</sup>			
	Injection pipe (ID, OD, L)	-	ø8.0 x ø3.0 - 600 mm			
	Test oil	ISO4113	Temperature: 40 ±5°C			
(B) Engine standard parts	Nozzle & holder Ass'y	65.10101-7450	Nozzle (5 x ø0.36)			
		LRC6703709	214 + 8 kg/cm <sup>2</sup>			
	Injection pipe (ID, OD, L)	65.10301-6049A 65.10301-6052A	ø6.35 x ø2.2 - 650 mm			
Rack diagram and setting valve at each point						
Refer to (3) rack diagram	Check point	Rack position (mm)	Pump speed (rpm)	Injection Q'ty on RIG (mm <sup>3</sup> /1,000st)		Press. (mmHg)
				(A) Test condition for inj. Pump	(B) Engine standard parts	
	A	12.2	1,050	169.5 ±2.0	±2	980≤
	B	(6.7)	315	10.0 ±1.3	±15	-
	C	12.2	500	(177)	-	980≤
D	10.0	500	(103) ±3	-	-	
Boost pressure dependent full - load stop (boost compensator spring operation point)						
Refer to (4) boost pressure	Check point	Rack position (mm)	Pump speed (rpm)	Injection Q'ty on RIG (mm <sup>3</sup> /1,000st)		Press. (mmHg)
				(A) Test condition for inj. Pump	(B) Engine standard parts	
	P1	10.0	500	177	-	150
	P2	12.2	500	103	-	880
-	-	-	-	-	-	
Weight	Weight = 740 kg		Lever ratio (min/max)		Min. speed 1 : 1.2 Max. speed 1 : 1.2	
Governor spring	k = 7.2 kg/mm		Plunger		ø12, 30 lead	
Idle spring	k = 1.9 kg/mm		Delivery valve retraction volume		100 mm <sup>3</sup> /st, t = 0.09	
Idle sub spring	k = 1.2 kg/mm		Delivery opening pressure		18.5 kg/cm <sup>2</sup>	
Start spring	k = 0.01 kg/mm		Delivery valve spring		k = 0.87 kg/mm	
Boost compensator spring	k = 1.0 kg/mm		Feed pump		105237-5470 (NP-FP/KD-PS)	

**(3) Rack diagram**

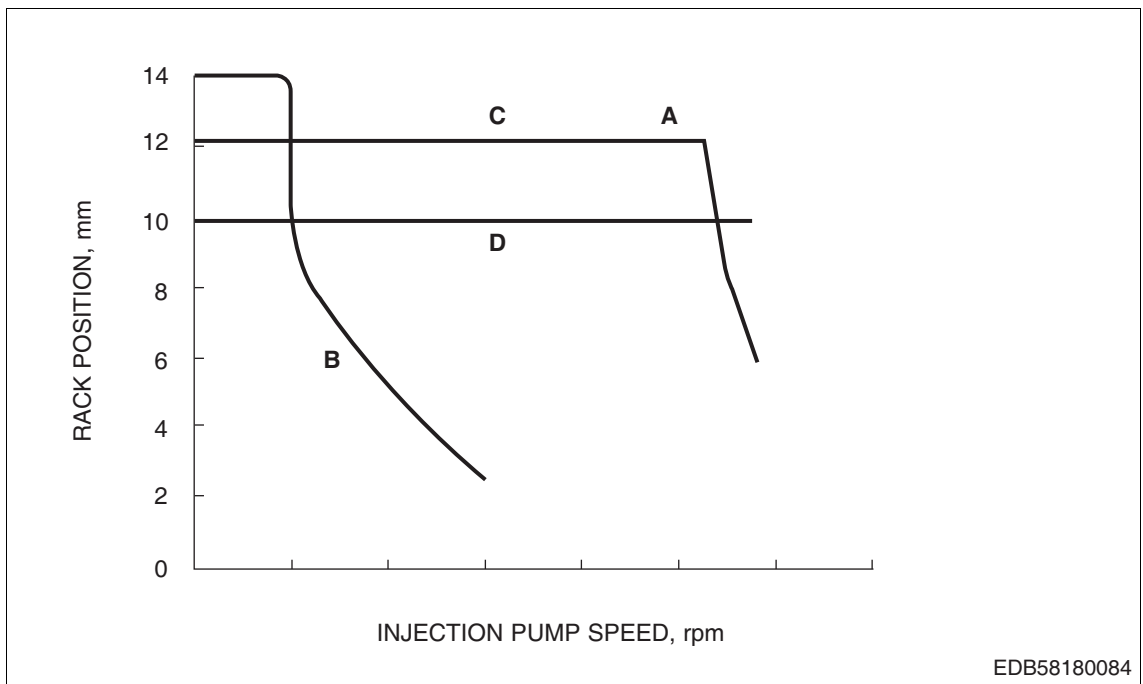

**(4) Boost compensator pressure**

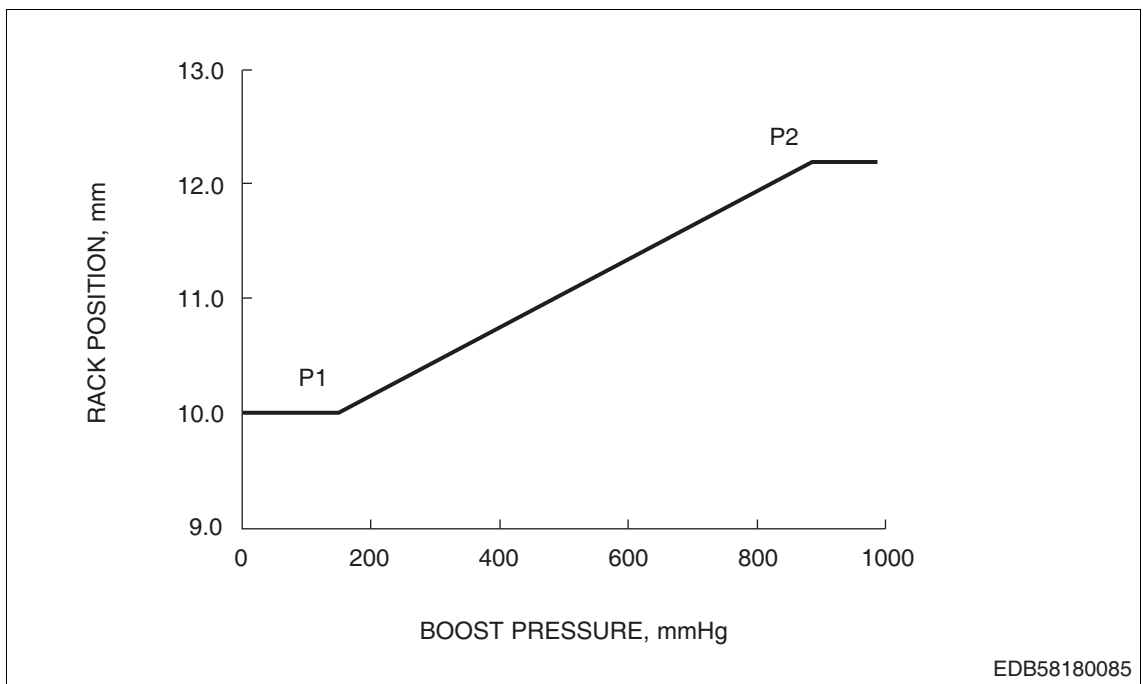

5) **L086TIM**

(1) **Main specification**

Fuel injection pump : 65.11101-7311  
 Model type : PE6P120/720RS3S  
 Governor type : RSV 200/1300  
 Plunger : 134153-1420  
 Delivery valve : 134110-1420  
 Fuel feed pump : 105237-5470  
 Cam lift : 12 mm  
 Injection timing : BTDC 15° ±1°  
 Injection order : 1-5-3-6-2-4  
 Rotating direction : Clockwise (Viewed at driving gear side)

(2) **Calibration data**

(A) Test condition for injection pump	Nozzle & Holder Ass'y	105780-8140	Opening pressure: 175 kg/cm <sup>2</sup>			
	Injection pipe (ID, OD, L)	-	ø8.0 x ø3.0 - 600 mm			
	Test oil	ISO4113	Temperature: 40 ±5°C			
(B) Engine standard parts	Nozzle & holder Ass'y	65.10101-7450	Nozzle (5 x ø0.36)			
		LRC6703709	214 + 8 kg/cm <sup>2</sup>			
	Injection pipe (ID, OD, L)	65.10301-6049A 65.10301-6052A	ø6.35 x ø2.2 - 650 mm			
Rack diagram and setting valve at each point						
Refer to (3) rack diagram	Check point	Rack position (mm)	Pump speed (rpm)	Injection Q'ty on RIG (mm <sup>3</sup> /1,000st)		Press. (mmHg)
				(A) Test condition for inj. Pump	(B) Engine standard parts	
	A	12.4	1,150	178.7 ±5.0	Max. Power	-
	B	8.1	700	19.1 ±1.0	-	-
	C	12.4	500	182.2 ±3.0	-	-
	D	10.0	500	99.5 ±3.0	-	-
E	W/Cap	100	225.3 ±3.0	-	-	
Boost pressure dependent full - load stop (boost compensator spring operation point)						
Refer to (4) boost pressure	Check point	Rack position (mm)	Pump speed (rpm)	Injection Q'ty on RIG (mm <sup>3</sup> /1,000st)		Press. (mmHg)
				(A) Test condition for inj. Pump	(B) Engine standard parts	
	P1	12.4	500	178.7 ±5.0	-	1,020
P2	10.0	500	99.5 ±3.0	-	150	
Weight	Weight = 740 kg		Lever ratio (min/max)		Min. speed 1 : 1.2 Max. speed 1 : 1.2	
Governor spring	k = 7.2 kg/mm		Plunger		ø12, 30 lead	
Idle spring	k = 1.9 kg/mm		Delivery valve retraction volume		100 mm <sup>3</sup> /st, t = 0.09	
Idle sub spring	k = 1.2 kg/mm		Delivery opening pressure		18.5 kg/cm <sup>2</sup>	
Start spring	k = 0.01 kg/mm		Delivery valve spring		k = 0.87 kg/mm	
Boost compensator spring	k = 1.0 kg/mm		Feed pump		105237-5470 (NP-FP/KD-PS)	

**(3) Rack diagram**

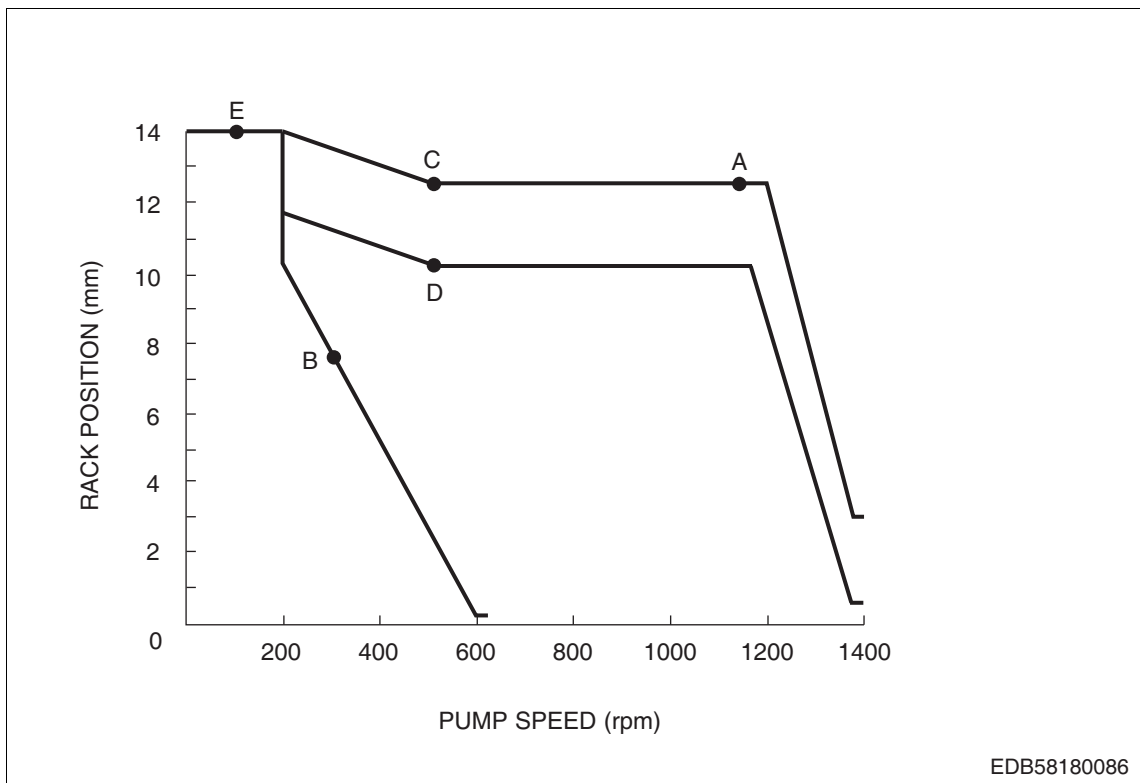

**(4) Boost compensator pressure**

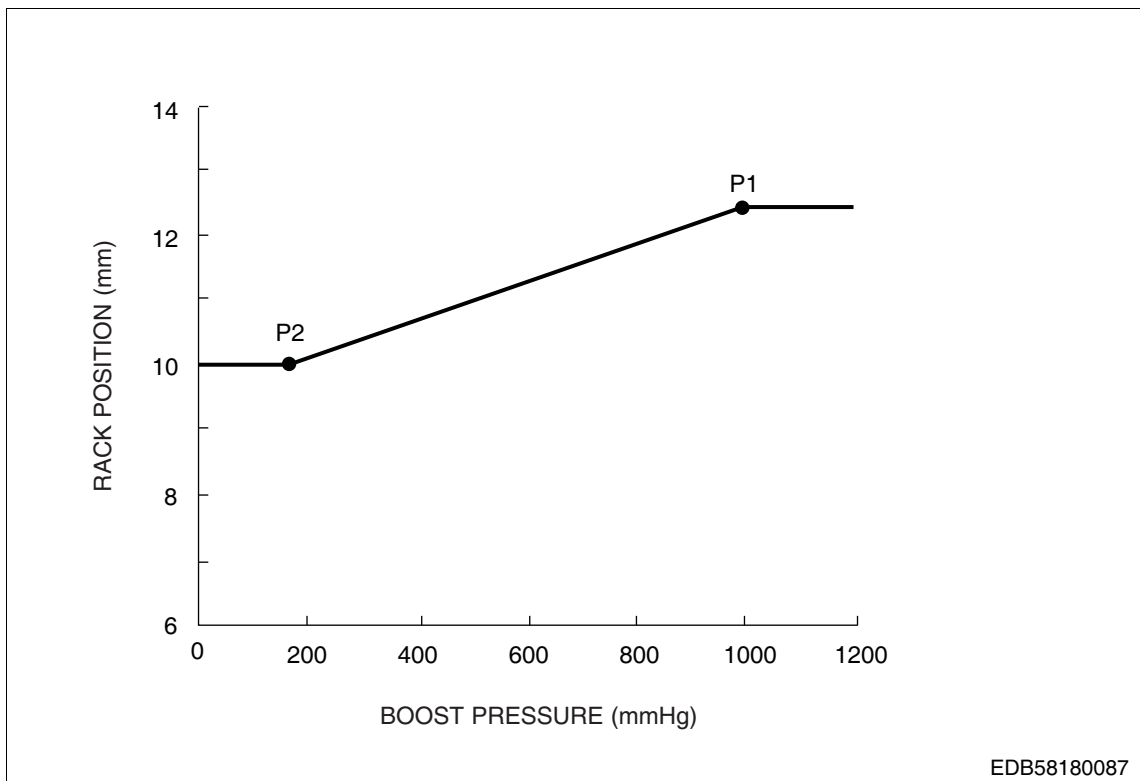

## 6) L086TIL

### (1) Main specification

Fuel injection pump	: 65.11101-7430A
Model type	: PE6P120/720RS3S
Governor type	: RSV 200/1300
Plunger	: 134153-1420
Delivery valve	: 134110-1420
Fuel feed pump	: 105237-5470
Cam lift	: 3.90 ±0.05 mm
Injection timing	: BTDC 15° ±1°
Injection order	: 1-5-3-6-2-4
Rotating direction	: Clockwise (Viewed at driving gear side)

### (2) Calibration data

(A) Test condition for injection pump	Nozzle & Holder Ass'y	105780-8140	Opening pressure: 175 bar			
	Injection pipe (ID, OD, L)	-	ø3.0 x ø8.0 - 600 mm			
	Test oil	ISO4113	Temperature: 40 ±5°C			
(B) Engine standard parts	Nozzle & holder Ass'y	65.10101-7096	Opening pressure: 257 bar			
	Nozzle	65.10102-6066	ø0.288 x 7 Hole			
	Injection pipe (ID, OD, L)	420208-00002 65.10301-6052B	ø2.2 x ø6.35 x 650 mm			
Rack diagram and setting valve at each point						
Refer to (3) rack diagram	Check point	Rack position (mm)	Pump speed (rpm)	Injection Q'ty on RIG (mm <sup>3</sup> /1,000st)		Press. (mmHg)
				(A) Test condition for inj. Pump	(B) Engine standard parts	
	A	12.72	1,250	214.3 ±3.0	-	1,500
	B	6.60	375	11.1 ±1.0	-	0
	C	12.83	500	212.3 ±3.0	-	1,500
	D	10.67	500	138.3 ±3.0	-	0
E	W/Cap	100	253.0 ±3.0	-	0	
Boost pressure dependent full - load stop (boost compensator spring operation point)						
Refer to (4) boost pressure	Check point	Rack position (mm)	Pump speed (rpm)	Injection Q'ty on RIG (mm <sup>3</sup> /1,000st)		Press. (mmHg)
				(A) Test condition for inj. Pump	(B) Engine standard parts	
	P1	10.67	500	138.3 ±3.0	-	160
P2	12.83	500	212.3 ±3.0	-	925	
Weight	Weight = 740 g		Lever ratio (min/max)		Min. speed 1 : 1.2 Max. speed 1 : 1.2	
Governor spring	k = 7.2 kg/mm		Plunger		ø12	
Idle spring	k = 1.9 kg/mm		Delivery valve retraction volume		100 mm <sup>3</sup> /st, t = 0.09	
Start spring	k = 0.01 kg/mm		Delivery valve opening pressure		18.5 kg/cm <sup>2</sup>	
Boost compensator spring	k = 1.0 kg/mm		Delivery valve spring		k = 0.87 kg/mm	
			Feed pump		105237-5470 (NP-FP/KD-PS)	

**(3) Rack diagram**

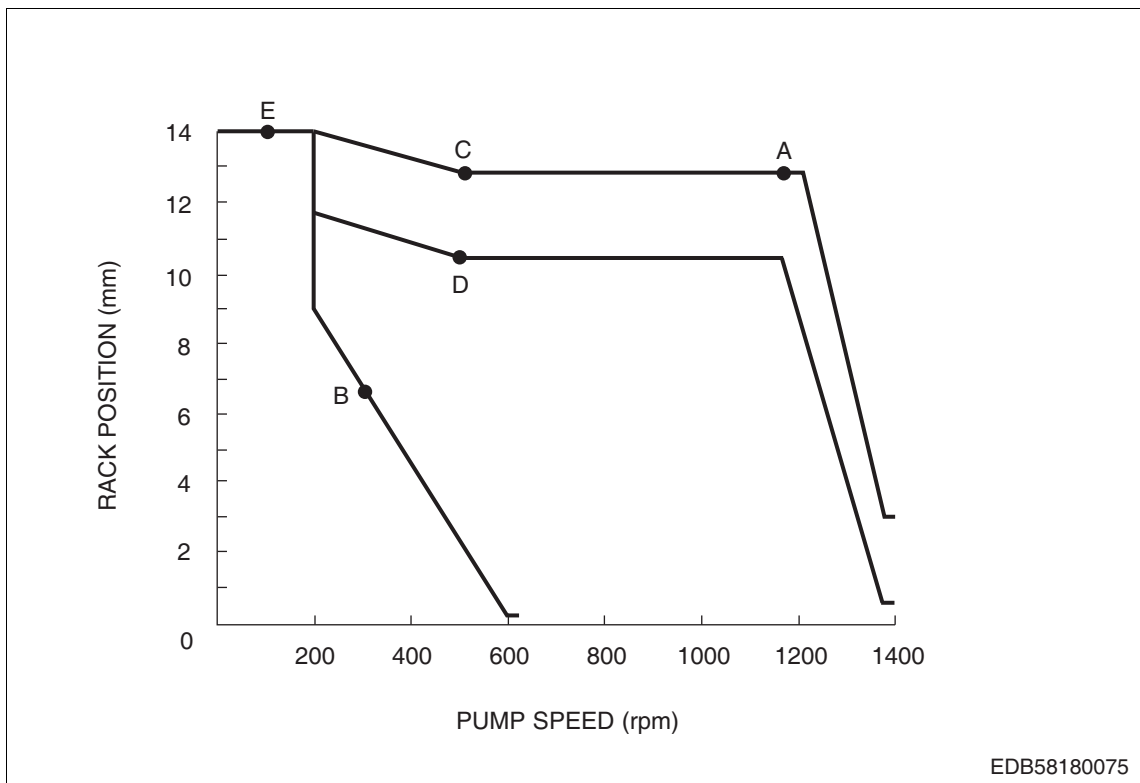

**(4) Boost compensator pressure**

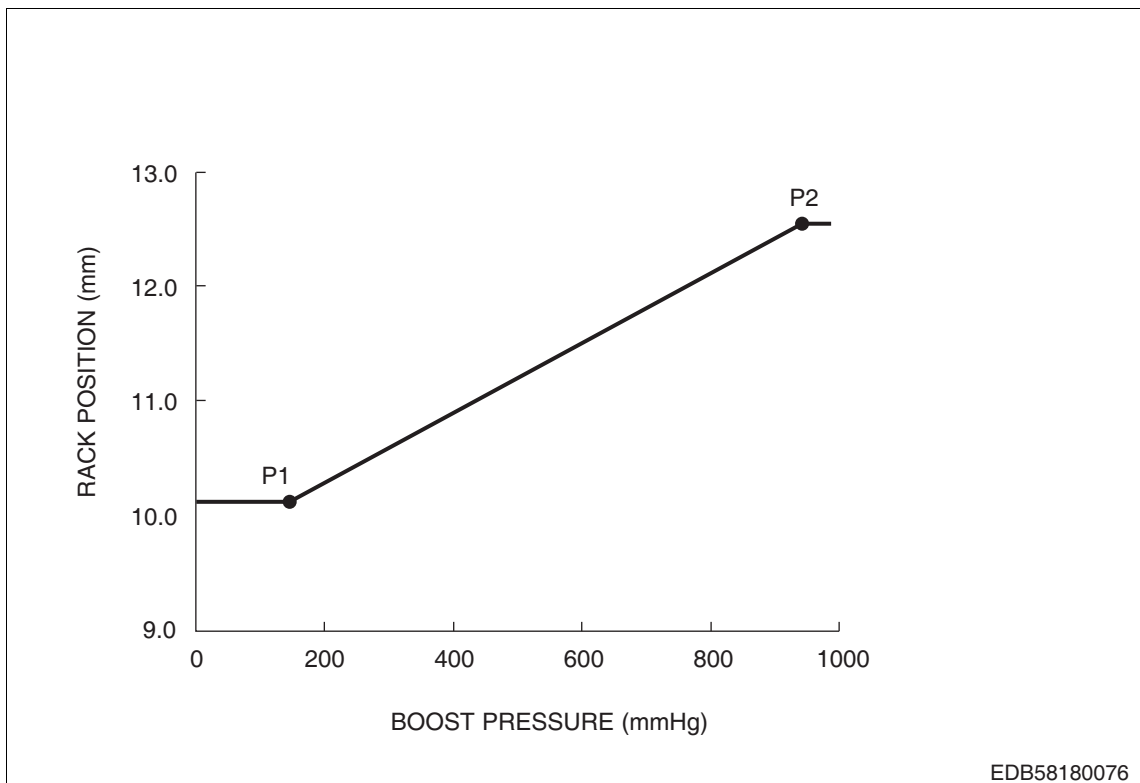

### 7.3.2. Fuel Feed Pump

#### 1) General descriptions and construction

The P-type injection pump is mounted with NP-FP or KD-PS type feed pump. These pumps have the same basic construction and operation, and the general descriptions of the KD type pump are given below:

The figures show its construction (right figure) and operation (below figure). The piston in the fuel feed pump is driven by the push rod and tappet via the camshaft of injection pump and performs reciprocating operation to control the suction and delivery of fuel. When the cam reaches the Bottom Dead Center as shown in the figure, the fuel is drawn in through the check valve on the inlet side.

The fuel pressurized as the cam rotates on flows through the check valve on the outlet side as shown in (B). If the feeding pressure increases abnormally, the spring is compressed, resulting in interrupting further delivery of fuel as shown in (C).

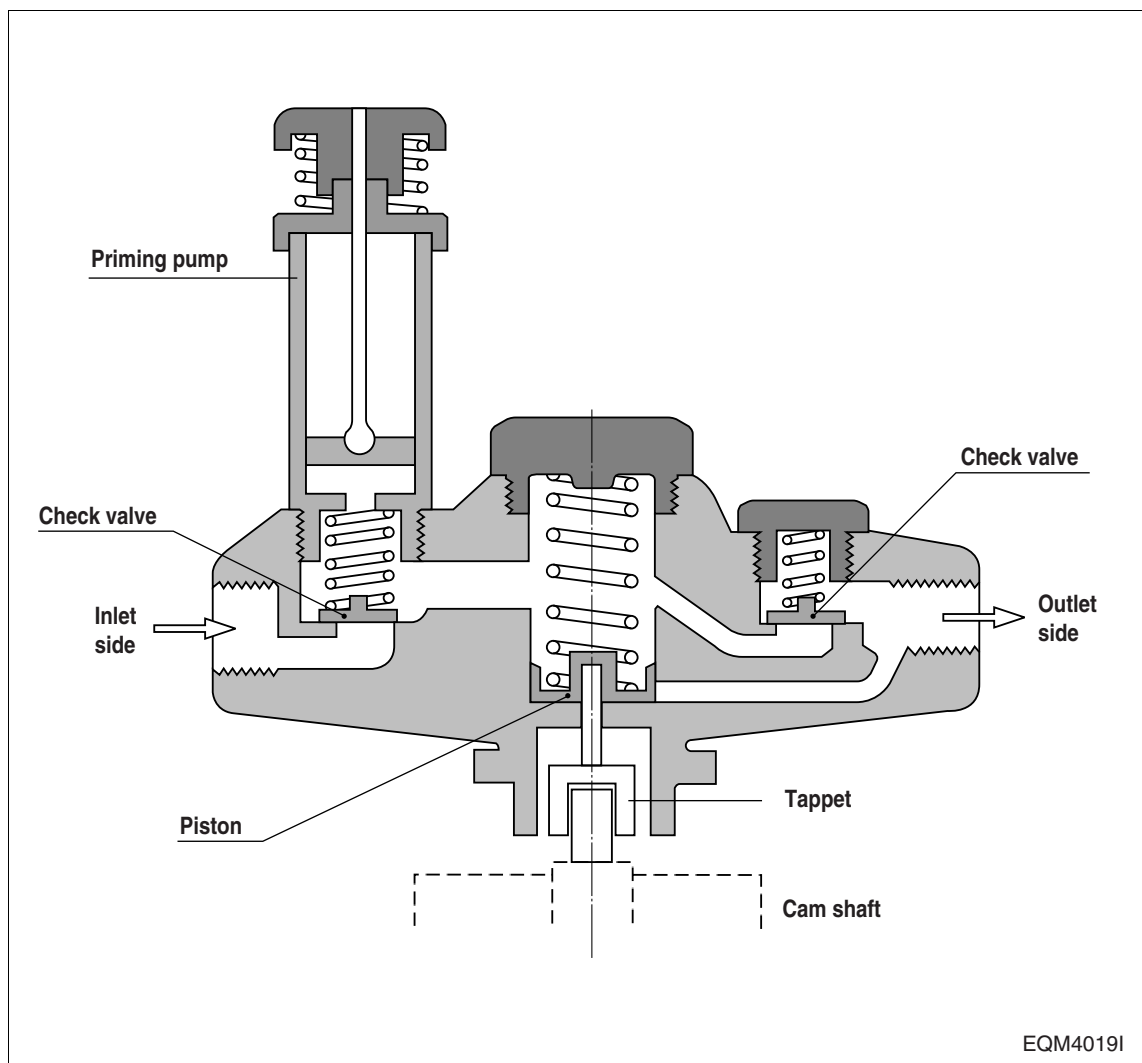

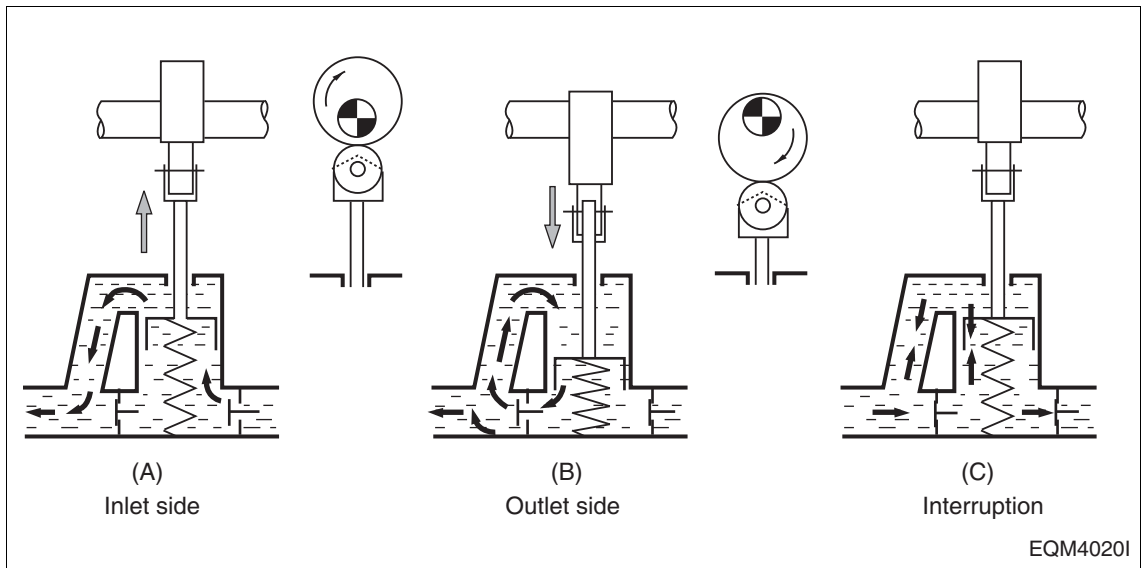

This feed pump is mounted with a priming pump designed to permit manual feeding of fuel from the fuel tank with the injection pump mounted in the engine. During the manual feeding operation, air must be bled from the fuel lines.

When using the priming pump, fix it securely to prevent the possible entry of moisture or other foreign substances in the inside of feed pump.

In addition, a strainer is fitted into joint bolt on the inlet side of the fuel feed pump to filtrate any foreign substances possibly mixed in fuel.

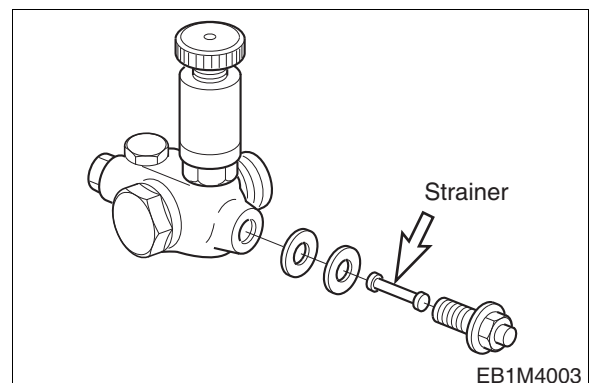

## 2) Disassembly

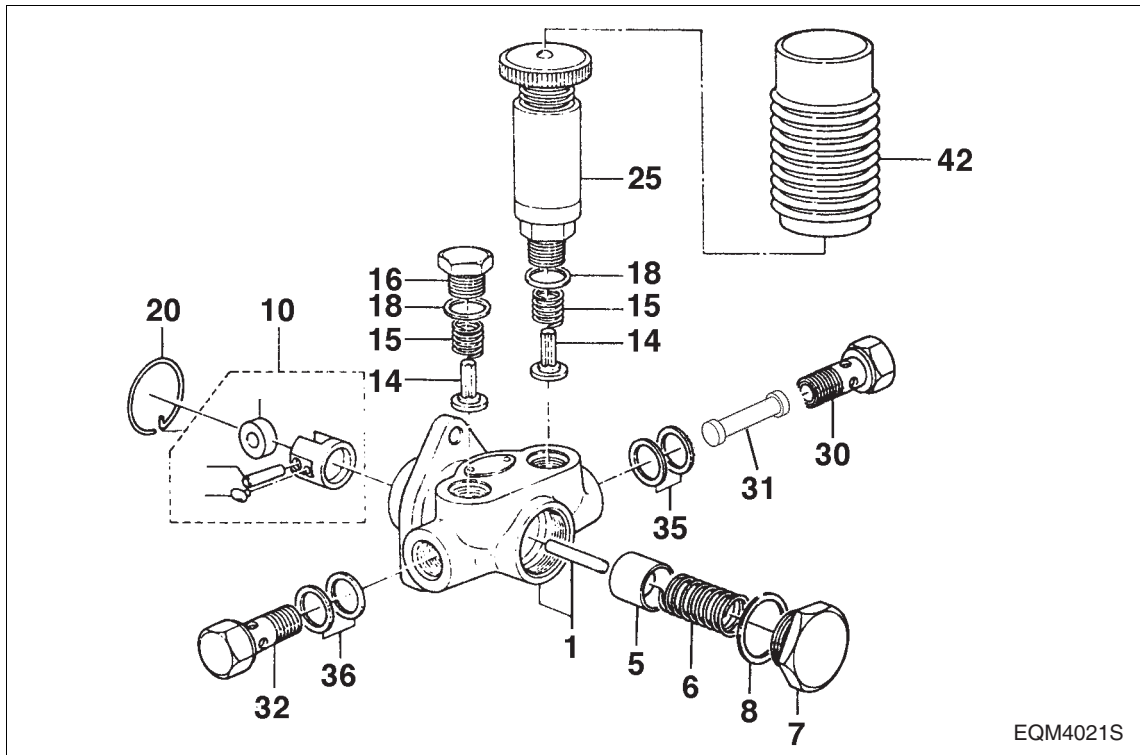

- Clamp the feed pump with a vise and disassemble the plugs (30, 32), strainer (31) and gaskets (35, 36).
  - Take off the priming pump (25), plug (16), both gaskets (18), spring (15), and check valve (14).
  - Take off the plug (7), gasket (8), spring (6), and piston (5) on the piston side.
  - Pull out the snap ring (20) holding the tappet (10).
  - Disassemble the snap ring, then take off the tappet (10) and push rod (1).
- ## 3) Inspection
- If the check valve is damaged or scored on its seat face, replace it with a new one.
  - Inspect the piston and tappet for damage.
  - Replace the push rod if excessively worn, and replace together with the pump housing if required. The inspection for wear should be performed in the same procedure as for suction pressure test described below.
- ## 4) Re-assembly
- Re-assembly operation is performed in reverse order of disassembly. All the gaskets must be replaced with new ones at re-assembly.

## 5) Testing

### (1) Suction capacity test

Connect one end of a hose to the inlet side of the feed pump and immerse the other end of it into the fuel tank as illustrated. Hold the feed pump in position about 1 m above the level of fuel in the fuel tank. Operate the tappet at the rate of 100 rpm and check to see if fuel is drawn in and delivered for 40 seconds or so.

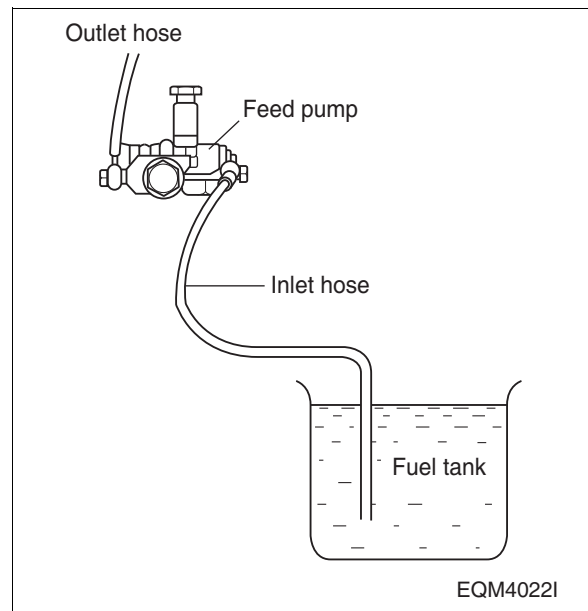

### (2) Delivery test

Make a test with the feed pump mounted on a pump tester as illustrated. Operate the pump at the rate of 1,000 rpm and check to see if the pump delivery is more than 405 cc/15 seconds.

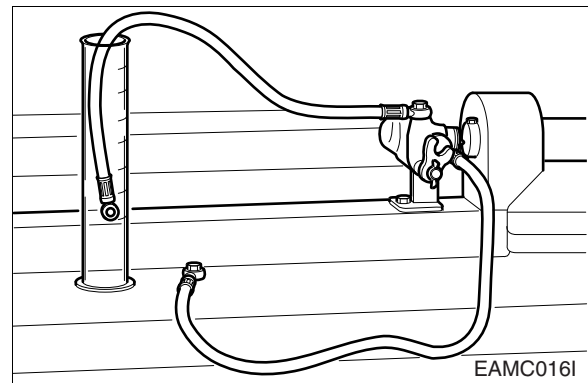

### (3) Sealing test

Plug up the delivery port on the feed pump and apply compressed air of 2 kg/cm<sup>2</sup> into the inlet side.

Submerge the feed pump in a container of diesel fuel and check for air leak.

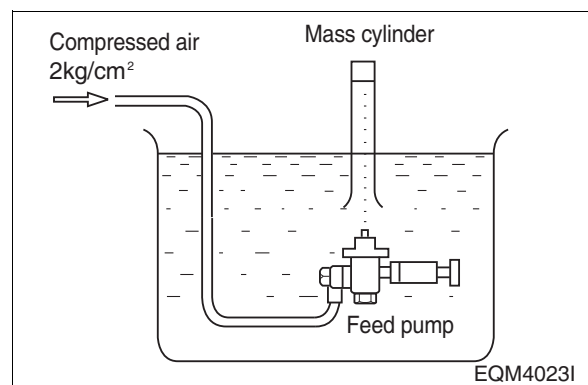

### 7.3.3. Fuel Injection Nozzle

The injection nozzle assembly consists of the nozzle body and needle valve assembly.

Pressurized fuel delivered from the fuel injection pump is sprayed into the combustion chamber past the injection nozzle at proper spray pressure and spray angle, then burnt completely to achieve effective engine performance.

The fuel injected should necessarily be ignited immediately and combusted in a short period of time as too long a combustion period will prevent the high speed operation of the engine and can cause serious engine knocking.

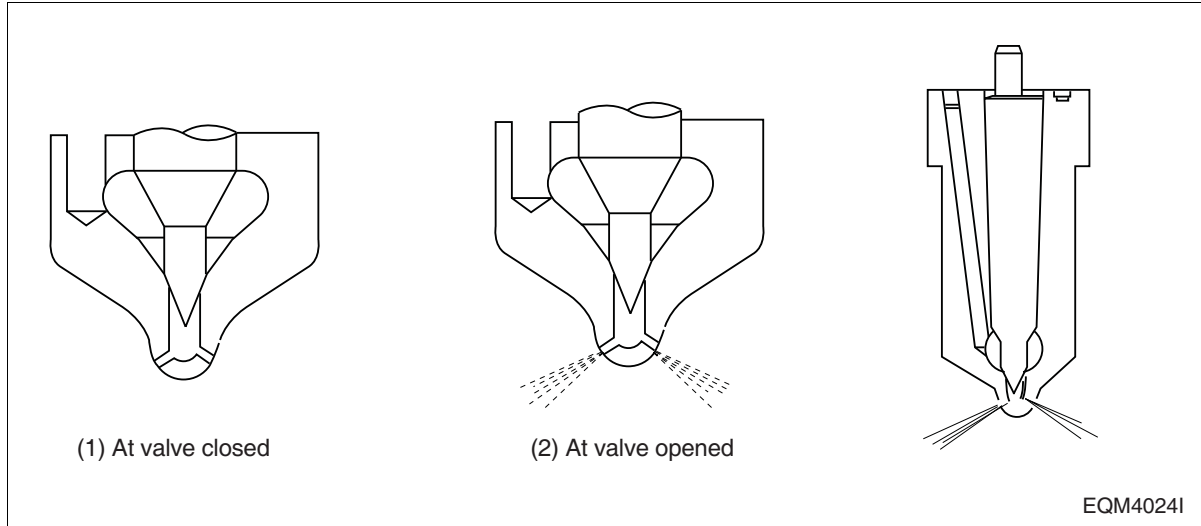

#### 1) Construction

- (1) Nozzle holder
- (2) Union nut
- (3) Shim
- (4) Coil spring
- (5) Guide bush
- (6) Intermediate washer
- (7) Nozzle nut
- (8) Nozzle

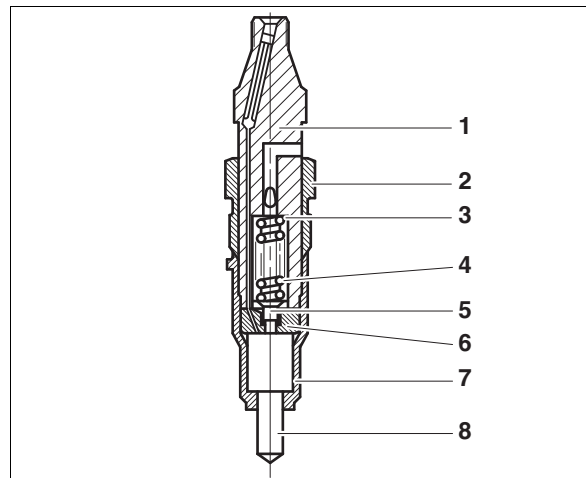

#### 2) Maintenance

Exercise extreme care when handling the injection nozzle assembly, particularly nozzle body and needle valve as these parts are ultra precisely finished.

Wash clean the injection nozzle and remove it from the engine prior to disassembling.

## 1) Disassembly



- Clamp the nozzle holder in a vise and remove the cap nut.
- Loosen the adjust screw lock nut and remove the adjust screw then detach the spring and push-rod
- Clamp the nozzle holder body with the nozzle side up in a vise.
- With a wrench remove the nozzle nut using care not to drop the nozzle. Remove the nozzle carefully not to drop the needle valve.

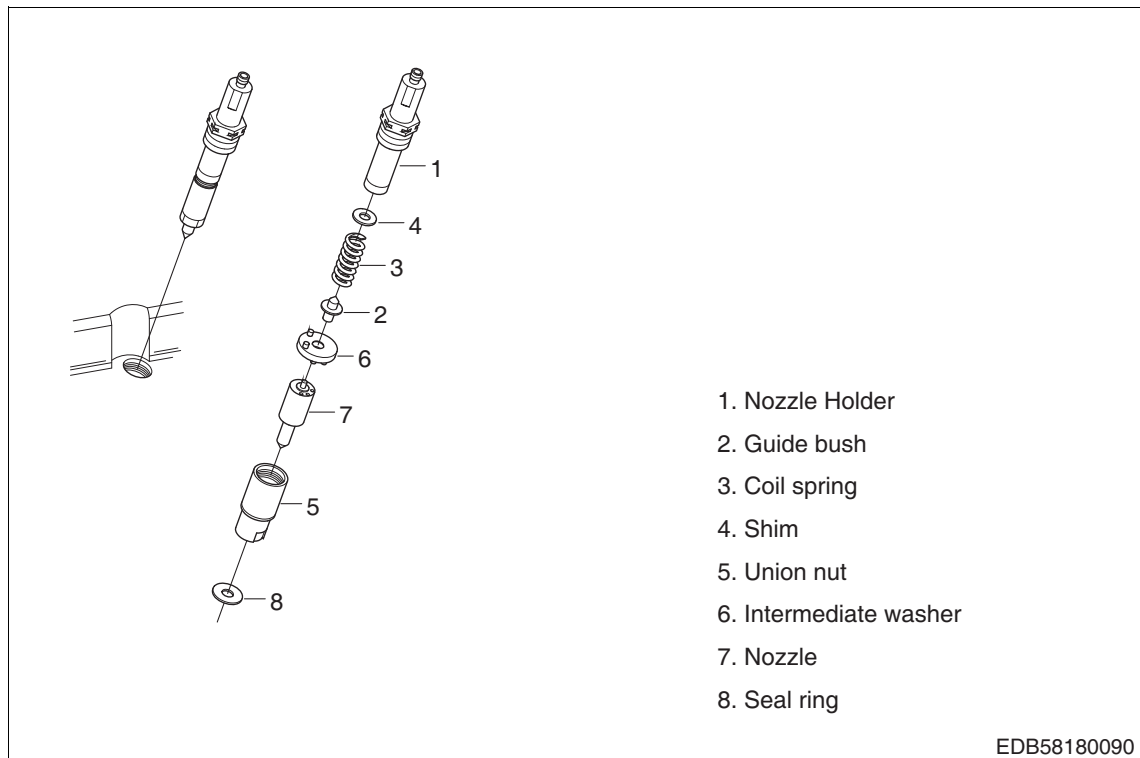

- Visual inspection



After washing, check the injection nozzles against the following:

- a) Needle valves

Check the valve seats, guide shafts and injection shaft for damage.

- b) Nozzle body

Check the valve seats for carbon deposit and damage. Also check the injection orifices for uneven wear.

Replace both of the parts by using assembly even if either of the needle valve or the nozzle body is found to be defective.

- Sliding test

A sliding test should be made on the entire injection nozzle often visual inspection.

Hold the nozzle body vertically and pull the needle valve upward about 1/3 of its entire length and release it and see if it lowers onto its seat by its own weight.

If lowering of the needle valve is not smooth, check for presence of foreign matter and repeat the test. If the trouble persists, replace the entire nozzle assembly with a new one.

## 2) Adjustment

- Remove the cap nut and assemble a nozzle to a nozzle tester.
- With the adjusting screw loosened, operate the nozzle 2 ~ 3 times to bleed it.
- Operate the nozzle tester lever at the specified rate.
- Adjust the injection pressure to the standard pressure using the adjusting screw.
- After adjusting the injection pressure, tighten the cap nut to specified torque.
- Re-check the injection pressure and see if the spray pattern is normal. Spray pattern should be uniform and free of spattering.

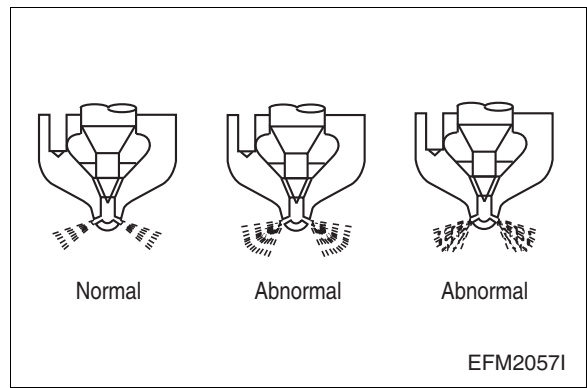
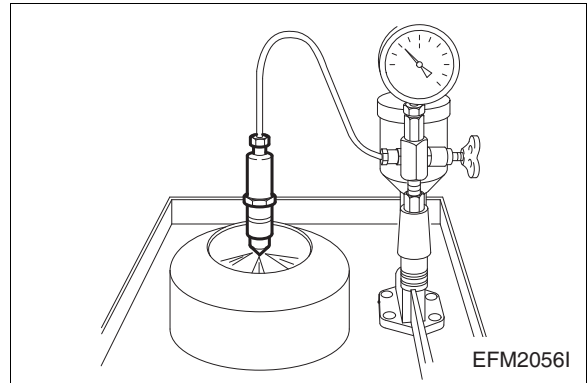

## 3) Testing

With the nozzle assembled to a nozzle tester and specified pressure applied, check the nozzle for fuel leakage.

Model	L136/T/TI/086TI	L086TIL
Opening pressure	214 + 8 kg/cm <sup>2</sup>	257 ±7 kg/cm <sup>2</sup>

If the joints are free from leaks and the needle valve is working normally, the operation of the nozzle will be accompanied by whistling sound.

Adjust the standard pressure by means of the spring adjusting screw.

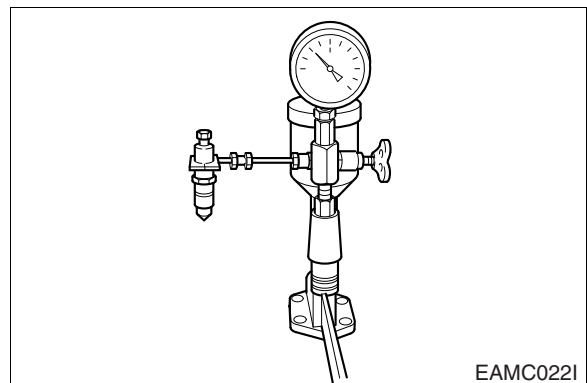

#### 4) Re-assembly



- After removing carbon deposit, submerge the nozzle in diesel oil and clean it.
- Replace all the gaskets with new ones.
- Assemble the parts and tighten them to specified torque.

Items	Torque (kg·m)
Nozzle holder cap nut	7
Nozzle cap nut	6 ~ 8
Injection pipe cap nut	2.9 ~ 3.2
Injection pump delivery valve holder	2.5 ~ 3.0

### 7.4. Turbocharger

The turbocharger is a system designed to make use of the engine exhaust gas energy to charge high-density compressed air into the cylinders, thereby to increase the engine output.

As explained, the compressing of air to supply into the cylinders is called "Supercharging" and the making use of the energy of exhaust gas discharged from the combustion chamber to charge the compressed air into the cylinders is called "Turbocharging".

#### 7.4.1. Specification

##### 1) Main data and specifications

Sepecification		L136T/TI	L086TIH	L086TIM
Turbocharger Model		T04E55	HX35	
At maximum output	Air pressure at compressor	About 1.2 kg/cm <sup>2</sup>	About 1.24 kg/cm <sup>2</sup>	About 1.44 kg/cm <sup>2</sup>
	Air suction volume	About 19.0 m <sup>3</sup> /min	About 15.4 m <sup>3</sup> /min	About 18.6 m <sup>3</sup> /min
	Speed of turbine revolution	About 100,000 rpm	About 83,000 rpm	About 83,000 rpm
Maximum allowable speed		130,000 rpm	130,000 rpm	
Max. allowable temperature of exhaust gas at turbine inlet		750°C	700°C	
Lubricating system		→	External oil supply	
Weight		10 kg	21 kg	

## 7.4.2. Turbo Charger Assembly

1) L136T / TI: TO4E55

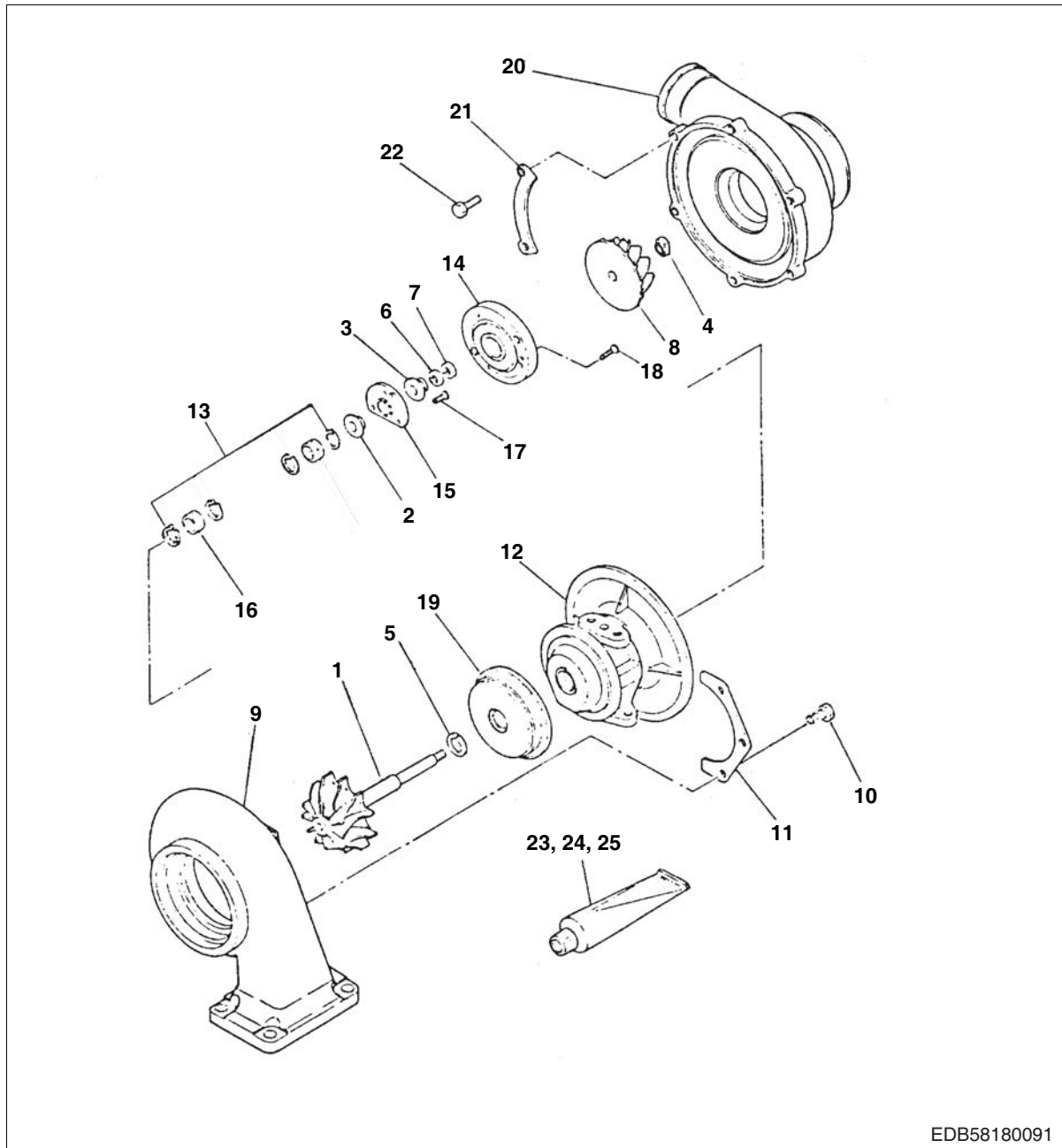

EDB58180091

- |                    |                     |                            |
|--------------------|---------------------|----------------------------|
| 1. Turbine shaft   | 10. Bolt            | 19. Heat plate             |
| 2. Thrust bush     | 11. Clamp           | 20. Compressor housing     |
| 3. Oil shut off    | 12. Bearing housing | 21. Clamp                  |
| 4. Lock nut        | 13. Retainer ring   | 22. Bolt                   |
| 5. Seal ring       | 14. Seal plate      | 23. Liquid gasket          |
| 6. Seal ring       | 15. Thrust bearing  | 24. Loctite                |
| 7. Seal ring       | 16. Journal bearing | 25. Liquid anti-burn agent |
| 8. Compressor seal | 17. Screw           |                            |
| 9. Turbine housing | 18. Screw           |                            |

2) L086TI (HX35)

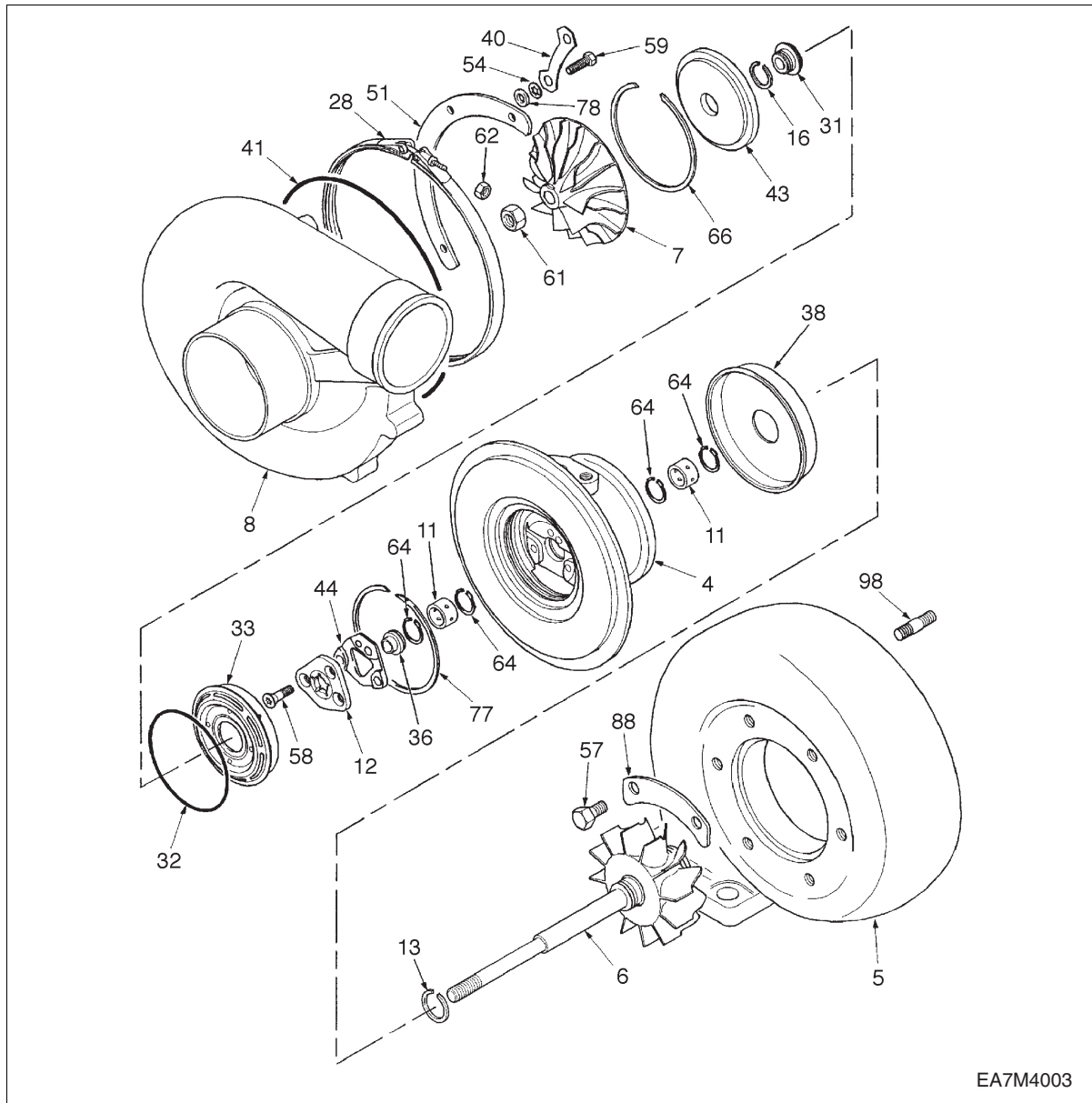

- |                                     |                                   |                                |
|-------------------------------------|-----------------------------------|--------------------------------|
| 2. Center housing rotating assembly | 31. Oil slinger                   | 57. Bolt, turbine housing      |
| 4. Bearing housing                  | 32. O-ring seal, bearing housing  | 58. Screw thrust bearing       |
| 5. Turbine housing                  | 33. Oil baffle                    | 59. Bolt compressor cover      |
| 6. Assembly turbine wheel           | 36. Thrust collar                 | 61. Lock nut, compressor wheel |
| 7. Compressor wheel                 | 38. Heat shield                   | 62. V-band lock nut            |
| 8. Compressor housing               | 40. Lock plate compressor         | 64. Ring retainer bearing      |
| 11. Journal bearing                 | 41. O-ring seal, compressor       | 66. Insert, retaining ring     |
| 12. Thrust bearing                  | 43. Oil seal plate                | 77. Flat retaining ring        |
| 13. Piston ring seal, turbine       | 44. Thrust bearing spacer         | 78. Washer, compressor         |
| 16. Piston ring seal, compressor    | 51. Clamp plate, compressor cover | 88. Clamp plate, turbine       |
| 29. V-band clamp                    | 54. Lock washer, compressor       |                                |

### 7.4.3. Inspection

As the condition of turbocharger depends greatly on how well the engine is serviced, it is very important to maintain the engine in accordance with the specified maintenance procedure and pay particular attention to checking oil & air leaks, unusual sound on running.

1) Checking of the rotor for rotating condition

The inspection of the rotor assembly for rotating condition should be performed by the degree of unusual sound on running. If a sound detecting bar is used, install its tip on the turbocharger housing and increase the engine revolutions slowly. If a high-pitch sound is heard every 2~3 seconds or continuously, it means that the rotor assembly is not normal.

In this case, as the metal bearing and rotor are likely to be in abnormal conditions, the turbocharger should be replaced or repaired.

2) Checking of the rotor end play

The radial and axial clearances of the rotor should check after every 2,000 hours operation.

This precaution will enable measuring for any wear of axial clearance bearings to be detected in good time before serious damage is caused to the rotor and bearings. Disassemble the turbocharger from the engine, then check the rotor axial play and radial play.

- (1) When disassembling the turbocharger, be sure to plug the oil inlet and outlet ports
- (2) If the measured axial and radial plays are beyond the limit of wear, replace or repair the turbocharger.

- Measuring rotor axial clearance

<b>Radial Clearance</b>	0.12 mm
-------------------------	---------

- Measuring radial clearance

<b>Radial Clearance</b>	0.58 mm
-------------------------	---------

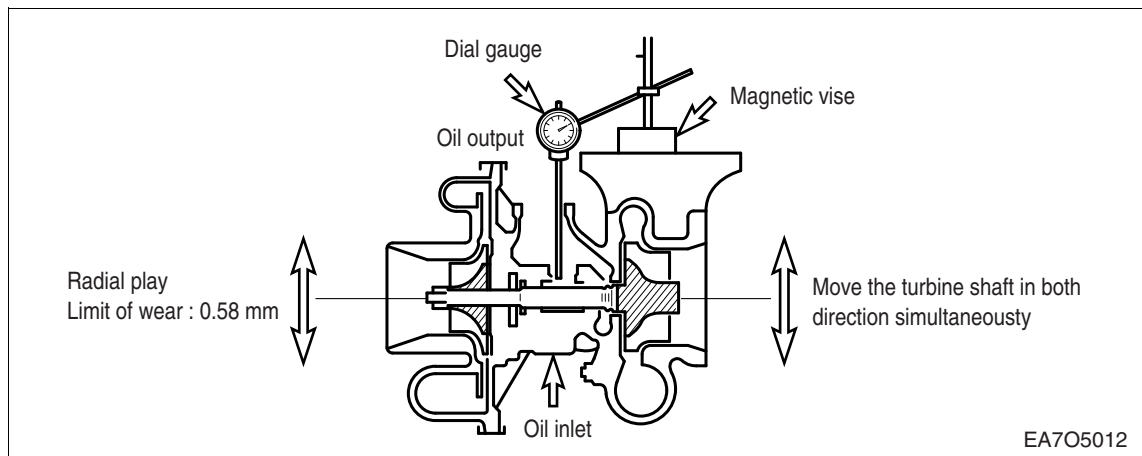
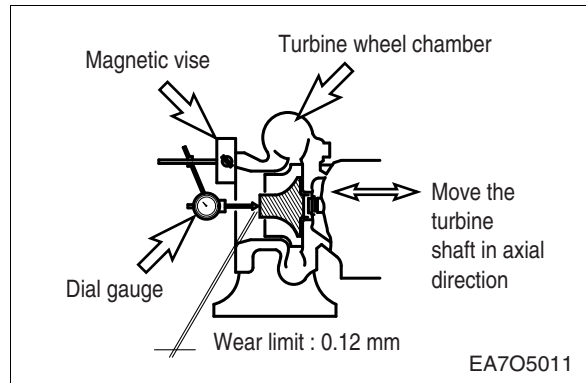

### 3) Precautions for reassembling the turbocharger onto the engine

For re-assembly of the turbocharger or handling it after re-assembly operation, be sure to observe the following precautions: Especially, pay attention to prevent foreign matters from entering the inside of the turbocharger.

#### (1) Lubricating system

- Before reassembling the turbocharger onto the engine, inject new oil in the oil inlet port and lubricate the journal and thrust bearings by rotating them with hand.
- Clean not only the pipes installed between the engine and oil inlet port but also the oil outlet pipe and check them for damage or foreign matters.
- Assemble each joint on oil pipes securely to prevent oil leaks.

#### (2) Intake system

- Check the inside of the intake system for foreign matters.
- Assemble each joint on the intake duct and air cleaner securely to prevent air leaks.

#### (3) Exhaust system

- Check the inside of the exhaust system for foreign matters.
- Be sure to use heat resisting steel bolts and nuts. Do not interchange them with ordinary steel bolts and nuts when performing re-assembly operation. Apply anti-seizure coating to the bolts and nuts.
- Assemble each joint on the exhaust pipes securely to prevent gas leaks.

## 7.4.4. Maintenance

### 1) Component identification

- Turbocharge identification

A dateplate is fitted to the compressor housing (8). The information on this dateplate must be quoted for service and parts support.

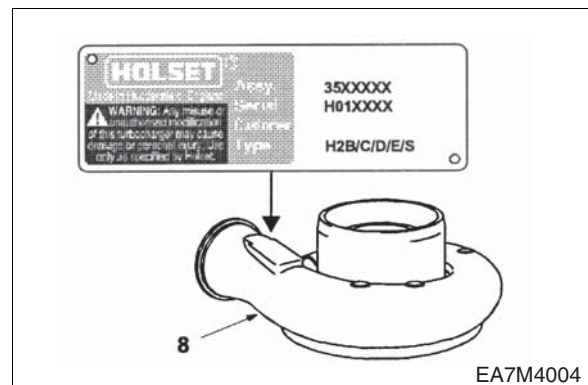

- Center housing rotating assembly (H2D).

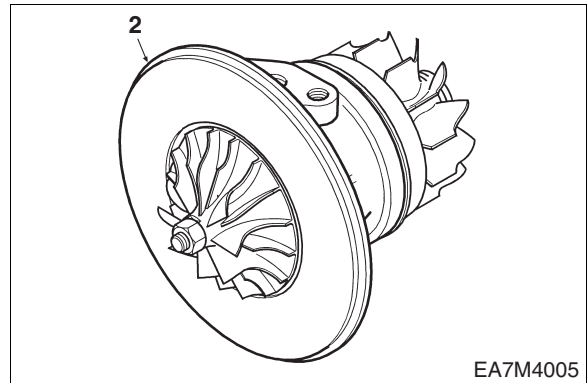

- Watercooled bearing housing (5).  
This can have additional water feed drain plug fittings. Special attention should be made to the position of these fittings as this may be specific for each application.

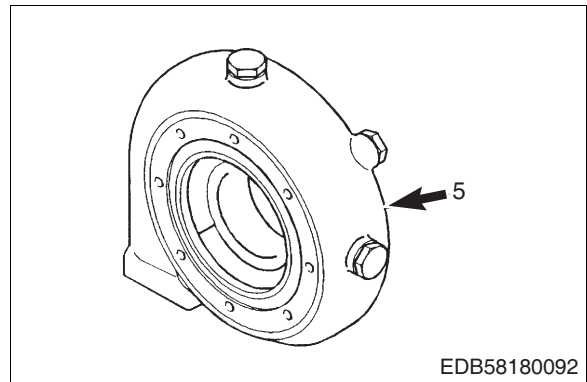

## 2) Disassembly

- Before disassembling the turbocharger, scribe the parts listed below to help in alignment during assembly.

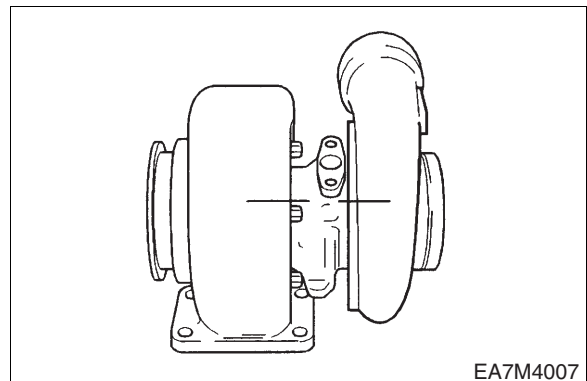

- Secure the turbine housing (5) in a vice. Loosen and remove the 8 bolts (59) lock washers (54) clamp plates (51).

Loosen and remove the compressor side V-band lock nut (62).

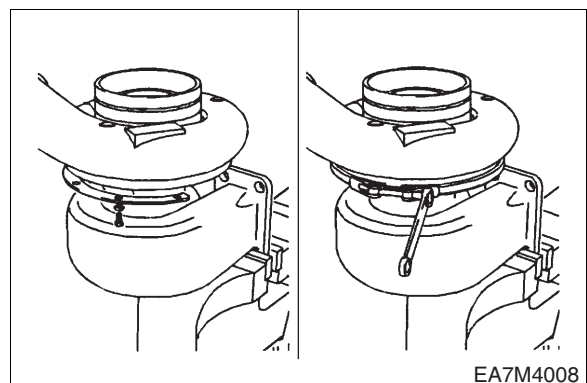

- Gently remove the compressor cover (8), and fitted, remove the O-ring seal (41).



**CAUTION:** *The compressor wheel blades can be easily damaged when the compressor housing is removed.*

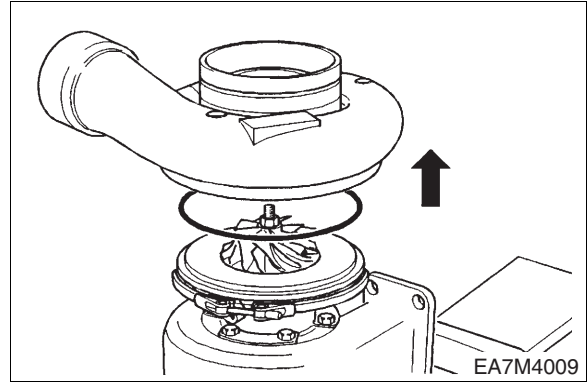

- Loosen and remove the 6 bolts (57) and clamp plates (88).

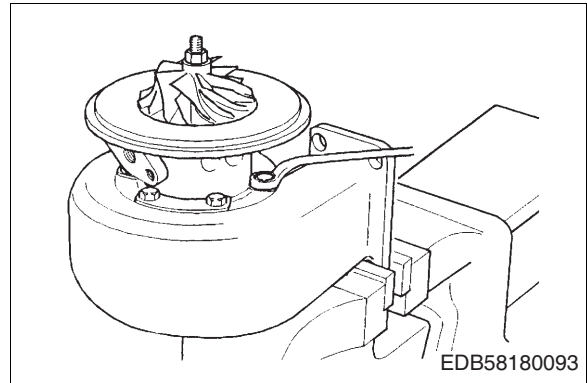

**CAUTION:** *The turbine blades can be easily damaged when the turbine housing is removed.*

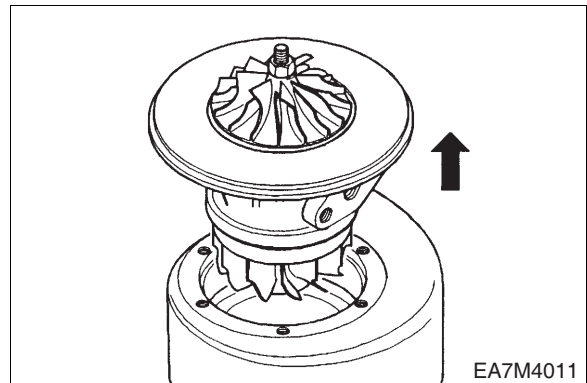

- Locate the center housing rotating assembly (CHRA) onto a 19 mm socket clamped in the jaws of a vice or a suitable fixture.



**CAUTION:** *Always make sure the turbine wheel shaft and the compressor wheel have alignment marks before disassembly of the CHRA.*

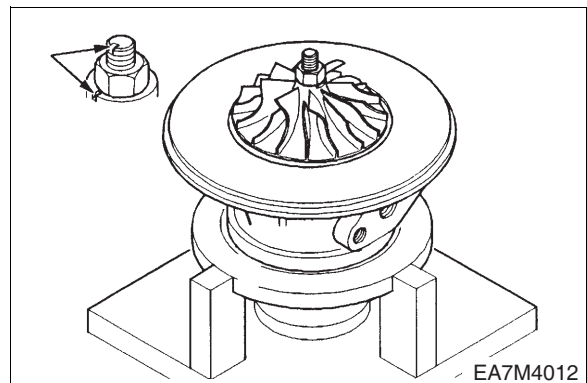

- Remove the compressor wheel lock nut (61).



**NOTE:** *Left hand thread.*

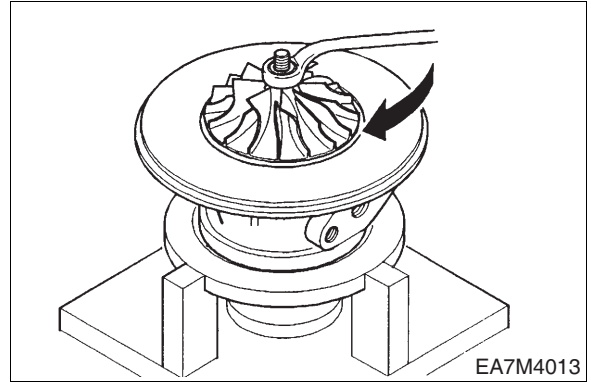

- Remove the compressor wheel (7).

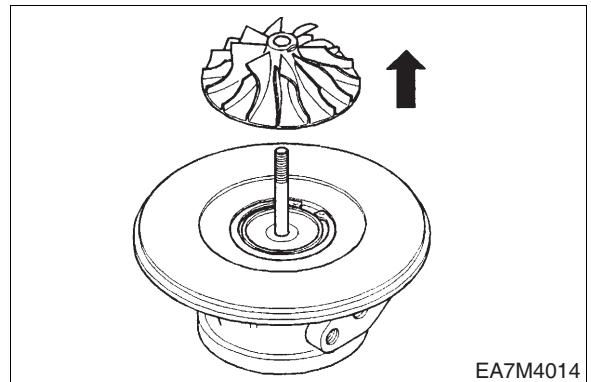

- Remove the remaining CHRA from the socket and gently slide the shaft and wheel (6) from the bearing housing (4).

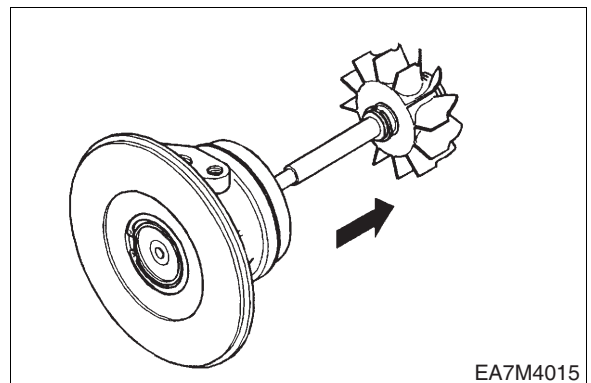

- Discard the two piston ring seals (13).



**CAUTION:** *Care should be taken not to score the assembly turbine wheel shaft.*

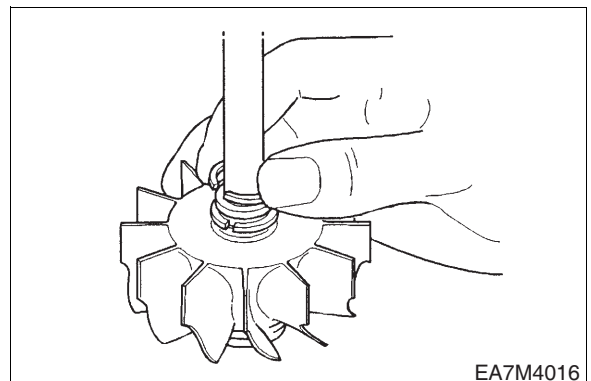

- Remove the heat shield (38).

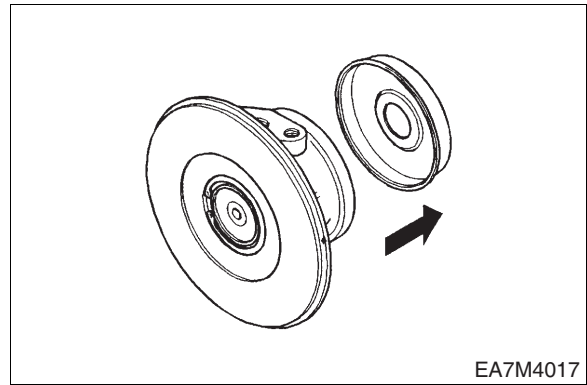

- Place the bearing housing on a flat surface and using a flat screwdriver, remove the insert retaining ring (66).

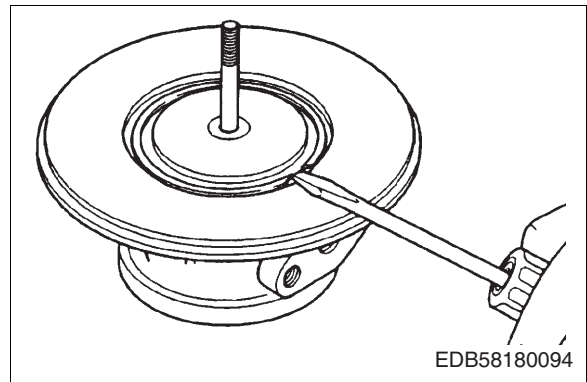

- Using two flat screwdrivers, gently remove the oil seal plate (43).

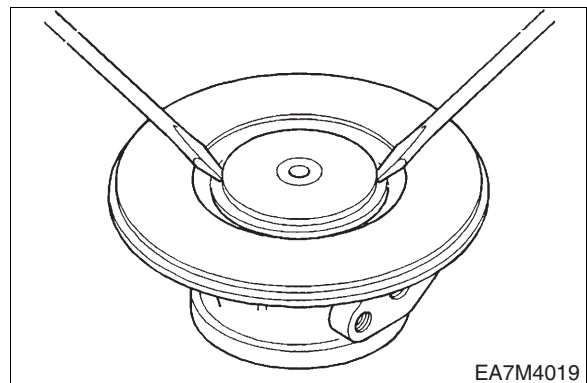

- Remove the oil slinger (31).

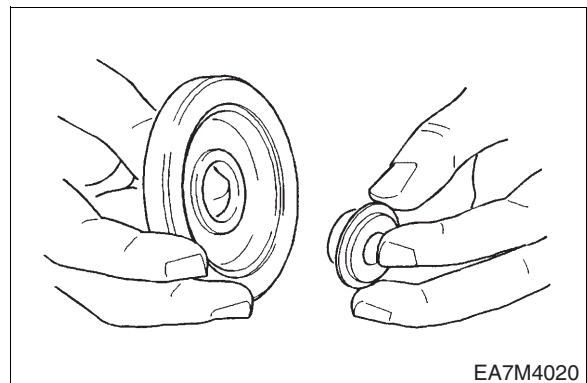

- Remove and discard the piston ring seal (16).

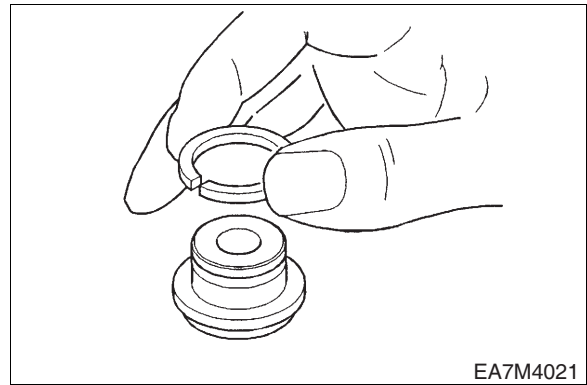

- Remove and discard the O-ring seal (32).

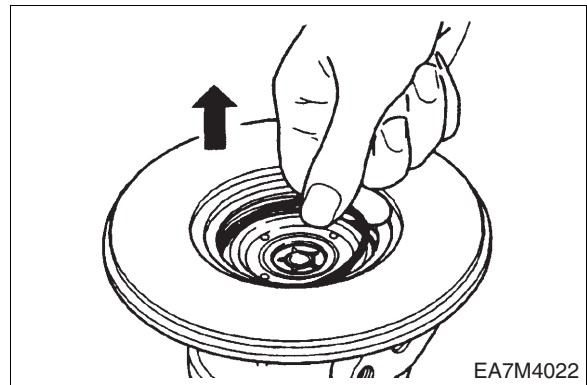

- Remove the oil baffle (33).

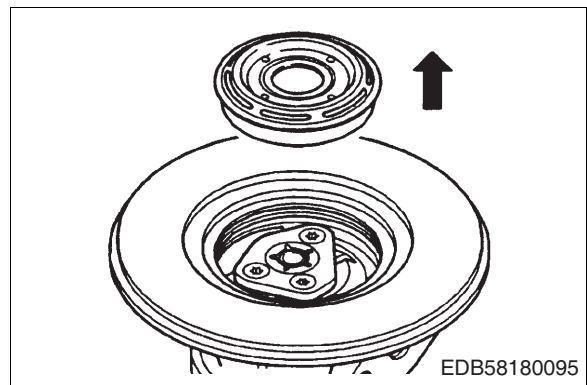

- Remove and discard the 3 flat head screws (58).  
Remove the thrust bearing (12).

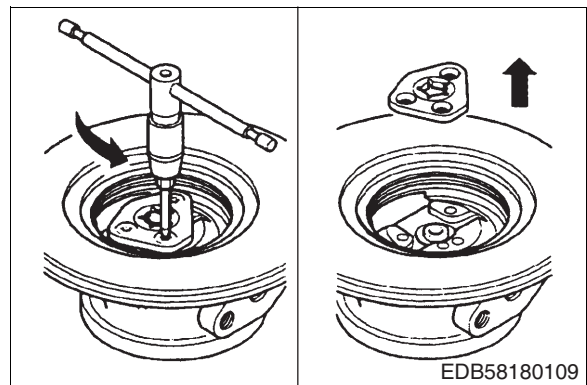

- If fitted remove the thrust bearing spacer (44).

Remove the thrust collar (36). Also remove flat retaining ring (77) if fitted.

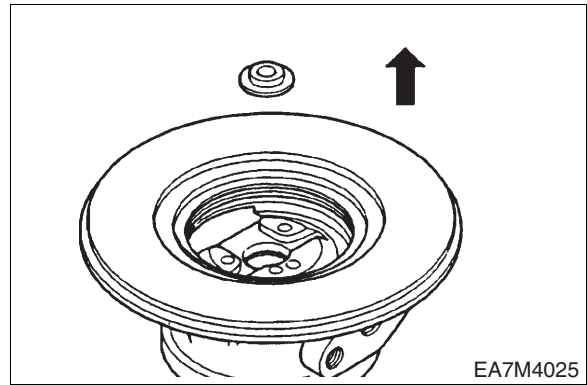

- Using circlip pliers, remove and discard the two circlips (64) and the journal bearing (11) from the compressor end.

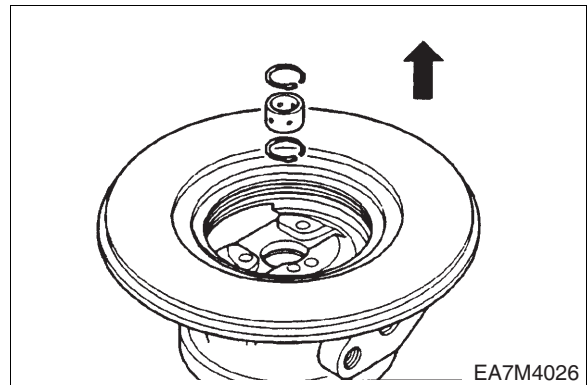

- Turn the bearing housing over and repair the process.

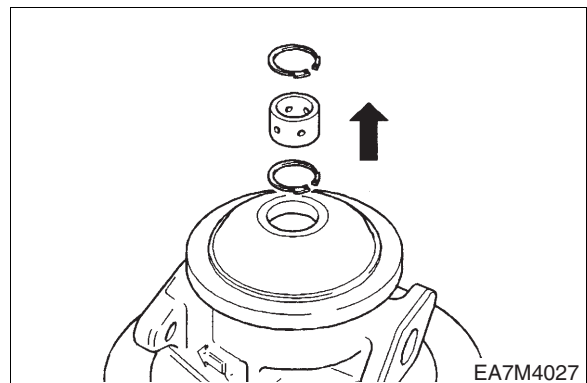

### 3) Cleaning



With the turbocharger completely dismantled for overhaul, soak all the components in a non-caustic metal cleaner to loosen deposits. Bead blast the turbine housing if chemicals do not clean sufficiently.

On aluminium parts a bristle brush can be used. Never use a wire brush or metal scraper on any turbocharger component. Ensure that all the palls are finally cleaned with an air jet, especially drilled passages and machined apertures. Turbine Wheel: In the event of carbon build-up, it may be necessary so carefully blast the Piston Ring Groove area of the turbine wheel using low grade shot medium.



**CAUTION:** Shot blasting specific areas for long periods of time may effect component balance.

The surface adjacent to the turbine and compressor wheels on the stationary housings must be clean, smooth and free from deposits.

4) Inspection



**CAUTION:** Do not attempt to straighten the turbine shaft.

- a) Place the shaft on a vee block, using a dial gauge rotate the turbine wheel and check for movement on the dial gauge. Replace the assembly turbine wheel if it is bent. Max shaft bend allowed 0.025 mm (0.001 ins).

Shaft Bend (Max.)	mm	in.
	0.025	0.001

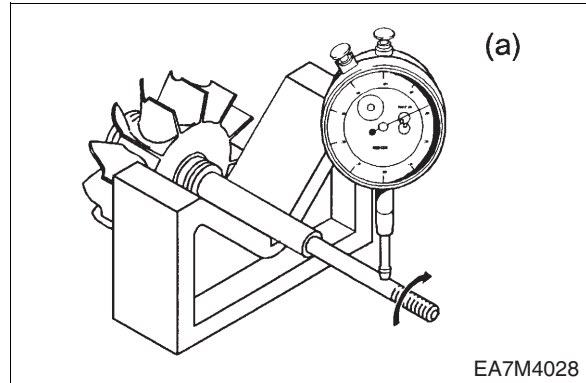

<Major Components>

- Assembly turbine wheel (6).



- b) Inspect the piston ring groove walls for wear.

Turbine Wheel Piston Ring Groove	mm	in.
Single Ring (Min.)	1.664	0.0665
Twin Ring (Min.)	3.538	0.1393

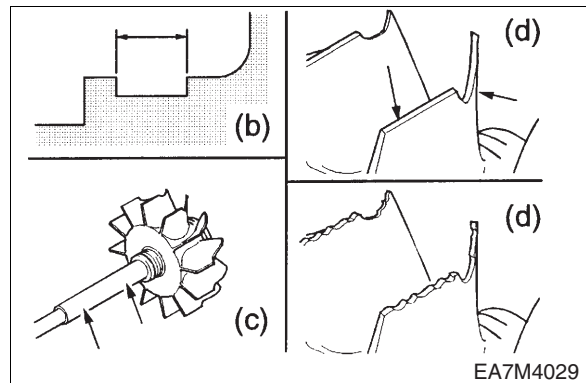

- c) Inspect the bearing journals for excessive scratches and wear. Minor light scratches may be tolerated.

Assembly Turbine Wheel Journals (Min.)	mm	in.
	3.538	0.1393



- d) Inspect for cracked, bent or damaged blades but DO NOT ATTEMPT TO STRAIGHTEN BLADES.



- Turbine Housing (5)

Inspect the profile for damage caused by possible contact with the rotor. Check all threads for damage. Inspect the outer and internal walls for cracks or flaking caused by overheating also check mounting flanges for signs of distortion.

Replace with new if any of the above are visible.

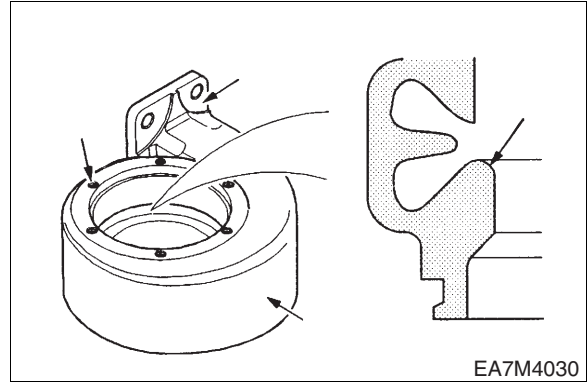

EA7M4030



- Compressor Housing (8)

Inspect the profile for damage due to possible contact with the rotor. Check the V-band groove. Replace with new if any of the above is visible.

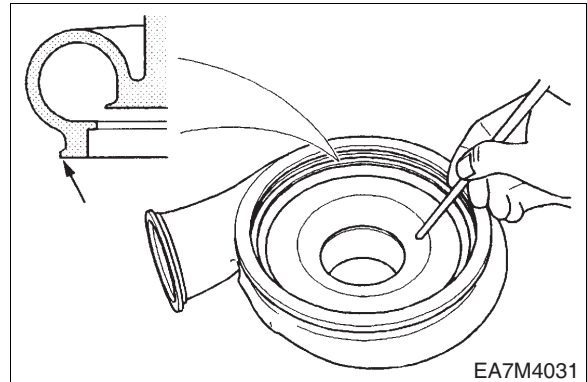

EA7M4031



- Bearing Housing (4)

Inspect the bore for wear or score mark on both the bearing and piston ring area.

Also check all tapped holes are clean and free from dirt.

Replace with new if any damage is found.

Bearing Housing Bore (Max.)	mm	in.
	19.063	0.7505

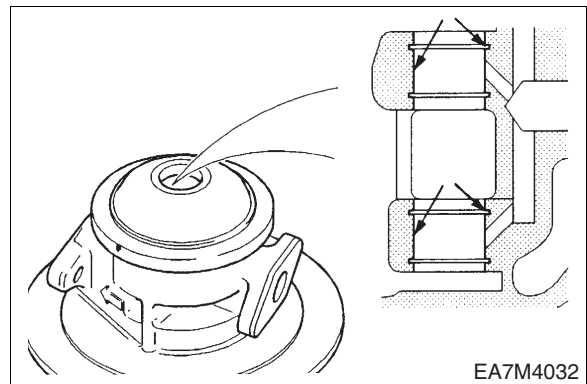

EA7M4032



- Compressor Wheel (7)

Inspect carefully for cracked, bent or damaged blades but DO NOT ATTEMPT TO STRAIGHTEN BLADES.

Replace with new if any damage is found.

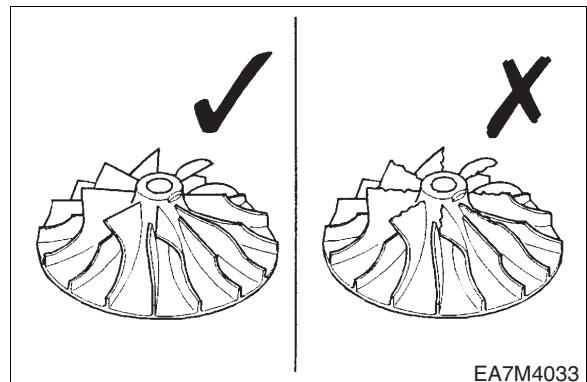

EA7M4033

<Minor Components>

- Oil slinger (31)



Inspect and replace if the piston ring seal groove walls are scored or damaged. Also check for signs of rubbing on the flat surfaces.

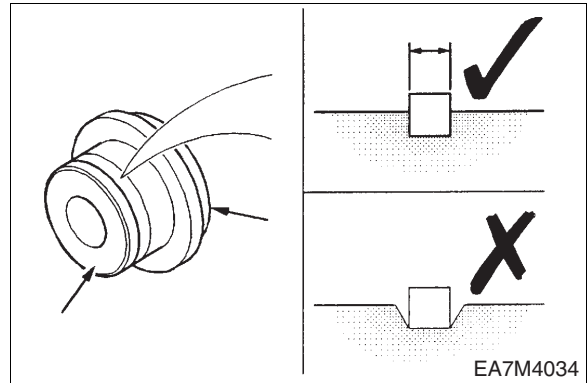

- Oil seal plate (43)



Inspect the seal bore, replace if scored or damaged.

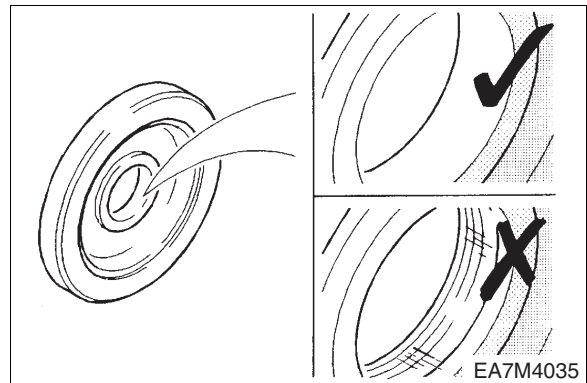

- Heat shield (38)

Check and replace if the heat shield is distorted or if signs of rubbing or cracking are visible.

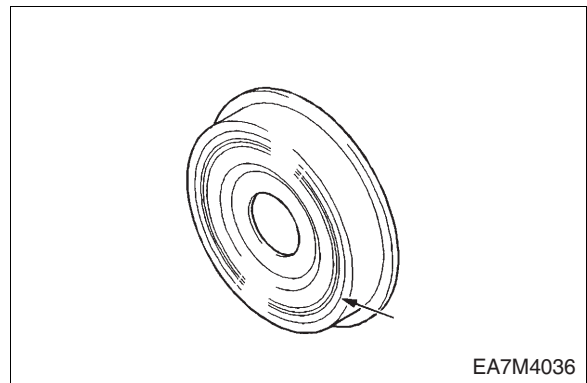

5) Assembly

- Rotor balance



Before assembly, always make sure that both compressor wheel and assembly turbine wheel are individually balanced.



Then check balance of the rotor assembly to ensure it is within the required limits.



Mark up each individual item to help ensure correct alignment during assembly.

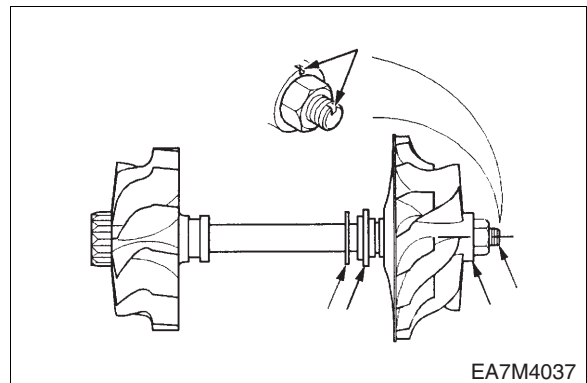

Rotor Balance Limits (Max.)	g.mm	oz. ins.
Turbine End	2.2	0.003
Compressor End	4.4	0.006

- Make sure that the circlips are always fitted with the bevelled edge facing the journal bearing.



**CAUTION:** Circlips (64). Premature failure will result if the circlips are fitted incorrectly.

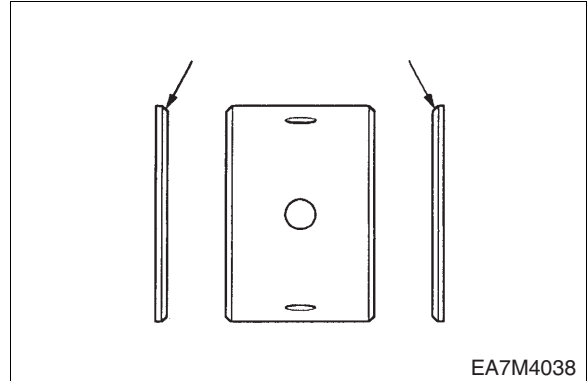

- Place the bearing housing (4) on a bench with the turbine end facing uppermost.

Fit the inner circlip (64) with the bevelled edge facing upwards.

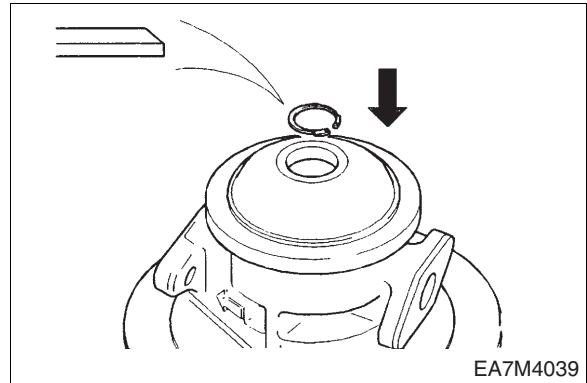

- Lubricate the journal bearing (11) and install into position.

Fit the outer circlip (64) with the bevelled edge facing the bearing.

Turn the bearing housing over and repeat the process.

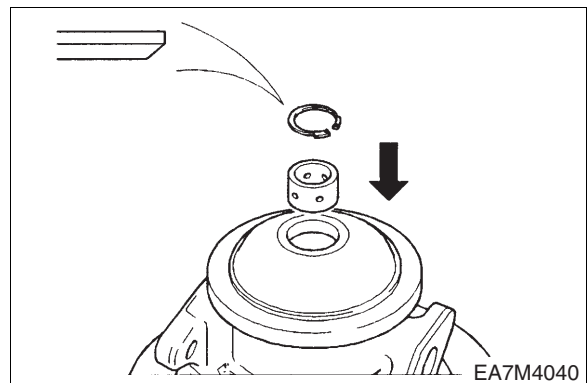

- Install the heat shield (38).

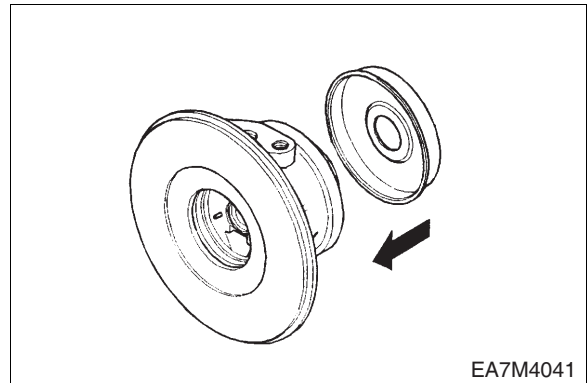

EA7M4041

- Install the two new piston ring seals (13) to the assembly turbine wheel (6).

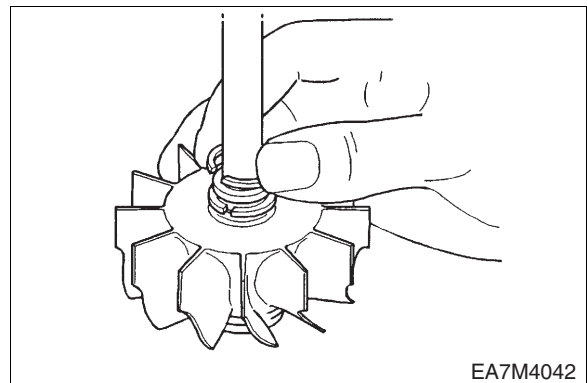

EA7M4042



- Lubricate the shaft using clean engine oil.



**CAUTION:** *Align the piston ring seals (13) so the gaps is positioned 180° from the oil drain hole. Gently press down on the turbine wheel - a slight rotation of the wheel will assist in properly locating the piston ring seals.*

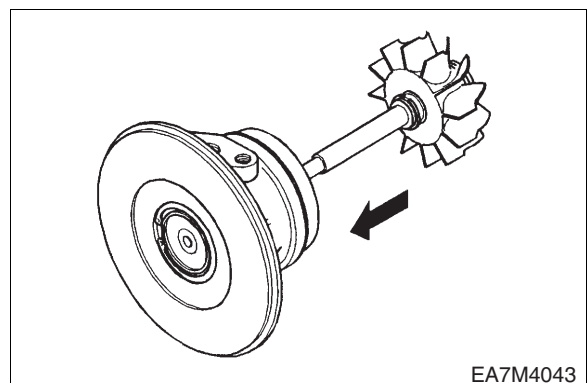

EA7M4043

- Support the assembly turbine wheel (6) and bearing housing in a suitable fixture.

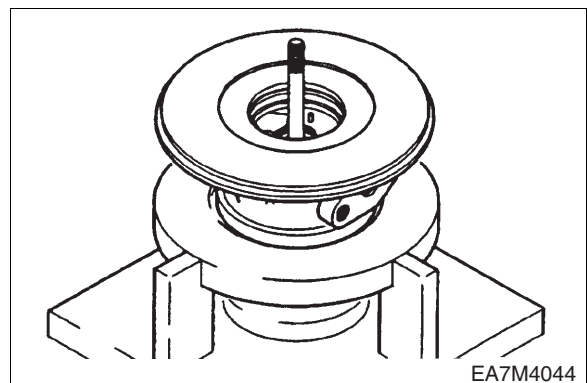

EA7M4044

- Install the thrust bearing spacer (44) if fitted.

Install the thrust collar (36).



**CAUTION:** *Align the balance mark on the thrust collar with that on the shaft.*

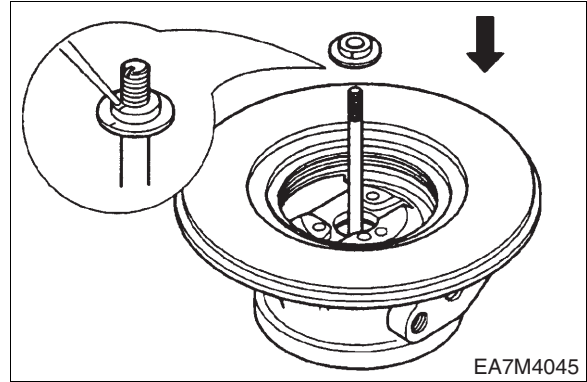

- Using clean engine oil, lubricate the thrust bearing (12).

Install the thrust bearing.

Install the 3 flat head screws (58).



Using torque wrench, tighten to required torque.

Torque Value	Nm	in-lbs
	4.5	40

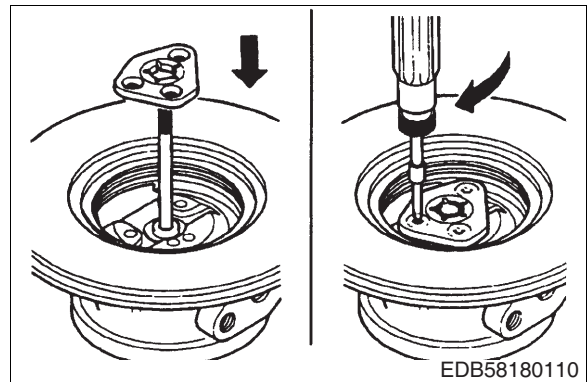

- Fit the new piston ring seal (16) to the oil slinger (31).

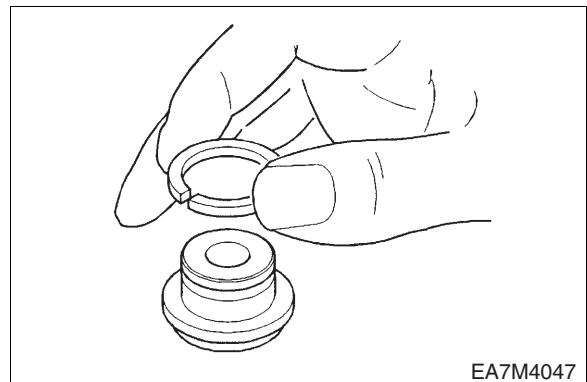

- Fit flat retaining ring (77) in base of bearing housing (4) if required.

Install oil baffle (33).

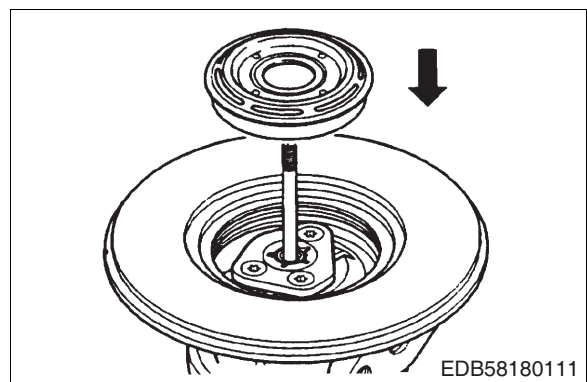



- Apply a small amount of oil to the O-ring seal, install O-ring seal (32).

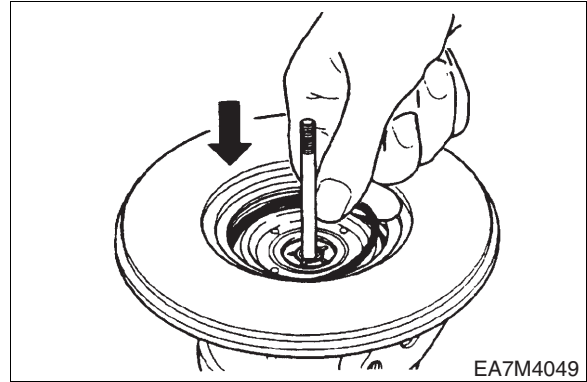

- Insert the oil slinger (31) into the oil seal plate (43).

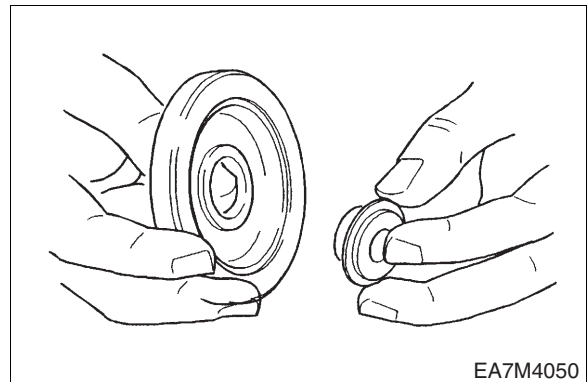

- Install the oil seal plate (43) into the bearing housing (4).



**CAUTION:** *Align the balance marks on the oil slinger (31) with that on the shaft end.*

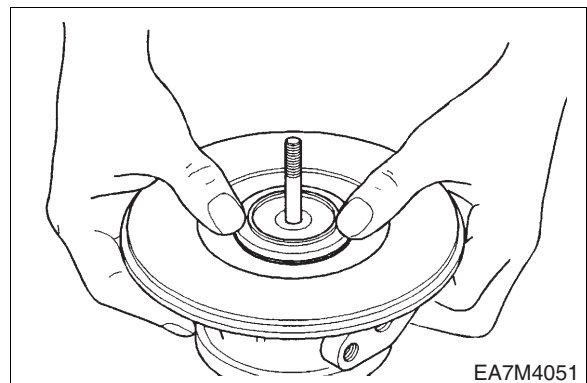

- Gently tap the oil seal plate (43) with a soft hammer to seat in position.

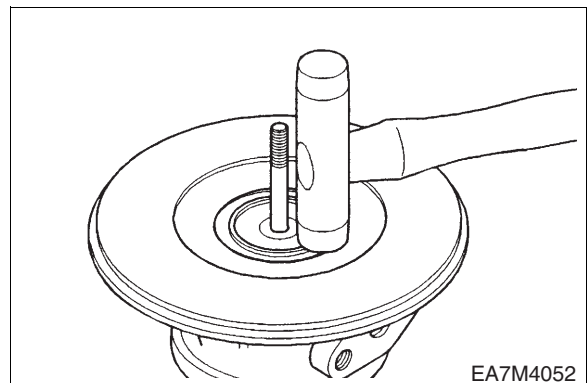

- Install the retaining ring (66).  
Check correct location using a screwdriver.

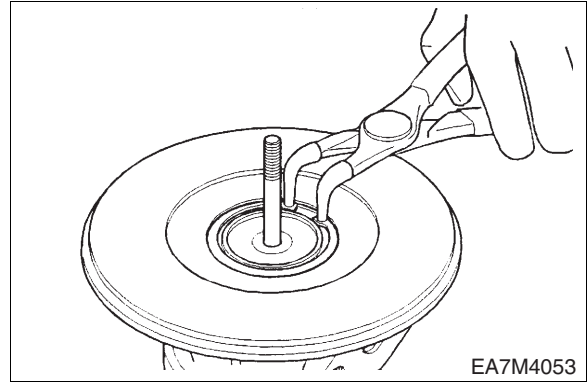

- Align the balance marks and install the compressor wheel (7).

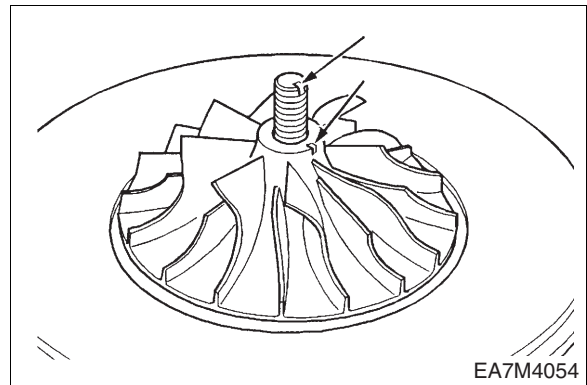

- Install the compressor wheel lock nut (61) and tighten to the torque value.



**NOTE:** *Left hand thread.*

Torque Value	Nm	in-lbs
	17	150



**CAUTION:** *Ensure that the balance marks are aligned on the compressor wheel and the shaft.*

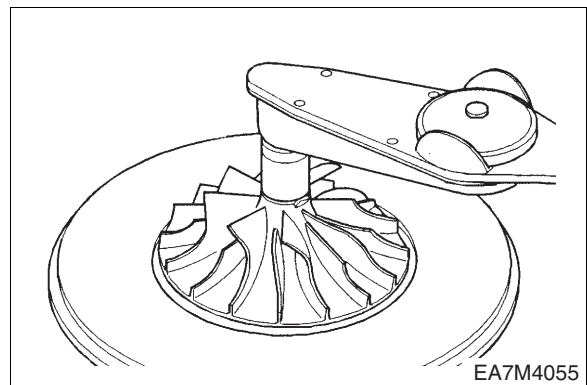



- Locate the CHRA into the turbine housing (5).

Install the 3 clamp plates (88) and tighten the 6 bolts (57) to the torque value.

Torque Value	Nm	in-lbs
<b>Bolts (57)</b>	20	180



**CAUTION:** Make sure the scribe marks are aligned.

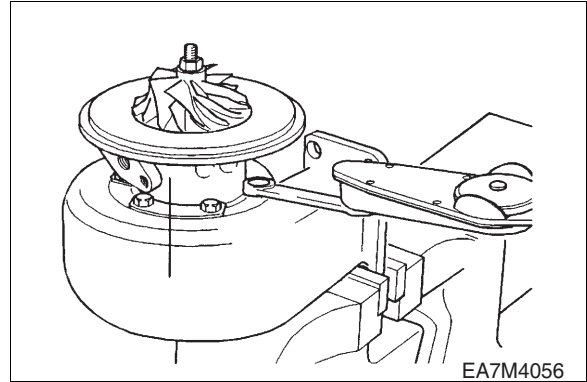

- Secure the turbine housing and check the trust clearance using a dial gauge.

Trust Clearance	mm	in
<b>Minimum</b>	0.038	0.0015
<b>Maximum</b>	0.093	0.0037

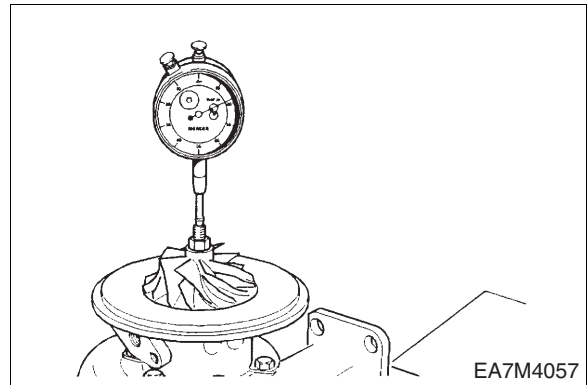

- Check the radial clearance using a dial gauge.

Radial Clearance (H2D)	mm	in
<b>Minimum</b>	0.364	0.014
<b>Maximum</b>	0.550	0.022

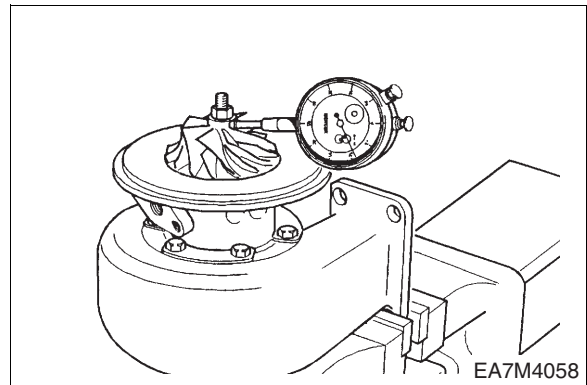

- Loosely fit the V-band clamp.
- Lubricate and install the O-ring seal (41) if fitted.
- Install the compressor cover (8).



**CAUTION:** The compressor wheel blades can be easily damaged when the compressor housing is installed.

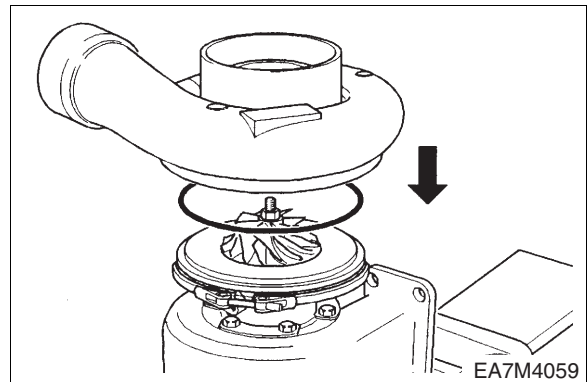



- Install the 2 clamp plates (51), eight lock washers (54) and tighten the 8 bolts (59) to the torque value.

Install the V-band clamp (29) and tighten the lock nut (62) to the torque value.

Trust Value	Nm	in-lbs
Lock Nut (62)	8.5	75
Bolts (57)	8.5	75

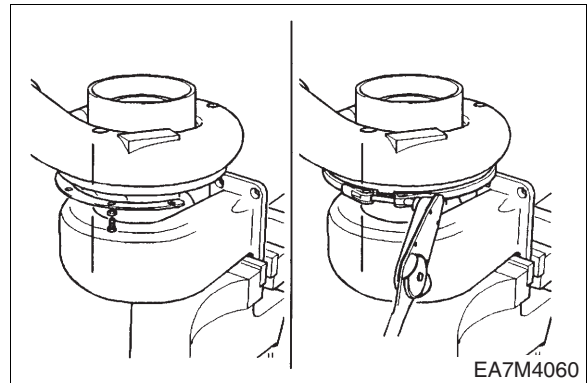

**CAUTION:** Make sure the scribe marks are aligned.



## 8. Trouble Shooting

The following description summarizes the probable cause of and remedy for general failure by item. Immediate countermeasures should be taken before a failure is inflamed if any symptom is detected.

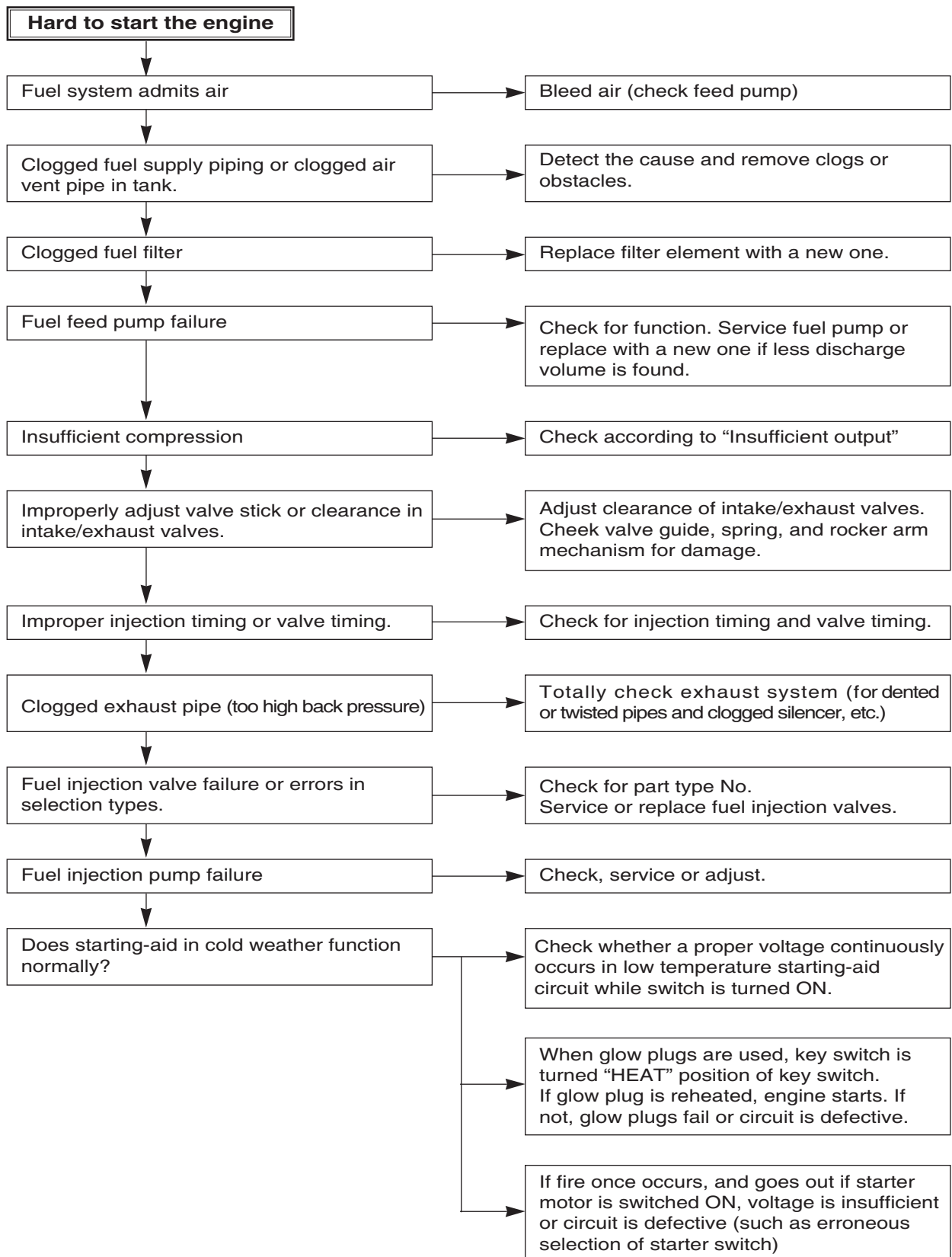

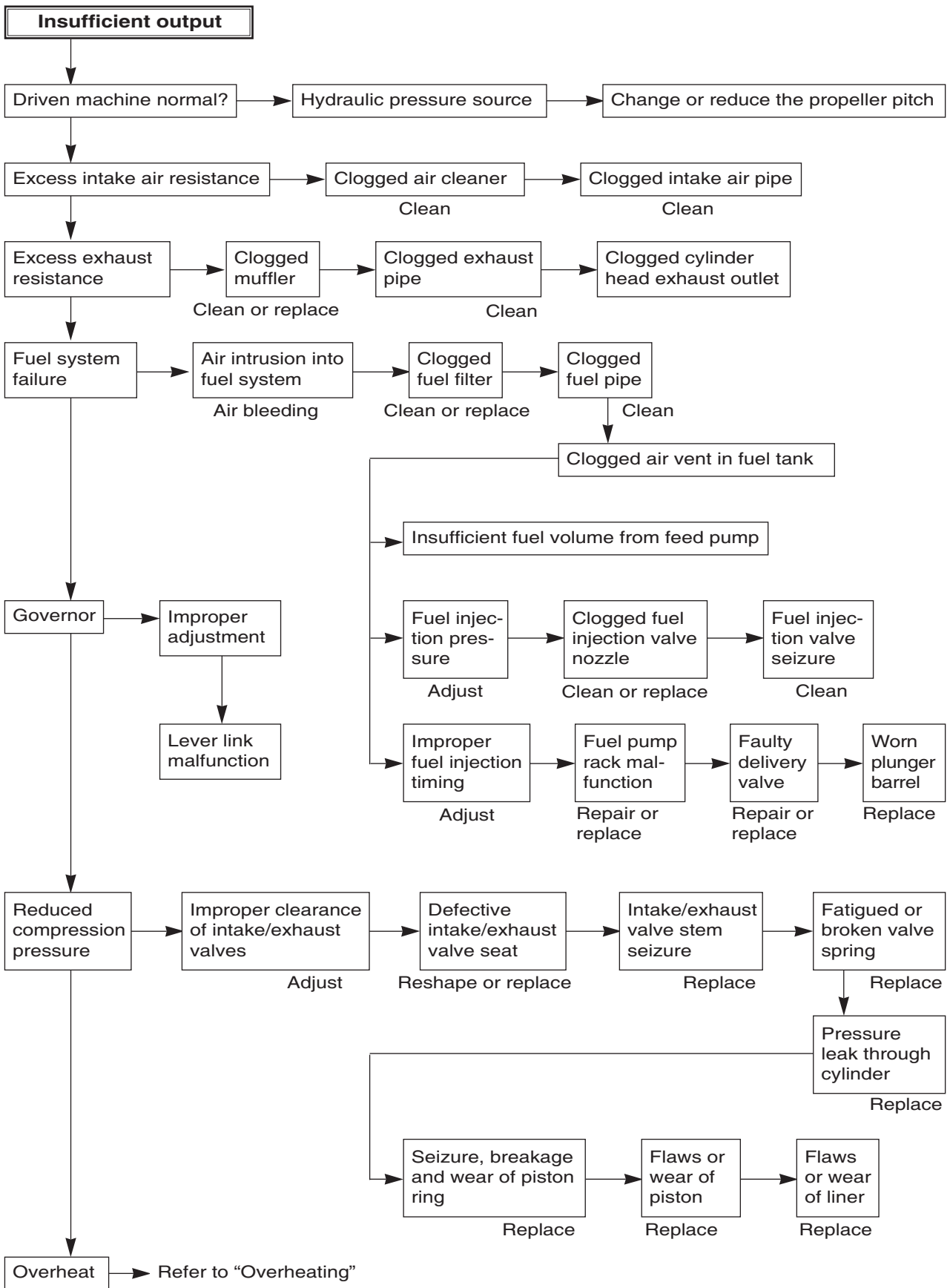

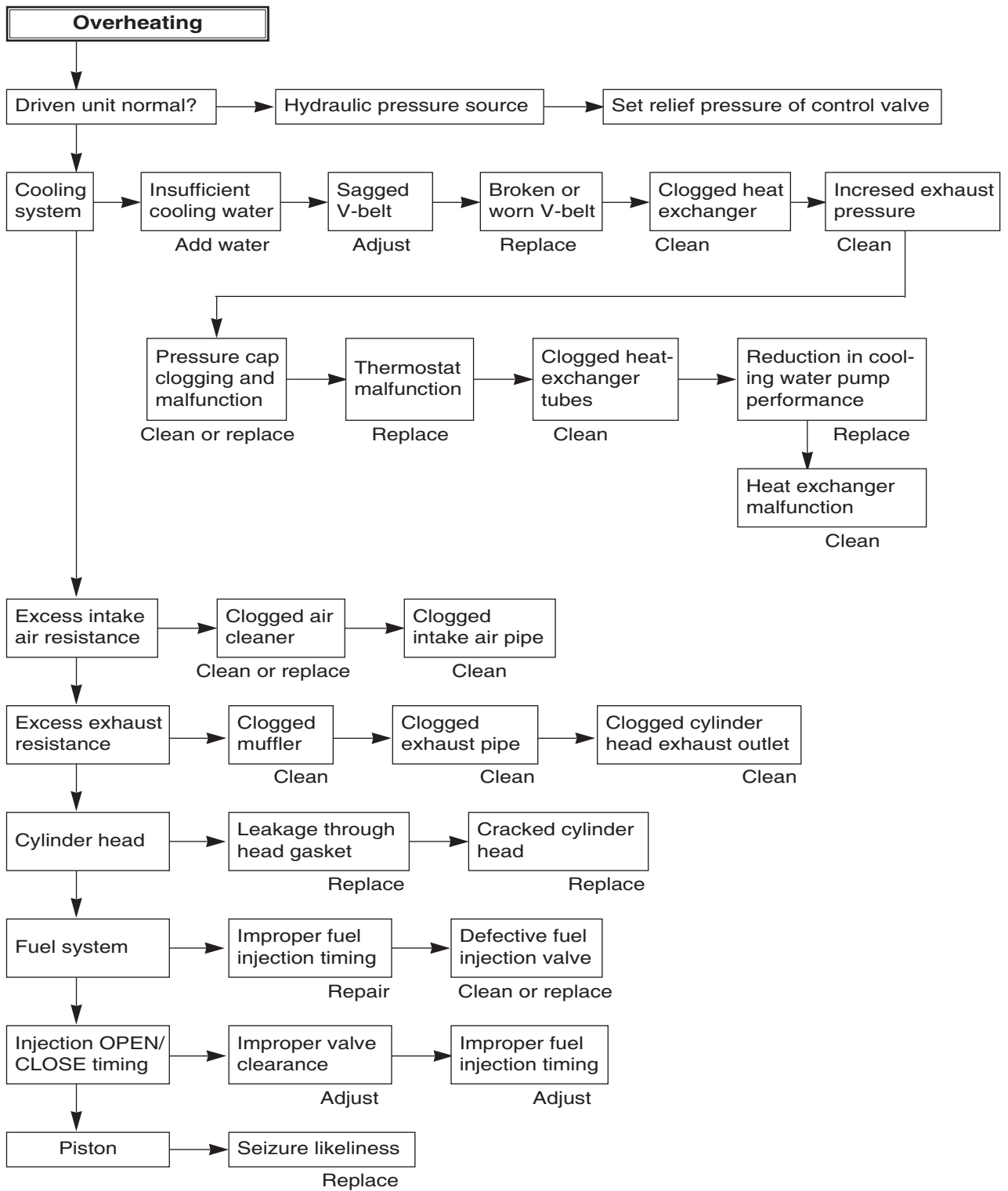

**Black smoke is produced.**

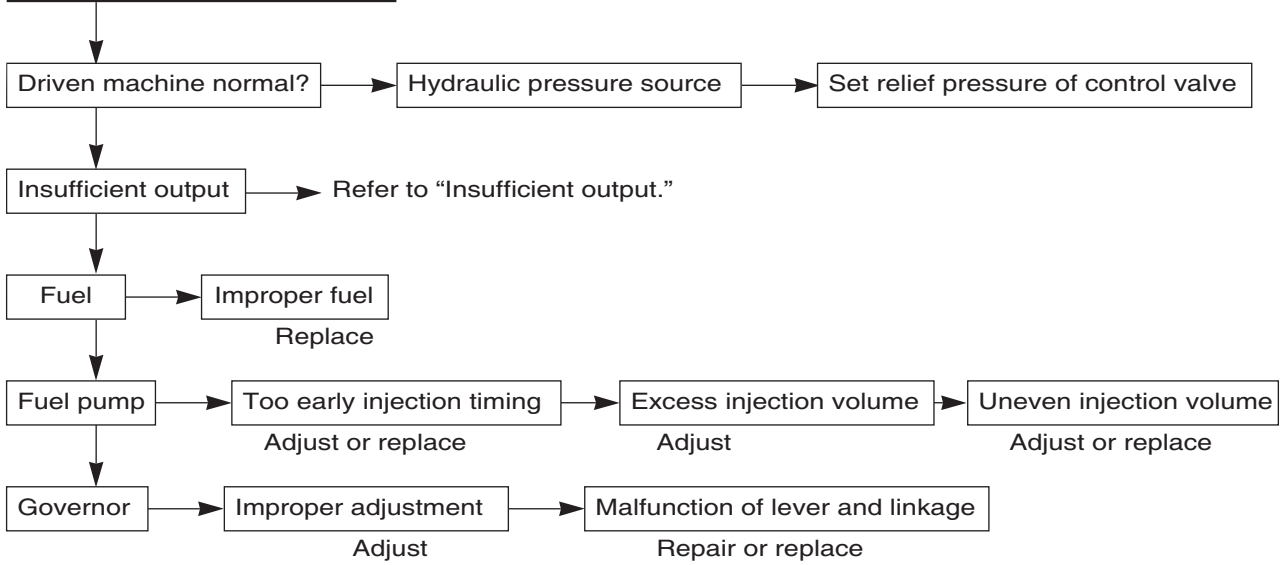

**White smoke is produced.**

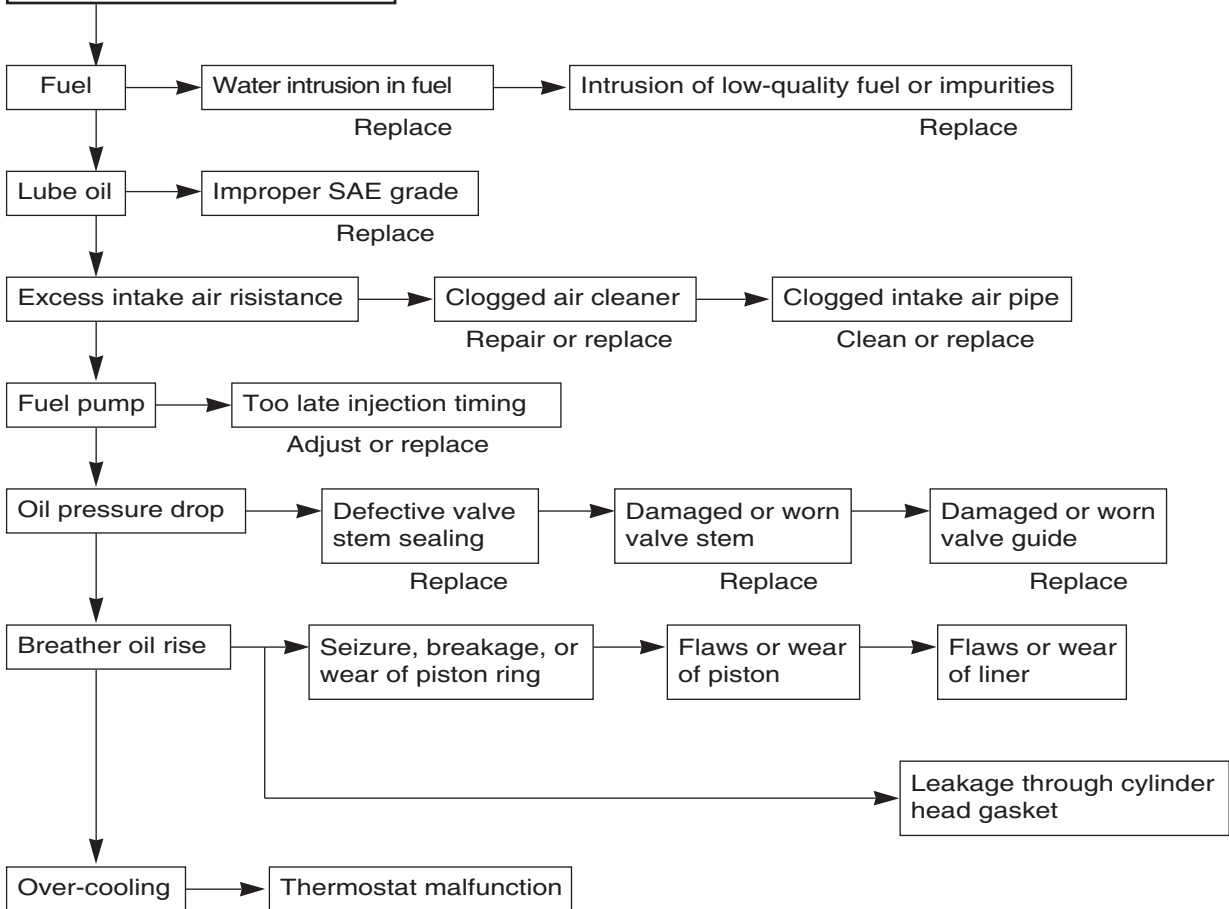

**Starter motor will not turn or output less power.**

[ Except engine seizure and trouble of driven machine ]

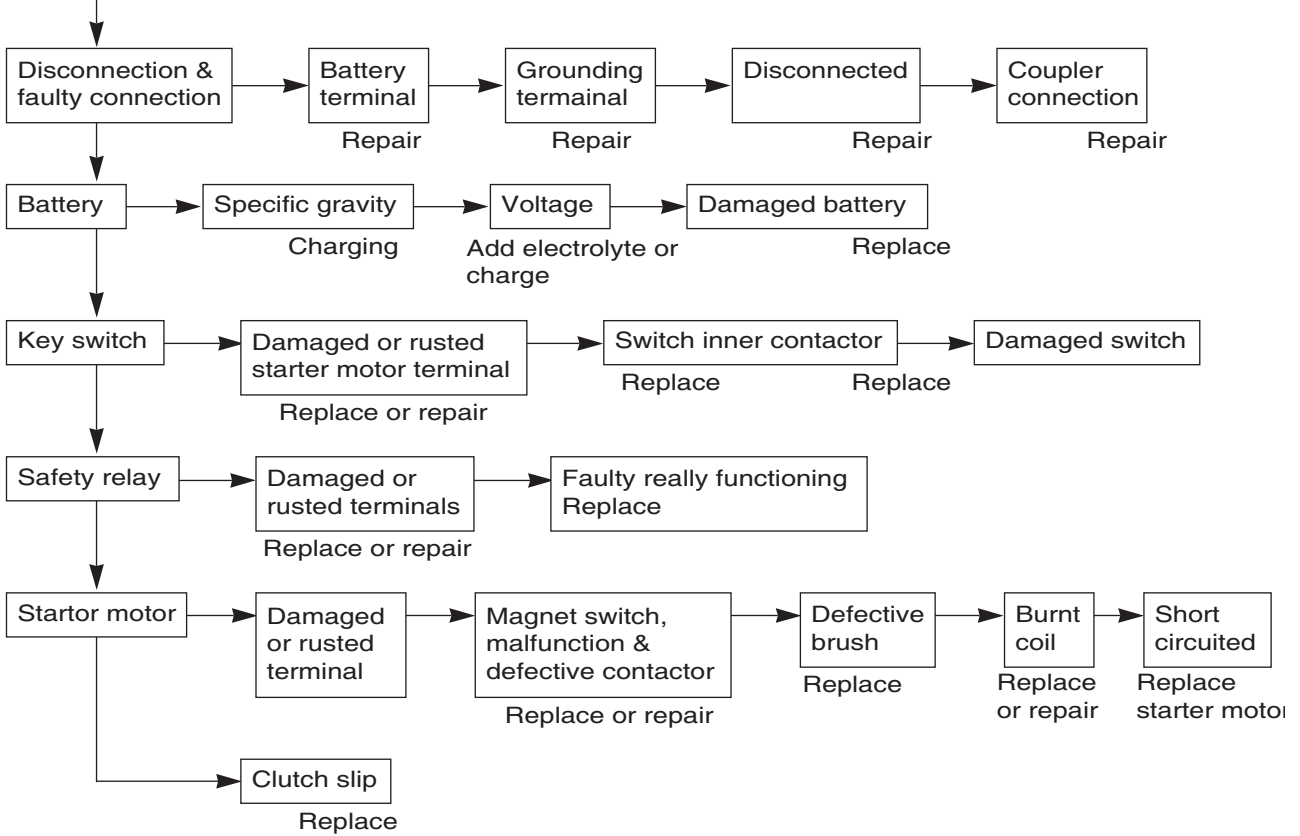

Hydraulic pressure source

**Hydraulic system will not operate or to slow function**

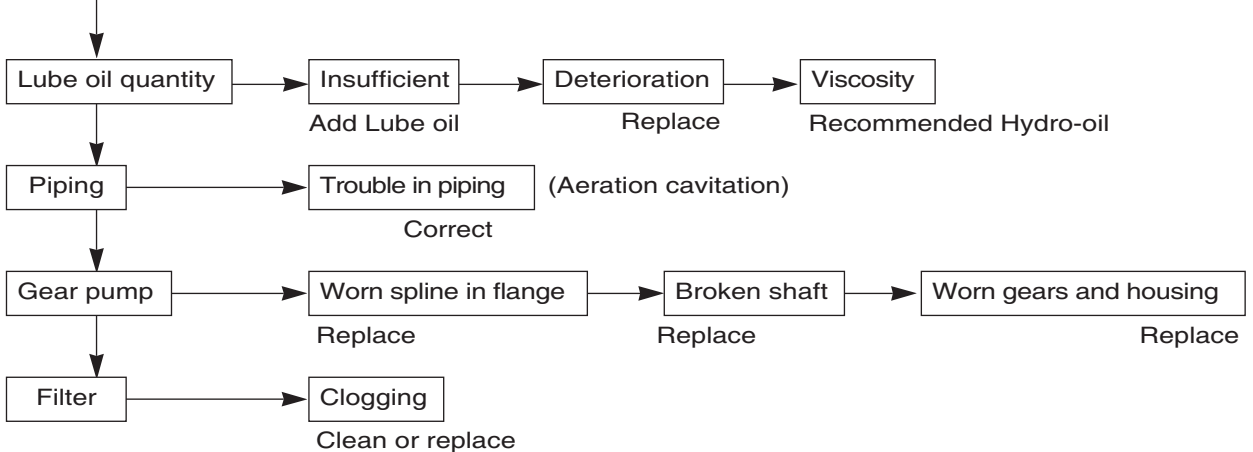

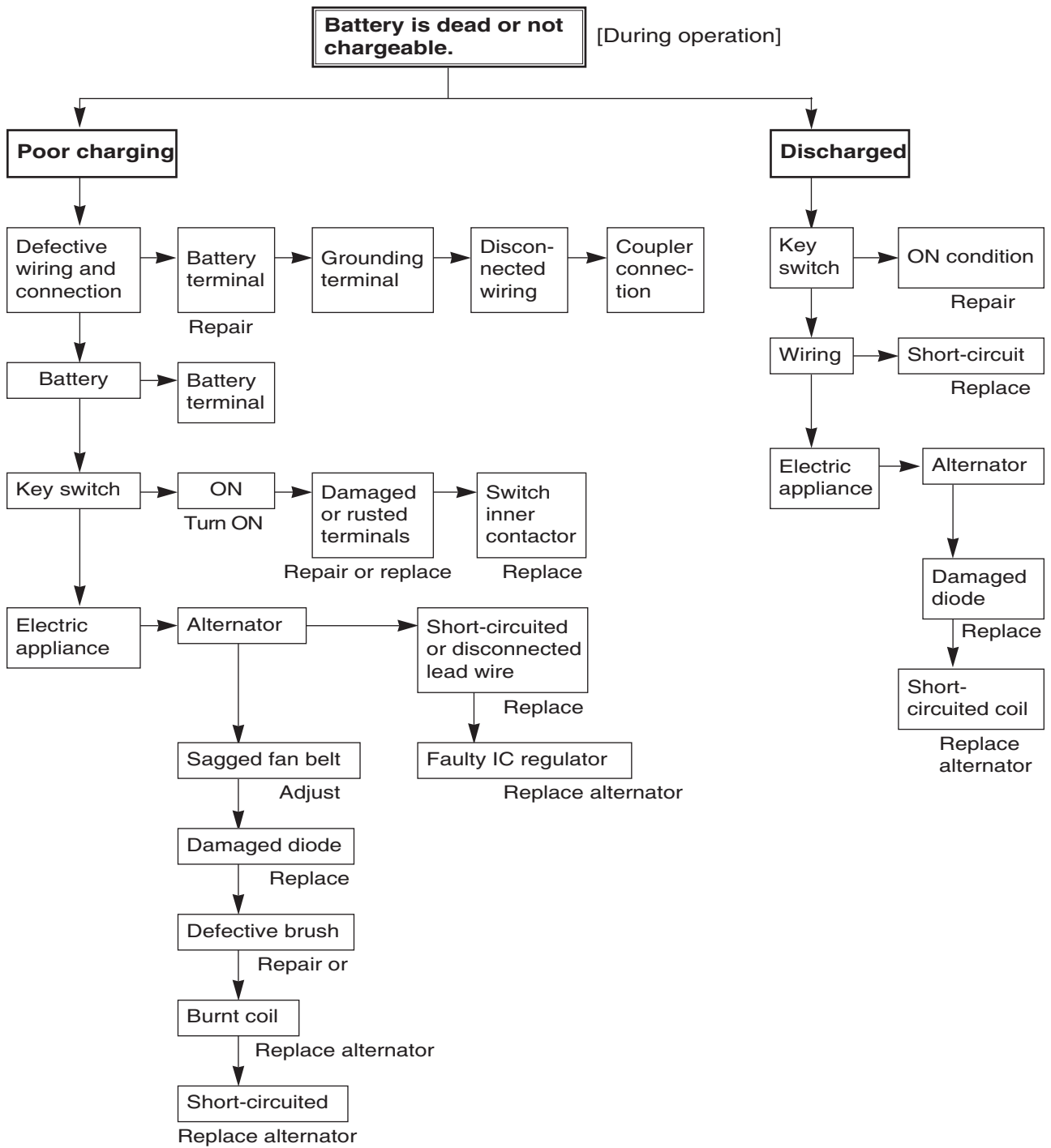

## 9. Tightening Torque

- Tightening torque for major parts

Major Parts	Screw (diameter x pitch)	Strength (grade)	Tightening Torque	Remarks
Cylinder head bolt	M14 x 1.5	10.9T	1st: 6.0 kg·m 2nd: 90° 3rd: 90° 4th: 90° Finished: 60° (Angle Method)	COLLARD DUO BOLT
Connecting rod bearing cap bolt	M14 x 1.5	12.9T	1st Step 4 ±0.2 kg·m 2nd Step 60° ±3°	
Crankshaft main bearing cap bolt	M16 x 1.5	12.9T	30.0 kg·m	
Balance weight fixing bolt	M12 x 1.5	10.9T	10.0 kg·m	
Flywheel fixing bolt	M14 x 1.5	10.9T	18 ±3.6 kg·m	
Crankshaft gear fixing bolt	M12 x 1.5	10.9T	13.0 kg·m	

- Tightening torque for injection pump system

Parts	Tightening Torque
Injection pump delivery valve holder	11.0 ~ 12.0 kg·m
Nozzle holder fixing cap nut to cylinder head	7.0 kg·m
Nozzle fixing cap nut of nozzle holder	6.0 ~ 8.0 kg·m
High pressure injection pipe fixing cap nut	Max. 2.9 ~ 3.2 kg·m

- **Tightening torque table for standard bolt**

Refer to the following table for bolts other than described above.

Diameter x pitch (mm)	Degree of strength										
	3.6	4.6	4.8	5.6	5.8	6.6	6.8	6.9	8.8	10.9	12.9
	(4A)	(4D)	(4S)	(5D)	(5S)	(6D)	(6S)	(6G)	(8G)	(10K)	(12K)
	Limit value for elasticity (kg/mm <sup>2</sup> )										
	20	24	32	30	40	36	48	54	64	90	108
Tightening torque (kg·m)											
M5	0.15	0.16	0.25	0.22	0.31	0.28	0.43	0.48	0.50	0.75	0.90
M6	0.28	0.30	0.45	0.40	0.55	0.47	0.77	0.85	0.90	1.25	1.5
M7	0.43	0.46	0.70	0.63	0.83	0.78	1.20	1.30	1.40	1.95	2.35
M8	0.70	0.75	1.10	1.00	1.40	1.25	1.90	2.10	2.20	3.10	3.80
M8x1	0.73	0.80	1.20	1.10	1.50	1.34	2.10	2.30	2.40	3.35	4.10
M10	1.35	1.40	2.20	1.90	2.70	2.35	3.70	4.20	4.40	6.20	7.40
M10x1	1.50	1.60	2.50	2.10	3.10	2.80	4.30	4.90	5.00	7.00	8.40
M12	2.40	2.50	3.70	3.30	4.70	4.20	6.30	7.20	7.50	10.50	12.50
M12x1.5	2.55	2.70	4.00	3.50	5.00	4.60	6.80	7.70	8.00	11.20	13.40
M14	3.70	3.90	6.00	5.20	7.50	7.00	10.00	11.50	12.00	17.00	20.00
M14x1.5	4.10	4.30	6.60	5.70	8.30	7.50	11.10	12.50	13.00	18.50	22.00
M16	5.60	6.00	9.00	8.00	11.50	10.50	17.90	18.50	18.00	26.00	31.00
M6x1.5	6.20	6.50	9.70	8.60	12.50	11.30	17.00	19.50	20.00	28.00	33.00
M18	7.80	8.30	12.50	11.00	16.00	14.50	21.00	24.20	25.00	36.00	43.00
M18x1.5	9.10	9.50	14.50	12.50	18.50	16.70	24.50	27.50	28.00	41.00	49.00
M20	11.50	12.00	18.00	16.00	22.00	19.00	31.50	35.00	36.00	51.00	60.00
M20x1.5	12.80	13.50	20.50	18.00	25.00	22.50	35.00	39.50	41.00	58.00	68.00
M22	15.50	16.00	24.50	21.00	30.00	26.00	42.00	46.00	49.00	67.00	75.00
M22x1.5	17.00	18.50	28.00	24.00	34.00	29.00	47.00	52.00	56.00	75.00	85.00
M24	20.50	21.50	33.00	27.00	40.00	34.00	55.00	58.00	63.00	82.00	92.00
M24x1.5	23.00	25.00	37.00	31.00	45.00	38.00	61.00	67.00	74.00	93.00	103.00

Others:

1. The above torque rating have been determined to 70% or so of the limit value for bolt elasticity.
2. Tension is calculated by multiplying tensile strength by cross section of thread.
3. Special screws should be tightened to 85% or so of the standard value.

For example, a screw coated with MoS<sub>2</sub> should be tightened to 60% or so of the standard value.

## 10. Engine Assembly Tolerance

(unit: mm)

Item	Component	Inspection Item	Specifications	Limit for Use	Action	Remarks	
Engine body	Cylinder block and liner	Cylinder liner I.D. wear	Ø111 ~ Ø111.022	Ø111.222	Replace the liner	Measure the bottom of intact edge on the top	
		Liner projection	0.03 ~ 0.08	-		At top of cylinder block	
		Flatness of top of cylinder block	0.05	-	Correct it with surface grinder	For length 200 mm	
		Water pressure test (for 1 min.) (kg/cm <sup>2</sup> )	4	-	Replace in case of water leak		
	Cylinder head and valve	Valve seat press	Intake	0 ~ 0.3	0.55	Replace the valve seat	
			Exhaust	0 ~ 0.3	0.55		
		Cylinder head height	109.9 ~ 110.1	108.4	Replace the cylinder head		
	Water pressure test (for 1 min.) (kg/cm <sup>2</sup> )	4	-	Replace in case of oil leak	Water temperature: 70°C		
Major drive components	Piston	Maximum piston O.D.	Ø110.883 ~ Ø110.897	-	Replace the piston	Measure at the point 13 mm up from the bottom of the piston	
		Clearance between the piston and liner	0.041 ~ 0.221	0.3	Replace if worn over the limit		
		Piston ring groove width	Top ring	-	-	If the groove is over the limit, replace the piston	
			2nd ring	3.06 ~ 3.08	-		
			Oil ring	4.04 ~ 4.06	-		
		Piston projection at top of cylinder block	0.357 ~ 0.533	-		Measure the bottom of intact edge on the top	
	Allowable weight difference among pistons	±15 g	-	Replace the piston			
	Piston ring	Piston ring gap	Top ring	0.40 ~ 0.60	1.5	Replace the ring	Standard gauge I.D.: Ø108
			2nd ring	0.40 ~ 0.60	1.9		
			Oil ring	0.30 ~ 0.50	1.5		
		Piston ring side clearance	Top ring	-	-	Replace the ring or piston	The allowable limit is based on the standard clearance
			2nd ring	0.07 ~ 0.102	0.15		
			Oil ring	0.05 ~ 0.09	0.15		
	Direction of ring opening	-	-	Install rings only with their openings 120° apart			
	Piston pin	Piston pin O.D.	Ø41.994 ~ Ø42	Ø41.94	Replace the piston pin		
Clearance between piston pin and piston groove		0.003 ~ 0.015	0.08	Replace if wear amount is over the specification			

(unit: mm)

Item	Component	Inspection Item	Specifications	Limit for Use	Action	Remarks
Major drive components	Crankshaft	Uneven wear on journal and pin	-	0.01	Repair it with a grinder	Lateral/longitudinal
		Journal O.D.	Ø83.966 ~ Ø83.988	Ø83	Use the undersize bearing (0.25, 0.5, 0.75, 1.0)	
		Pin O.D.	Ø70.971 ~ Ø70.990	Ø70		
		Ovalness of journal and pin	0.008	0.025		
		Allowable concentricity of journal and pin	0.01	0.03		
		Allowable inclination of journal and pin	0.02	0.03		
		Clearance between crankshaft and main bearing	0.052 ~ 0.122	0.25	Replace the bearing	Measure at the crown section
		Axial play of crankshaft	0.1 ~ 0.289	0.5	Replace the thrust bearing	
		Crankshaft deflection	0.06↓	0.1	Repair it with a press	Bearing No. 4 (Supporting No. 1 and 7)
		Crankshaft levelness (g·cm)	60↓	60 or below	Check the dynamic balancing	Measure at 400 rpm
		Journal bearing cap bolt tightening torque (kg·m)	30	-	Apply oil to the bolt	There should be no foreign material on the bearing cap mounting surface
		Journal bearing crush	0.08 ~ 0.110	-		Tighten the bearing cap and unscrew one bolt for measurement
		Oil seal wear (Back side of crankshaft)	-	-	Replace the oil seal if oil leak is found	
	Connecting rod	Connecting rod play	0.170 ~ 0.248	0.50	Replace the connecting rod	
		Clearance between connecting rod bearing and crank pin	0.034 ~ 0.098	0.25	Replace the bearing	
		Clearance between small end bushing and piston pin	0.050 ~ 0.081	0.12		
		Connecting rod bearing crush height	0.04 ~ 0.07	-		Tighten the bearing cap and unscrew one bolt for measurement
		Big end and small end side clearance	-	0.50	Replace the connecting rod	
		Allowable weight difference among connecting rods	30 g↓	-		
		Connecting rod bearing cap bolt tightening torque (kg·m)	1st: 4 kg·m ±0.2 2nd: 60° ±3°	-	Remove oil from bolt	Remove foreign materials from the connection surface

(unit: mm)

Item	Component	Inspection Item	Specifications	Limit for Use	Action	Remarks
Major drive components	Camshaft	Camshaft journal O.D.	Ø57.86 ~ Ø57.88	Ø57.52		
		Clearance between camshaft and bushing	0.12 ~ 0.17	0.24	Replace the cam bushing	
		Axial play of camshaft	0.28 ~ 0.43	0.6	Replace the thrust plate	
		Camshaft deflection	0.05	0.2	Repair or replace the camshaft	
	Timing gear	Clearance between idle shaft bushing and idle shaft	0.025 ~ 0.091	0.15		
		Axial play of idle gear	0.043 ~ 0.167	0.3	Repair or replace the gear	
Gear backlash (cam, idle, crank and injection pump)		0.16 ~ 0.28	0.35	Replace the gear		

(unit: mm)

Item	Component	Inspection Item	Specifications	Limit for Use	Action	Remarks		
Exhaust valve	Valve	Intake valve stem O.D.	Ø8.950 ~ Ø8.970	Ø8.93	Replace the valve and valve guide	When replacing the valve, replace the guide as well		
		Exhaust valve stem O.D.	Ø8.935 ~ Ø8.955	Ø8.91				
		Clearance between valve stem and valve guide	Intake	0.030 ~ 0.065	0.1	Replace the valve and valve guide	Replace either one of them with more wear	
			Exhaust	0.045 ~ 0.080	0.15			
		Valve head thickness	Intake	2.7	2.2	Replace the valve		
			Exhaust	2.2	1.7			
		Clearance between valve guide and valve spring seat	Intake	2.0	-			
			Exhaust	2.0	-			
		Clearance between valve guide and cylinder head mounting hole		-0.039 ~ -0.010	-		Press fit after applying oil to the valve guide	
		Concentricity of valve seat and guide		0.05	-		Excluding spring seat	
		Intake valve spring	Free length	Approx. 64	-	Replace the valve spring		
			Tension (kg) (Measuring length: 41 mm)	67 ~ 73	66.5			
			Squareness (free)	1.5°	-			
		Exhaust valve spring	Inner	free length	73.8	-	Replace the valve spring	
				Tension (kg) (Measuring length: 38 mm)	36 ~ 40	-		
			Squareness (free)	1.5°	-			
		Outer	free length	77.7	-	Replace the valve spring		
			Tension (kg) (Measuring length: 41 mm)	71 ~ 79	-			
			Squareness (free)	1.5°	-			
		Contact surface of valve stem and rocker arm		-	-		If the rocker arm or stem is excessively burred, repair or replace it	
Clearance between rocker arm shaft and rocker arm bushing		0.040 ~ 0.113	0.2	Replace the bushing or shaft				
Rocker arm shaft wear		Ø23.939 ~ Ø23.96	Ø23.75	Replace				
Push rod deflection		-	0.3	Replace				

(unit: mm)

Item	Component	Inspection Item	Specifications	Limit for Use	Action	Remarks	
Valves	Tappet	Clearance between tappet and cylinder block	0.035 ~ 0.077	0.15	Replace the tappet		
		Tappet O.D.	Ø19.944 ~ Ø19.965	-	Replace the tappet		
		Contact of tappet and cam	-	-	Replace if excessive wear or deformation is found		
Lubrication system	Oil pressure	Oil pressure (kg/cm <sup>2</sup> ) (at rated speed)	4.8 or below	3.5	Check for oil leakage and clearance at each section		
		Oil pressure (kg/cm <sup>2</sup> ) (idling without load)	0.8 ~ 1.4	0.6	Use the recommended oil		
	Oil temperature	Max. allowable oil temp. (Main gallery) (°C)	-	105		No temperature higher than this are allowed	
		Instant allowable oil temp. (Main gallery) (°C)	-	120			
	Oil pump	Axial clearance of oil pump gear		0.055 ~ 0.105	-	Replace the gear or cover	
		Clearance between gear shaft and oil pump cover hole		0.032 ~ 0.077	-		
		Clearance between drive gear shaft and cover hole		0.040 ~ 0.094	-	Replace the bushing or cover	
		Gear shaft O.D.		Ø16.950 ~ Ø16.968	-	Replace the gear shaft	Ø17e7
		Drive gear bushing O.D.		Ø28.000 ~ Ø28.033	-	Replace the bushing	Ø28e7
		Backlash	Crank gear and idle gear	0.15 ~ 0.25	0.8	Adjust the backlash	
	Pump drive gear and idle gear		0.15 ~ 0.25	0.8			
	Valve opening pressure	Oil pressure adjusting valve (kg/cm <sup>2</sup> )		4.0 ~ 5.0	-	Replace the valve	
		Bypass valve for oil filter element (kg/cm <sup>2</sup> )		1.8 ~ 2.3	-		
		By-pass valve for oil cooler (kg/cm <sup>2</sup> )		5.0 ~ 6.0	-		
Relief valve for oil pump (kg/cm <sup>2</sup> )		8.5 ~ 11.5	-				
Adjusting valve for injection nozzle (kg/cm <sup>2</sup> )		1.5 ~ 1.8	-				
Oil filter	Damaged oil filter cartridge		-	-	Clean or replace		

(unit: mm)

Item	Component	Inspection Item	Specifications	Limit for Use	Action	Remarks
Cooling system	Radiator	Corrosion, damage or poor contact of radiator or pump	-	-	Repair or replace	
		Air leak test (air pressure) (kg/cm <sup>2</sup> )	1.0	-	Place the part into water. Replace it if air bubbles are seen	
		Pressure valve's opening pressure (kg/cm <sup>2</sup> )	0.5	-		
		Negative pressure valve's opening pressure (kg/cm <sup>2</sup> )	20	-		
	Coolant pump	displacement (l/min) - Engine speed: 1,800 rpm - Coolant temperature: 80°C - Negative pressure: 0.5kg/cm <sup>2</sup> )	190 or higher	-	Check the coolant passage	Clogged
		Clearance between pump impeller and housing body	0.35	-	Replace if the impeller and housing touch each other	
		Squareness of pulley	0.3	-	Repair it with a bench press	
	Coolant temperature	Operating temperature (suitable temperature) (°C)	94 ~ 98	95		No temperature higher than this are allowed
		Instant allowable temp. (°C)	105	105		
	Thermostat	Thermostat's opening temperature (under atmospheric pressure)(°C)	79	-	Replace	Type 2) Opening temperature: 83°C Fully open temperature: 95°C
Thermostat's fully open temperature (°C)		94	-	Replace if a defect is found. Lift: 8 mm or higher		
Fuel system	Pipe and others	Damaged, cracked poor packing of fuel pipe, injection pipe or nozzle holder	-	-	Repair or replace	
		Damaged fuel filter cartridge	-	-	Replace the cartridge	
	Injection pressure of injection nozzle (kg/cm <sup>2</sup> )		220	-	Adjust with shims	1st: 160 2nd: 220
	Injection pump's overflow valve opening pressure (kg/cm <sup>2</sup> )		1.0 ~ 1.5	-	Replace the valve	
	Protrusion height of cylinder head surface (mm)		3.6 ~ 4.1	-	Replace the cylinder head and nozzle	
Completion test	Engine test operation		-	-	Refer to the information for test operation in Appendix.	
	Cylinder compression pressure	Cylinder compression pressure (kg/cm <sup>2</sup> )	24 ~ 28	24 or higher	Repair	
		Compression pressure difference among cylinders	Below ±10% from average value	-	Repair	At 200 rpm or higher (20°C)

# Diesel Engine for Generators (Land/Marine) Digital Speed Controller User Manual

Ver\_1.07

300611-01127A(Land)

300611-01440(Marine)

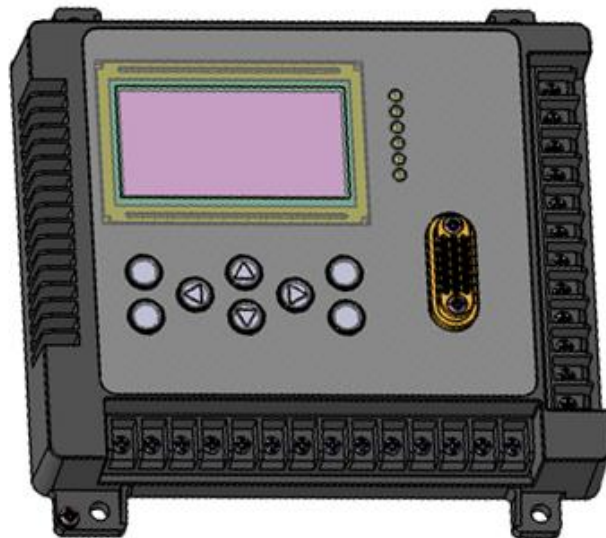

# HYUNDAI

HD Construction Equipment

# Contents

## 1. Product Overview and General Specification

1.1 Product Information	4
1.2 Product Appearance	4
1.3 Product Specification	5
1.4 Product System Diagram	6
1.5 Product I/O Signals	7
1.6 Product Dimension	8

## 2. Installation

2.1 Connecting to the Engine	9
2.1.1 Battery, Pick-up, Actuator Connection Diagram	9
2.1.2 Connecting to Batteries	10
2.1.3 Connecting to Actuators	10
2.1.4 Connecting to Pick-up Sensors	10
2.1.5 Operating Sequence for Digital Speed Controller	10
2.2 Connecting to Speed Trim, Droop, Idle and Other Inputs	11
2.2.1 Speed Trim, Droop, Idle and Other Inputs Diagram	11
2.2.2 Connecting to Speed Trim	12
2.2.3 Connecting to Droop	12
2.2.4 Connecting to Idle	12
2.2.5 Connecting to AUX	12
2.2.6 Connecting Power to External Devices	12
2.3 Connecting to Crank, Run, Over Speed and Communication	13
2.3.1 Crank, Run, Over Speed and Communication Connection Diagram	13
2.3.2 Connecting to Crank Terminals	13
2.3.3 Connecting to Run Terminals	14
2.3.4 Connecting to Over Speed Terminals	14
2.3.5 Connecting to CAN Communication	14
2.3.6 Connecting to RS232 Communication	14

## 3. Configuration and Operation

3.1 Input Keys	15
3.2 LCD Display Menu	16
3.2.1 LCD Displays After Powered On	17
3.2.2 LCD Main Menu Display	18
3.2.3 Engine Type Setup Menu	19

3.2.4 System Setup Menu	-----	19
3.2.5 PID Gain Setup Menu	-----	20
3.2.6 PID Auto Setup Menu	-----	21
3.2.7 DateTime Setup Menu	-----	21
3.2.8 Alarm List Menu	-----	21
3.2.9 Default Setup Menu	-----	22
3.2.10 System Info Menu	-----	22
3.3 Engine Configuration	-----	22
3.3.1 Engine Type Configuration	-----	22
3.3.2 System Setup Configuration	-----	24
3.3.3 PID Gain Setup Configuration	-----	29
3.3.4 PID Auto Setup Configuration	-----	30
3.3.5 DateTime Setup Configuration	-----	31
3.3.6 Alarm List	-----	31
3.3.7 Actuator Test	-----	32
3.3.8 Default Setup Functions	-----	32
3.3.9 System Info Functions	-----	33
3.3.10 LCD Setup Function Configuration	-----	33
3.3.11 System Monitor Function Configuration	-----	33

#### **4. How to Operate**

4.1 Operating Sequence for Digital Speed Controller	-----	34
4.2 Detailed Operating Sequence	-----	34

#### **5. Troubleshooting**

5.1 Alarm List Check	-----	35
5.2 System Checks and Measures	-----	36

#### **6. Warranty and A/S Service**

6.1 Warranty	-----	37
6.2 A/S Service Information	-----	37

# 1. Product Overview and General Specification

## 1.1 Product Information

**Digital Speed Controller (300611-01127A/01440)** is applicable to generator (vehicles and vessels) engines as a high performance embedded electronic control system designed based on PID control for fast and precise control of engine speed with an enhanced micro controller unit (MCU) that minimizes analog circuits vulnerable to user environments.

This product features PID auto setting functions along with battery voltage, pick-up sensors and actuator condition checking. It also has a black box function that manages engine operation records when faults are detected for users to have more convenience in operating this precise digital speed controller.

### [Product Features]

- Rigid and stable case structure and easily recognizable front design
- Readily understandable GUI (graphic user interface) with graphic LCD displays
- Easy and simple setup with 8 button keys without manual controls by users
- Fast setting available by migrating initial settings depending on types of the engines
- Listing fault messages (over speed, pick-up error, etc.) and recording messages
- RS232 and CAN ports available for communication
- Digital inputs and PID auto setup functions for PID control parameters
- Application of digital clock for fault timing and engine operating hours

## 1.2 Product Appearance

**Digital Speed Controller** is made of a rigid aluminum case taking into account anti-shock, electromagnetic resistance and environmental protection. An embedded system containing graphic LCD and high performance MCU is inside the controller and a heat sink is located on the outside of the case for protection and precise control of actuator operating elements.

A terminal block is located on the bottom and right of the front side for easy connection to external devices. Over speed, run and crank signals are displayed on the front LED and contact points (a or b) are also available for outputs on external controllers or indicators.

RS232 and CAN communication is available and DSUB-9 connector enables universal use of RS232 communication.

Users can easily input and adjust values for parameter inputs using 8 button keys. In addition, graphic LCD shows graphic displays, bar graphs and design symbols so that users can readily identify the control information while external LED displays important conditions of the engine.

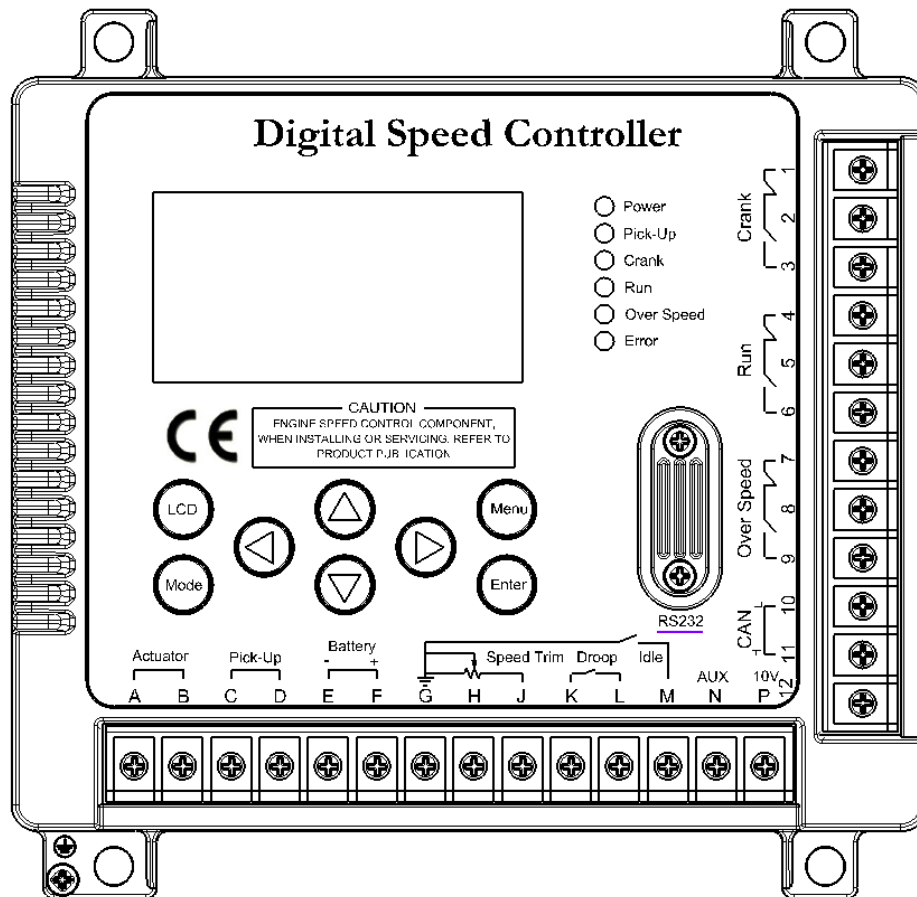

Figure 1: Product Front View

### 1.3 Product Specification

No.	Item	Description
1	MCU	16-bit DSC dsPIC33FJ256
2	Display	Graphic LCD 128*64
		LED: 6 EA
3	Keypad	8 Button Keys
4	Output	3 Contact Points (a and b)
5	Input	RMS 3V (Min)
6	Memory	128Mb
7	Communication	RS232 57600bps
		CAN (J1939) / 250kbps
8	Rated Power	DC 24V (12V to 32V)
9	Current Consumption	120mA
10	Operating Temperature	-20 to +70°C
11	Storing Temperature	-30 to +80°C
12	Operating Humidity	0 to 95%

## 1.4 Product System Diagram

### Cautions on wiring

- The total length of the Actuator(15AWG), Pick-up(24AWG\_Shield Cable), and Battery(15AWG) connections shall be limited to 10m or less.
- Refer to the system diagram (Figure 2) to wire the circuit and check the cable type.
- Wiring assembly must be checked before use as it will cause fatal damage to the controller.
- The fuse 10A for circuit protection is always provided at the front end of the battery input terminal "F".
- RS232 communication cable should use designated dedicated cable.
- It does not guarantee the fault of the product caused by not following the system diagram and wiring connection precautions.

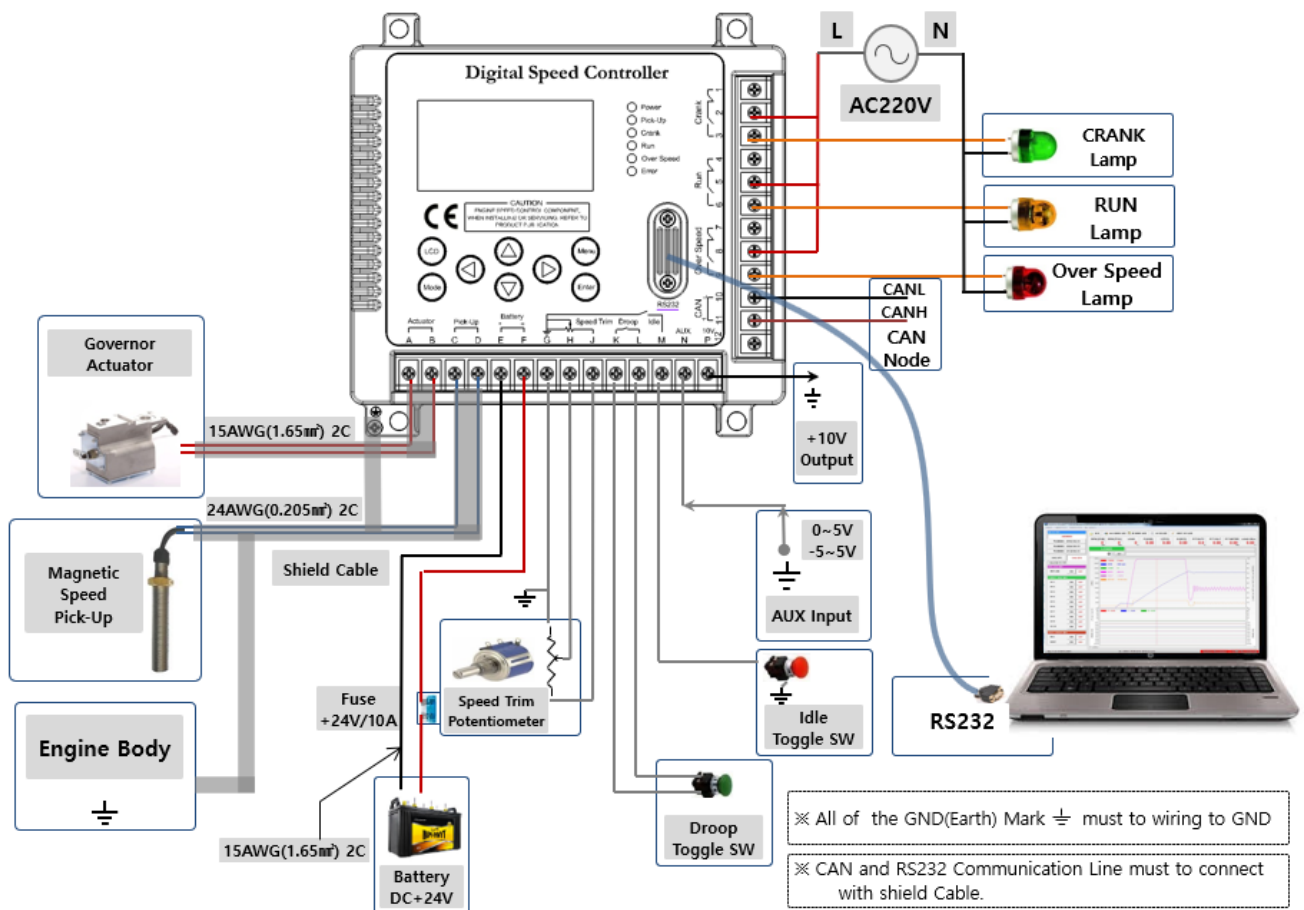

Figure 2: System Diagram for Digital Speed Controller

## 1.5 Product I/O Signals

No	Terminal	I/O type	Terminal Functions
1	Actuator ( A, B )	Output	Outputs are actuator control signals. Wiring should be 15AWG (105°C) or better. (However, terminals A and B can be used regardless of their polarities. Actuator's shield cable terminal should be connected to Ground(Engine body). (Voltage measuring terminals are A and E.)
2	Pick-Up ( C, D )	Input	Inputs are RPM sensor signals. Terminal D should be connected to the ground(Engine body) in connection with the shield cable. Gap between the RPM sensor and the gear tooth should be adjusted between 0.9 and 1.1mm (sensor inputs should be at least 3V AC RMS). Pick-up voltage shown on System monitor menu is Peak value
3	Battery Voltage (-E, +F)	Input	It is a power input terminal for the controller and inputs are DC +24V/10A. The positive pole of the battery should be connected to the terminal F. (Back voltage protection circuit is built in.)
4	Speed Trim (G, H, J)	Input (G)	It has a ground signal and is connected to the ground of the potentiometer.
5		Input (H)	Inputs are RPM trim signal values and the voltage level is between 0 and 5V. It is connected to the output of the potentiometer.
6		Input (J)	Outputs are DC +5V and it is connected to VCC of the potentiometer.
7	Droop ( K, L )	Input	Terminal K receives droop function selecting information. Terminal L has a ground signal and the switch is connected to terminals K and L. Once the terminal K is connected to the ground, droop starts to operate.
8	Idle ( M )	Input	Terminal M receives idle function selection signals. Once it is connected to the ground, idle operation starts.
9	AUX ( N )	Input	Terminal N receive load sharing and synchronization signal for parallel operation. The signal level is an input between DC -5 and +5V.
10	10V ( P )	Output	Outputs are +10V/20mA ratings and it can be used for various purposes including power to external auxiliary devices.
11	Crank Contact Point (1, 2, 3)	Output	The second crank contact point is a shared terminal while terminals 1 and 2 are for the contract point b and terminals 2 and 3 for the contact point a. The contact point a starts to operate when the digital speed controller reaches at the RPM delivering control signals to the actuator after the engine is activated.
12	Run Contact Point (4, 5, 6)	Output	The fifth run contact point is a shared terminal while terminals 4 and 5 are for the contact point b and terminals 5 and 6 for the contact point a. The contact point a starts to operate when the engine reaches its designated normal speed RPM.
13	Over Speed Contact Point (7, 8, 9)	Output	The eighth over speed contact point is a shared terminal while terminals 7 and 8 are for the contact point b and terminals 8 and 9 for the contact point a. The contact point a starts to operate when the engine reaches its designated over speed RPM.
14	CAN ( 10, 11 )	I/O	Terminal 10 is for CAN-L communication and 11 is for CAN-H communication. CAN-H and CAN-L are used for CAN communication.

15	Power LED	Output	When DC+24V power is supplied to the controller, the LED turns on in red on the power level.
16	Pick-Up LED	Output	When the controller receives normal input signals from the pick-up sensor, the LED turns on in green on the pick-up level.
17	Crank LED	Output	The 2- and 3-terminal contact point a starts to operate and the LED turns on in yellow on the crank level when the digital speed controller reaches at the RPM delivering control signals to the actuator after the engine is activated. When Cranking Rpm is exceeded, Crank LED turns off.
18	Run LED	Output	The LED turns on in green on the run level when the engine reaches its designated normal speed RPM with 5- and 6-terminal contact point a starting to operate.
19	Over Speed LED	Output	The LED turns on in red on the over speed level when the engine reaches its designated over speed RPM with 8- and 9-terminal contact point a starting to operate..
20	Error LED	Output	The LED turns on in red on the error level when abnormal events of the controller occur.
21	RS232	I/O	D-SUB 9PIN (male) is connected to the host through RS232 communication port. The specified dedicated line should be used and only terminals 2, 3, 5 shall be connected, and the other terminals shall not be connected.
22	Ground	Ground	GND part and earthing should be jointly connected before being earthed to generator's engine body.

## 1.6 Product Dimension

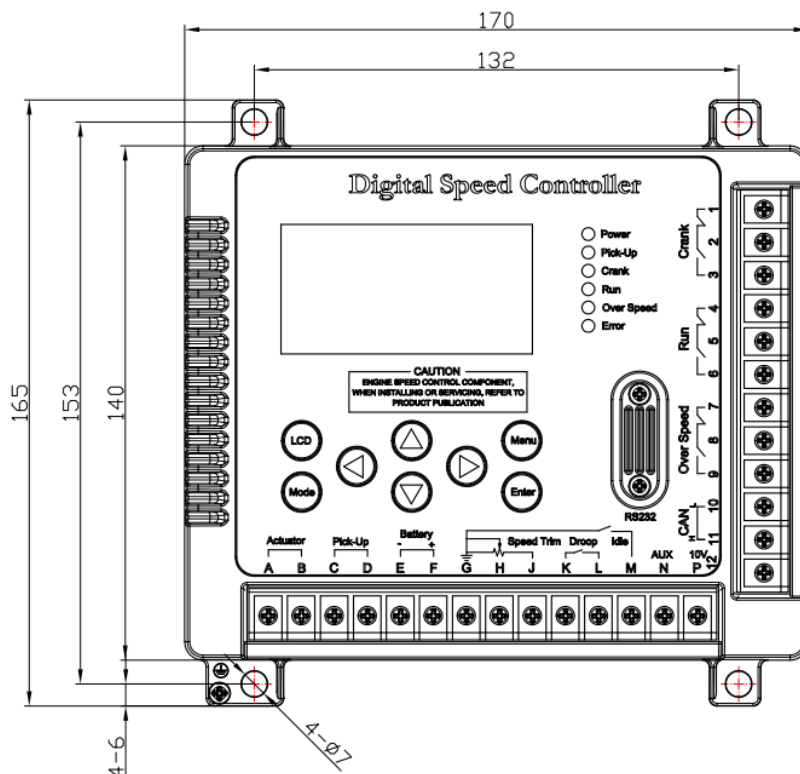

## 2. Installation

### Cautions for installing the digital speed controller

- Mount the controller unit vertically to the surface of a control cabinet to protect from water and high humidity, and do not expose the controller unit to the radiant heat.
- Do not rely solely on the electronic governor's actuator function to prevent overspeed, and use an independent fuel cut-off solenoid auxiliary device.
- When welding around the controller and charging the battery, the controller battery terminal is disconnected.
- We can not guarantee the failure of the product caused by installation neglect.

Digital Speed Controller should be connected to the pick-up sensor attached on the engine and the actuator. Speed trim, droop, idle and aux terminals can be used for additional functions in connection with surrounding circuits. Contact points a or b can also be used to operate external devices using crank, run and over speed functions. RS232 and CAN port allow communication with PCs or external host computers for data transfer and monitoring functions.

### 2.1 Connecting to the Engine

#### 2.1.1 Battery, Pick-Up and Actuator Connection Diagram

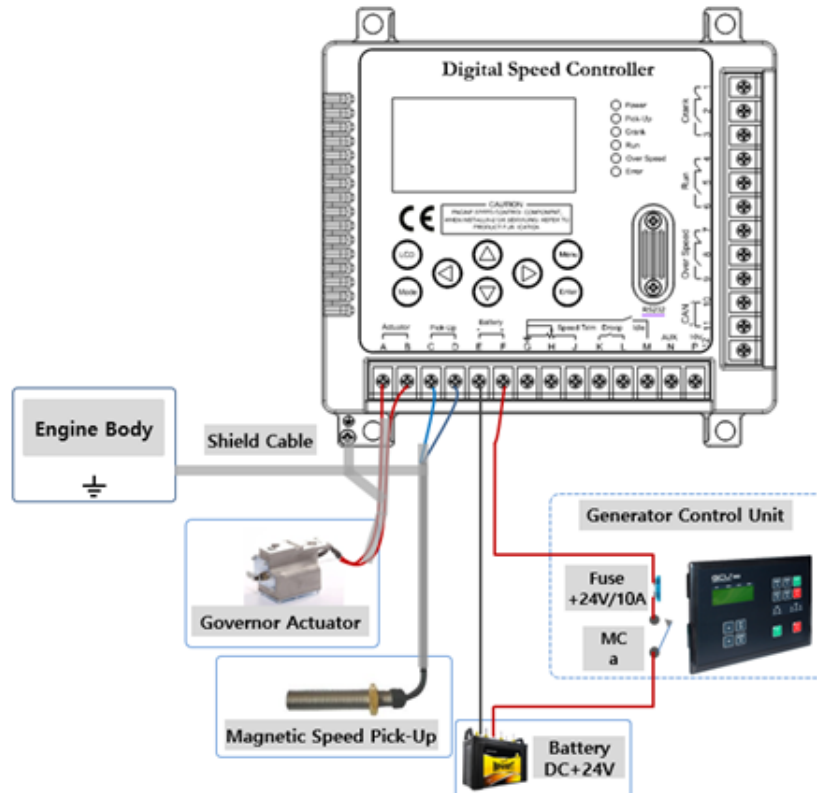

Figure 3: Battery, Pick-Up and Actuator Connection Diagram

### 2.1.2 Connecting to Batteries

Battery voltage is DC +24V and the battery is connected to the controller matching **E (-)** and **F (+)** with the respective polarities of the battery. **E (-)** is connected to **(-)** of the battery and **F (+)** to **(+)** of the battery. The circuit protection fuse 10A must be formed between the F (+) and the battery. Depending on cases, wiring can be done in a serial connection to the contact point a of MC and the fuse (DC +24V/10A) when connecting to system panels or generator control devices.

### 2.1.3 Connecting to Actuators

The actuator is also called governor and controls the amount of the fuel spray to the engine cylinder. The controller is connected to the actuator attached on the engine by connecting two wires of the controller terminal to A and B of the actuator regardless of their polarities. Use more than 15AWG(105°C) for the connection wire, and when using a shielded cable, the shield terminal should be connected to Ground(Engine body).

### 2.1.4 Connecting to Pick-Up Sensors

The pick-up sensor lets users know the engine speed and is connected to terminals **C** and **D** that can receive signals of AC RMS 3V or higher. Gap between the pick-up sensor and the gear tooth should be adjusted between 0.9 and 1.1mm. the shield terminal should be connected to Ground(Engine body).

### 2.1.5 Operating Sequence for Digital Speed Controller

- **Power On/Off:** It means that DC +24V power is either supplied or terminated through **E (-)** and **F (+)** of the battery matching with their respective polarities.
- **LCD On/Off:** It means to turn **on** or **off** the LCD display alone while DC +24V power is supplied through **E (-)** and **F (+)** of the battery matching with their respective polarities and the controller is in operation.

#### [Operating Sequence for the Controller]

- Step1)** When DC +24V power is supplied to the controller, the controller starts to operate. It indicates that power LED turns on and the power is being normally supplied.
- Step2)** Inputs for speed trim, droop and idle functions are received.
- Step3)** The controller checks the signals of the speed pick-up sensor.
- Step4)** Actuator control signals are output together with designated values of other information for crank, run and over speed functions according to the PID control values.
- Step5)** The controller checks the operation condition and displays LED outputs and fault messages according to the detected information.

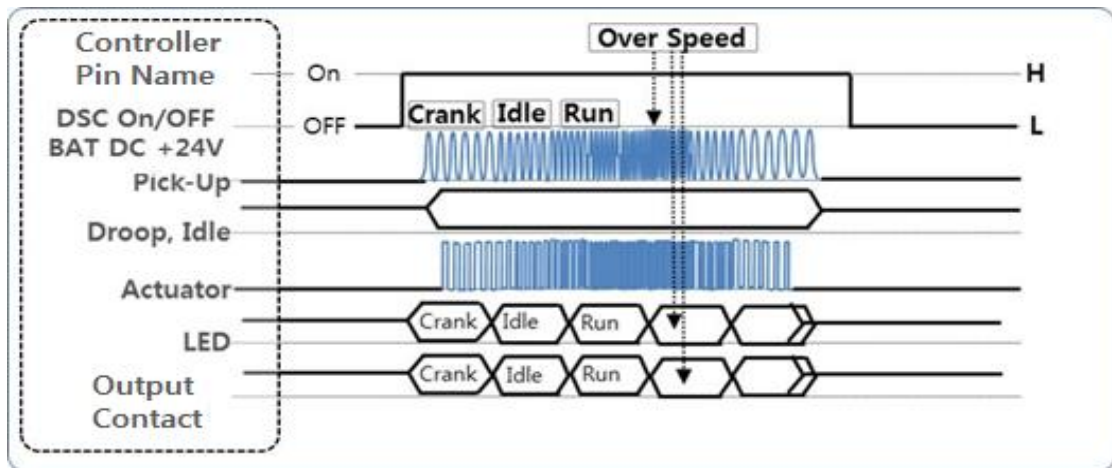

Figure 4: Time Chart for Operation of the Controller

## 2.2 Connecting to Speed Trim, Droop, Idle and Other Inputs

### 2.2.1 Speed Trim, Droop, Idle and Other Inputs Diagram

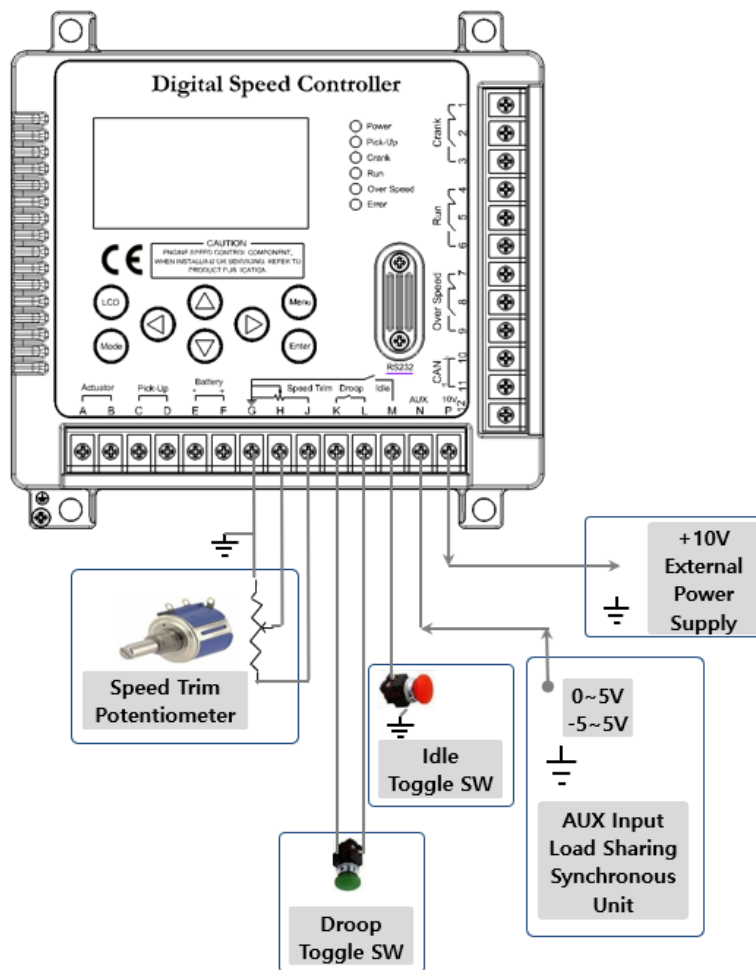

Figure 5: Speed Trim, Droop, Idle and Other Inputs Diagram

### 2.2.2 Connecting to Speed Trim

Speed trim is an analog voltage signal port for input to fine-tune the engine speed. A potentiometer is used for precise adjustment of the resistance values. The potentiometer needs to be connected to terminals **G**, **H** and **J**. Terminal **G** should be connected to the ground and it is recommended to use shielded cables. Terminal H is the terminal to which the fine adjustment voltage value (0 ~ 5V) is input. Terminal J is a terminal that is connected to VCC of the potentiometer with DC + 5V output.

### 2.2.3 Connecting to Droop

The switch is connected to terminals **K** and **L**. Signals indicating whether **droop** function works or not serve as inputs to the controller by keeping K and L either **open** or **close**. Inputs can be done by toggle or converting switches.

### 2.2.4 Connecting to Idle

The port on one side of the switch is connected to terminal **M** and the port on the other side to the **ground**. Connection between terminal **M** and the **ground** becomes either **open** or **close** by keeping the switch **open** or **close**. When connection between the terminal and the **ground** becomes **close**, the controller will have **idle** function. Inputs can be done by toggle or converting switches.

### 2.2.5 Connecting to AUX

AUX is a terminal for control signal inputs from load sharing devices or synchronization devices through terminal **N**. It shares load from the generator in parallel operation and receives signal inputs from synchronization devices for the controller to control changes to load. Input signal level is between **DC -5** and **5V** and it is recommended to use shielded cables for signal wires.

### 2.2.6 Connecting Power to External Devices

It can supply power output of **10V/20mA** to external devices through terminal **P**. Users can easily use this terminal when external auxiliary devices need power supply.

However, power supply of **20mA** or higher should not be used and care should be given to prevent short circuits.

## 2.3 Connecting to Crank, Run, Over Speed and Communication

### 2.3.1 Crank, Run, Over Speed and Communication Connection Diagram

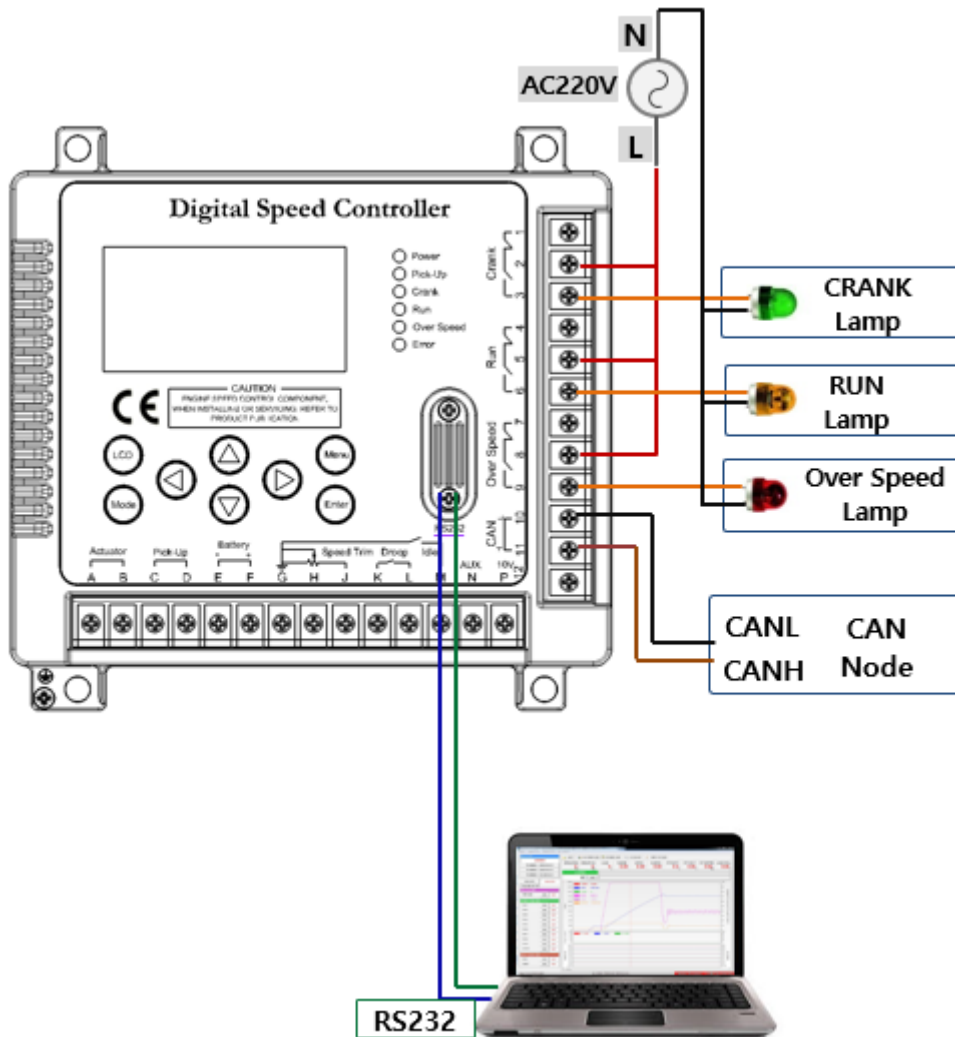

**Figure 6: Crank, Run, Over Speed and Communication Connection Diagram**

It is used to deliver operation information to external devices by activating contact point (a or b) when activating crank, run or over speed functions.

RS232 and CAN communication is connected to external PCs or hosts so that the controller can transmit system settings or operation information.

### 2.3.2 Connecting to Crank Terminals

Terminals **1**, **2** and **3** are the ones for **crank** output contact point and the contact point will be in operation when the controller activates the crank function. The second crank contact point is a shared terminal while terminals **1** and **2** are for the contact point **b** and terminals **2** and **3** for the contact point **a**.

Contact points **a** and **b** start to operate when the controller reaches at the RPM delivering control signals to the actuator after the engine is activated. The diagram shows wiring to operate AC220V lamp. The shared terminal is for 220V inputs and the **crank** lamp turns **on** when the contact point a starts to operate.

### 2.3.3 Connecting to Run Terminals

Terminals **4**, **5** and **6** are the ones for **run** output contact point and the contact point will be in operation when the controller activates the **run** function. The fifth crank contact point is a shared terminal while terminals **4** and **5** are for the contact point **b** and terminals **5** and **6** for the contact point **a**.

Contact points **a** and **b** start to operate when the engine reaches its designated normal speed RPM. The diagram shows wiring to operate AC220V lamp. The shared terminal is for 220V inputs the **run** lamp turns **on** when the contact point a starts to operate.

### 2.3.4 Connecting to Over Speed

Terminals **7**, **8** and **9** are the ones for **over speed** output contact point and the contact point will be in operation when the controller activates the **over speed** function. The eighth **over speed** contact point is a shared terminal while terminals **7** and **8** are for the contact point **b** and terminals **8** and **9** for the contact point **a**.

Contact points **a** and **b** start to operate when the engine reaches its designated over speed RPM. The diagram shows wiring to operate AC220V lamp. The shared terminal is for 220V inputs the **over speed** lamp turns **on** when the contact point a starts to operate.

### 2.3.5 Connecting to CAN Communication

Terminal **10** is for **CAN-L** communication and terminal **11** for **CAN-H** communication. **CAN-H** and **CAN-L** are used for CAN communication with remote control and monitoring of the controller operation. The communication code is based on **J1939**.

### 2.3.6 Connecting to RS232 Communication

D-SUB 9pin (female) is for RS232 communication for connection to external PCs or hosts. The specified dedicated line should be used and only terminals 2, 3, 5 shall be connected, and the other terminals shall not be connected. It can configure system parameters of the controller or communicate with analytic applications.









### 3. Configuration and Operation

The controller can be configured and operated by input keys according to the menus on the LCD display by selecting proper ones and assigning values in the selected menu to input control information to the system. Input information should immediately apply to the controller system once updated.

#### 3.1 Input Keys

The controller has 8 input keys including LCD, Mode, Menu, Enter, Up, Down, Left and Right.

Each key as respective functions as follows:

-  **LCD** LCD key turns on and off the display.
-  **Mode** Mode key switches the display to either operation mode or wave form display.
-  **Menu** Menu key lets users change the menu display and go back to the previous menu.
-  **Enter** Enter key applies designated values on the LCD display to the system.
-  Up key lets users go up or increase values in the selected menu on the LCD display.
-  Down key lets users go down or decrease values in the selected menu on the display.
-  Left key lets users move to the left in the selected menu.
-  Right key lets users move to the right in the selected menu.

### 3.2 LCD Display Menu

The overall menu tree of the controller is as follows:

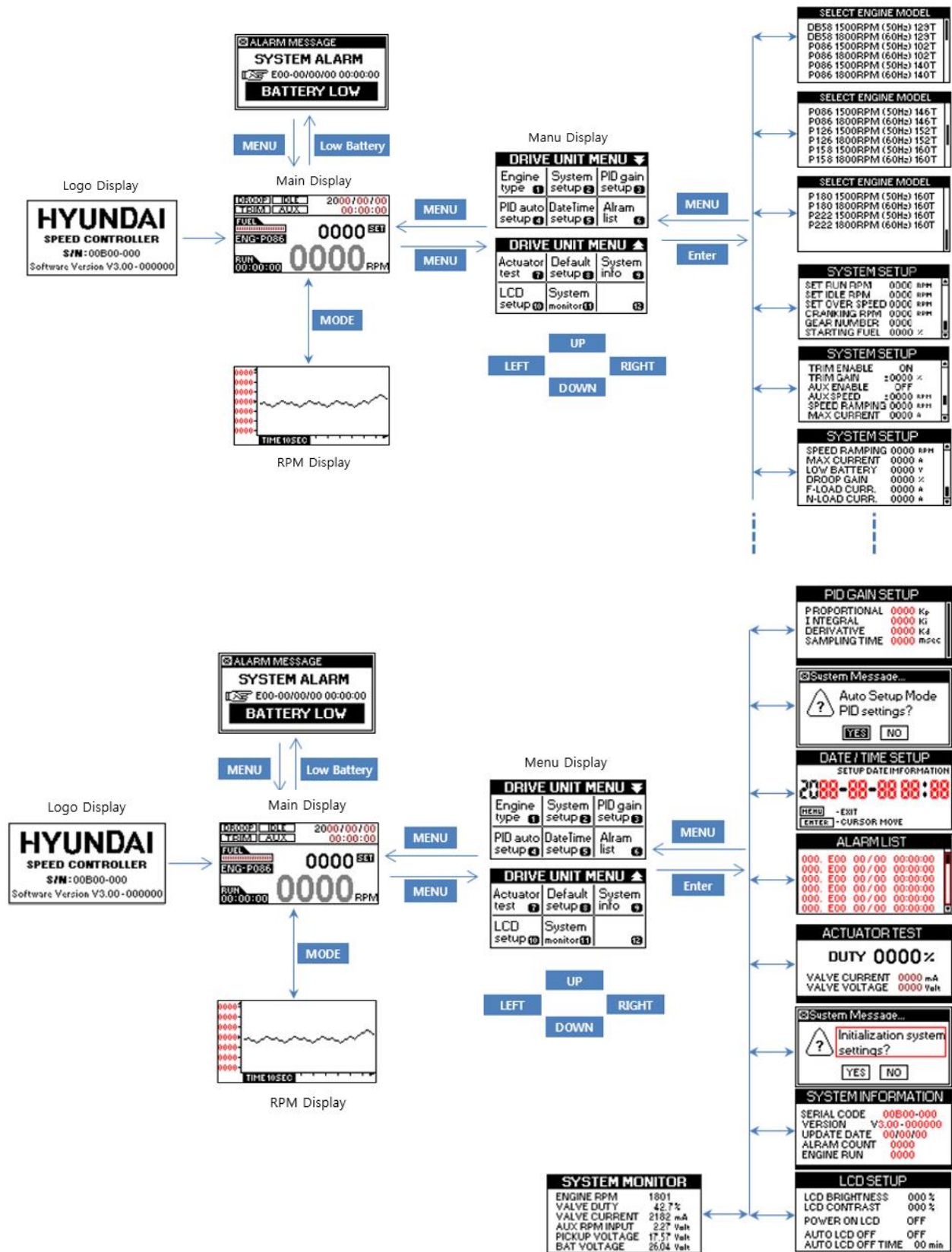

Figure 7: Overall LCD Menu Tree Diagram

### 3.2.1 LCD Displays After Powered On

When DC +24V power is supplied to the battery terminal (E (-), F (+)) of the controller, the **power** LED in the front side of the controller turns on in **red** and the **error** LED turns on in **red** where there are fault conditions. At this moment, the LCD display is not activated and **HYUNDAI** logo will appear for 1 second followed by the operation display after pressing the **LCD** button.

The controller will start control based on information from pick-up sensor and other input devices and designated parameter values. At this moment, where breakdowns of the surrounding devices or system errors occur, the LCD display will show such errors and processing messages.

**Step 1) DC +24V power supply to the terminals E (-) and F (+)**

When DC +24V power is supplied to the terminals E (-) and F (+), the controller will start to operate with the LCD display off. After pressing the **LCD** button, **HYUNDAI** logo will appear for 1 second as shown below followed by the controller operation display. Then, the LCD display will switch between on and off by pressing the **LCD** button.



Figure 8: **HYUNDAI** Logo

**Step 2) The operation display will show 1 second after the logo appears.**

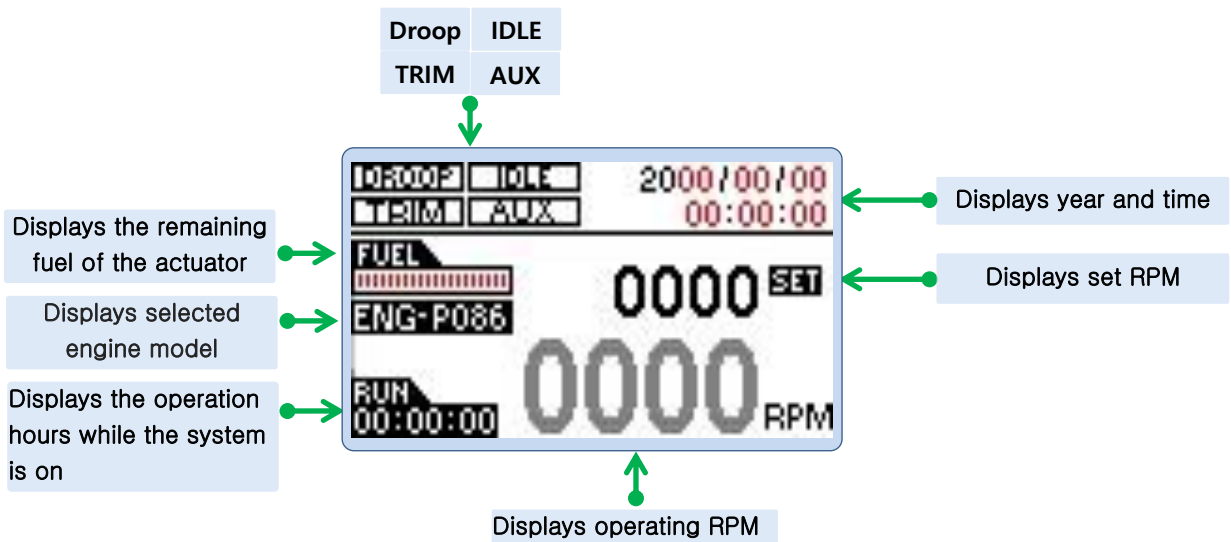
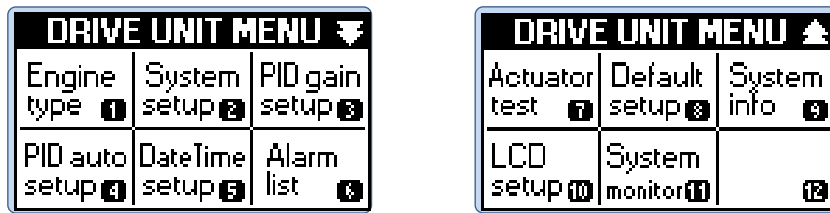

Figure 9: Operation Display

### 3.2.2 LCD Main Menu Display

#### Displays main menu screen of the controller

The main menu of the controller has 10 sub-menus.



Menu 1: Main Menu of the Controller - 1 to 2

#### 1) Engine type

The controller can start operation once the initial system values are configured. Users can load preset values depending on types of the engines by selecting the type.

#### 2) System setup

It consists of sub-menus related to system settings including RUN/IDLE/OVERSPPEED/CRANK/GEARNUMBER.

#### 3) PID gain setup

It consists of sub-menus to designate Kp, Ki and Kd parameter values related to the engine PID control.

#### 4) PID auto setup

It offers function for automatic designation of Kp, Ki and Kd parameter values related to the engine PID control.

#### 5) DateTime setup

It offers function for users to move to the screen for designating year, month, day and hour.

#### 6) Alarm list

It offers function for users to move to the alarm display for the alarm list.

#### 7) Actuator Test

It offers menu to test the impedance ( $X_L$ ) of the actuator and any problems in operating load current. It displays current and voltage according to the duty values.

#### 8) Default setup

It offers menu to apply designated default values to the selected engine.

#### 9) System info

It offers menu that shows information of the controller. Such information includes the serial number, software version, last update date, alarm count and engine runs.

#### 10) LCD setup

It offers menu to configure LCD operating conditions including brightness, auto on/off and off hours.

#### 11) System monitor

It offers menu to monitor the controller operation. It shows values for Engine RPM, Valve Duty, Valve Current, Aux RPM Input, Pickup Voltage and Bat Voltage.

### 3.2.3 Engine Type Setup Menu

This menu offers function to configure setting values of the controller depending on types of the engines in advance and apply such preset values to the selected engine.

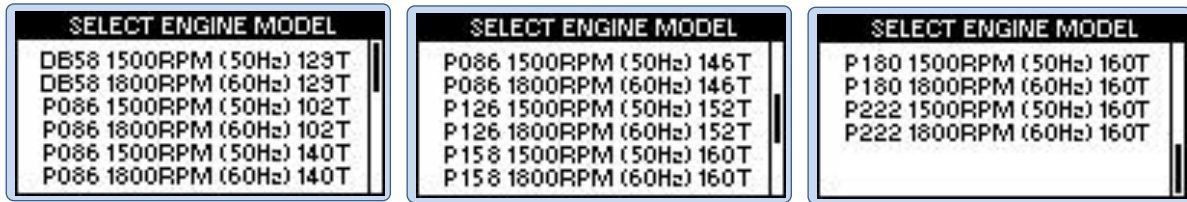

Menu 2: Engine Type Selection Menu

### 3.2.4 System Setup Menu

#### System Setup Menu Display of the Controller

It consists of sub-menus for the system configuration items of the controller including the one for configuring RUN/IDLE/OVERSPEED/CRANK/GEAR NUMBER related to RPM setting. Depending on additional functions, users can designate values for STARTING FUEL/SPEED RAMPING/ACTUATOR MAX/LOW BATTERY.

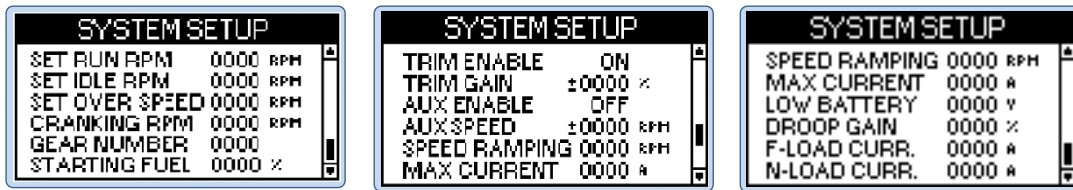

Menu 3: System Setup Menu - 1 to 3

#### 1) SET RUN RPM

Users can designate normal speed (target RPM) of the engine.

Users need to input different normal speed values depending on the specification of the selected engine.

#### 2) SET IDLE RPM

Users can designate the idle speed values of the engine as RPM.

Users need to input values to control the idle operating speed of the engine.

#### 3) SET OVER SPEED

Users can designate RPM values to activate engine protection function when the speed exceeds the normal level (target RPM) and reaches the overspeed range that may cause problems to the engine.

When the engine RPM reaches the over speed RPM range, the engine immediately stops with error messages and alarms.

#### 4) CRANKING RPM

Users can designate RPM values to activate the actuator when the engine starts to operate.

**5) GEAR NUMBER**

Users can input the number of flywheel teeth in the engine to the controller so that the controller can calculate the accurate RPM depending on the values of the pick-up sensor from the engine.

**6) STARTING FUEL**

Users can designate the amount of fuels used when the engine starts to operate and the operating current for the controller to activate the actuator changes based on these values.

**7) AUX SPEED**

Users can adjust values to ensure safe operation of the engine based on the AUX signal values when AUX is enabled.

**8) SPEED RAMPING**

Users can input ratio values of speed changes when the speed increases or decreases in the idle condition of the engine.

**9) MAX CURRENT**

Users can designate the maximum operating current for the **actuator** of the engine.

**10) LOW BATTERY**

It measures the battery voltage supplied to the controller. When the measured values are lower than the present voltage values, it will be alarmed. Usually, the acceptable battery voltage is between 20 and 22V (without load).

**11) DROOP GAIN**

Users can designate the droop values applicable to maximum load based on the current consumption of the **actuator**.

**12) F-LOAD CURR**

Users can designate the maximum current values when the generator is in full load.

**13) N-LOAD CURR**

Users can designate the operating current values of the actuator when the generator has no load.

**3.2.5 PID Gain Setup Menu**

Users can input Kp, Ki and Kd values as inputs to the PID control of the engine. Kp means proportional values while Ki means integral of the proportional values and Kd means differential of the proportional values.



**Menu 4: PID Gain Setup Menu**

### 3.2.6 PID Auto Setup Menu

The menu offers function for automatic designation of the P, I and D parameter values related to the engine PID control.

After starting the engine, select **DRIVE UNIT MENU** in the main menu while the engine has no load and then **PID auto setup** menu, press Enter. Then, the system message shows "Auto Setup Mode PID setting?" with YES or NO option. If you select YES, the controller will repeatedly change the RPM to automatically calculate the optimized P, I and D values.

If the controller identifies the optimized P, I and D values within 30 cycles, it will display "PID Auto Setup Complete, OK". When you press Enter, it will apply tuned P, I and D values and close the menu.

If the controller fails to identify the optimized P, I and D values within 30 cycles, it will display "PID No Successful, OK". When you press Enter, it will apply the final P, I and D values and close the menu.

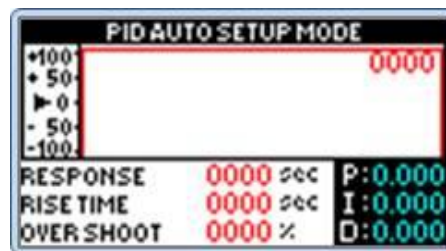

Menu 5: PID auto setup menu

### 3.2.7 Date/Time Setup Menu

Users can designate year, month, day, hour and minute for the controller and the designated time will be used to monitor the system and manage fault messages.

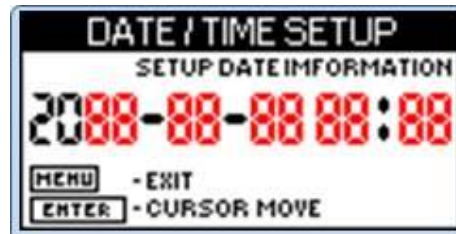

Menu 6: DATE/TIME SETUP Menu

### 3.2.8 Alarm List Menu

This menu displays year, month, day, hour and minute for the errors in the controller and types of the faults in codes which are used in troubleshooting.

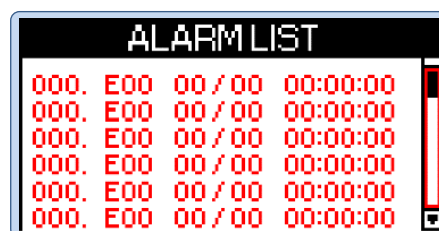

Menu 7: ALARM LIST Menu

### 3.2.9 Default Setup Menu

When you cannot identify the type of the control engine by the controller, this menu offers the most common parameter setting values. For default setup, select YES and then press Enter button. If you don't want to implement this function, press No button.

If you press YES, all the configuration values will be changed to the default ones of the engine.



Menu 8: Default Setup Menu

### 3.2.10 System Info Menu

The controller displays its information including the serial number, software version, last update date, alarm count and engine runs.

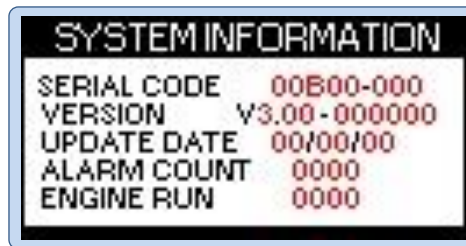

Menu 9: System Info Menu

## 3.3 Engine Configuration

### 3.3.1 Engine Type Configuration

Users can store control setting information depending on types of the engines in the internal memory of the controller. If you select your engine type, applicable parameters will be automatically configured accordingly. This feature is available for 21 different types of engines.

Designated Parameters by Engine Type (Land use)

No	Menu Name	Run RPM	Over Speed	Gear Teeth	Starting Fuel	PID Value
1	DB58 1500RPM (50Hz) 129T	1500RPM	1725RPM	129	65%	Optimized Value
2	DB58 1800RPM (60Hz) 129T	1800RPM	2070RPM	129	65%	Optimized Value
3	P086 1500RPM (50Hz) 102T	1500RPM	1725RPM	102	65%	Optimized Value
4	P086 1800RPM (60Hz) 102T	1800RPM	2070RPM	102	65%	Optimized Value
5	P086 1500RPM (50Hz) 140T	1500RPM	1725RPM	140	65%	Optimized Value
6	P086 1800RPM (60Hz) 140T	1800RPM	2070RPM	140	65%	Optimized Value
7	P086 1500RPM (50Hz) 146T	1500RPM	1725RPM	146	65%	Optimized Value
8	P086 1800RPM (60Hz) 146T	1800RPM	2070RPM	146	65%	Optimized Value

9	P126 1500RPM (50Hz) 152T	1500RPM	1725RPM	152	65%	Optimized Value
10	P126 1800RPM (60Hz) 152T	1800RPM	2070RPM	152	65%	Optimized Value
11	P126 1500RPM (50Hz) 106T	1500 RPM	1725RPM	106	65%	Optimized Value
12	P126 1800RPM (60Hz) 106T	1800 RPM	2070RPM	106	65%	Optimized Value
13	P158 1500RPM (50Hz) 160T	1500 RPM	1725RPM	160	65%	Optimized Value
14	P158 1800RPM (60Hz) 160T	1800 RPM	2070RPM	160	65%	Optimized Value
15	P158 2350RPM (60Hz) 160T	2350 RPM	2467RPM	160	65%	Optimized Value
16	P180 1500RPM (50Hz) 160T	1500 RPM	1725RPM	160	65%	Optimized Value
17	P180 1800RPM (60Hz) 160T	1800 RPM	2070RPM	160	65%	Optimized Value
18	P180 2350RPM (60Hz) 160T	2350 RPM	2467RPM	160	65%	Optimized Value
19	P222 1500RPM (50Hz) 160T	1500 RPM	1725RPM	160	65%	Optimized Value
20	P222 1800RPM (60Hz) 160T	1800 RPM	2070RPM	160	65%	Optimized Value
21	P222 2350RPM (60Hz) 160T	2350 RPM	2467RPM	160	65%	Optimized Value

### Designated Parameters by Engine Type (marine use)

No	Menu Name	Run RPM	Over Speed	Gear Teeth	Starting Fuel	PID Value
1	AD066TI 1500RPM (50Hz) 129T	1500 RPM	1725RPM	129	60%	Optimized Value
2	AD066TI 1800RPM (60Hz) 129T	1800 RPM	2070RPM	129	60%	Optimized Value
3	AD086TI 1500RPM (50Hz) 140T	1500 RPM	1725RPM	140	60%	Optimized Value
4	AD086TI 1800RPM (60Hz) 140T	1800 RPM	2070RPM	140	60%	Optimized Value
5	AD126TI 1500RPM (50Hz) 152T	1500 RPM	1725RPM	152	60%	Optimized Value
6	AD126TI 1800RPM (60Hz) 152T	1800 RPM	2070RPM	152	60%	Optimized Value
7	4AD126TIF 1500RPM (50Hz) 106T	1500 RPM	1725RPM	106	60%	Optimized Value
8	4AD126TIS 1800RPM (60Hz) 106T	1800 RPM	2070RPM	106	60%	Optimized Value
9	AD136 1500RPM (50Hz) 140T	1500 RPM	1725RPM	140	60%	Optimized Value
10	AD136 1800RPM (60Hz) 140T	1800 RPM	2070RPM	140	60%	Optimized Value
11	AD136T 1500RPM (50Hz) 140T	1500 RPM	1725RPM	140	60%	Optimized Value
12	AD136T 1800RPM (60Hz) 140T	1800 RPM	2070RPM	140	60%	Optimized Value
13	AD136TI 1500RPM (50Hz) 140T	1500 RPM	1725RPM	140	60%	Optimized Value
14	AD136TI 1800RPM (60Hz) 140T	1800 RPM	2070RPM	140	60%	Optimized Value
15	AD158TI 1500RPM (50Hz) 160T	1500 RPM	1725RPM	160	60%	Optimized Value
16	AD158TI 1800RPM (60Hz) 160T	1800 RPM	2070RPM	160	60%	Optimized Value
17	4AD158TI 1500RPM (50Hz) 160T	1500 RPM	1725RPM	160	60%	Optimized Value
18	4AD158TI 1800RPM (60Hz) 160T	1800 RPM	2070RPM	160	60%	Optimized Value
19	AD180TI 1500RPM (50Hz) 160T	1500 RPM	1725RPM	160	60%	Optimized Value
20	AD180TI 1800RPM (60Hz) 160T	1800 RPM	2070RPM	160	60%	Optimized Value
21	AD196TI 1500RPM (50Hz) 152T	1500 RPM	1725RPM	152	60%	Optimized Value
22	AD196TI 1800RPM (60Hz) 152T	1800 RPM	2070RPM	152	60%	Optimized Value
23	AD222TI 1500RPM (50Hz) 160T	1500 RPM	1725RPM	160	60%	Optimized Value
24	AD222TI 1800RPM (60Hz) 160T	1800 RPM	2070RPM	160	60%	Optimized Value
25	4AD222TI 1500RPM (50Hz) 160T	1500 RPM	1725RPM	160	60%	Optimized Value
26	4AD222TI 1800RPM (60Hz) 160T	1800 RPM	2070RPM	160	60%	Optimized Value

**Table 1: Configuration Values by Engine Type**

- **Engine Configuration Procedure**

**Step1)** Press **Menu** button of the controller and then you can see **DRIVE UNIT MENU**.

**Step2)** Select **Engine Type** by using **Up** and **Down** buttons in **DRIVE UNIT MENU** and then press **Enter** button.

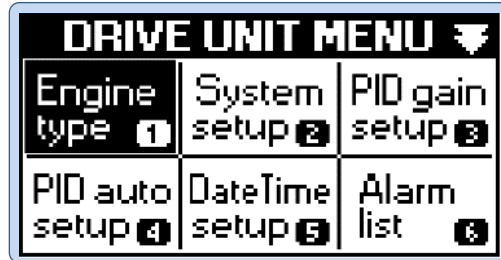

**Step3)** Go to **Engine Type** menu and select your engine type using **Up** and **Down** buttons. Then, press **Enter** button. At this moment, setting values according to the selected type of the engine are designated and will be used as information for the controller to control the actuator.

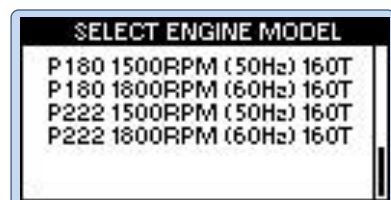
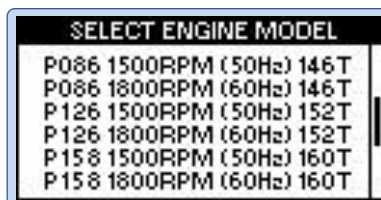
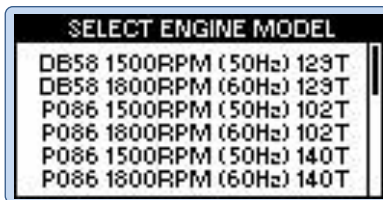

**Menu 10: Selection List by Engine Type**

### 3.3.2 System Setup Configuration

Main setting items of the controller includes **GEAR NUMBER**, **CRANKING RPM** and **SET RUN RPM**. You need to designate setting values to these items. Other system setup items are optional and therefore you can designate values for those items as necessary.

- **Configuring SET RUN RPM**

**Step1)** Press **Menu** button of the controller and then you can see **DRIVE UNIT MENU**.

**Step2)** Select **System setup** menu in **DRIVE UNIT MENU** using **Up**, **Down**, **Left** and **Right** buttons and then press **Enter** button.

**Step3)** Select **SET RUN RPM** in **SYSTEM SETUP** menu and then press **Enter** button. Use **Up** and **Down** buttons to increase or decrease the normal operating speed of the engine and then press **Enter** button.

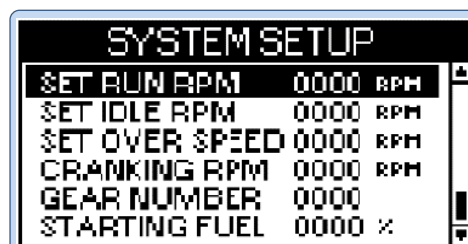
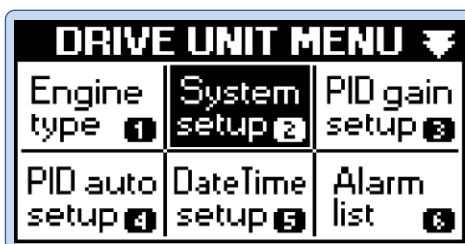

- **Configuring SET IDLE RPM**

**Step1)** Press **Menu** button of the controller and then you can see **DRIVE UNIT MENU**.

**Step2)** Select **System setup** menu in **DRIVE UNIT MENU** using **Up, Down, Left** and **Right** buttons and then press **Enter** button.

**Step3)** Select **SET IDLE RPM** in **SYSTEM SETUP** menu and then press **Enter** button. Use **Up** and **Down** buttons to increase or decrease the **idle** operating speed of the engine and then press **Enter** button.

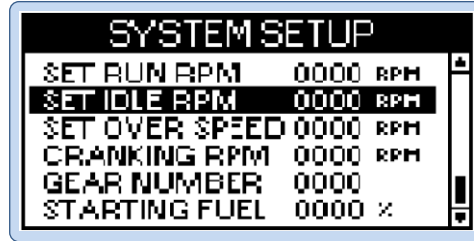
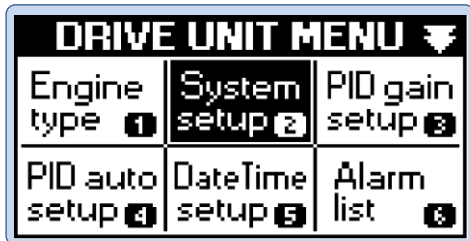

- **Configuring SET OVER SPEED**

**Step1)** Press **Menu** button of the controller and then you can see **DRIVE UNIT MENU**.

**Step2)** Select **System setup** menu in **DRIVE UNIT MENU** using **Up, Down, Left** and **Right** buttons and then press **Enter** button.

**Step3)** Select **SET OVER SPEED** in **SYSTEM SETUP** menu and then press **Enter** button. Use **Up** and **Down** buttons to increase or decrease the **over speed** values of the engine and then press **Enter** button.

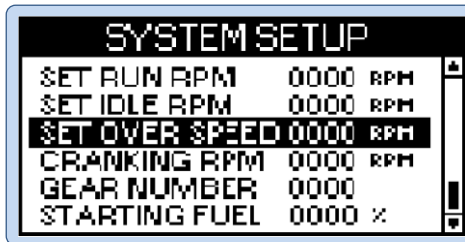
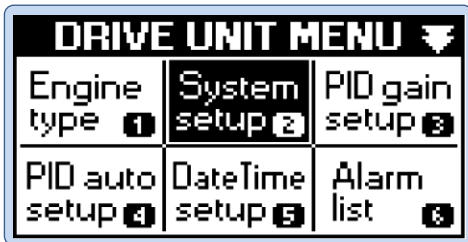

- **Configuring CRANKING RPM**

**Step1)** Press **Menu** button of the controller and then you can see **DRIVE UNIT MENU**.

**Step2)** Select **System setup** menu in **DRIVE UNIT MENU** using **Up, Down, Left** and **Right** buttons and then press **Enter** button.

**Step3)** Select **CRANKING RPM** in **SYSTEM SETUP** menu and then press **Enter** button. Use **Up** and **Down** buttons to increase or decrease the **RPM** values at which the controller starts to control the **actuator** when the engine starts to operate and then press **Enter** button.

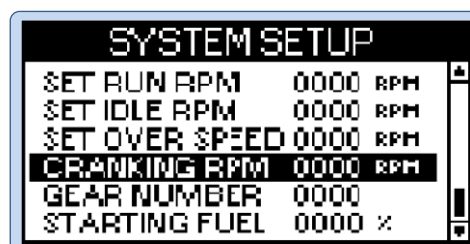
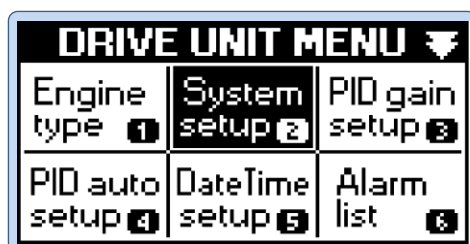

- Configuring **GEAR NUMBER**

**Step1)** Press **Menu** button of the controller and then you can see **DRIVE UNIT MENU**.

**Step2)** Select **System setup** menu in **DRIVE UNIT MENU** using **Up, Down, Left** and **Right** buttons and then press **Enter** button.

**Step3)** Select **GEAR NUMBER** in **SYSTEM SETUP** menu and then press **Enter** button. Use **Up** and **Down** buttons to increase or decrease the number of gear teeth in the engine and then press **Enter** button.

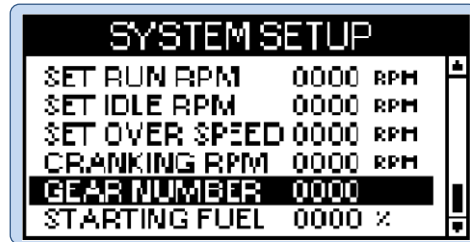
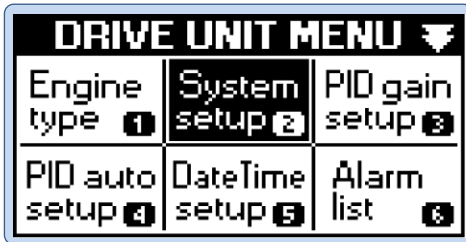

- Configuring **STARTING FUEL**

**Step1)** Press **Menu** button of the controller and then you can see **DRIVE UNIT MENU**.

**Step2)** Select **System setup** menu in **DRIVE UNIT MENU** using **Up, Down, Left** and **Right** buttons and then press **Enter** button.

**Step3)** Select **STARTING FUEL** in **SYSTEM SETUP** menu and then press **Enter** button. Use **Up** and **Down** buttons to increase or decrease the percentage for the amount of fuel sprayed when the engine starts and then press **Enter** button.

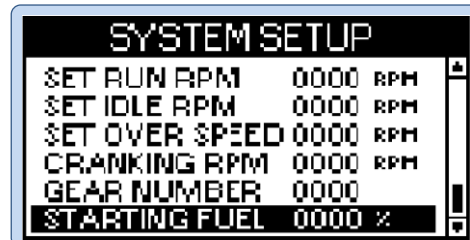
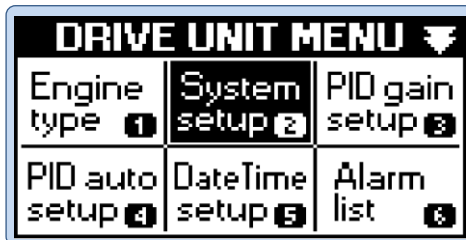

- Configuring **SPEED RAMPING**

**Step1)** Press **Menu** button of the controller and then you can see **DRIVE UNIT MENU**.

**Step2)** Select **System setup** menu in **DRIVE UNIT MENU** using **Up, Down, Left** and **Right** buttons and then press **Enter** button.

**Step3)** Select **SPEED RAMPING** in **SYSTEM SETUP** menu and then press **Enter** button. Use **Up** and **Down** buttons to increase or decrease the ratio of changes to the speed when increasing from the idle speed or decreasing from the increased speed and then press **Enter** button.

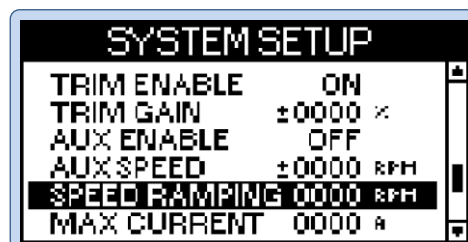
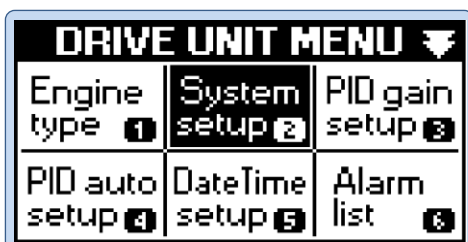

- Configuring **MAX CURRENT**

**Step1)** Press **Menu** button of the controller and then you can see **DRIVE UNIT MENU**.

**Step2)** Select **System setup** menu in **DRIVE UNIT MENU** using **Up, Down, Left** and **Right** buttons and then press **Enter** button.

**Step3)** Select **MAX CURRENT** in **SYSTEM SETUP** menu and then press **Enter** button. Use **Up** and **Down** buttons to increase or decrease the limit of the maximum current consumption of the **actuator** and then press **Enter** button (Max. 10A).

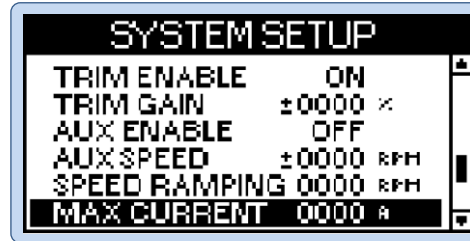
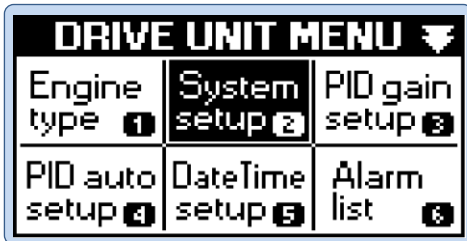

- Configuring **LOW BATTERY**

**Step1)** Press **Menu** button of the controller and then you can see **DRIVE UNIT MENU**.

**Step2)** Select **System setup** menu in **DRIVE UNIT MENU** using **Up, Down, Left** and **Right** buttons and then press **Enter** button.

**Step3)** Select **LOW BATTERY** in **SYSTEM SETUP** menu and then press **Enter** button. Use **Up** and **Down** buttons to input voltage values at which low battery alarms are activated and then press **Enter** button.

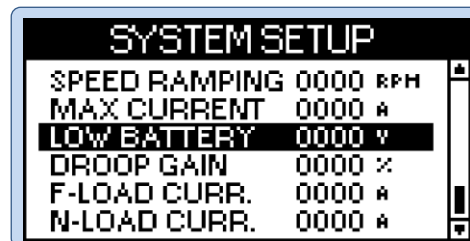
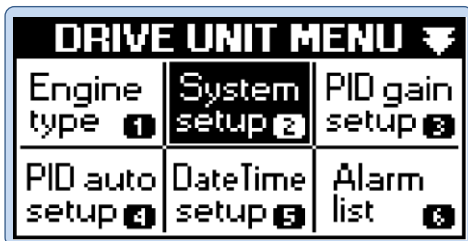

- Configuring **DROOP GAIN**

**Step1)** Press **Menu** button of the controller and then you can see **DRIVE UNIT MENU**.

**Step2)** Select **System setup** menu in **DRIVE UNIT MENU** using **Up, Down, Left** and **Right** buttons and then press **Enter** button.

**Step3)** Select **DROOP GAIN** in **SYSTEM SETUP** menu and then press **Enter** button. Use **Up** and **Down** buttons to increase or decrease the RPM values with adjusted ratio to decrease at the maximum load when the generator is in parallel operation and then press **Enter** button.

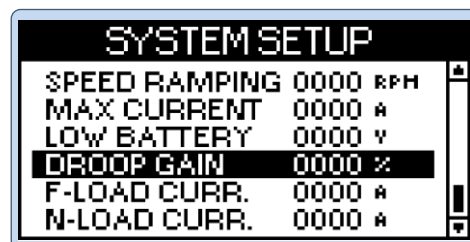
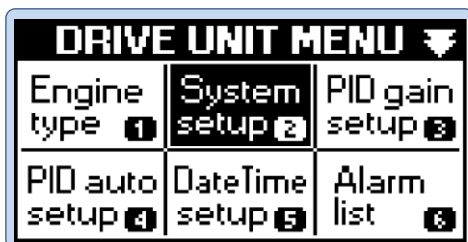

**DROOP Function**

Droop function is indicated in percentages as follows: RPM with no load is subtracted by RPM with maximum load and then divided by RPM with no load.

$$\text{Droop}\% = \frac{\text{RPM with no load} - \text{RPM with maximum load}}{\text{RPM with no load}}$$

**(Example for 3% Droop)**

Assuming that RPM with no load is 1,800 and RPM with maximum load is 1,854 then the percentage will be 3%. It means that the generator output will be changed by 33.3% as the frequency changes by 1% due to the actuator control.

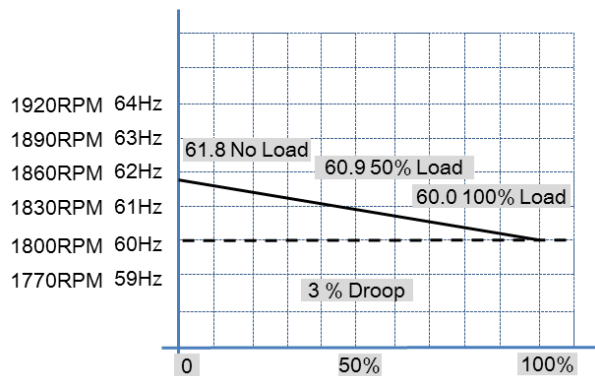

**Figure 10: 3% Droop**

**(Example for 7% Droop)**

Assuming that RPM with no load is 1,800 and RPM with maximum load is 1,926 then the percentage will be 7%. It means that the generator output will be changed by 14.3% as the frequency changes by 1% due to the actuator control.

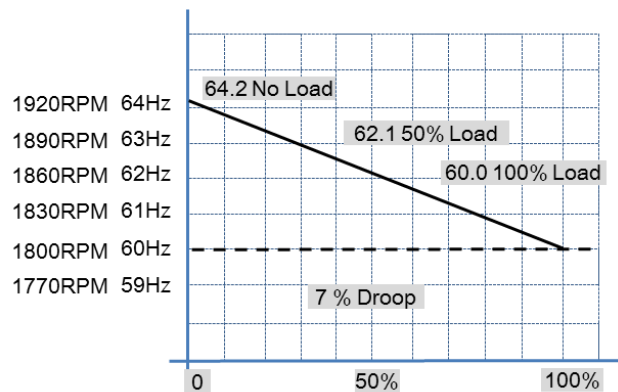

**Figure 11: 7% Droop**

- **F-LOAD CURR.**

**Step1)** Press **Menu** button of the controller and then you can see **DRIVE UNIT MENU**.

**Step2)** Select **System setup** menu in **DRIVE UNIT MENU** using **Up, Down, Left** and **Right** buttons and then press **Enter** button.

**Step3)** Select **F-LOAD CURR.** in **SYSTEM SETUP** menu and then press **Enter** button. Use **Up** and **Down** buttons to input the maximum current values of the **actuator** for the generator with full load and then press **Enter** button.

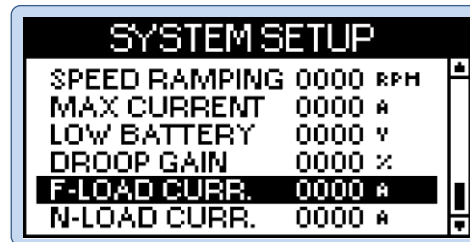
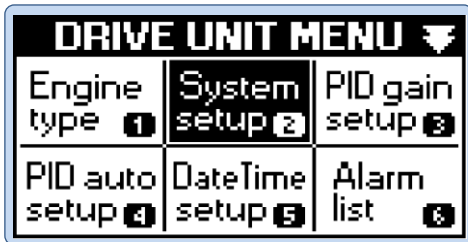

- **N-LOAD CURR.**

**Step1)** Press **Menu** button of the controller and then you can see **DRIVE UNIT MENU**.

**Step2)** Select **System setup** menu in **DRIVE UNIT MENU** using **Up, Down, Left** and **Right** buttons and then press **Enter** button.

**Step3)** Select **N-LOAD CURR.** in **SYSTEM SETUP** menu and then press **Enter** button. Use **Up** and **Down** buttons to input the operating current values of the **actuator** for the generator with no load and then press **Enter** button.

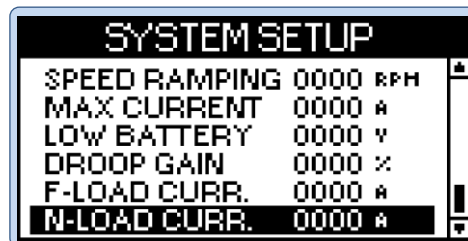
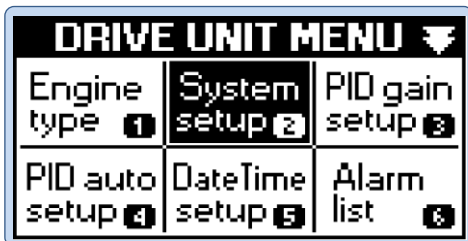

### 3.3.3 PID Gain Setup Configuration

- **Configuring PID Gain Kp, Ki and Kd Values**

**Step1)** Press **Menu** button of the controller and then you can see **DRIVE UNIT MENU**. Use **Up, Down, Left** and **Right** buttons to select **PID gain setup** menu and then press **Enter** button.

**Step2)** Use **Up** and **Down** buttons in **PID GAIN SETUP** to select **PROPORTIONAL, INTEGRAL** or **DERIVATIVE** and then press **Enter** button.

In **PID GAIN SETUP**, if a user sets the value over than 100 about each **P, I, D**, we could not the warrant of the product quality.

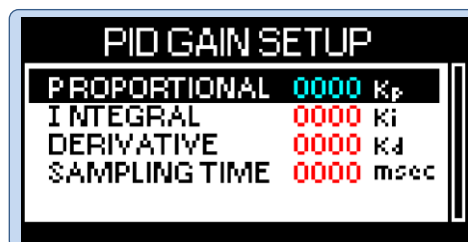
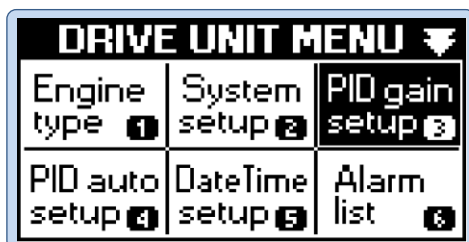

- Configuring **PID SAMPLING TIME**

**Step1)** Press **Menu** button of the controller and then you can see **DRIVE UNIT MENU**. Use **Up, Down, Left** and **Right** buttons to select **PID gain setup** menu and then press **Enter** button.

**Step2)** Use **Up** and **Down** buttons in **PID GAIN SETUP** to select **SAMPLING TIME** and then press **Enter** button. Use **Up** and **Down** buttons to input **SAMPLING TIME** values and then press **Enter** button.



### 3.3.4 PID Auto Setup Value Configuration

**Step1)** Select your type in Engine Type menu and then start the engine with the preset configuration values maintaining it with no load.

**Step2)** During the normal operation, press **Menu** button of the controller and then you can see **DRIVE UNIT MENU**. Use **Up, Down, Left** and **Right** buttons to select **PID auto setup** menu and then press **Enter** button.

**Step3)** The menu offers function for automatic designation of the P, I and D parameter values related to the engine PID control. Select PID auto setup menu in **DRIVE UNIT MENU** and then press Enter button to see the system message "Auto Setup Mode PID settings?" with YES or NO options.

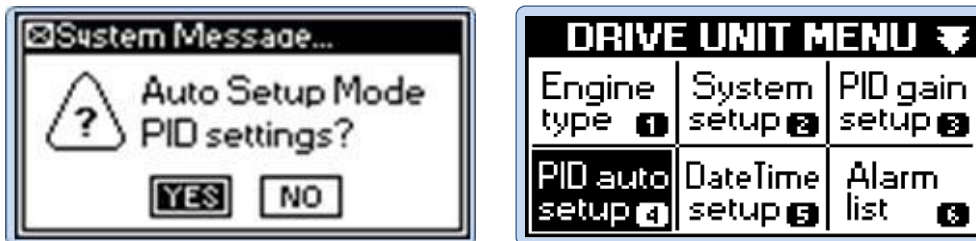

**Step4)** Press YES and then the system message "PID AUTO SETUP MODE" will appear. As PID auto setup was initiated during the operation, PID auto tuning is already in progress.

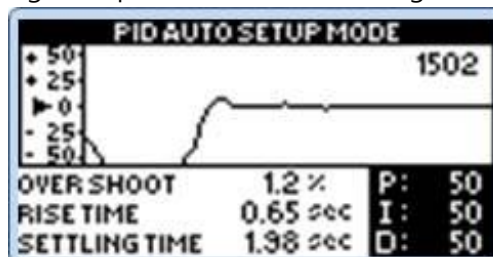

**Step5)** PID tuning repeats a process to obtain PID values and a window to indicate whether the process succeeded or failed will appear in several minutes (approx. 4 to 6 minutes). If the process succeeded, the system message window will appear together with OK button. If you press Enter button, you will go back to normal operation window and the auto-tuned values will apply to the normal operation that will be continued.

**Step6)** If auto-tuning failed to identify optimized P, I and D values within 4 to 6 minutes, the system message window will display failure. If you press Enter button, you will go back to normal operation window. If you want to repeat the process, you need to start with Step1 again.



### 3.3.5 DATE/TIME Value Configuration

**Step1)** press **Menu** button of the controller and then you can see **DRIVE UNIT MENU**. Use direction buttons to select **DateTime setup** menu.

**Step2)** Use **Up, Down, Left** and **Right** buttons to input year, month, day and hour and then press **Enter** button.



### 3.3.6 ALARM LIST

**Step1)** press **Menu** button of the controller and then you can see **DRIVE UNIT MENU**. Use direction buttons to select **Alarm List** menu and then press **Enter** button.

**Step2)** Use **Up, Down, Left** and **Right** buttons in **ALARM LIST** menu to confirm the fault messages.



[Alarm Code Table]

Alarm Code	Alarm Item	Description	Identified Alarm Output
E01	Battery Low	When the battery voltage continues to be lower than Low Battery voltage values for more than 5 seconds	LCD alarm message, Error LED lamp
E02	Battery High	When the battery maintains its voltage exceeding 30VDC for more than 5 seconds	LCD alarm message, Error LED lamp
E03	Pick-up Error	Problems in sensor signals when the engine starts. (Engine RPM lower than 600)	LCD alarm message, Error LED lamp
E04	Pick-up Error	Problems in sensor signals during the engine operation (Engine RPM 600 or higher)	LCD alarm message, Error LED lamp
E05	Actuator Current Short	Disconnection in the actuator or the connecting circuits	LCD alarm message, Error LED lamp
E06	Actuator Current Broken	Short-circuits in the actuator or the connecting circuits	LCD alarm message, Error LED lamp
E07	Over Speed	Engine RPM exceeding the configured over speed values	LCD alarm message, Error LED lamp
E08	FET Drive Error	Damages to components in the actuator output section inside the controller	LCD alarm message, Error LED lamp
E09	Pick-Up Lost	Pick-Up signal lost. (Engine RPM higher than 600rpm)	LCD alarm message, Error LED lamp

### 3.3.7 Actuator test

The menu offers function to test whether there is any problem in operating load current of the actuator attached to the engine. It indicates voltage and current for on/off.

### 3.3.8 Default setup Functions

**Step1)** Press **Menu** button of the controller and then you can see **DRIVE UNIT MENU**. Use **Up**, **Down**, **Left** and **Right** buttons to select **Default setup** menu and then press **Enter** button. At this moment, the system message **"Initialization system settings?"** will appear.

**Step2)** Use **Left** and **Right** buttons to select either **YES** or **NO** in **System Message** and then press **Enter** button.

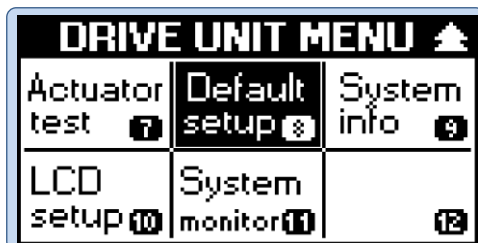

Default setup will change the configuration values of the engine to the default values. In order to initiate default setup, you need to select **YES** and then press **Enter** button. Press **No** button if you don't want to.

### 3.3.9 System info Functions

**Step1)** Press **Menu** button of the controller and then you can see **DRIVE UNIT MENU**. Use **Up**, **Down**, **Left** and **Right** buttons to select **System info** menu and then press **Enter** button.



The menu displays information of the controller and the information includes the serial number, software version, last update date, alarm count and engine runs.

### 3.3.10 LCD setup Functions

**Step1)** Press **Menu** button of the controller and then you can see **DRIVE UNIT MENU**. Use **Up**, **Down**, **Left** and **Right** buttons to select **LCD setup** menu and then press **Enter** button.

**Step2)** Use **Up** and **Down** buttons to select menus including **LCD BRIGHTNESS** and **LCD CONTRAST** for adjustment and then press **Enter** button. Use **Up** and **Down** buttons to input setting values and then press **Enter** button.

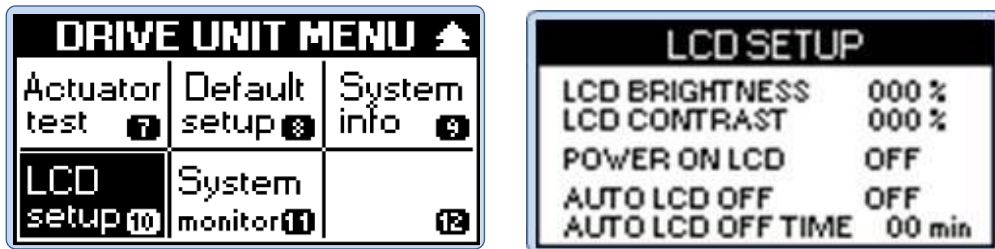

### 3.3.11 System monitor Functions

**Step1)** Press **Menu** button of the controller and then you can see **DRIVE UNIT MENU**. Use **Up**, **Down**, **Left** and **Right** buttons to select **System monitor** menu and then press **Enter** button. It offers menu to monitor the controller operation. It shows values for Engine RPM, Valve Duty, Valve Current, Aux RPM Input, Pickup Voltage(Peak Value) and Bat Voltage.

## 4. How to Operate

### 4.1 Operating Sequence for Digital Speed Controller

**STEP1) Supply DC +24V power to the battery terminals (E (-), F (+)) of the controller.**

**STEP2) Configure parameter values required for selection of the engine type and control of the engine.**

**STEP3) Install the controller on the generator system and complete circuit wiring.**

**STEP4) The controller will activate the actuator with power supply and pick-up sensor input.**

### 4.2 Detailed Operating Sequence

**STEP1) Supply DC +24V power to the battery terminals (E (-), F (+)) of the controller.**

Power supply to the controller can be done by direct connection to the battery or power supply controlled by external control devices. Fuses (15A/24V) are required for power supply to the controller through the terminal.

When the controller displays **Low Battery** Fault message, you need to charge the battery or replace it with the one having normal voltage before starting the controller.

**STEP2) Configure parameter values required for selection of the engine type and control of the engine.**

There are 3 ways to configure parameters required for the controller:

1. Using default setup
2. Designating the engine type in Engine Type menu
3. Configuring each parameter in System setup menu

For more information, see **Chapter 3**. Configuration and Operation.

**STEP3) Install the controller on the generator system and complete circuit wiring.**

Once the configuration is completed, the controller will be in **Stand By** condition preparing to receive input information from **pick-up** sensor and surrounding terminals and operate.

**STEP4) The controller will activate the actuator with power supply and pick-up sensor input.**

When the power is supplied and the **pick-up** terminal delivers normal sensor inputs as the **engine** starts, the **controller** activate the **actuator**.

## 5. Troubleshooting

### 5.1 Alarm List Check

Where there are problems in the system operation, you need to review the alarm list menu of the controller and then check the engine and the system in reference to the alarm codes.

Land/marine

Alarm Code	Alarm Item	Alarm Condition	Output Control	Measures
E01	Battery Low	When the battery voltage continues to be lower than Low Battery voltage values for more than 5 seconds	1. Alarm message pop-up on LCD 2. Error LED on	1. Check the battery line 2. Replace the battery
E02	Battery High	When the battery maintains its voltage exceeding 30VDC for more than 5 seconds	1. Alarm message pop-up on LCD 2. Error LED on	1. Check the battery line 2. Replace the battery
E03	Pick-up Error	Problems in sensor signals when the engine starts (Engine RPM lower than 600)	1. Alarm message pop-up on LCD 2. Error LED on 3. Actuator control signal off	1. Check the RPM sensor and connecting circuits 2. Replace the RPM sensor
E04	Pick-up Error	Problems in sensor signals during the engine operation (Engine RPM 600 or higher)	1. Alarm message pop-up on LCD 2. Error LED on 3. Actuator control signal off	1. Check the RPM sensor and connecting circuits 2. Replace the RPM sensor
E05	Actuator Current Short	Disconnection in the actuator or the connecting circuits	1. Alarm message pop-up on LCD 2. Error LED on	1. Check the disconnection in the actuator and connecting circuits 2. Replace the actuator
E06	Actuator Current Broken	Short-circuits in the actuator or the connecting circuits	1. Alarm message pop-up on LCD 2. Error LED on	1. Check the disconnection in the actuator and connecting circuits 2. Replace the actuator
E07	Over Speed	Engine RPM exceeding the configured over speed values	1. Alarm message pop-up on LCD 2. Error LED on 3. Actuator control signal off	1. Check the speed setting 2. Adjust PID setting values
E08	FET Drive Error	Damages to components in the actuator output section inside the controller	1. Alarm message pop-up on LCD 2. Error LED on 3. Actuator output power cutoff	1. Check the actuator and connecting circuits 2. Replace the controller
E09	Pick-Up Lost	Pick-Up signal lost. (Engine RPM higher than 600rpm)	1. Alarm message pop-up on LCD 2. Error LED on 3. Actuator output power cutoff	1. Check the RPM sensor and connecting circuits 2. Replace the RPM sensor

- 1) When problems described in alarm codes E03, E04, E07, E08 or E09 occur, the engine is not available for safe operation and therefore the engine will stop as the controller will turn off the actuator for safety.

- 2) When problems described in alarm codes E03, E04, E07 or E08 occur, the engine will not be able to restart as long as the alarm is not released.
- 3) When alarms occur, you can release them by turning off the power of the controller.

## 5.2 System Checks and Measures

For initial installation, it is recommended for you to check any disconnection in circuits before taking measures described here (see Chapter 2. Installation for how to install the controller).

**You can check the controller for failure diagnosis in accordance with the following procedure.**

**Step1)** Check the battery voltage whether it is higher than the Low Voltage setting value. If normal, supply power to the controller and then operate it. If the voltage is lower than the setting value, you need to charge the battery or replace it before operating the system.

**Step2)** Check the input resistance in the DC +24V input terminals (-E, +F) of the battery whether the resistance is higher than approx. 10K Ohm. If the resistance does not meet this condition, do not supply power to the controller and contact our A/S center for service request.

**Step3)** Check whether the power LED turns on or not after supplying power to DC +24V input terminals (-E, +F) of the battery. If the LED does not turn on, cut the power off and contact our A/S center for service request.

**Step4)** Check whether the power LED turns on and **HYUNDAI** logo appears on the LCD display after supplying power to DC +24V input terminals (-E, +F) of the battery. If you cannot see the logo, press LCD key button to check the LCD display once again. If you cannot still see the logo, cut the power off and contact our A/S center for service request.

**Step5)** Check the controller terminals (C & D) with AC meter or oscilloscope to check whether signal inputs of AC RMS 3V or higher are detected. If no signal detected, check whether the pick-up sensor maintains the gap between 0.9 and 1.1mm and then check whether the pick-up sensor has resistance of 110 Ohms ( $\pm 10\%$ ). If you cannot still detect no signal, replace the pick-up sensor and then operate the controller.

## **6. Warranty and A/S Service**

### **6.1 Warranty**

As this manual contains important contents related to safety, use and maintenance of the product. So please read this manual carefully and then use the product in a proper manner.

Those who are not familiar with the product should keep this manual close to it.

We are not responsible for human injuries or property damages caused by the following reasons:

- Where you use the product for purposes other than the ones described in this manual
- Where you alter the product or its components at discretion
- Where you disassemble the product at discretion to resolve problems
- Where you use accessories or parts not supplied or recommended by us
- ※ Where you use accessories or parts manufactured by other companies, please contact our service center to check their compatibility.

### **6.2 A/S Service Information**

- When you request A/S service, please let us know the model name, breakdown conditions and your contact information.
- Please ask the seller.



# Digital Panel for Marine Engines

## User Manual

Ver.1.2



# HYUNDAI

# ► Contents

1. General Information	
1.1 Product Information	3
1.2 Components and Optional Accessories	3
1.3 Product Specification	4
2. Product Installation	
2.1 Cautions	5
2.2 Desk Mounting Type	6
2.3 Flush Mounting Type	7
3. Part Names, Operation and Settings	
3.1 Front Side	8
3.2 Back Side	8
3.3 External Connection Terminals	9
3.3.1 Power Connector	9
3.3.2 Signal Connector	10
3.3.3 CAN Communication Connector	11
3.3.4 External Buzzer Connector	11
3.3.5 CCTV Connector	11
3.3.6 USB Connector	12
3.4 Fuse and Internal Buzzer	12
3.4.1 Fuse	12
3.4.2 Internal Buzzer	12
3.5 Key Switch	12
3.6 Start/Stop Button	13
3.7 Emergency Stop Button	13
3.8 Function Keys	14
3.8.1 Detailed Settings	15
3.9 Display Structure	16
3.9.1 Engine Speed (Tachometer)	16
3.9.2 Engine Water Temperature	17
3.9.3 Engine Oil Pressure	17
3.9.4 Exhaust Gas Temperature	17
3.9.5 Gearbox Oil Pressure	18
3.9.6 Battery Voltage	18
3.9.7 Sensor Check Lamp	18
3.9.8 Engine Alarm	19

# ► Contents

3.9.9	Engine Stop	-----	19
3.10	Spare Sensor	-----	20
3.11	Event Summary	-----	21
3.12	System Booting and Functional Check	-----	22
4.	Multi Panel Structure		
4.1	Multi Panels	-----	23
4.2	How to Install Multi Panels	-----	24
4.3	Multi Panel Settings	-----	25
5.	Maintenance		
5.1	Maintenance	-----	26
5.2	Troubleshooting	-----	26
6.	Warranty and A/S Service		
6.1	Warranty	-----	27
6.2	A/S Service Information	-----	27
7.	Appendix		
7.1	List of Engine Models	-----	28

# 1. General Information

## 1.1 Product Information

The name of the product model is a digital panel applicable to ships, generators and other various marine engines. The product is intended to improve problems of existing analog panels and allow users to check engine controls and conditions by means of a digital visualization product. It provides information in analog graphic gauges and digital displays for enhanced user experiences.

## 1.2 Components and Optional Accessories

### Components



① Digital Panel

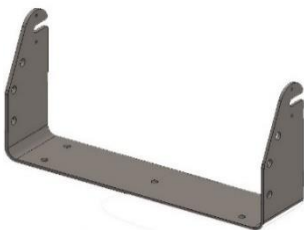

② Desk Mounting Type Bracket

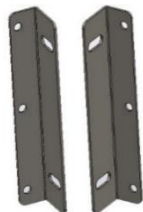

③ Flush Mounting Type Bracket

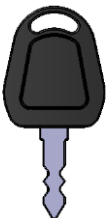

④ Key x 2



⑤ Desk Mounting Type Parts x 2

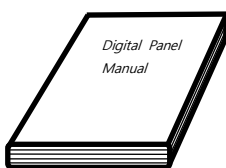

⑥ Manual

### Optional Accessories



① CCTV (Analog)



② Coaxial Cable (Shielded)

# 1. General Information

## 1.3 Product Specification

---

### Digital Panel Specification

No.	Item	Description
1	Microprocessor	<ul style="list-style-type: none"><li>• Cortex-A8, dsPIC33FJ256</li></ul>
2	Software	<ul style="list-style-type: none"><li>• Windows CE 6.0 R2</li></ul>
3	Display	<ul style="list-style-type: none"><li>• 10.2" Color TFT LCD</li><li>• 800 * 480 (Pixels)</li><li>• 16:9</li></ul>
4	Flash Memory	<ul style="list-style-type: none"><li>• 256MB (Flash)</li><li>• 8GB (MicroSD card)</li></ul>
5	RAM	<ul style="list-style-type: none"><li>• 512MB</li></ul>
6	Operating Voltage	<ul style="list-style-type: none"><li>• DC 24V (16 to 30V)</li></ul>
7	USB	<ul style="list-style-type: none"><li>• USB 2.0 1 Port</li></ul>
8	Operating Temperature	<ul style="list-style-type: none"><li>• - 20°C to 70°C</li></ul>
9	Internal Buzzer	<ul style="list-style-type: none"><li>• Piezo Buzzer 98dB</li></ul>
10	Communication	<ul style="list-style-type: none"><li>• J1939 CAN Communication</li><li>• RS232</li></ul>
11	Dimensions	<ul style="list-style-type: none"><li>• W 343.5 x H 270.5 x D 120</li></ul>

[Table 1-1]

## 2. Product Installation

### 2.1 Cautions

---

- Unskilled personnel should read this manual before use.
- Do not use or keep the product close to combustible sprays or inflammable.
- Use soft and dry cloth to clean the monitor.
- Turn off the product, pull out the harness cable and then contact our service center when you see smoke from the monitor or have strange smells.
- When you see an alarm on, you always need to check the product before operation.
- Do not disassemble the product cover at discretion (warranty does not cover unauthorized disassembly).
- Excessive impact may damage the display although a reinforced display is used.
- Use connectors matching each other when connecting them to the back of the product.
- Do not contact or remove connectors while the power is on. It may cause electric shock or lead to malfunction.
- Do not exercise excessive force when rotating to ON/OFF with the key inserted.
- Do not use the product with wet hands.
- Use protective caps for back side connectors that are not used.



## 2. Product Installation

### 2.3 Flush Mounting Type

- Flush Mounting types are installed in the bridge by using optional mounting brackets (2pcs).  
※ Bolt Spec: ① M6 ② M8, Length - 12mm



[Fig. 2-4] Flush Mounting Type Diagram

#### ▶ Installing Flush Mounting type digital panel

- ① Check whether the bridge has engine harness wiring.
- ② As shown in Fig. 2-6, fix the mounting brackets to both sides of the panel.
- ③ Check the location within reach of the engine harness wiring and the mounting location and then mount the panel using proper bolts.
- ④ Finish gaps between the product and the structure depending on the mounting conditions and connect the engine harness (you may connect the engine harness first depending on conditions).



[Fig. 2-5]

# 3. Part Names, Operation and Settings

## 3.1 Front

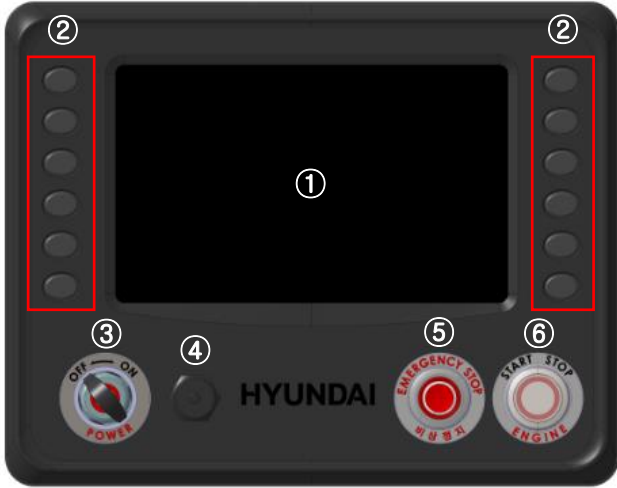

[Fig. 3-1]

No.	Name	Reference
①	LCD	-
②	Function Keys	Page 14
③	Key Switch	Page 12
④	USB	Page 12
⑤	Emergency Stop	Page 13
⑥	Start/Stop Button	Page 13

[Table 3-1]

## 3.2 Rear

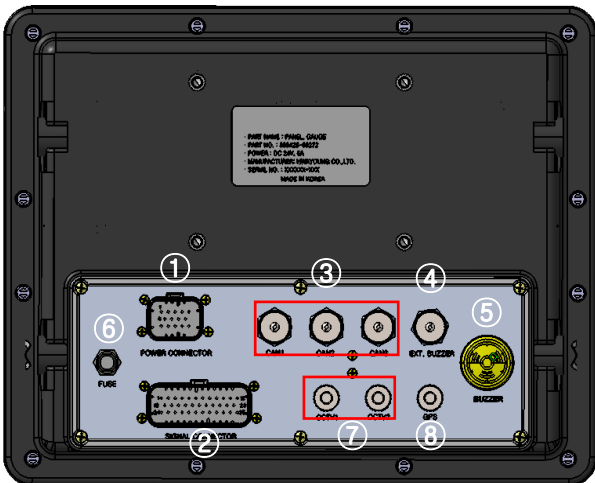

[Fig. 3-2]

No.	Name	Reference
①	Power Connector	Page 9
②	Signal Connector	Page 10
③	CAN/RS-232	Page 11
④	External Buzzer	Page 11
⑤	Built in Buzzer	Page 12
⑥	Fuse	Page 12
⑦	CCTV (Optional)	Page 11
⑧	GPS (TBD)	-

[Table 3-2]

# 3. Part Names, Operation and Settings

## 3.3 External Connection Terminals

---

- External connection terminals are used for inputs and outputs of engine control signals and each sensor signals.

### 3.3.1 Power Connector

- Power connector supplies power and power signals.

No.	Pin Description	Notes
1	Alternator In	Battery Voltage
2	-	-
3	Battery (+) (DC 24V)	Fuse Input
4		
5	Starter Signal	-
6	Valve Battery (+)	-
7	Valve Battery (+)	-
8	Starter Signal	-
9	Starter Signal	-
10	DC 12V Out	-
11	DC 5V Out	-
12	GND	Power
13	GND	
14	Battery (+) (DC 24V)	Fuse Input

[Table 3-3]



POWER CONNECTOR

[Fig. 3-3]

# 3. Part Names, Operation and Settings

## 3.3.2 Signal Connector

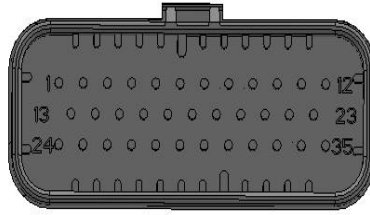

SIGNAL CONNECTOR

[Fig. 3-4]

No.	Pin Description	Notes	No.	Pin Description	Notes
1	Exhaust Gas Temperature Sensor 1 (+)	-	19	Spare Analog Input 3	-
2	Engine Water Temperature Sensor	-	20	Pickup Sensor (+)	-
3	Engine Oil Pressure Sensor	-	21	-	-
4	Engine Oil Temperature Sensor	-	22	-	-
5	*Boost Air Pressure Sensor	-	23	GND	Sensor
6	*Fuel Level Sensor	-	24	Valve Out	Valve Control Signal
7	Spare Analog Input 2	-	25	Exhaust Gas Temperature Sensor 2 (+)	-
8	Spare Analog Input 4	-	26	Exhaust Gas Temperature Sensor 2 (-)	-
9	Spare Digital Input 1	-	27	Valve Out	-
10	-	-	28	-	-
11	Fuel Leakage Switch	-	29	-	-
12	GND	Sensor	30	-	-
13	Exhaust Gas Temperature Sensor 1 (-)	-	31	-	-
14	Engine Water Pressure Sensor	-	32	-	-
15	Gearbox Oil Pressure Sensor	-	33	-	-
16	*Engine Water Level Sensor	-	34	-	-
17	*Boost Air Temperature Sensor	-	35	GND	Sensor
18	Spare Analog Input 1	-	-	-	-

\* Sensor for IMO Tier 3

[Table 3-4]

# 3. Part Names, Operation and Settings

## 3.3.3 CAN Communication Connector

- CAN harness (optional) connection
- CAN1 / CAN2 : for multi panels
- CAN3 : PC communication, firmware download

No.	CAN1	CAN2	CAN3
1	+12V Out	+12V Out	+12V Out
2	GND	GND	GND
3	CAN1_H	CAN1_H	CAN2_H
4	CAN1_L	CAN1_L	CAN2_L
5	Battery (+)	Battery (+)	PC_RXD1
6	GND	GND	PC_TXD1



[Fig. 3-5]

[Table 3-5]

## 3.3.4 External Buzzer Connector

- Additional connection for external buzzer harness
- Generating external buzzer alarms for warnings

No.	Name
1	Battery (+) – Fuse Output
2	Alarm Out

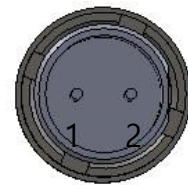

EXT. BUZZER

[Fig. 3-6]

[Table 3-6]

## 3.3.5 CCTV Connector (Optional)

- CCTV cable (optional) connection
- Installation available up to 2 devices with channels 1 & 2

No.	Name
1	CCTV Signal In

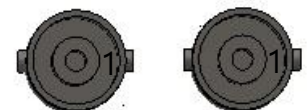

CCTV1 CCTV2

[Fig. 3-7]

[Table 3-7]

# 3. Part Names, Operation and Settings

## 3.3.6 USB Connector

- USB memory can be inserted for data backup.  
(Only FAT32 format available)



USB

[Fig. 3-8]

## 3.4 Fuse and Internal Buzzer

---

### 3.4.1 Fuse

- Shut down the power for overcurrent exceeding 6A
- Press the fuse button for 10 seconds to restore fuse operation.

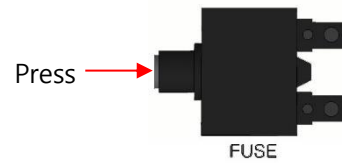

FUSE

[Fig. 3-9]

### 3.4.2 Internal Buzzer

- Generate alarms for sensor problems



BUZZER

[Fig. 3-10]

## 3.5 Key Switch

---

- Key switch is used to boot and turn off the digital panel system or stop the engine.

- 1) Use the key contained in the product to insert it and rotate to the right by 90° (ON) (when the key is ON, the key should remain inserted).
- 2) When the key is ON, the product will boot and the gauge display will appear in about 17 seconds.
- 3) Rotate the key to the left by 90° (OFF) to turn it off.
  - When rotating the key to the left (OFF) while the power is on, the display will show a popup message for 300 seconds. The engine will stop and the event will be saved after 300 seconds.
  - When the popup window appears, rotate the key to the right (ON) to remove the window and keep the engine on.

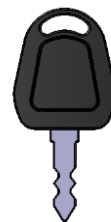

Key

[Fig. 3-11]

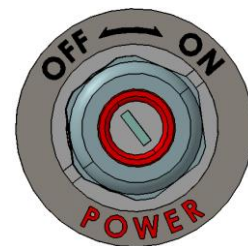

Key Switch

[Fig. 3-12]

## 3. Part Names, Operation and Settings

### 3.6 Start/Stop Button

---

- Start/Stop button is used to start/stop control for the engine.
  - 1) Press the button for more than 1 second while the key is ON, the engine will start (the button LED will flash when pressing the button).
  - 2) Press the button for more than 1 second while the key is ON and the engine is in operation to stop the engine.
    - ※ You can set the time to 1~3 second for emergency response in Digital Panel Manager.
    - ※ Plastic protection cover label installed.
    - ※ Be careful of strong force because it can be confirmed by LED flashing during pushing operation.

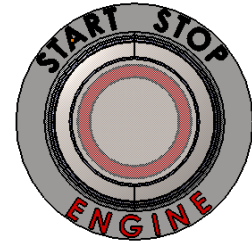

Start/Stop Button

[Fig. 3-13]

### 3.7 Emergency Stop Button

---

- Emergency Stop Button is used to urgent engine stop for the emergency situation.
  - 1) Press immediately when an emergency situation occurs in the engine run state.
    - Red LED on while pressing
  - 2) Engine RPM drops while depressed.
  - 3) Release the button after the engine is completely stopped.
    - LED off when released
    - ※ If you release the button before stopping the engine, the engine will restart.



Emergency Stop Button

[Fig. 3-14]

# 3. Part Names, Operation and Settings

## 3.8 Function Keys

- Function keys are used to adjust LCD brightness, stop alarming (mute), configure CCTV, Digit, Home and other settings, move to and select menus, and reset the system.

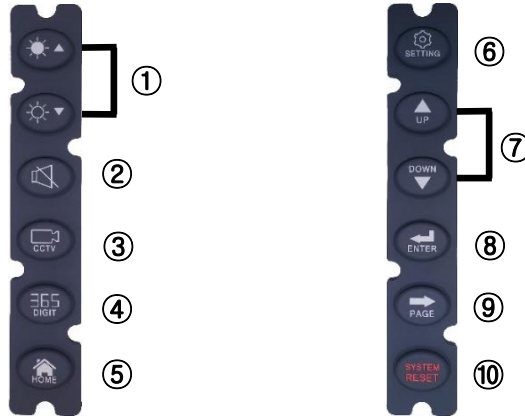

[Fig. 3-15] Function Keys

No.	Function Key	Action Feature
①	LCD dimmer	<ul style="list-style-type: none"> <li>• LCD brightness adjustable for 5 different levels (when rebooting the system, the previous setting will be maintained).</li> </ul>
②	Alarm Mute	<ul style="list-style-type: none"> <li>• Turn off the buzzer sound</li> </ul>
③	CCTV	<ul style="list-style-type: none"> <li>• Switching between CAM1 and CAM2 (optional)</li> </ul>
④	Digit On/Off	<ul style="list-style-type: none"> <li>• Default On</li> <li>• Press once : number light will be off</li> <li>• Press once again : number light will be on</li> </ul>
⑤	Home	<ul style="list-style-type: none"> <li>• Move to main gauge display.</li> <li>• Move to main display without saving when pressing it in page mode.</li> </ul>
⑥	Configuration	<ul style="list-style-type: none"> <li>• Engine Model setting</li> <li>• Master/Slave setting and ON/OFF setting to start the slave</li> <li>• ON/OFF setting for over speed testing</li> <li>• Oil Supply Mode</li> <li>• ON/OFF setting for spare sensor light</li> <li>• Select EGTS</li> <li>• USB backup and time (year/month/hour) settings</li> <li>• Convert Korean/English</li> <li>• Set date</li> </ul>
⑦	Up/Down	<ul style="list-style-type: none"> <li>• Move the cursor up and down in setting window</li> </ul>
⑧	Select	<ul style="list-style-type: none"> <li>• Select menus or functions in the setting window</li> </ul>
⑨	Page	<ul style="list-style-type: none"> <li>• Move to spare sensor display (display page 2) / Move to event summary display (display page 3)</li> </ul>
⑩	System Reboot	<ul style="list-style-type: none"> <li>• Rebooting for system errors (press it for more than 3 seconds to reboot)</li> </ul>

[Table 3-8]

### 3. Part Names, Operation and Settings

#### 3.8.1 Detailed Settings

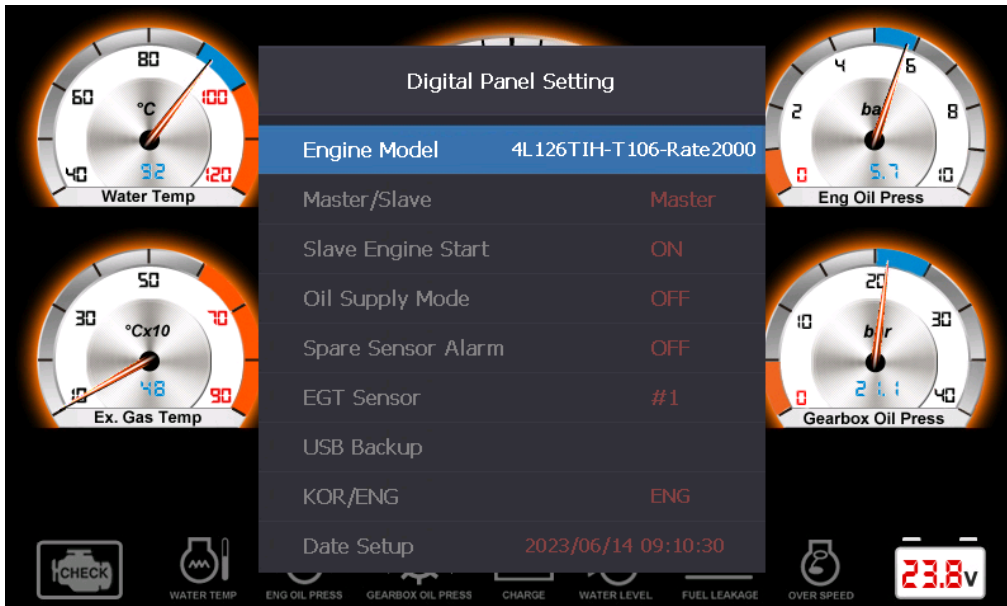

[Fig. 3-16] Detailed Settings

#### ▶ Setting Functions and Descriptions

- Press button and then use or button to move to functions to be changed.
- Press button to go back to gauge display (changes will be automatically saved).

No.	Function	Description	Function Key
1	Engine Model	• Engine model setting (refer to the appendix for the list of engine models)	
2	Master / Slave	• Master/Slave setting for multi panels	
3	Slave Engine Start	• ON/OFF setting to start from the slave	
4	Oil Supply Mode	• Supply Engine oil by idling	
5	Spare Sensor Alarm	• ON/OFF setting for spare check sensor light	
6	EGT Sensor	• Select Exhaust gas sensor number(for DX12)	
7	USB Back Up	• USB backup for event save files	
8	KOR/ENG	• Convert Korean to English	
9	Date Setup	• Date and time setting	

[Table 3-9]

### 3. Part Names, Operation and Settings

#### 3.9 Display Structure

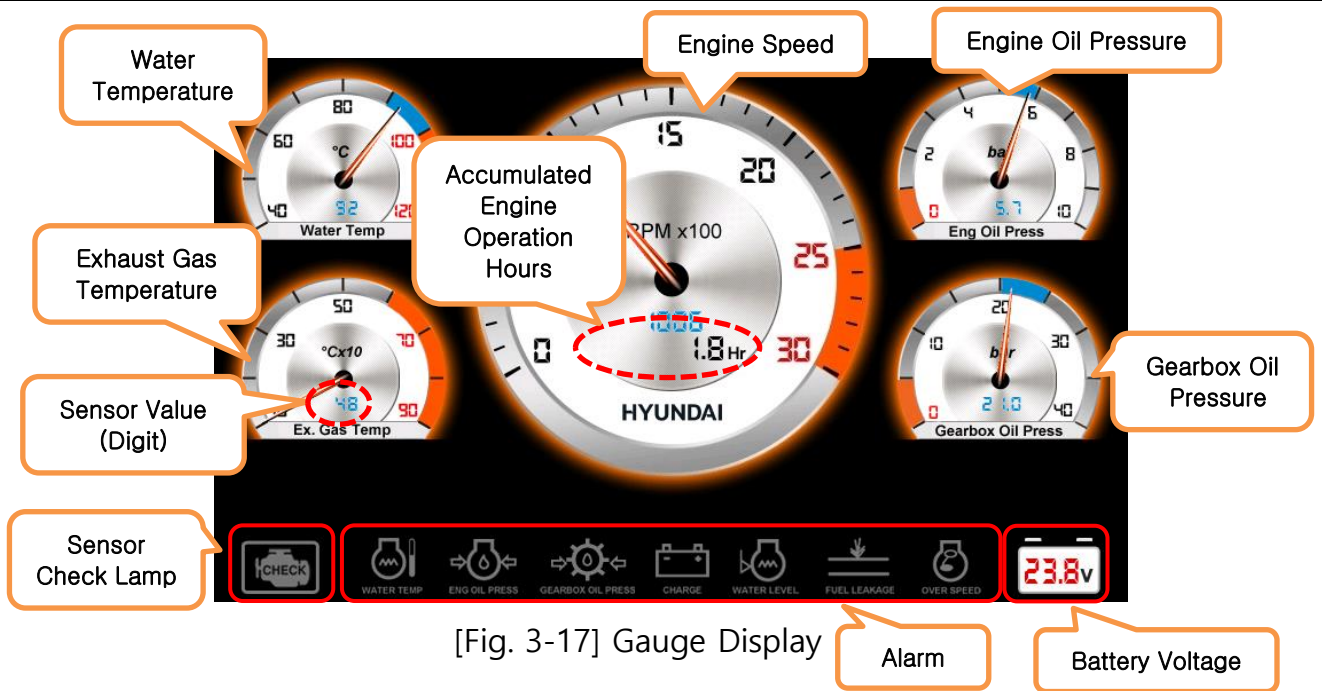

[Fig. 3-17] Gauge Display

- Gauge display shows various gauge data including pick up (RPM) sensor, coolant temperature, exhaust gas temperature, engine oil pressure and gearbox oil pressure.
- It also includes battery voltage indication, accumulated engine operation hours, coolant temperature, engine oil pressure, gearbox oil pressure, charging, fuel leakage and overspeed alarms.

##### 3.9.1 Engine Speed (Tachometer)

- It shows engine RPM in gauge and digital values and counts accumulated engine operation hours.



[Fig. 3-18]

Engine Speed Gauge

- 1) It shows the RPM indicated by the gauge hand in digital values (blue) for better accuracy (however, it is available off by the 'DIGIT' button).
- 2) It shows accumulated engine operation hours by hour unit (engine speed of 400RPM or faster will be counted and the function is always on)
- 3) Starter Off RPM setting is available between 300 and 600RPM after the engine starts (The service team can configure the setting in Digital Panel PC Manager).

### 3. Part Names, Operation and Settings

#### 3.9.2 Engine Water Temperature

- It shows the coolant temperature in gauge and digital values.



[Fig. 3-19]

Engine Water Temperature Gauge

- 1) It shows the temperature indicated by the gauge hand in digital values (blue) for better accuracy (however, it is available off by the 'DIGIT' button).
- 2) It shows the open/short diagnosis for sensor problems.  
☞ Open: 'ERROR' / Short (GND): '-----'
- 3) It also serves as the water temperature switch.
- 4) It activates alarm and warning beep when the temperature increases up to 93°C or higher.
- 5) When the temperature increases up to 103°C or higher, the engine will stop.

#### 3.9.3 Engine Oil Pressure

- It shows engine oil pressure in gauge and digital values.



[Fig. 3-20]

Engine Oil Pressure Gauge

- 1) It shows the pressure indicated by the gauge hand in digital values (blue) for better accuracy (however, it is available off by the 'DIGIT' button).
- 2) It shows the open/short diagnosis for sensor problems.  
☞ Open: '-----' / Short (Power): 'ERROR'
- 3) It also serves as the engine oil pressure switch.
- 4) It activates alarm and warning beep when the pressure is 1bar or lower (detects in 10 seconds).
- 5) When the pressure is 0.5bar or lower, the engine will stop(detects in 10 seconds).
- 6) Alarm won't work before the engine starts but at normal stop.

#### 3.9.4 Exhaust Gas Temperature

- It shows exhaust gas temperature in gauge and digital values.



[Fig. 3-21]

Exhaust Gas Temperature

- 1) It shows the temperature indicated by the gauge hand in digital values (blue) for better accuracy (however, it is available off by the 'DIGIT' button).
- 2) It shows the open/short diagnosis for sensor problems.  
☞ Open: 'ERROR' / Short (GND): '-----'
- 3) The alarm will be activated when the temperature is 600°C or higher while the engine is in operation.

### 3. Part Names, Operation and Settings

#### 3.9.5 Gearbox Oil Pressure

- It shows gearbox oil pressure in gauge and digital values.



[Fig. 3-22]

Gearbox Oil Pressure

- 1) It shows the pressure indicated by the gauge hand in digital values (blue) for better accuracy (however, it is available off by the 'DIGIT' button).
- 2) It shows the open/short diagnosis for sensor problems.  
 ☞ Open: '-----' / Short (Power): 'ERROR'
- 3) It activates alarm and warning beep when the pressure is 1bar or lower (detects in 10 seconds).

#### 3.9.6 Battery Voltage

- It shows battery voltage to indicate its conditions.



[Fig. 3-23] Battery Voltage

- 1) It will show in blue for voltage of 24V or higher or red for voltage lower than 24V.
- 2) It activates warning beep when the voltage is 20V or lower (regardless of whether the engine is in operation or not).

#### 3.9.7 Check Sensor Light

- When there are sensor errors (Open or Short), the check sensor light will turn on.



[Fig. 3-24] Check Sensor Light

※ Open and Short gauge displays for sensor problems



Open



Short

## 3. Part Names, Operation and Settings

### 3.9.8 Engine Alarms

- The alarm will be activated with buzzer beeping when problems for coolant temperature, engine oil pressure, gearbox oil pressure, charging, coolant level, fuel leakage and over speed are detected.



[Fig. 3-25] Engine Alarms

No.	Alarm	Action Feature
①	Coolant temperature	• Alarm (buzzer) will be activated when the temperature is <b>93°C</b> or higher
②	Engine oil pressure	• Alarm (buzzer) will be activated on when the pressure is <b>1 bar</b> or lower
③	Gearbox oil pressure	• Alarm (buzzer) will be activated on when the pressure is <b>1 bar</b> or lower
④	Charging	• Alarm (buzzer) will be activated when the battery voltage is lower than <b>18V</b>
⑤	Water level	• Alarm (buzzer) will be activated when the level is lower than <b>30%</b>
⑥	Fuel leakage	• Alarm (buzzer) will be activated when oil leak occurs (default setting is 'disabled')
⑦	Engine over speed	• Alarm (buzzer) will be activated when the speed exceeds <b>117%</b> of the rate speed

[Table 3-10] Alarm Features

※ How to deactivate the engine alarm

- Press SYSTEM RESET button on the right for 3 seconds, the system will reboot and the alarm will be deactivated (rebooting is available while the ship navigates without causing problems).

### 3.9.9 Engine Shutdown

- 1) When the over speed exceeds **117%** of the rate speed → Enable/Disable engine stop
- 2) When the coolant temperature exceeds **103°C** → Enable/Disable engine stop
- 3) When the oil pressure is **0.5bar** or lower → Enable/Disable engine stop
- 4) When fuel leakage occurs → Enable/Disable engine stop
- 5) Stop Valve → the stop button will be activated by users (when the engine continues at **0 RPM** for 7 seconds)

### 3. Part Names, Operation and Settings

#### 3.10 Spare Sensor

- It identifies the status of spare sensor, product S/N, F/W version, and date/time. Press  button of the function key to move to spare sensor page.

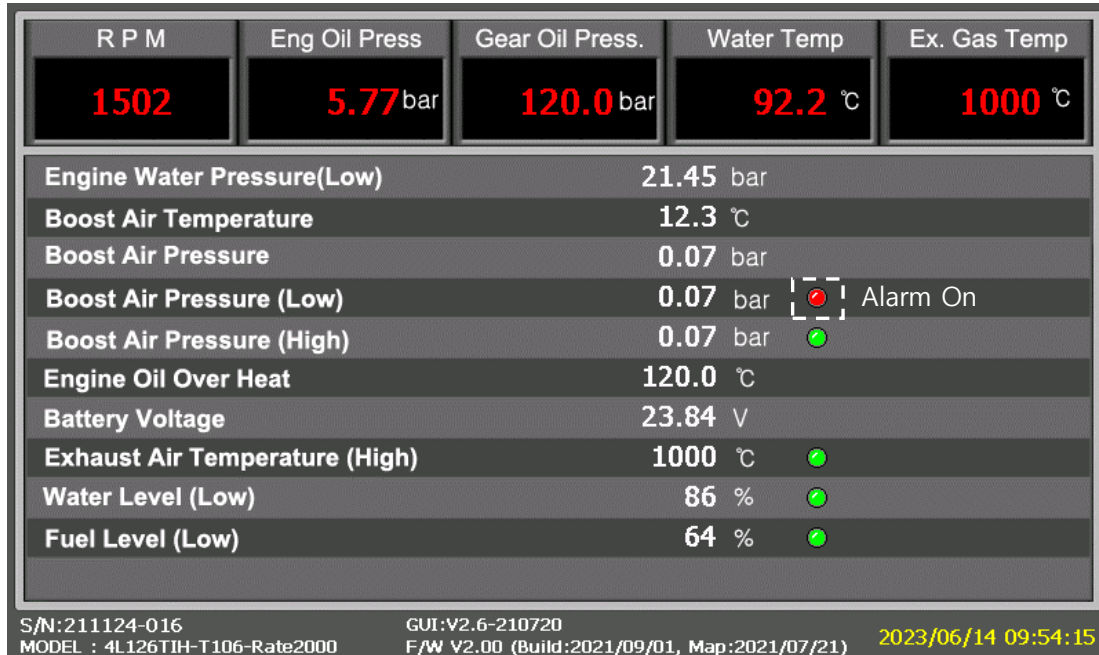

[Fig. 3-26] Spare Sensor and S/W information

Item	Condition
Gearbox Oil Pressure	• Alarm will be activated when the gearbox oil temperature is 1bar or lower
*Boost Air Temperature	• Current temperature
*Boost Air Pressure (Low)	• Alarm will be activated when the boost air pressure is 1bar or lower
*Boost Air Pressure (High)	• Alarm will be activated when the boost air pressure is 3bar or higher
*Engine Oil Over Heat	• Alarm will be activated when the engine oil temperature is 120°C or higher
Battery Voltage	• Current voltage
Exhaust Air Temperature (High)	• Alarm will be activated when the exhaust air temperature is 600°C or higher
*Water Level (Low)	• Alarm will be activated when the coolant level is 30% or lower
*Fuel Level (Low)	• Alarm will be activated when the fuel level is 30% or lower

\* Sensor for IMO Tier 3

[Table 3-11] Spare Sensor Conditions

### 3. Part Names, Operation and Settings

#### 3.11 Event Summary

- It shows the numbers of normal operations, normal stops, emergency stops and sensor errors together with dates of recent errors.
- Press  button in spare sensor page to move to event summary page.

Digital Panel Alarm Information			
Engine Run Count :	11	Engine ShutDown Count :	6
Engine Stop Count :	5		
Code	Description	OC	Alarm Date
P0101	Water Temp. Over Heat	2	2023/ 04/ 26/ 12: 35: 18
P0102	Low Engine Oil Pressure	10	2023/ 04/ 26/ 12: 36: 50
P0103	Low Gearbox Oil Pressure	1	2022/ 03/ 25/ 20: 01: 53
P0104	Battery Charge(alternator)	0	
P0105	Fuel Leakage (Switch)	0	
P0106	Over Speed	2	2023/ 04/ 26/ 12: 35: 07
P0107	Low Voltage	0	
P0108	Low Water Level	0	
P0109	Low Fuel Level	0	
P0110	Engine Oil Over Heat	0	
P0111	Main Connector Removed	0	
P0112	High Exhaust Gas Temperature	0	
P0113	Low boost Air Pressure	0	
P0114	High boost Air Pressure	0	
P0115	Abnormal Engine ShutDown	4	2023/ 06/ 14/ 08: 43: 20
P0116	Low Engine Speed	0	

[Fig. 3-27] Event Summary Screen

Event List			
P0101	Water Over Heat	P0109	*Low Fuel Level
P0102	Low Engine Oil Pressure	P0110	Engine Oil Over Heat
P0103	Low Gearbox Oil Pressure	P0111	Main Connector Removed
P0104	Battery Charge(Alternator)	P0112	High Exhaust Gas Temperature
P0105	Fuel Leakage(Switch)	P0113	*Low Boost Air Pressure
P0106	Over Speed	P0114	*High Boost Air Pressure
P0107	Low Voltage	P0115	Abnormal Engine Shutdown
P0108	*Low Water Level	P0116	Low Engine Speed

\* Sensor for IMO Tier 3

[Table 3-12] Event List

# 3. Part Names, Operation and Settings

## 3.12 System Booting and Functional Check

- You can check whether the product is properly installed or not.

### ▶ Normal System Booting

- 1) Insert the key into the key switch and rotate it to the right (ON).
- 2) HYUNDAI logo will appear for 17 seconds while the system is booting (refer to the image).
  - ※ If the logo does not appear after rotating the key,
    - Rotate it to the left (OFF) and then to the right (ON) again
    - Check the harness connection at the back of the panel
    - Check whether the battery is discharged
- 3) The gauge display will appear after normal booting.
  - Gauge: check whether each gauge hand is within the normal range and 'ERROR' or '-----' is displayed on the screen.
  - ※ Where 'ERROR' or '-----' is displayed on the screen
    - Check the harness connection
    - Function keys: check whether each function key is active on the screen by pressing them.
    - Alarm: check whether the alarm is turned on.
    - Battery: Check whether the battery is ok.
- 4) Where the initial gauge screen is normal, press START button for 1 second to start the engine (the time can be set to 1~3 second. Refer to Digital Panel Manager).
- 5) Check whether the operation is in normal RPM (initial operation in 400RPM or faster with the oil pressure of 1bar or higher) and whether is turned on.

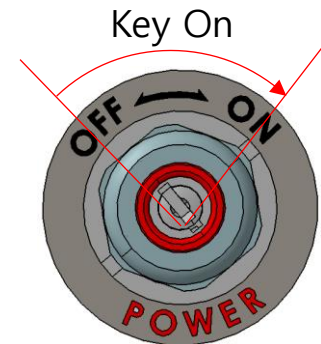

[Fig. 3-28] Key Switch



[Fig. 3-29] Booting Logo

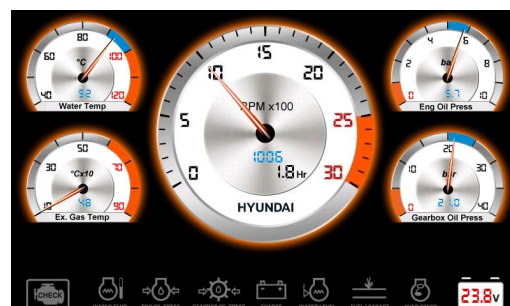

[Fig. 3-30] Gauge Display

# 4. Multi Panel Structure

## 4.1 Multi Panels

---

- Panels can be installed up to 4 units except Master in the ship and you can check the ship conditions and control those panels at any places of installation.

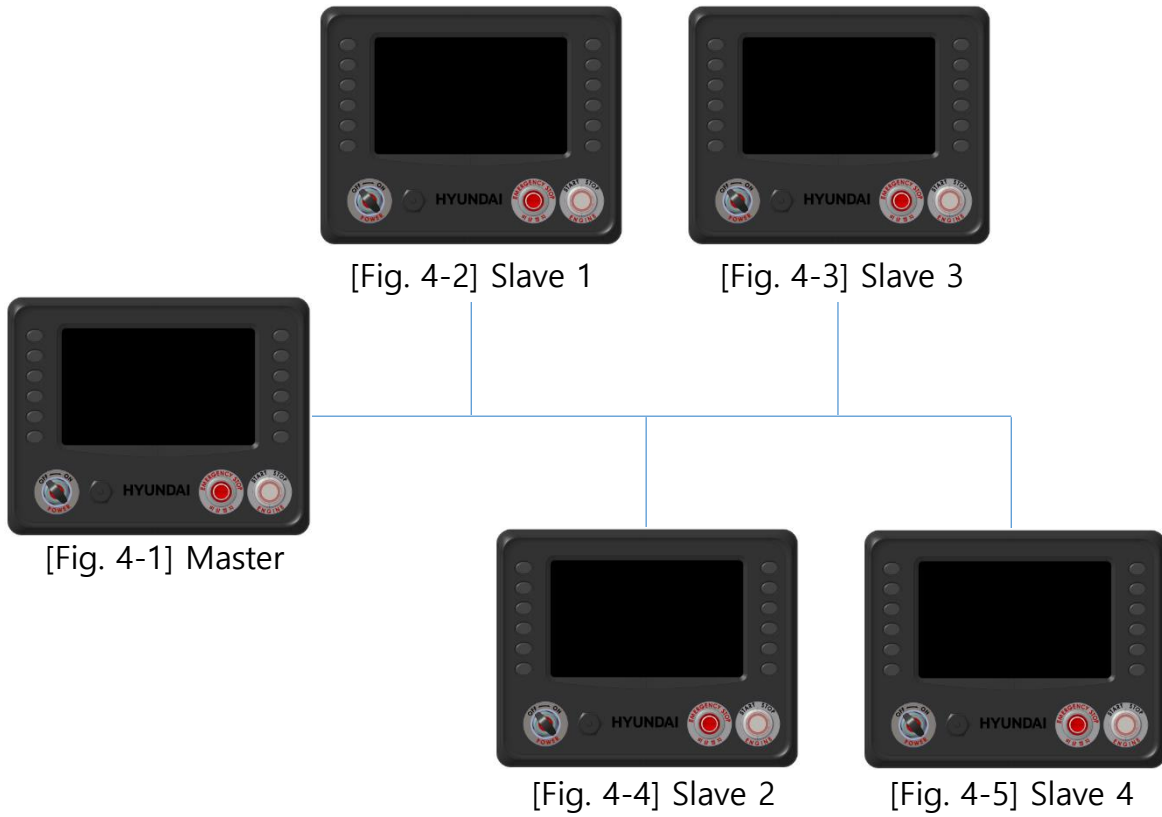

# 4. Multi Panel Structure

## 4.2 How to Install Multi Panels

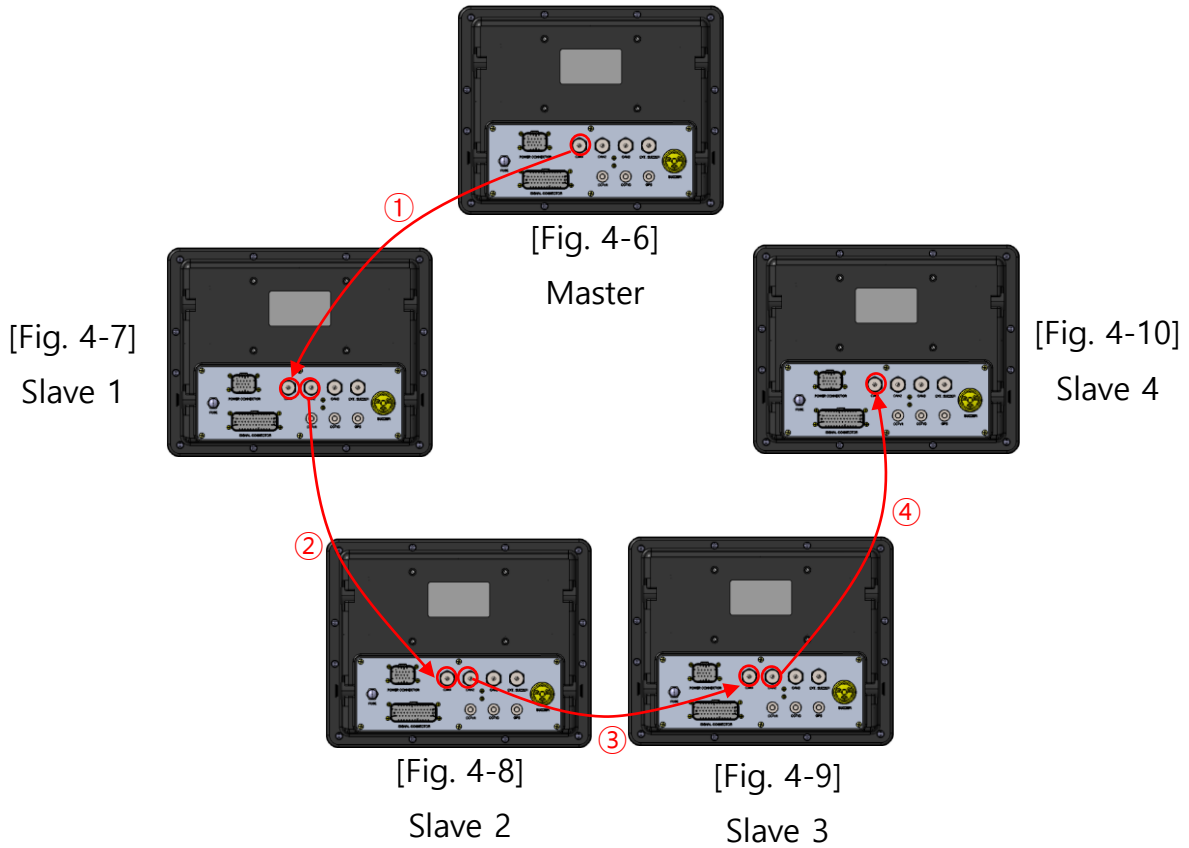

※ In order to install multi panels, all the necessary cables should be ready in advance (use the cables with specification recommended by HYUNDAI).

(1) Connect the CAN1 terminal of the Master panel and the CAN1 terminal of the Slave 1 panel as shown in ① (2 panels).

- Master and Slave 1 connection completed

(2) Connect Slave 1 (CAN2) and Slave 2 (CAN1) as shown in ② while maintaining connection as described in ① (3 panels).

- Master, Slave 1 and Slave 2 connection completed

(3) Connect Slave 2 (CAN2) and Slave 3 (CAN1) as shown in ③ while maintaining connection as described in ② (4 panels).





- Master, Slave 1, Slave 2 and Slave 3 connection completed

(4) Connect Slave 3 (CAN2) and Slave 4 (CAN1) as shown in ④ while maintaining connection as described in ③ (5 panels)

- Master, Slave 1, Slave 2, Slave 3 and Slave 4 connection completed

## 4. Multi Panel Structure

### 4.3 Multi Panel Settings

- (1) Press  button of the panel to be configured as Slave.
- (2) Move to ① when the setting screen appears (use  or  button to move).
- (3) Press  button to switch configuration between Master and Slave.
- (4) Configure the Master panel as described above.

※ Notes

- Master mode is available for one panel only and Slave mode is available up to 4 units.
- You can permit Slaves to start the engine with Master panel only. Where you enable Slave Engine Start setting, all Slave panels will be able to start the engine.

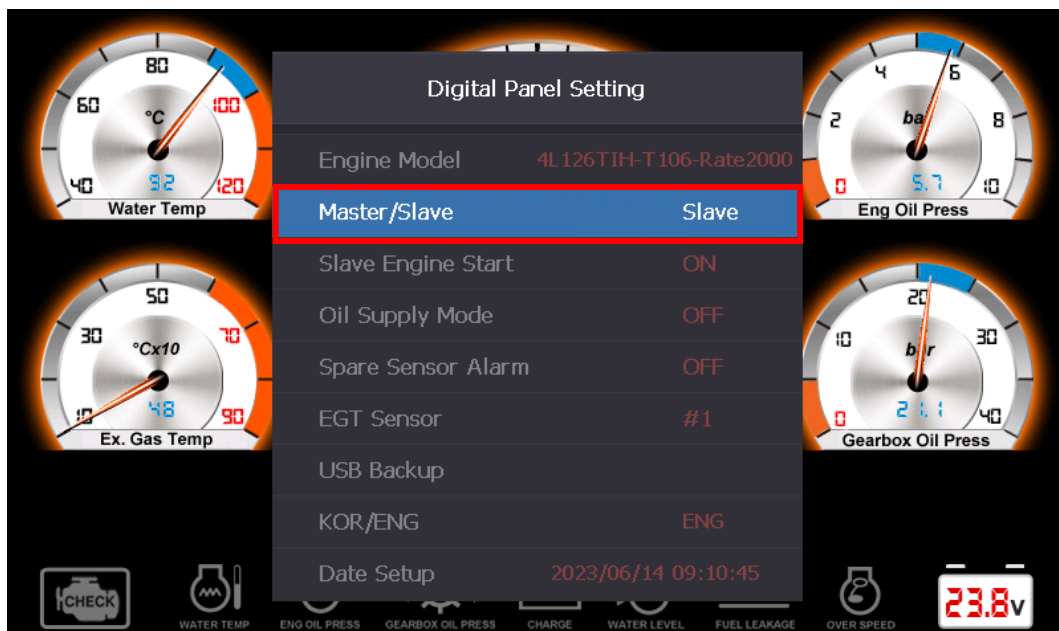

[Fig. 4-11] Multi Panel Setting Window

# 5. Maintenance

## 5.1 Maintenance

---

- To maintain the performance of the device, regular maintenance is required.
- 1. Use soft cloth to clean the LCD without damaging it.
  - 1) Clean the LCD after turning the power off.
  - 2) Do not use cleaners with acids or ammonia.
  - 3) Do not use neutral detergents to remove oil stains.
  - 4) Use cloth slightly wet in clean water to remove salt residuals or dust particles for natural drying. If there remain stains, clean them with soft cloth (microfibers) once again.
- 2. Check whether the connectors or harnesses at the back of the device are properly connected or whether they have dust or other foreign substances.
- 3. Check whether cables are damaged.
- 4. Request for checking when the software needs upgrade as follows:
  - When the manufacturer releases official software for performance improvements

## 5.2 Troubleshooting

---

- It describes possible measures for users to resolve problems while using the device.
- 1. The device is not turned on.
  - 1) Check whether harness cables at the back of the product are properly connected.
  - 2) Where harness cables have too much dust or moisture, remove them and clean the dust or moisture. Connect them once again after a while.
  - 3) Check whether the fuse button at the back of the product is pulled out.
  - 4) Check whether the battery is discharged.
- 2. You can see lines or shaking on the screen.
  - 1) Reboot the product.
  - 2) As the LCD is connected inside the product, do not disassemble it and contact the service team.
- 3. You can see distortions on CCTV screens.
  - 1) Check whether CCTV connectors or connectors at the back of the product are properly connected.
  - 2) Check whether cables are worn out.
- 4. You can see alarm or hear warning beeps at the bottom of the product screen.
  - 1) Check where the alarm occurs and then take measures as necessary (if you need to confirm which alarm occurs, refer to Page 20 of this manual).
- 5. You cannot control buttons.
  - 1) Check whether there are foreign substances at the panel buttons.
  - 2) As the button connecting parts may be damaged, do not disassemble the product and contact the service team.

## 6. Warranty and A/S Service

### 6.1 Warranty

---

As this manual contains important contents related to safety, use and maintenance of the product. So please read this manual carefully and then use the product in a proper manner.

Those who are not familiar with the product should keep this manual close to it.

We are not responsible for human injuries or property damages caused by the following reasons:

- Where you use the product for purposes other than the ones described in this manual
- Where you alter the product or its components at discretion
- Where you disassemble the product at discretion to resolve problems
- Where you use accessories or parts not supplied or recommended by us
- ※ Where you use accessories or parts manufactured by other companies, please contact our service center to check their compatibility.

### 6.2 A/S Service Information

---

- When you request A/S service, please let us know the model name, breakdown conditions and your contact information.
- Please ask the seller.

## 7. Appendix

### 7.1 List of Engine Models

- List of compatible engine models

Engine		Number of Gear Teeth	Rate Speed	Over Speed	
DB58TI	L066TIH	129	2,200	115%	2,530
D1146	L136	140	2,200	115%	2,530
D1146T	L136T	140	2,200	115%	2,530
	L136TL	140	2,500	115%	2,875
D1146TI	L136TI	140	2,200	115%	2,530
D1146TIB	L086TIH	140	2,200	115%	2,530
	L086TIM	140	2,300	115%	2,645
	L086TIL	140	2,500	115%	2,875
DE12T	MD196T	152	2,000	115%	2,300
DE12TI	MD196TI	152	2,000	115%	2,300
DE12TIB	L126TIH	152	2,000	115%	2,300
	L126TIM	152	2,100	115%	2,415
DX12	4L126TIH	106	2,000	117%	2,340
	4L126TIM	106	2,100	117%	2,415
	4L126TIL	106	2,200	117%	2,574
D2848LB	V158TIH	160	1,800	115%	2,070
	V158TIM	160	2,100	115%	2,415
	V158TIL	160	2,300	115%	2,645
D2840LB	V180TIH	160	1,800	115%	2,070
	V180TIM	160	2,100	115%	2,415
	V180TIL	160	2,300	115%	2,645
D2842LB	V222TIH	160	1,800	115%	2,070
	V222TIM	160	2,100	115%	2,415
	V222TIL	160	2,300	115%	2,645
4VD2848LB	4V158TIH	160	1,800	115%	2,070
	4V158TIM	160	2,100	115%	2,415
	4V158TIL	160	2,300	115%	2,645
4VD2842LB	4V222TIH	160	1,800	115%	2,070
	4V222TIM	160	2,100	115%	2,415
	4V222TIL	160	2,300	115%	2,645



# User Manual for 8 Inch Digital Panel and Controller for Mechanical Marine Propulsion Engine.

Ver.2.1



# HYUNDAI

# ► Contents

1. General Information		
1.1	Product Information	3
1.2	Components and Optional Accessories	3
1.3	Product Specification	4
2. Product Installation		
2.1	Cautions	5
2.2	Desk Mounting Type	6
2.3	Flush Mounting Type	7
3. Part Names, Operation and Settings		
3.1	Front Side	8
3.2	Back Side	8
3.3	External Connection Terminals	9
3.3.1	DGP 23Pin Main Connector	9
3.3.2	DACU 23Pin Main Connector	10
3.3.3	DACU 35 Pin Main Connector	11
3.3.4	Circular Interface Connector	12
3.3.5	USB Connector	12
3.4	Internal Buzzer	13
3.5	Key Switch	13
3.6	Emergency Start Button	14
3.7	Emergency Stop Button	14
3.8	Function Keys	15
3.8.1	Detailed User Settings	16
3.9	Display Structure	17
3.9.1	Engine RPM	17
3.9.2	Engine Cooling Water Temperature	18
3.9.3	Engine Oil Pressure	18
3.9.4	Exhaust Gas Temperature	18
3.9.5	Gearbox Oil Pressure	19
3.9.6	Battery Voltage	19
3.9.7	Check Sensor Light	19
3.9.8	Engine Alarm	20
3.9.9	Engine Stop	20
3.10	Spare Status	21

# ► Contents

3.11	Alarm Page	-----	22
3.12	System Booting and Functional Check	-----	23
4.	Multi Panel Structure		
4.1	Multi Panel	-----	24
4.2	How to Install Multi Panel	-----	25
4.3	Multi Panel Settings	-----	26
5.	Maintenance		
5.1	Maintenance	-----	27
5.2	Troubleshooting	-----	27
6.	Warranty and A/S Service		
6.1	Warranty	-----	28
6.2	A/S Service Information	-----	28
7.	Appendix		
7.1	List of Engine Model	-----	29



# 1. General Information

## 1.1 Product Information

This product is a digital panel for mechanical marine propulsion engines and can be applied to various small marine engines. The DACU (Data Acquisition Control Unit) acquires engine status data, and users can monitor the engine's status through the DGP (Digital Gauge Panel) feature. The product is designed with digital visualization to provide clear visibility of engine control and status information. It incorporates graphical analog gauges and digital displays to enhance user convenience and is designed to withstand harsh maritime environments.

## 1.2 Components and Optional Accessories

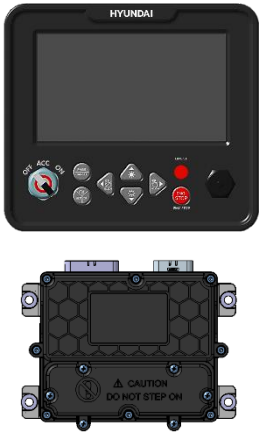
- Refer to Table 1-1 below for product components

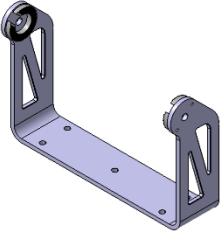
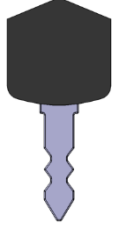
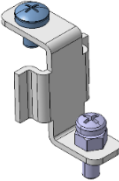
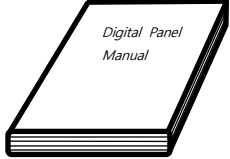
NO	Components	Component Name	NO	Components	Component Name
1		DGP  DACU	4		Desk Mounting Type Parts 1set
2		Desk Mounting Type Bracket	5		Key 2EA
3		Flush Mounting Type Bracket 4EA	6		User Manual

[Table. 1-1]

# 1. General Information

## 1.3 Product Specification

- Refer to Table 1-2 below for the hardware specifications of the digital panel for this mechanical engine.

### Digital Gauge panel product Specification

No.	Item	Remark
1	Microprocessor	<ul style="list-style-type: none"><li>• NXP4330Q / S32K144</li></ul>
2	Software	<ul style="list-style-type: none"><li>• Linux OS GUI + F/W</li></ul>
3	Display	<ul style="list-style-type: none"><li>• 8" Color TFT LCD</li><li>• 1280 * 720(Pixel)</li><li>• 16 : 9</li></ul>
4	Flash Memory	<ul style="list-style-type: none"><li>• 4GB(eMMC)</li></ul>
5	Ram	<ul style="list-style-type: none"><li>• 1GB</li></ul>
6	Operating Voltage	<ul style="list-style-type: none"><li>• DC 24V (9 ~ 32V)</li></ul>
7	USB	<ul style="list-style-type: none"><li>• USB 2.0 1Port</li></ul>
8	Operating Temperature	<ul style="list-style-type: none"><li>• - 20°C ~ 70°C</li></ul>
9	Internal Buzzer	<ul style="list-style-type: none"><li>• Piezo Buzzer 98dB</li></ul>
10	Communication	<ul style="list-style-type: none"><li>• J1939 CAN communication</li><li>• RS232</li></ul>
11	Dimensions	<ul style="list-style-type: none"><li>• W 287 x H 245.8 x D 108.15(DGP)</li><li>• W 236 x H 186.6 x D 80(DACU)</li></ul>

[Table 1-2]

## 2. Product Installation

### 2.1 Cautions

---

- Unskilled personnel should read this manual before use.
- Do not use or keep the product close to combustible sprays or inflammable.
- Use soft and dry cloth to clean the panel LCD.
- Turn off the product, pull out the harness cable and then contact our service center when you see smoke from the panel or have strange smells.
- When you see an alarm on, you always need to check the product before operation.
- Do not disassemble the product cover at discretion (warranty does not cover unauthorized disassembly).
- Excessive impact may damage the display although a reinforced display is used.
- Use connectors matching each other when connecting them to the back of the product.
- Do not contact or remove connectors while the power is on. It may cause electric shock or lead to malfunction.
- Do not exercise excessive force when rotating to ON/OFF with the key inserted in.
- Do not use the product with wet hands.
- Put protective caps on back side connectors when they are not in use.

## 2. Product Installation

### 2.2 Desk Mounting Type

- ※ Desk Mounting Types are installed in the Bridge or engine room by using desk mounting brackets delivered with the product.
- ※ Mounting Hole Spec: M6 bolt

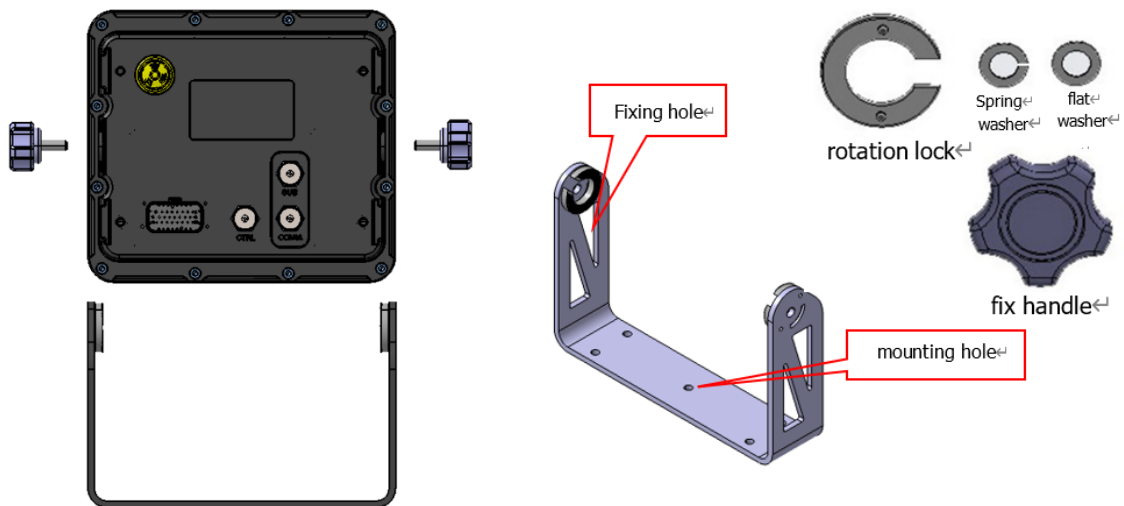

[Fig. 2-1] Desk Mounting Type Diagram

#### ▶ Installing Desk Mounting Type digital panel

- ① Check if there is cable wiring available in the Bridge or engine room.
- ② Fix the bracket using mounting hole of the product at the position where the cable wiring reaches.
- ③ Place the product inside the bracket connected with the rotation lock to connect it with the rotation lock.
- ④ Connect it with the fix handle to the direction indicated by an arrow and adjust the viewing angle of the LCD

※ Where there are things to which the product can be fixed, use spare holes with the bolt or other accessories.

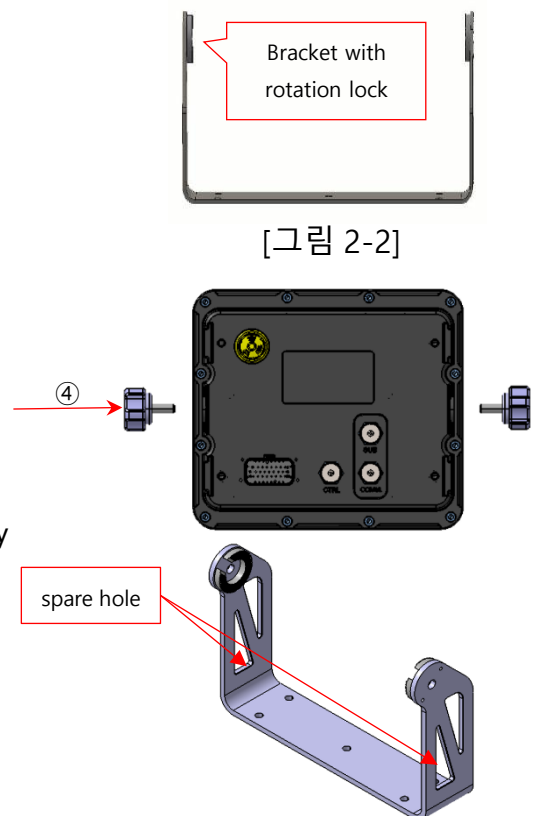

[Fig. 2-3]

## 2. Product Installation

### 2.3 Flush Mounting Type

- Flush Mounting types are installed in a Bridge or engine room by using optional mounting brackets (2pcs).

※ Bolt Spec: ① M6 X 10L ② M6 X 20L

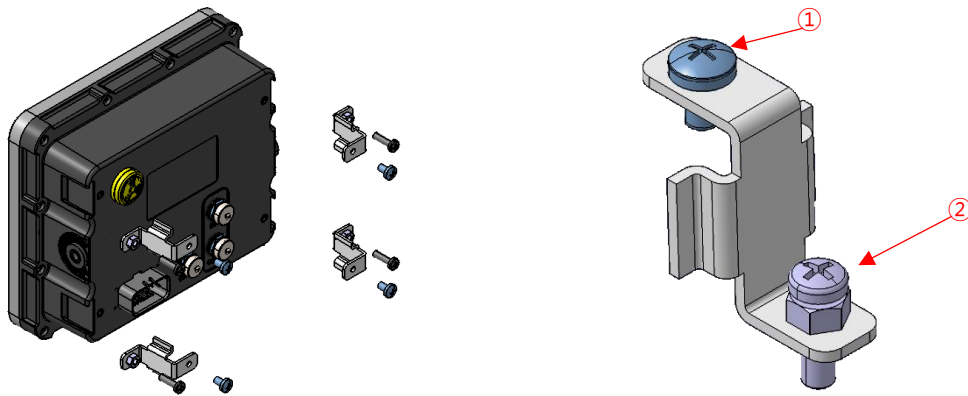

[Fig. 2-4] Flush Mounting Type Diagram

#### ► Installing Flush Mounting Type digital panel

- ① Check the harness is wired in the Bridge or engine room.
- ② As shown in [Fig. 2-5], fix the mounting brackets to both sides of the panel.
- ③ Check the location within reach of the harness wiring and the mounting location and then mount the panel using proper bolts.
- ④ Finish gaps between the product and the structure depending on the mounting conditions and connect the engine harness (you may connect the engine harness first depending on conditions)

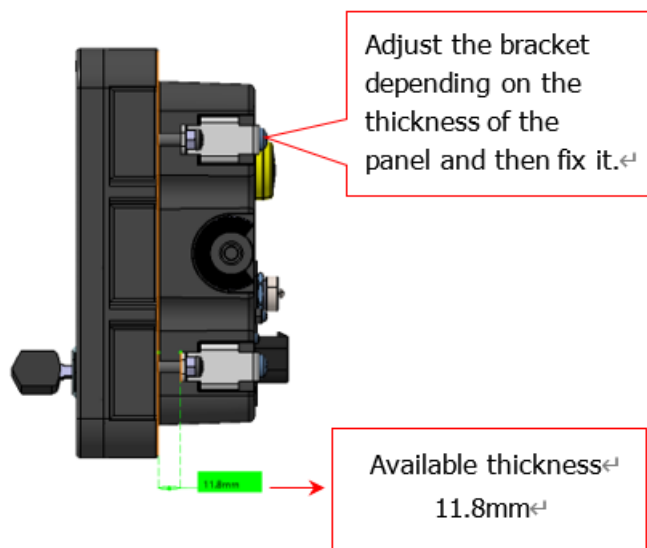

[Fig 2-5]

# 3. Part Names, Operation and Settings

## 3.1 Front Side



[Fig. 3-1]

No.	Name	Reference
①	LCD	-
②	Function Keys	13 Page
③	Key Switch	11 Page
④	USB	10 Page
⑤	Emergency Stop Switch	12 Page
⑥	Emergency Start Switch	12 Page

[Table. 3-1]

## 3.2 Back Side

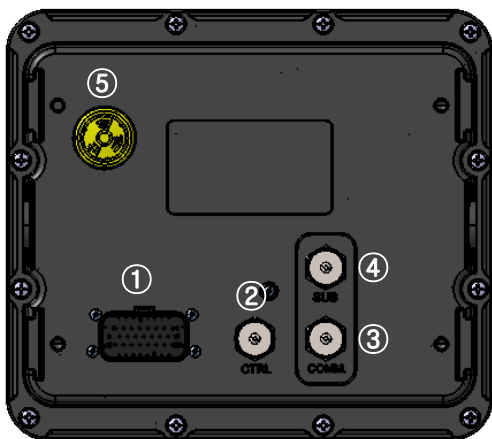

[Fig. 3-2]

No.	Name	Reference
①	Main Connector	9 Page
②	Engine Control (External Buzzer and Function for Ship Generator)	12 Page
③	COMM.	12 Page
④	SUB	12 Page
⑤	Internal Buzzer	13 Page

[Table. 3-2]

# 3. Part Names, Operation and Settings

## 3.3 External Connection Terminals

- Input/output connector connecting DGP and DACU
- Input/output connector for various control signals including sensors between DACU and engine

### 3.3.1 DGP 23Pin Main Connector

- Interface connector for receiving power and engine operation information from DACU and transmitting and receiving CAN signals with ECU (For Ship Generator)

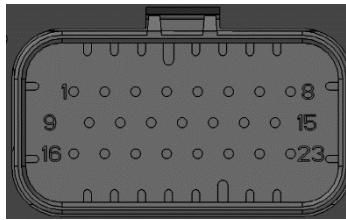

[Fig. 3-3]

No.	Pin Description	Notes	No.	Pin Description	Notes
1	Battery In	-	13	(opt) PC RXD1	-
2	Battery In	-	14	(opt) PC TXD1	-
3	Power GND	-	15	Alternator In	Electronic panel only
4	Power GND	-	16	Wait to Disconnect Signal	
5	Key On	-	17	Wait to Disconnect Common	
6	Starter Signal	-	18	Gearbox Oil Pressure Supply	
7	Emergency Switch Power	-	19	Gearbox Oil Pressure Signal	
8	Emergency Switch Signal	-	20	Fuel Leakage Switch	
9	CAN 1 High	-	21	GND Sensor	
10	CAN 1 Low	-	22	Water In Fuel Switch	
11	(opt) CAN 2 High	Option	23	GND Sensor	
12	(opt) CAN 2 Low		-	-	

[Table 3-3]

### 3. Part Names, Operation and Settings

#### 3.3.2 DACU 23Pin Main Connector

- Interface connector to provide DGP power and engine operation information

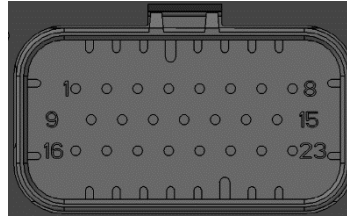

[Fig. 3-4]

No.	Pin Description	Notes	No.	Pin Description	Notes
1	CAN 1 Low	-	13	Power GND	-
2	CAN 1 High	-	14	DSC RPM Pick-up (GND)	Generator only
3	(opt) CAN 2 High	-	15	DSC Actuator A	Generator only
4	(opt) PC TXD1	-	16	Battery In	-
5	Key On	-	17	DSC CAN 2 Low	Generator only
6	Starter Signal	-	18	DSC CAN 2 High	Generator only
7	DSC RPM Pick-up Signal	Generator only	19	Emergency Switch Signal	
8	DSC Battery	Generator only	20	Emergency Switch Power	
9	Battery In	-	21	Power GND	
10	(opt) CAN 2 Low	-	22	DSC GND	
11	(opt) PC RXD1	-	23	DSC Actuator B	Generator only
12	-	-			

[Table. 3-4]

# 3. Part Names, Operation and Settings

## 3.3.3 DACU 35Pin Main Connector

- Engine harness interface connector that is connected to the engine harness to receive power and analog sensor information of the engine and supply start control signals to the engine

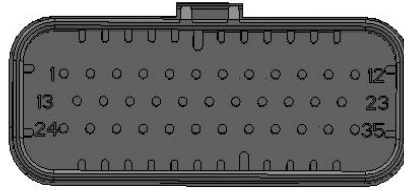

[Fig. 3-5]

No.	Pin Description	Notes	No.	Pin Description	Notes
1	Alternator In	-	19	Water Pressure Signal	-
2	Stop Solenoid Signal	-	20	Stop Solenoid Power	-
3	Fuel Leakage Switch	-	21	Starter Motor Power	-
4	Engine Oil Temp Signal	-	22	-	-
5	Exhaust Gas Temp2+	-	23	Power GND	-
6	Exhaust Gas Temp1+	-	24	DSC Actuator B	Generator only
7	Engine Oil Pressure Signal	-	25	RPM Pick-up Signal	
8	Stop Solenoid Power	-	26		
9	Starter Motor Power	-	27		
10	Starter Motor Power	-	28		
11	Power GND	-	29		
12	Power GND	-	30	GND Sensor	
13	DSC Actuator A	Generator only	31	GND Sensor	
14	RPM Pick-up (GND)		32	Stop Solenoid Power	
15	Water Temp Signal	-	33	Battery In	
16	Exhaust Gas Temp2-	-	34	Battery In	
17	Exhaust Gas Temp1-		35	Battery In	
18	Gearbox Oil Pressure Signal	-	-		

[Table. 3-5]

# 3. Part Names, Operation and Settings

## 3.3.4 Circular Interface Connector

- CTRL : Buzzer output connector for external buzzer connection
- COMM. : Multi-panel[OUT], communication connector for power and CAN communication
- SUB : Multi-panel[IN], communication connector for power and CAN communication

No.	CTRL	COMM.	SUB
1	Buzz Battery	Key On	Key On
2	Buzz Out	Battery In	Battery In
3	VCC	CAN2 H	CAN2 H
4	RPM_TRIM	CAN2 L	CAN2 L
5	GND	CAN1 H	CAN1 H
6	ISO_AUX+	CAN1 L	CAN1 L
7	ISO_AUX-	GND	GND
8	GND	-	-

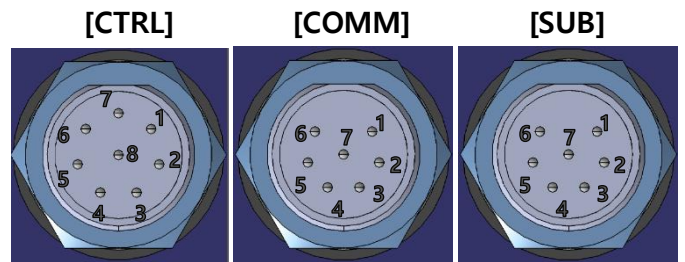

[Fig 3-6]

[Table. 3-6]

## 3.3.5 USB Connector

- When backing up driving record data and upgrading software, insert a USB memory (FAT32 format is used)

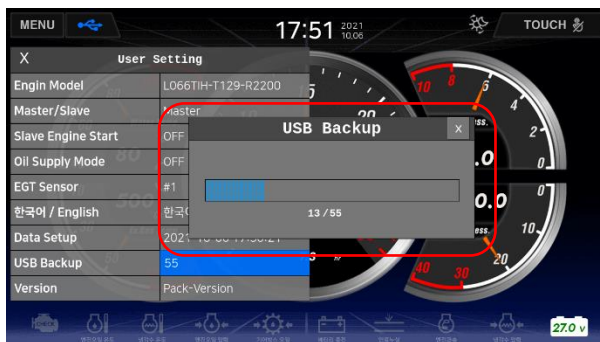

[Fig. 3-7-1]



[Fig. 3-7-2]

## 3. Part Names, Operation and Settings

### 3.4 Internal Buzzer

---

- Buzzer sound when an alarm occurs due to engine abnormality
- It operates at 98dB, and an external large-capacity buzzer can be additionally installed.



[Fig. 3-8]

### 3.5 Key Switch

---

- Digital panel system boot, engine start, and engine stop functions.
  - 1) After inserting the key included in the product in the key switch and turning it to the position of 45° to the right (ACC), the product is booted.
  - 2) Engine starts at the position of 90° turn (ON) and it returns to 45° position (If the key is in the ON state, keep the key lock state)
  - 3) When ACC is ON, the product boots within 5 seconds and the gauge screen is output after the introduction screen.
  - 4) Turn the key 45° to the left (OFF) when the engine is stopped

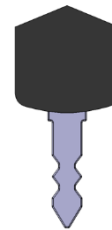

Key  
[Fig. 3-9]



Key Switch  
[Fig. 3-10]

## 3. Part Names, Operation and Settings

### 3.6 Emergency Start Button

---

- Used to force the engine to start in an emergency situation.
  - 1) In the OFF state of the key, rotate the key to ON while pressing it with an available device for the buttonhole.
    - ※ Application of safety accident prevention function
    - ※ Hole Size : Ø7
  
- ※ It should be used only in emergency situations and product life may be affected when used.



EMG. Start Button  
[Fig. 3-11]

### 3.7 Emergency Stop Button

---

- Used to stop the engine in an emergency situation
  - 1) Press immediately in case of emergency with engine running.
    - Stop solenoid actuation while pressing and warning beep.
  - 2) Engine RPM decreases while pressed
  - 3) Release the press when the RPM drop
  
- ※ If the button is released within a short period of time, the engine may not be stopped
- ※ Emergency stop should only be used in emergency situations, as it can potentially impact the lifespan of the product.



**EMG.STOP**

EMG. Stop Button  
[Fig. 3-12]

### 3. Part Names, Operation and

#### 3.8 Function Keys

- Functions such as panel setting, alarm stop, menu movement and selection.

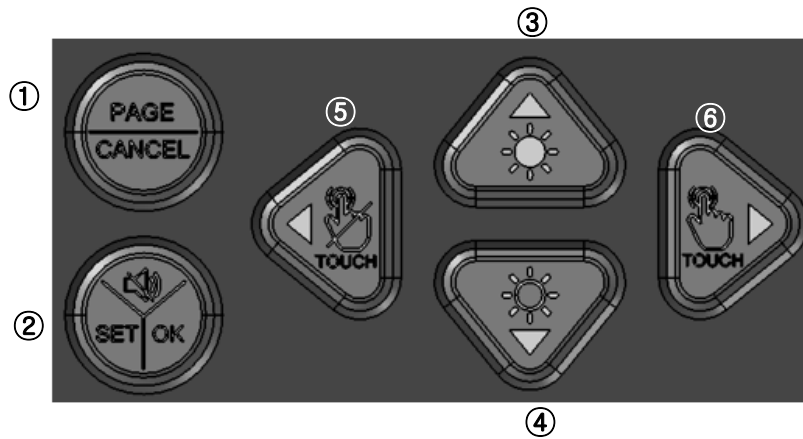

[Fig. 3-13] Function Keys

NO.	Function	Action Characteristics
①	Page	• Switch page / cancel
②	Ok	• Enter setting, save setting value
③	Up	• Cursor movement (up), setting value change (increase), screen brightness increase
④	Down	• Cursor movement (down), setting value change (decrease), screen brightness decrease
⑤	Left	• Cursor movement (left), Lock LCD touch function
⑥	Right	• Cursor movement (right), unlock LCD touch function

[Table. 3-7]

### 3. Part Names, Operation and Settings

#### 3.8.1 Detailed User Setting



[Fig. 3-14] Detailed Settings

#### ► User Setting Function and Description

- Press and hold the settings button for 3 seconds on the main screen to enter the user settings.
- Use the arrow keys to move to the function you want to change.
- Press the Ok button to go to the gauge screen. (Auto save on change)

No.	Function	Description	Remark
1	Engine Model	• Setting the Engine Model Installed on the Ship	-
2	Master / Slave	• Master / Slave setting when using multi-panel	-
3	Slave Engine Start	• Slave start authorization On / Off	-
4	Oil Supply Mode	• On / Off function for lubrication inside the engine at idle • Can be set for a total of 5 seconds in 1 second increments	-
5	EGT Sensor	• Exhaust gas temperature sensor selection (for DX12 engine)	-
6	Korean/English	• Korean / English conversion	-
7	Date Setup	• Set date and time	-
8	USB Back up	• Backup event and driving history files to USB	-
9	Version	• Show as full integrated version of software	Select S/W update item

[Table. 3-8]

### 3. Part Names, Operation and Settings

#### 3.9 Screen Layout

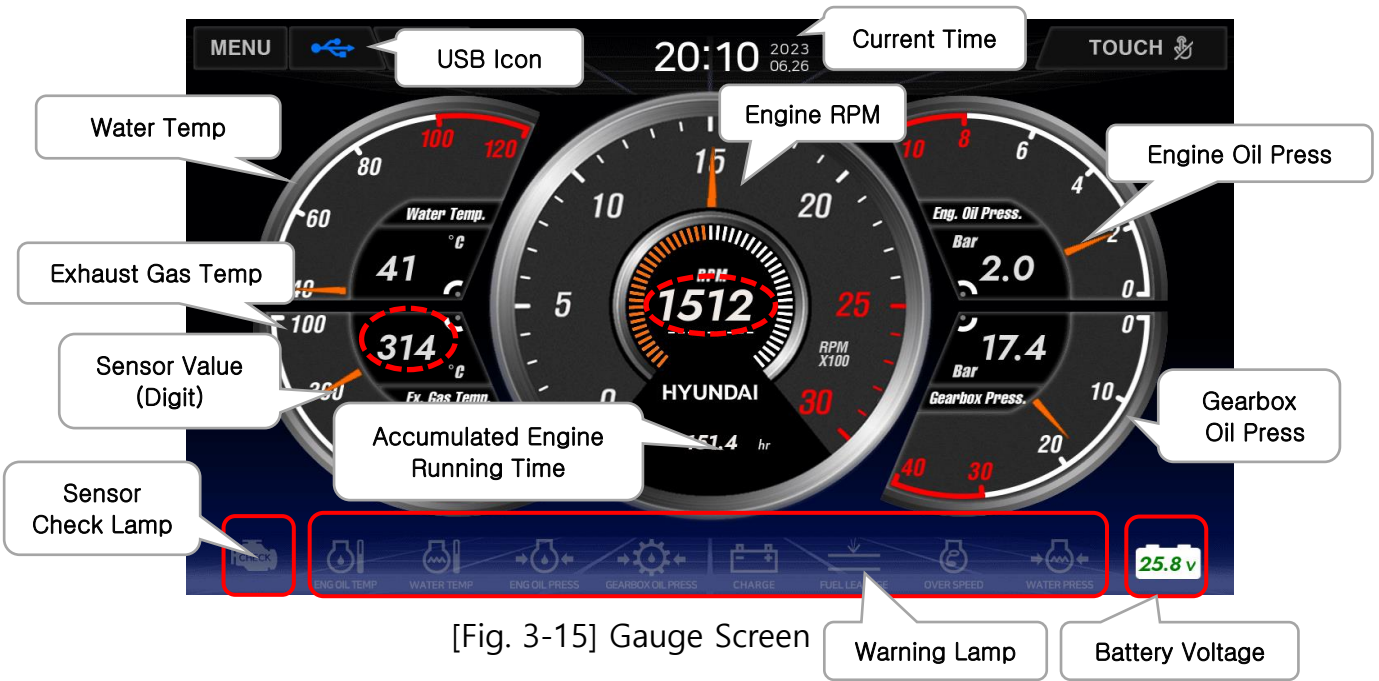

- The gauge functions include engine RPM, coolant temperature, exhaust gas temperature, engine oil pressure, gearbox oil gauge and more.
- Current time, USB detection icon, battery voltage, engine operation accumulated time, high coolant temperature, low engine oil pressure, overspeed, charging, CAN communication abnormality, moisture detection, fuel leakage and gearbox oil gauge warning lights.

#### 3.9.1 Engine RPM

- The engine rpm is displayed as a gauge and a digital value, and the accumulated engine running time is counted.



[Fig. 3-16] Speed Gauge

- 1) The rpm value indicated by the needle is expressed more precisely as a digital number (digit) (The digit is always ON)
- 2) Displays the accumulated engine running time in 1hour increments.  
(Counts over 400rpm and is always on)
- 3) After starting the engine, Starter Off RPM 300 ~ 500rpm can be set

## 3. Part Names, Operation and Settings

### 3.9.2 Engine Cooling Water Temperature

- Cooling water temperature is displayed digitally with a gauge.



[Fig. 3-17]

#### Engine Cooling Water Temperature

- 1) The temperature of the coolant pointed to by the needle is more precisely expressed as a digital number (digit)  
(The digit is always ON)
- 2) In case of sensor failure, open/short diagnosis is displayed.
- 3) Warning lamp and warning sound when starting state is over 93°C
- 4) Stop the engine when the starting state is over 103 °C

### 3.9.3 Engine Oil Pressure

- Displays engine oil pressure with gauge and digital.



[Fig. 3-18]

#### Engine Oil Pressure Gauge

- 1) The oil pressure value indicated by the needle is more precisely expressed as a digital value (digit) (The digit is always ON)
- 2) In case of sensor failure, open/short diagnosis is displayed.
- 3) Warning light and warning sound when less than 1 bar  
(Detected when holding for 10 seconds)
- 4) Engine stop when less than 0.5 bar  
(Detected when holding for 10 seconds)
- 5) Alarm does not work before starting, but alarm works when normal engine stops

### 3.9.4 Exhaust Gas Temperature

- Displays exhaust gas temperature with gauge and digital.



[Fig. 3-19]

#### Exhaust Gas Temperature

- 1) Express the exhaust gas temperature pointed by the needle more precisely as a digital number (digit)  
(The digit is always ON)
- 2) In case of sensor failure, open/short diagnosis is displayed.
- 3) Preliminary sensor warning light operates when the starting state is over 600 °C

# 3. Part Names, Operation and Settings

## 3.9.5 Gearbox Oil Pressure

- Displays gearbox oil pressure with gauge and digital.



- 1) The gearbox oil pressure value indicated by the needle is more precisely expressed as a digital value (digit)
- 2) Diagnose open or short circuit when a sensor malfunction occurs.
- 3) When the ignition state is below 1 bar, a warning light and alarm sound are activated (if detected for more than 10 seconds).

[Fig. 3-20]

Gearbox Oil Pressure

## 3.9.6 Battery Voltage

- Displays the battery voltage to inform you of the battery status.



[Fig. 3-21] Battery Voltage

- 1) Green for more than 24V / Red for less than 24V
  - 2) Fault code P0562 and warning sound when battery is low voltage
- ➔ Low battery voltage

## 3.9.7 Check Sensor Light

- When a sensor error (open, short) occurs or communication fault between DACU and Sensors, the sensor check light turns on.



- 1) When a sensor error occurs, the check light turns on in red.
- 2) Lights orange when an error has ended.

[Fig. 3-22] Check Sensor Light

※ In case of engine oil pressure sensor failure, open or short gauge screen is displayed.



Open

Short

[Fig. 3-23] Check Sensor Light

### 3. Part Names, Operation and Settings

#### 3.9.8 Engine Alarm

- In case of coolant temperature, engine oil pressure, gearbox oil pressure, charging, moisture detection, overspeed, or fuel leakage, warning lights flash and a buzzer sound.



[Fig. 3-24] Engine Alarm

NO.	Alarm	Action Characteristics
①	Water Temperature	• Warning light (buzzer) On when over 93°C
②	Engine Oil Pressure	• Warning light (buzzer) On when less than 1 bar
③	Gearbox Oil Pressure	• Warning light (buzzer) On when less than 1 bar
④	Charge	• Warning light (buzzer) On when battery voltage is less than about 18V
⑤	Fuel Leakage	• Warning light (buzzer) on in case of fuel leakage (Default: Disable)
⑥	Over Speed	• Warning light (buzzer) On when over 117% of Rate Speed

[Table. 3-9] Warning light characteristics

#### 3.9.9 Engine Stop

- 1) When engine overspeed is more than 117% of Rate Speed → Enable/Disable engine stop
- 2) When the coolant temperature is over 103°C → Enable/Disable engine stop
- 3) When the engine oil pressure is kept less than 0.5 bar for more than 10 seconds → Engine stop Enable/Disable possible
- 4) When fuel leakage occurs → Engine stop Enable/Disable possible
- 5) When activated Stop Valve → Stop Button is actuated by the user (at 0 RPM for 7 seconds)

※ How to turn off the engine warning light

- When the alarm condition is cleared and it is maintained for 3 seconds, the buzzer and lamp are automatically released and the lamp changes to orange color

### 3. Part Names, Operation and Settings

#### 3.10 Spare Sensor

- It displays the status of other sensors, product S/N, ECU MAP VERSION, and GUI/FIRMWARE version. Pressing the menu key among the function keys moves to the spare sensor page.



[Fig. 3-25] Spare Sensor (Including Classification Applied Sensor) Information

Item	Action Characteristics
Exhaust Gas Temperature1 (High)	• Warning light turns on when exhaust temperature is over 600°C
Exhaust Gas Temperature2 (High)	• Warning light turns on when exhaust temperature is over 600°C
Water Pressure	• Warning light turns on when coolant pressure is less than 0.2 bar
Engine Oil Over Heat	• Warning light turns on when engine oil exceeds 120°C

[Table. 3-10] Spare Sensor

### 3. Part Names, Operation and Settings

#### 3.11 Alarm Page

- The number of normal starts / number of normal stops / number of abnormal stops / number of emergency starts / number of emergency stops accumulated number of sensor alarm occurrences and information of the latest date of alarm are displayed in the digital panel itself.
- If you press the menu button on the other sensor page, the screen switches to the event summary page.

The screenshot shows a digital panel interface with a top status bar containing 'MENU', 'READY', a large digital clock '15:39' with date '2023 02.15', and 'TOUCH' with a microphone icon. Below the status bar are five status indicators: 'ENG.RUN 0', 'ENG.STOP 0', 'ENG.Shutdown 0', 'EMG.START 0', and 'EMG.STOP 0'. The main area is a table with the following data:

Code	Description	OC	Alarm Date
E001	Water Temp. Over Heat	0	-
E002	Low Engine Oil Pressure	0	-
E003	Low Gearbox Oil Pressure	0	-
E004	Battery Charge(Alternator)	0	-
E005	Fuel Leakage(Switch)	0	-
E006	Over Speed	0	-
E007	Low Voltage	0	-
E008	Engine Oil Over Heat	0	-
E009	Main Connector Removed	0	-
E010	High Exhaust Gas Temperature	0	-
E011	Abnormal Engine Shutdown	0	-

At the bottom of the screen, it displays 'Low Engine Speed: 0'.

[Fig. 3-26] Fault Code List

Alarm List	
Water Temp. Over Heat	Low Voltage
Low Engine Oil Pressure	Engine Oil Over Heat
Low Gearbox Oil Pressure	Main Connector Removed
Battery Charge (Alternator)	High Exhaust Gas Temperature
Fuel Leakage (Switch)	Main Connector Removed
Over Speed	-

[Table. 3-11] Alarm List

# 3. Part Names, Operation and Settings

## 3.12 System Booting and Functional Check

---

- A checkup is conducted to ensure the proper installation of the product.

### ► Normal System Booting

- 1) After inserting the key into the key switch, if the key is rotated in the ON direction (right), it returns to the central point and is fixed.
- 2) HYUNDAI logo is displayed when the system is booted
  - ※ In case, the screen is not output when the key is rotated
    - Key OFF and then ON again
    - Check the harness connection behind the panel
    - Check for battery discharge
- 3) After booting normally, the gauge screen appears.
  - Gauge : Check that each gauge needle is within the normal range and check if it is displayed on the 'OPEN' or 'SHORT' screen
  - ※ When 'OPEN' or 'SHORT' occurs
    - Check the harness connection status
    - Function keys: Check whether each function key is operated normally
    - Warning light: Check if the warning light is on
    - Battery: Check if the battery voltage is normal
- 4) If there is no problem in the initial gauge screen, turn the key to start the engine.
- 5) Check RPM operation (initial 400RPM or higher, oil pressure 1bar or higher) and warning light on (red lamp blinks when warning light is on)

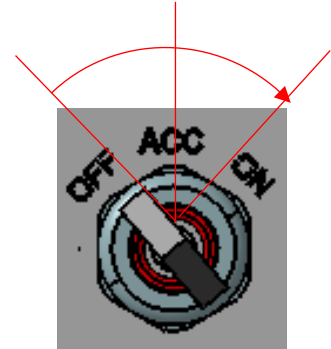

[Fig. 3-27] Key Switch

# 4. Multi Panel Structure

## 4.1 Multi Panel

- It is possible to install up to 3 additional units except for the Master in the vessel, and it is possible to check and control the vessel status at any time depending on the setting. (Be careful of the battery voltage drops as the length of the harness increases.)



# 4. Multi Panel Structure

## 4.2 How to Install Multi Panel

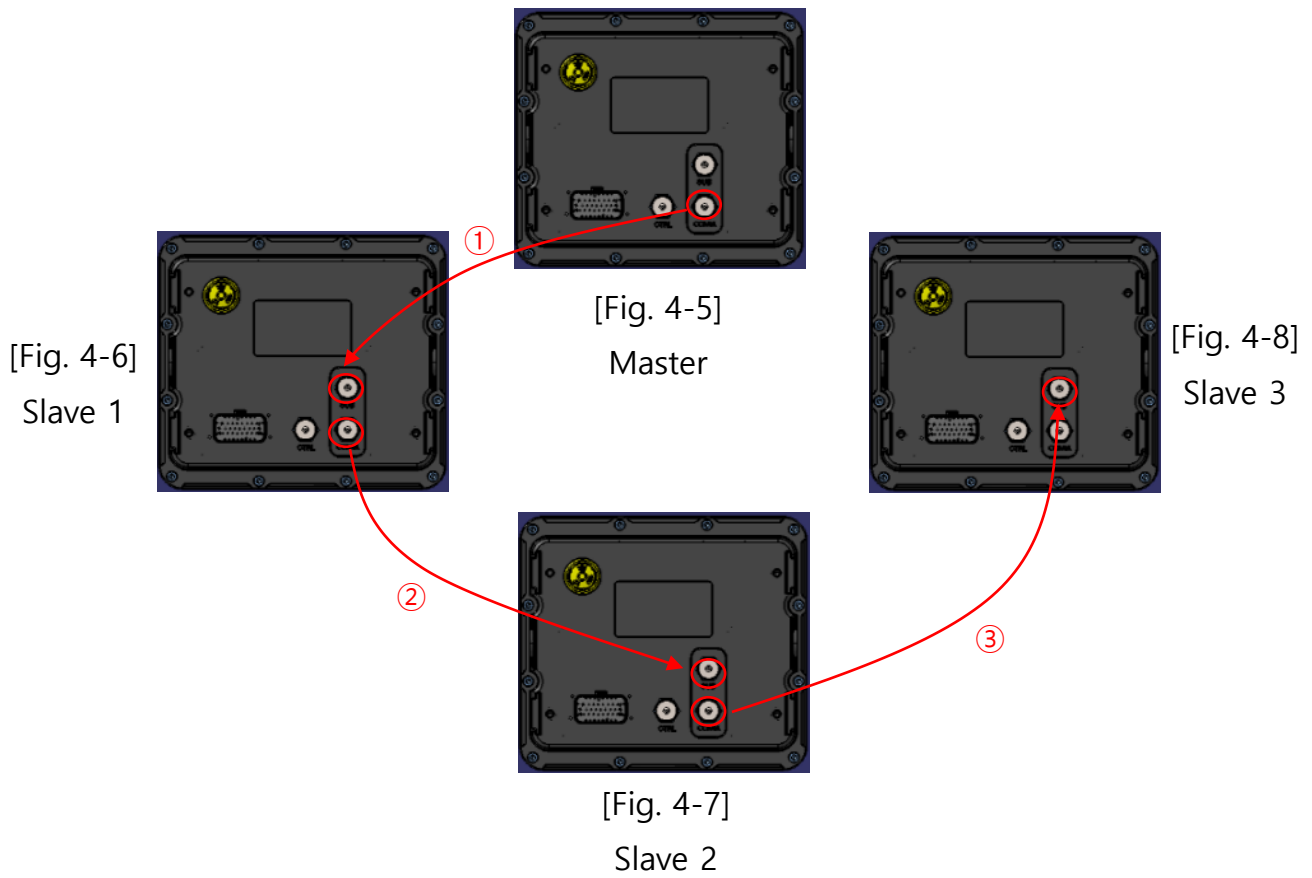

※ Before installing the multi-panel, the necessary cables should already be prepared.  
(Cables should use Hyundai's recommended specifications)

(1) Connect the SUB terminal of the Master panel to the main connector terminal of the Slave 1 panel as shown in ①. (2 panels)

● Master and Slave 1 connection completed

(2) In the state connected as in ① above, as in ②, that is, connect Slave1(COMM) to Slave2(SUB). (3 panels)

● Master and Slave 1, Slave 2 connection completed

(3) In the state connected as in ② above, as in ③, that is, connect Slave2(COMM) to Slave3(SUB). (4 panels)

● Master, Slave 1, Slave 2, Slave 3 connection completed

# 4. Multi Panel Structure

## 4.3 Multi Panel Setting

- (1) Press and hold the OK button of the panel to be set in Slave mode for 3 seconds.
- (2) When the Settings window opens, navigate to Figure ① (Use the directional keys to navigate).
- (3) Press the OK button to switch between Master / Slave1 / Slave2 / Slave3.
  - ※ Note: When connecting multiple Slaves, the Slave mode settings should not overlap.
- (4) Set the panel to Master mode using the same method as above

※ Note

- Only one product can be set in Master mode, and up to two Slaves are recommended.
- If the cable length between Master and Slaves is more than 30m, there may be a voltage drop of more than 1V, so it needs to be checked.
- Granting engine start permission to Slave panels can only be done from the Master panel and when the "slave engine start setting" is On, the selected slave panel has the starting authority.
- Emergency start is only possible from the Master panel, while emergency stop is possible from all panels.
  - The emergency stop of the Slave operates through CAN communication.
- During engine operation (RUN), re-engaging the starter is not possible.



[Fig. 4-9] Multi Panel Setting Popup

# 5. Maintenance

## 5.1 Maintenance

---

- To maintain the performance of the device, regular maintenance is required.
- 1. Use soft cloth to clean the LCD without damaging it.
  - 1) Clean the LCD after turning the power off.
  - 2) Do not use cleaners with acids or ammonia.
  - 3) Do not use neutral detergents to remove oil stains.
  - 4) Use cloth slightly wet in clean water to remove salt residuals or dust particles for natural drying. If there remain stains, clean them with soft cloth (microfibers) once again.
- 2. Check whether the connectors or harnesses at the back of the device are properly connected or whether they have dust or other foreign substances.
- 3. Check whether cables are damaged.
- 4. Request for checking when the software needs upgrade as follows:
  - When the manufacturer releases official software for performance improvements

## 5.2 Troubleshooting

---

- It describes possible measures for users to resolve problems while using the device.
- 1. The device is not turned on.
  - 1) Check whether harness cables at the back of the product are properly connected.
  - 2) Where harness cables have too much dust or moisture, remove them and clean the dust or moisture. Connect them once again after a while.
  - 3) Check whether the fuse button at the back of the product is pulled out.
  - 4) Check whether the battery is discharged.
- 2. You can see lines or shaking on the screen.
  - 1) Reboot the product.
  - 2) As the LCD is connected inside the product, do not disassemble it and contact the service team.
- 3. You can see alarm or hear warning beeps at the bottom of the product screen.
  - 1) Check where the alarm occurs and then take measures as necessary (if you need to confirm which alarm occurs, refer to Page 20 of this manual).
- 4. You cannot control buttons.
  - 1) Check whether there are foreign substances at the panel buttons.
  - 2) As the button connecting parts may be damaged, do not disassemble the product and contact the service team.

## 6. Warranty and A/S Service

### 6.1 Warranty

---

- As this manual contains important contents related to safety, use and maintenance of the product. So please read this manual carefully and then use the product in a proper manner.

Those who are not familiar with the product should keep this manual close to themselves.

- We are not responsible for human injuries or property damages caused by the following reasons:

- Where you use the product for purposes other than the ones described in this manual
- Where you alter the product or its components at discretion
- Where you disassemble the product at discretion to resolve problems
- Where you use accessories or parts not supplied or recommended by us
- ※ Where you use accessories or parts manufactured by other companies, please contact our service.

### 6.2 A/S Service Information

---

- When you request A/S service, please let us know the model's name, breakdown conditions and your contact information.
- Please ask the seller.

# 7. Appendix

## 7.1 List of Engine Models

- List of compatible engine models

- Engine		Gear 잇수	Rate Speed	Over Speed	
DB58TI	L066TIH	129	2,200	115%	2,530
D1146	L136	140	2,200	115%	2,530
D1146T	L136T	140	2,200	115%	2,530
	L136TL	140	2,500	115%	2,875
D1146TI	L136TI	140	2,200	115%	2,530
D1146TIB	L086TIH	140	2,200	115%	2,530
	L086TIM	140	2,300	115%	2,645
	L086TIL	140	2,500	115%	2,875
DE12T	MD196T	152	2,000	115%	2,300
DE12TI	MD196TI	152	2,000	115%	2,300
DE12TIB	L126TIH	152	2,000	115%	2,300
	L126TIM	152	2,100	115%	2,415
D2848LB	V158TIH	160	1,800	115%	2,070
	V158TIM	160	2,100	115%	2,415
	V158TIL	160	2,300	115%	2,645
D2840LB	V180TIH	160	1,800	115%	2,070
	V180TIM	160	2,100	115%	2,415
	V180TIL	160	2,300	115%	2,645
D2842LB	V222TIH	160	1,800	115%	2,070
	V222TIM	160	2,100	115%	2,415
	V222TIL	160	2,300	115%	2,645
4VD2848LB	4V158TIH	160	1,800	115%	2,070
	4V158TIM	160	2,100	115%	2,415
	4V158TIL	160	2,300	115%	2,645
4VD2842LB	4V222TIH	160	1,800	115%	2,070
	4V222TIM	160	2,100	115%	2,415
	4V222TIL	160	2,300	115%	2,645

# Digital Panel for Marine Generator's User Manual

Ver.1.2



# HYUNDAI

## ▶ Index

### 1. General Information

1.1	Product Information-----	4
1.2	Components-----	4
1.3	Product Specification-----	5

### 2. Product Installation

2.1	Cautions-----	6
2.2	Installation-----	6

### 3. Part Names, Operation and Settings

3.1	Front side-----	7
3.2	Rear side-----	7
3.3	External Connections-----	8
3.3.1	Power Connector-----	8
3.3.2	Signal Connector-----	9
3.3.3	CAN Connectors-----	10
3.3.4	External Buzzer Connector-----	10
3.3.5	DSC Connectors-----	10
3.3.6	USB Connector-----	11
3.4	Fuse & Buzzer-----	11
3.4.1	Fuse -----	11
3.4.2	Buzzer-----	11
3.5	Key Switch-----	11
3.6	Start/Stop Button-----	12
3.7	Emergency Stop Button-----	12
3.8	Function Keys-----	13
3.8.1	Setting Items-----	14
3.9	Display Structure-----	15

3.8.1	Engine Speed(Tachometer)-----	15
3.8.2	Engine Water Temperature-----	16
3.8.3	Engine Oil Pressure-----	16
3.8.4	Exhaust Gas Temperature-----	16
3.8.5	Battery Voltage-----	17
3.8.6	Sensor Check Lamp-----	17
3.8.7	Engine Alarm-----	17
3.8.8	DSC Alarm Display-----	18
3.8.9	Engine Stop-----	18
3.9	Spare Sensors-----	18
3.10	Event Summary-----	20
3.11	System Booting & Functional Check-----	21
<b>4.</b>	<b>Multi Panel Setup</b>	
4.1	Multi Panel-----	22
4.2	Multi Panel Installation-----	22
4.3	Multi Panel Setting-----	23
<b>5.</b>	<b>Maintenance</b>	
5.1	Maintenance-----	24
5.2	Troubleshooting-----	24
<b>6.</b>	<b>Warranty and A/S Service</b>	
6.1	Warranty-----	25
6.2	A/S Service Information -----	26
<b>7.</b>	<b>Appendix</b>	
7.1	List of Engine Models-----	27

# 1. General Information

## 1.1 Product Information

The name of the product model is DGP-2000 applicable to various marine generator engines. The product is intended to improve problems of existing analog panels and allow users to check engine controls and conditions by means of a digital visualization product. It provides information in analog graphic gauges and digital displays for enhanced user experiences.

## 1.2 Components

Items	Image	Qty	Description	Remark
DGP-2000 ASM		1	Body of Digital Panel for Marine Gen.	
DSC-2000		1	Digital Speed Controller for Marine & Cover	
DSC Bracket		1	Assembly DGP-2000 and DSC-2000	
Desk Mounting Type Bracket		1	To install DGP-2000	

Fix handle		2	Tilting DGP-2000
Key		2	To boot DGP-2000
Manual		1	User manual

[Table 1-1]

### 1.3 Product Specification

No.	Items	DGP-2000	DSC-2000
		Description	
1	CPU	• Cortex-A8, dsPIC33FJ256(16bit)	• dsPIC33FJ256(16bit)
2	S/W	• Windows CE 6.0 R2(OS)	• Firmware
3	Display	• 10.2" Color TFT LCD • 800 * 480(pixel) • 16 : 9	• Graphic LCD 128*64
4	Flash Memory	• 256MB(Flash) • 8GB(MicroSD card)	• 128MB
5	RAM	• 512MB	• -
6	Operating Volt.	• DC 24V (16 ~ 30V)	• DC 24V (12V~30V)
7	USB	• USB2.0 1Port	• -
8	Operating Temp.	• - 20°C ~ 70°C	• -20~+70°C
9	Buzzer	• Piezo Buzzer 98dB	• -
10	Communication	• J1939 CAN • RS232	• RS232 57600bps • CAN(J1939)/250kbps
11	Size	• W 344 x H 271 x D 160	• W 170 x H 165 x D 30

[Table 1-2]

## 2. Installation

### 2.1 Cautions

- Unskilled personnel should read this manual before use.
- Do not use or keep the product close to combustible sprays or inflammable.
- Use soft and dry cloth to clean the monitor.

Turn off the product, pull out the harness cable and then contact our service center when you see smoke from the monitor or have strange smells.

- When you see an alarm on, you always need to check the product before operation.
- Do not disassemble the product cover at discretion (warranty does not cover unauthorized disassembly).

- Excessive impact may damage the display although a reinforced display is used.
- Use connectors matching each other when connecting them to the back of the product.

Do not contact or remove connectors while the power is on. It may cause electric shock or lead to malfunction.

- Do not exercise excessive force when rotating to ON/OFF with the key inserted.
- Do not use the product with wet hands.
- Use protective caps for back side connectors that are not used.

### 2.2 Installation

- Install DGP-2000 in the engine room by using Desk Mounting brackets delivered with the product.



※ Spec. of mounting hole : M6 bolt

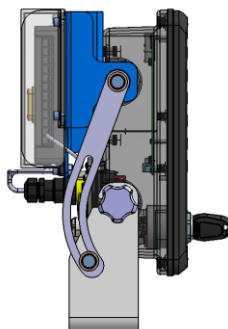

[Fig 2-1]

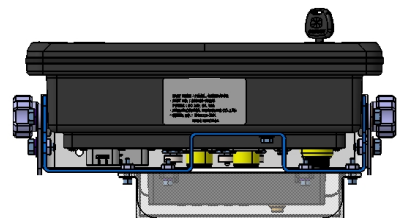

► Installation Sequence for DGP-2000

- 1) Check whether the engine room has engine harness wiring.
- 2) Separate the temporary assembled bracket from product.
- 3) Use the mounting hole to fix the bracket in a place within reach of the engine harness wiring.
- 4) Place the product inside the bracket connected with the rotation lock to connect it with the rotation lock.
- 5) Put the wave washer in the fix handle and connect it with the fix handle. Then adjust the viewing angle of the LCD.

※ Where there are things to which the product can be fixed, use spare holes with the bolt or other.

### 3. Part Names, Operation and Settings

#### 3.1 Front Side



[Fig 3-1]

No.	Name	Ref.
①	LCD	p15
②	Function Key	p13
③	Key Switch	p11
④	USB	p11
⑤	Buzzer	p11
⑥	Start/Stop Button	p12

[Table 3-1]

#### 3.2 Back Side

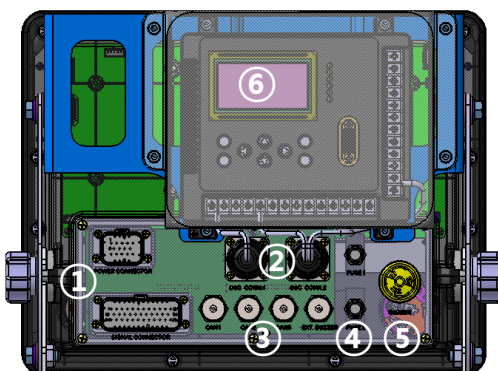

[Fig 3-2]

No.	Name	Ref.
①	Main Connector(2EA)	p8
②	DSC Connector(2EA)	p10
③	CAN & PC Communication	p10
④	Fuse(6A, 10A)	p11
⑤	Buzzer	p11
⑥	DSC	-

[Table 3-2]

### 3.3 External Connections

- External connection terminals are used for inputs and outputs of generator engine control signals and each sensor signals.

#### 3.3.1 Power Connector

- Power connector supplies power and power signals.



**POWER CONNECTOR**

[Fig 3-3]

No.	Pin Description	Remark
1	Alternator In	Battery
2	-	-
3	Battery(+)(DC 24V)	Input to fuse
4		
5	Starter Signal	-
6	-	-
7	-	-
8	Starter Signal	-
9	Starter Signal	-
10	Actuator A	-
11	Actuator B	-
12	GND	Power
13	GND	
14	Battery(+)(DC 24V)	Input to fuse

[Table 3-3]

### 3.3.2 Signal Connector

- Signal connector supplies sensor signals.

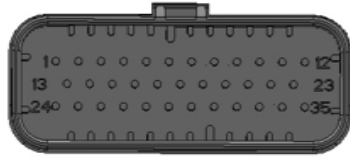

[Fig 3-4]

SIGNAL CONNECTOR

\* : Only for IMO Tier3

No.	Pin	Description	Remark	No.	Pin	Description	Remark
0		Exhaust Gas Temp. Sensor 1 (+)	-	19		Spare Analog Input 3	-
2		Engine Water Temp. Sensor	-	20		Pickup Sensor (+)	-
3		Engine Oil Pressure Sensor	-	21		-	-
4		*Engine Oil Temp. Sensor	-	22		-	-
5		*Boost Air Pressure Sensor	-	23		GND	Sensor
6		*Fuel Level Sensor	-	24		-	-
7		-	-	25		Exhaust Gas Temp. Sensor 2 (+)	-
8		Spare Analog Input 4	-	26		Exhaust Gas Temp. Sensor 2 (-)	-
9		Spare Digital Input 1	-	27		-	-
10		-	-	28		-	-
11		Fuel Leakage Switch	-	29		-	-
12		GND	Sensor	30		-	-
13		Exhaust Gas Temp. Sensor 1 (-)	-	31		-	-
14		Engine Water Press. Sensor	-	32		-	-
15		-	-	33		-	-
16		*Engine Water Level Sensor	-	34		-	-
17		*Boost Air Temperature Sensor	-	35		GND	Sensor
18		Spare Analog Input 1	-	-		-	-

[Table 3-4]

### 3.3.3 CAN Connectors

- CAN harness (optional) connection
- CAN1/CAN2: for multi panels
- CAN3: PC communication, firmware download



[Fig 3-5]

No.	CAN1	CAN2	CAN3
1	+12V Out	+12V Out	+12V Out
2	GND	GND	GND
3	CAN1_H	CAN1_H	CAN2_H
4	CAN1_L	CAN1_L	CAN2_L
5	Battery(+)	Battery(+)	PC_RXD1
6	GND	GND	PC_TXD1

[Table 3-5]

### 3.3.4 External Buzzer Connector

- Additional connection for external buzzer harness
- Generating external buzzer alarms for warnings



[Fig 3-6]

No.	Pin map
1	Battery(+) – Output of fuse
2	Alarm Out

[Table 3-6]

### 3.3.5 DSC Connector

- Connecting DGP-2000 with DSC-2000
- Function of DSC-2000 power supply, pick-up signal transmission, actuator signal transmission and CAN communication function



[Fig 3-7]

Pin No.	Pin Name	Description	Remark
A	Actuator A	Control signal for actuator	
B	Actuator B	Power for actuator	
C	-	-	

[Table 3-7]



[Fig 3-8]

Pin No.	Pin Name	Description	Remark
1	Batt. +	Power	DSC power on(off) by engine start(stop)
2	Batt. -	Power	
3	RPM	Pick-up signal	Original pickup signal through digital panel
4	CAN H	CAN High	DSC Inform., Idle/Run Switch
5	CAN L	CAN Low	
6-7	-	-	-

[Table 3-8]

### 3.3.6 USB Connector

- USB memory can be inserted for data backup.



USB  
[Fig 3-9]

## 3.4 Fuse and Buzzer

### 3.4.1 Fuse

- It consists of 6A(for digital panel) fuse and 10A(DSC-2000) fuse
- 10 seconds after fuse operation, press fuse button to recover

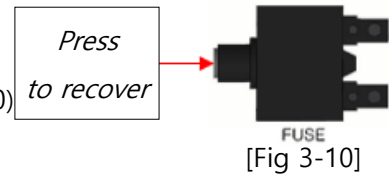

FUSE  
[Fig 3-10]

### 3.4.2 Buzzer

- Generate alarms for sensor problems



BUZZER  
[Fig 3-11]

## 3.5 Key Switch

- Key switch is used to boot and turn off the digital panel or stop the engine.

1) Use the key contained in the product to insert it and rotate to the right over 45° (ON) (when the key is ON, the key should remain inserted).

2) When the key is ON, the product will boot and the gauge display will

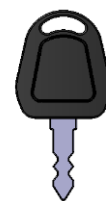

[Fig 3-12]

appear in about 15 seconds.

3) Rotate the key to the left by 45° (OFF) to turn it off.

- When rotating the key to the left (OFF) while the power is on, the display will show a popup message for 300 seconds. The engine will stop and the event will be saved after 300 seconds.
- When the popup window appears, rotate the key to the right (ON) to remove the window and keep the engine on.

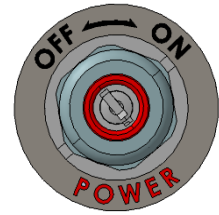

Key Switch  
[Fig 3-13]

### 3.6 Start/Stop Button

- Start/Stop button is used to start/stop control for the generator engine.
  - 1) Press the button for more than 1 second while the key is ON, the engine will start (the button LED will flash when pressing the button).
  - 2) Press the button for more than 1 second while the key is ON and the engine is in operation to stop the engine.
    - ※ The time can be set from 1 to 3 seconds. Ask for the service member.
    - ※ Installed the protection cover to prevent object come in.

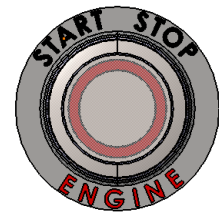

Start/Stop Button  
[Fig 3-14]

### 3.7 Emergency Stop Button

- Emergency Stop Button is used to urgent engine stop for the emergency situation.
  - 1) Press immediately when an emergency situation occurs in the engine run state.
    - Red LED on while pressing
  - 2) Release the button after the engine is completely stopped.
    - LED off when released
    - ※ If you release the button before stopping the engine, the engine will restart.



Emergency Stop  
Button  
[Fig. 3-15]

### 3.8 Function Keys

- Function keys are used to adjust LCD brightness, alarm mute, Idle/Run, Digit on/off, Home and other settings, move to and select menus, and reset the system.



[Fig 3-16]

No.	Function Key	Action Feature
①	LCD Brightness	- LCD brightness adjustable for 5 different levels (when rebooting the system, the previous setting will be maintained)
②	Alarm Mute	- Turn off the buzzer sound
③	Idle/Run	- Changing the engine status Idle to Run
④	Digit	- Digit is default on - Press <b>DIGIT</b> , the number light will be off - Press while the display is off, the number light will turn on
⑤	Home	- Move to main gauge display - Move to main display without saving when pressing it in page mode
⑥	Setting	- Engine Model setting - Master/Slave setting and ON/OFF setting to start the slave - ON/OFF oil supply mode - USB backup and date(year/month/hour) settings - Setting PID - Droop On/Off
⑦	Up/Down	- Move the cursor up and down in setting window
⑧	Enter	- Select menus or functions in the setting window
⑨	Page	- Move to spare sensor display (display page 2) / Move to event summary display (display page 3)
⑩	System Reboot	- Rebooting for system errors (press it for more than 3 seconds to reboot)

[Table 3-9]

### 3.8.1 Setting Items

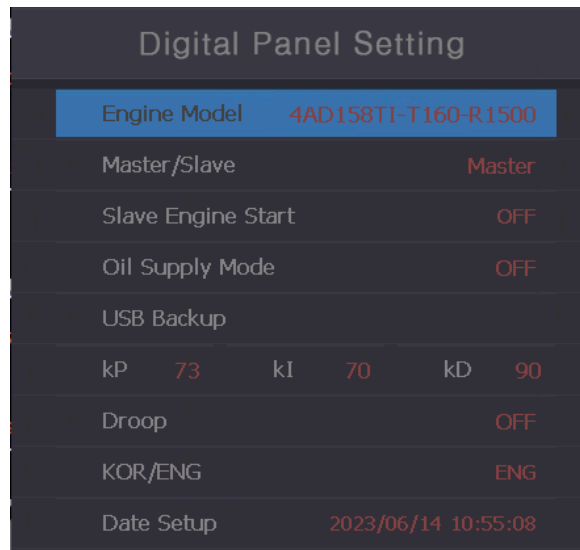

[Fig 3-17]

► Setting Functions and Descriptions

- Press **Setting** button and then use **Up** or **Down** button to move to functions to be changed.
- Press **Setting** button to go back to gauge display (changes will be automatically saved).

No.	Function	Description	Remark
1	Engine Model	Engine model setting (refer to the appendix for the list of engine models)	
2	Master / Slave	Master/Slave setting for multi panels	
3	Slave Engine Start	ON/OFF setting to start by slave	
4	Oil Supply Mode	Engine cranking	
5	USB Back Up	USB backup for the saved event files	
6	Droop	Setting the engine's droop mode	
7	PID	Changing PID values	
8	Date Setup	Date and time setting	

[Table 3-10]

### 3.9 Display Structure

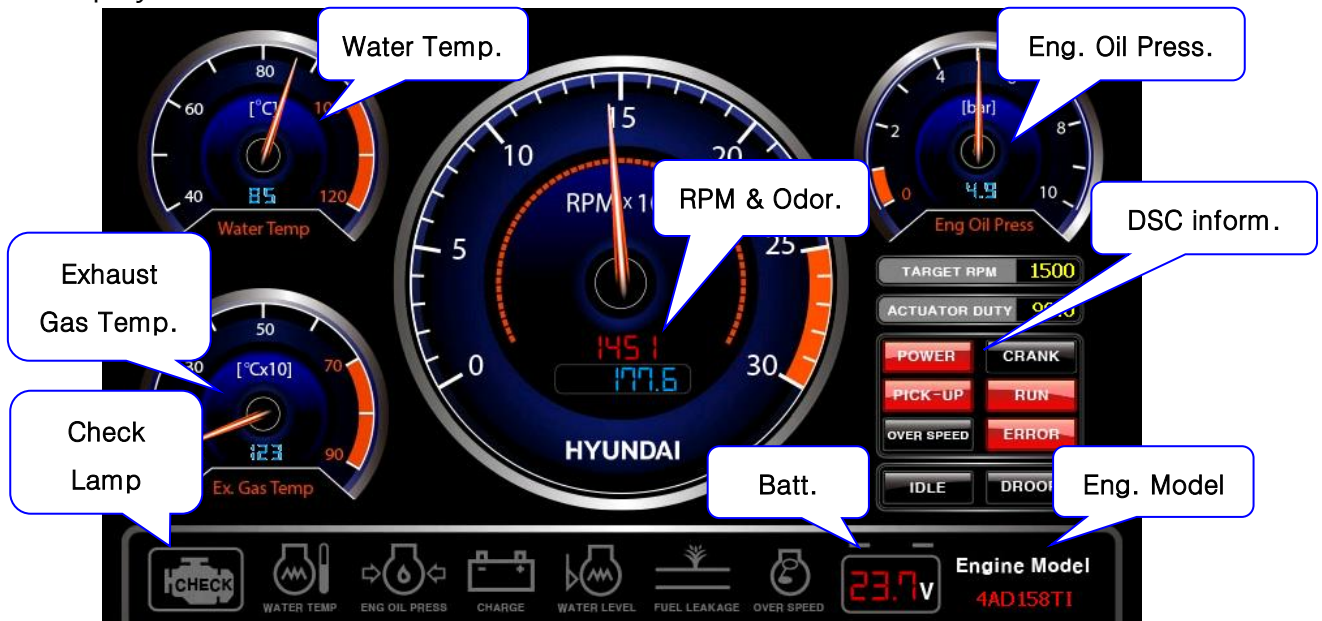

[Fig 3-18]

- Gauge display shows various gauge data including pick up(RPM) sensor, coolant temperature, exhaust gas temperature and engine oil pressure.
- DSC-2000 information icons to monitor the generator’s status.
- It also includes battery voltage indication, accumulated engine operation hours, coolant temperature, engine oil pressure, gearbox oil pressure, charging, coolant level, fuel leak and overspeed alarm.

#### 3.9.1 Engine Speed (Tachometer)

- It shows engine RPM in gauge and digital values and counts accumulated engine operation hours.
- Harness → Digital Panel → DSC → CAN → Digital Panel

- 1) It shows the RPM indicated by the gauge hand in digital values(red) for better accuracy.
- 2) It shows accumulated engine operation hours by hour unit. (engine speed of 400RPM or faster will be counted and the function is always on)
- 3) Starter Off RPM setting is available between 300 and 600RPM after the engine starts. (The service team can configure the setting in PC Manager)



[Fig 3-19]

- 4) Engine stop(DSC function) and alarm lamp, buzzer at 115% of rate speed

### 3.9.2 Engine Water Temperature

- It shows the coolant temperature in gauge and digital values.

1) It shows the temperature indicated by the gauge hand in digital values(blue) for better accuracy.

2) It shows the open/short diagnosis for sensor problems.

☞ Open: 'ERROR' / Short (GND): '-----'

3) It also serves as the water temperature switch.

4) It activates alarm and warning beep when the temperature increases up to 93°C or higher.

5) When the temperature increases up to 103°C or higher, the engine will stop.



[Fig 3-20]

### 3.9.3 Engine Oil Pressure

- It shows engine oil pressure in gauge and digital values.

1) It shows the pressure indicated by the gauge hand in digital values (blue) for better accuracy.

2) It shows the open/short diagnosis for sensor problems.

☞ Open: '-----' / Short (Power): 'ERROR'

3) It also serves as the engine oil pressure switch.

4) It activates alarm and warning beep when the pressure is 1bar or lower (detects in 10 seconds)

5) When the pressure is 0.5bar or lower, the engine will stop

6) It will not work before the engine starts.



[Fig 3-21]

### 3.9.4 Exhaust Gas Temperature

- It shows exhaust gas temperature in gauge and digital values.

1) It shows the temperature indicated by the gauge hand in digital values(blue) for better accuracy.

2) It shows the open/short diagnosis for sensor problems.

☞ Open: 'ERROR' / Short (GND): '-----'

3) It warning light turns on at 600 °C or higher (spare sensor page)



[Fig 3-22]

### 3.9.5 Battery Voltage

- It shows battery voltage to indicate its conditions.



1) It shows in blue for voltage of 24V or higher and red for voltage lower than 24V. [Fig 3-23]

2) It activates warning beep when the voltage is under 18V(regardless of whether the engine is in operation or not). ⚠ Possible battery degradation when over 28.9V (overcharge)

### 3.9.6 Engine Check Lamp

- When there are sensor errors (Open or Short), the check sensor lamp will flicker with buzzer.

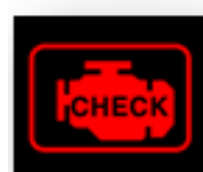

[Fig 3-24]

### 3.9.7 Engine Alarm Lamp

- The alarm lamp will flicker with buzzer beeping when problems for coolant temperature, engine oil pressure, charging, coolant level, fuel leakage and over speed are detected.

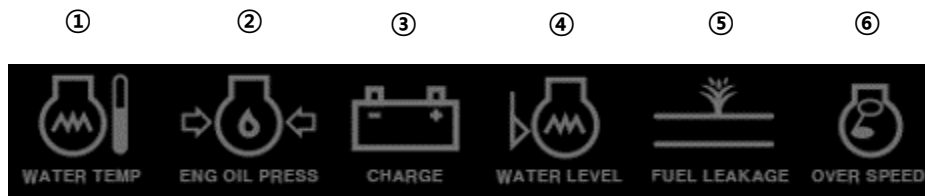

[Fig 3-25]

NO.	Lamp	Conditions
①	WATER TEMP(Coolant temperature)	• When the temp is <b>93°C</b> or higher
②	ENGINE OIL PRESS(Engine oil pressure)	• When the pressure is <b>1 bar</b> or lower
③	CHARGE(Battery Charge)	• When the battery voltage is lower than 18V
④	WATER LEVEL(Coolant level)	• When the level is <b>30%</b> or lower(Default 'disable')
⑤	FUEL LEAKAGE(Fuel leakage)	• When oil leak occurs(Default 'disable')
⑥	OVER SPEED(Engine over speed)	• When the speed exceeds <b>115%</b> of the rate speed

[Table 3-11]

※ How to deactivate the engine alarm

- Press SYSTEM RESET button on the right for 3 seconds, the system will reboot and the alarm will be deactivated(rebooting is available while the ship navigates without causing problems).

### 3.9.8 DSC-2000 information icons



[Fig 3-26]

No.	Description
①	Target RPM for generator
②	Duty rate of the current actuator for generator
③	Indication for Power on/off status of DSC-2000
④	Indication for PICK-UP signal input status
⑤	Indication for generator OVER SPEED
⑥	Indication for generator CRANK status
⑦	Indication for generator RUN status
⑧	Indication for generator ERROR status
⑨	Indication for generator IDLE ON/OFF status
⑩	Indication for generator DROOP ON/OFF status

[Table 3-12]

### 3.9.9 Engine Stop

- When the over speed exceeds **115%** of the rate speed → **Function of DSC-2000**
- When the coolant temperature exceeds **103°C** → Enable/Disable engine stop
- When the oil pressure is lower than **0.5bar** → Enable/Disable engine stop
- When fuel leakage occurs → Enable/Disable engine stop
- When the coolant level is **15%** or lower → Enable/Disable engine stop
- When 300 seconds alarm message pop up due to key off during engine run
- When the stop button will be activated by users(Digital Speed Controller power off)

### 3.10 Spare Sensors

- It identifies the status of spare sensors, product S/N, S/W version and date. Press **Page** button of the function keys to move to spare sensor page.

RPM	Eng Oil Press	Eng Oil Temp.	Water Temp.	Ex. Gas Temp.
1451	4.98 bar	120.0 °C	85.5 °C	123 °C
Boost Air Temperature		50.2 °C		
Boost Air Pressure(Low)		0.49 bar ●		
Boost Air Pressure(High)		0.49 bar ●		
Engine Oil Over Heat		120.0 °C		
Battery Voltage		23.8 V		
Exhaust Air Temperature(High)		123 °C ●		
Water Level(Low)		100 % ●		
Fuel Level(Low)		50 % ●		
<small>S/N 220903-001 GUI V2.5-200310 F/W V2.00 (Build:2022/05/01, Map:2023/01/12)                      DSC V1.60 (F/W:2021/08/28) 2023/06/14 11:05:24</small>				

[Fig 3-27]

Items	Conditions
*Boost Air Temperature	• Current temperature of BATS(No alarm)
*Boost Air Pressure	• Normal when the pressure is between 1.1 and 2.9bar
*Boost Air Pressure (Low)	• Alarm when the pressure is lower than 1bar
*Boost Air Pressure (High)	• Alarm when the pressure is higher than 3bar
*Engine Oil Over Heat	• Alarm when the temperature is higher than 120°C
Battery Voltage	• Current battery voltage
Exhaust Air Temperature(High)	• Alarm when the temperature is higher than 600°C
*Water Level (Low)	• Alarm when the coolant level is lower than 30%
*Fuel Level (Low)	• Alarm when the fuel level is lower than 30%

\* : Sensor for IMO Tier3

[Table 3-13]

### 3.11 Event Summary

- It shows the numbers of normal operations, normal stops, emergency stops and sensor errors together with dates of recent errors.
- Press **Page** button in spare sensor page to move to event summary page.

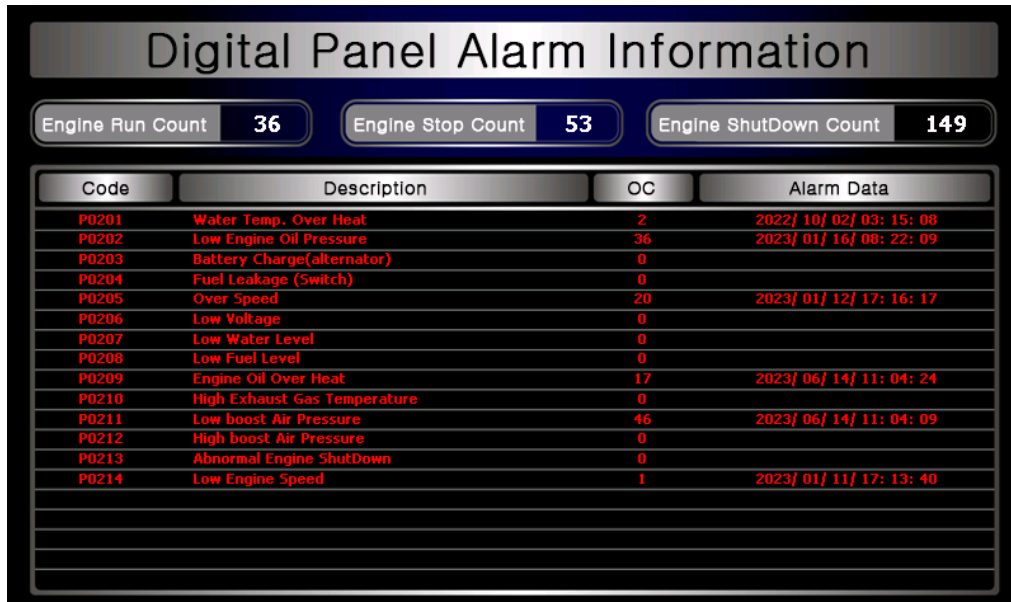

[Fig 3-28]

Event List			
P0201	Water Temp. Over Heat	P0208	*Low Fuel Level
P0202	Low Engine Oil Pressure	P0209	Engine Oil Over Heat
P0203	Battery Charge(Alternator)	P0210	High Exhaust Gas Temperature
P0204	Fuel Leakage(Switch)	P0211	*Low Boost Air Pressure
P0205	Over Speed	P0212	*High Boost Air Pressure
P0206	Low Voltage	P0213	Abnormal Engine Shutdown
P0207	*Low Water Level	P0214	Low engine Speed

\* : Sensor for IMO Tier3

[Table 3-14]

### 3.12 System Booting and Functional Check

- You can check whether the product is properly installed or not.

#### ▶ Normal System Booting

- 1) Insert the key into the key switch and rotate it to the right (ON).
- 2) HYUNDAI logo will appear for 17 seconds while the system is booting (refer to the image).

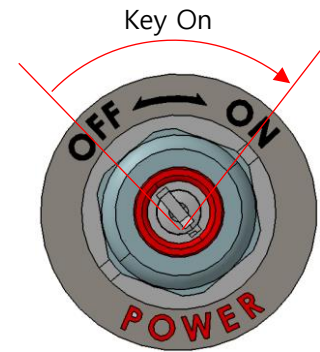

[Fig 3-29]

- ※ If the logo does not appear after rotating the key,
  - Rotate it to the left (OFF) and then to the right (ON) again
  - Check the harness connection at the back of the panel
  - Check whether the battery is discharged

- 3) The gauge display will appear after normal booting.

- Gauge: check whether each gauge hand is within the normal range and 'ERROR' or '-----' is displayed on the screen
  - ※ Where 'ERROR' or '-----' is displayed on the screen
- Check the harness connection
- Function keys : check whether each function key is active on the screen by pressing them
- Alarm : check whether the alarm is turned on
- Battery : check whether the battery voltage is 18V or lower

- 4) Where the initial gauge screen is normal, press START button for 1 second to start the engine (the time can be set from 1 to 3 seconds by the service team)

- 5) Check whether the operation is in normal RPM (initial operation in 400RPM or faster with the oil pressure of 1bar or higher) and whether alarm is turned on.



[Fig 3-30]

## 4. Multi Panel Structure

### 4.1 Multi Panel

- Panels can be installed up to 4 units except Master in the ship and you can check the ship conditions and control those panels at any places of installation.



### 4.2 How to Install Multi Panel

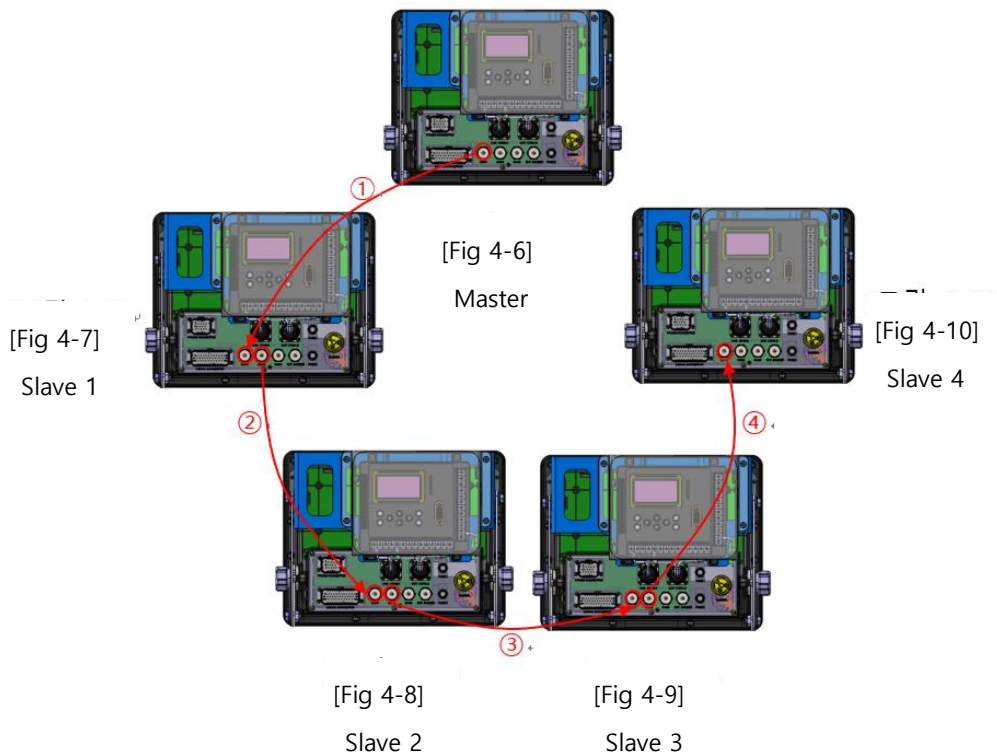

※ In order to install multi panels, all the necessary cables should be ready in advance(use the cables with specification recommended by HYUNDAI).

1) Connect the CAN1 terminal of the Master panel and the CAN1 terminal of the Slave 1 panel as shown in ① (2 panels).

●Master and Slave 1 connection completed

2) Connect Slave 1 (CAN2) and Slave 2 (CAN1) as shown in ② while maintaining connection as described in ① (3 panels).

●Master, Slave 1 and Slave 2 connection completed

3) Connect Slave 2 (CAN2) and Slave 3 (CAN1) as shown in ③ while maintaining connection as described in ② (4 panels).

●Master, Slave 1, Slave 2 and Slave 3 connection completed

4) Connect Slave 3 (CAN2) and Slave 4 (CAN1) as shown in ④ while maintaining connection as described in ③ (5 panels).

●Master, Slave 1, Slave 2, Slave 3 and Slave 4 connection completed

### 4.3 Multi Panel Settings

1) Press **Setting** button of the panel to be configured as Slave.

2) Move to ① when the setting screen appears (click **Up** or **Down** button to move).

3) Press **Enter** button to switch configuration between Master and Slave..

4) Configure the Master panel as described above.

※ Notes

●Master mode is available for one panel only and Slave mode is available up to 4 units.

●You can permit Slaves to start the engine with Master panel only. Where you enable Slave Engine Start setting, all Slave panels will be able to start the engine.

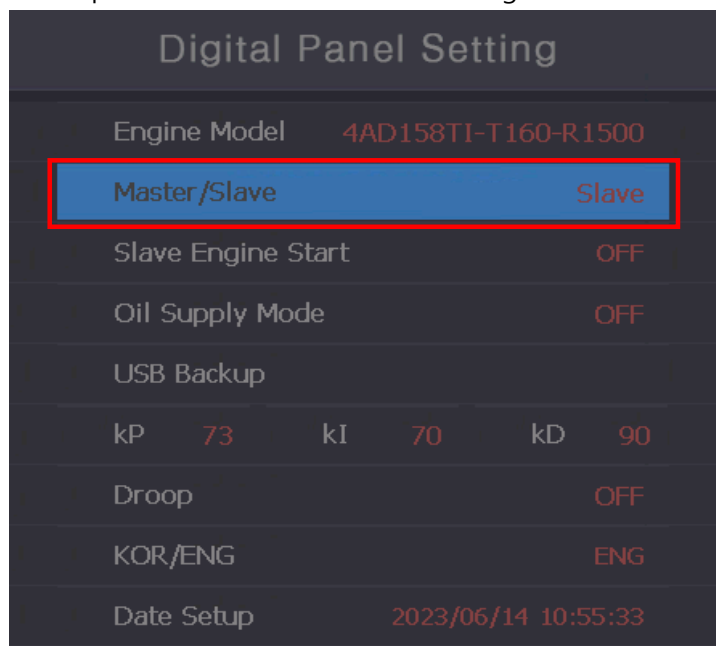

[Fig 4-11]

## 5. Maintenance

### 5.1 Maintenance

- To maintain the performance of the device, regular maintenance is required.
- 1. Use soft cloth to clean the LCD without damaging it.
  - 1) Clean the LCD after turning the power off.
  - 2) Do not use cleaners with acids or ammonia.
  - 3) Do not use neutral detergents to remove oil stains.
  - 4) Use cloth slightly wet in clean water to remove salt residuals or dust particles for natural drying.  
If there remain stains, clean them with soft cloth (microfibers) once again.
- 2. Check whether the connectors or harnesses at the back of the device are properly connected or whether they have dust or other foreign substances.
- 3. Check whether cables are damaged.
- 4. Request for checking when the software needs upgrade as follows:
  - When the manufacturer releases official software for performance improvements
- 5. Don't give a large shock to the product.

### 5.2 Troubleshooting

- It describes possible measures for users to resolve problems while using the device.
- 1. The device is not turned on.
  - 1) Check whether harness cables at the back of the product are properly connected.
  - 2) Where harness cables have too much dust or moisture, remove them and clean the dust or moisture. Connect them once again after a while.
  - 3) Check whether the fuse button at the back of the product is pulled out.
  - 4) Check whether the battery is discharged.
- 2. You can see lines or shaking on the screen.
  - 1) Reboot the product.
  - 2) As the LCD is connected inside the product, do not disassemble it and contact the service team.
- 3. You can see alarm or hear warning beeps at the bottom of the product screen.
  - 1) Check where the alarm occurs and then take measures as necessary (if you need to confirm which alarm occurs, refer to Page 20 of this manual).
- 4. You cannot control buttons.
  - 1) Check whether there are foreign substances at the panel buttons.
  - 2) As the button connecting parts may be damaged, do not disassemble the product and contact the service team.

## 6. Warranty and A/S Service

### 6.1 Warranty

- As this manual contains important contents related to safety, use and maintenance of the product. So please read this manual carefully and then use the product in a proper manner. Those who are not familiar with the product should keep this manual close to it.

We are not responsible for human injuries or property damages caused by the following reasons:

- Where you use the product for purposes other than the ones described in this manual
- Where you alter the product or its components at discretion
- Where you disassemble the product at discretion to resolve problems
- Where you use accessories or parts not supplied or recommended by us
- ※ Where you use accessories or parts manufactured by other companies, please contact our service center to check their compatibility.

## 6.2 A/S Service Information

- When you request A/S service, please let us know the model name, breakdown conditions and your contact information.
- Please ask the seller.

## 7. Appendix

### 7.1 Generator Engine List

Engine Name	Product Name	RPM	Tooth	
DB58TI	AD066TI	1500	129	
		1800		
D1146	AD136	1500	140	
		1800		
D1146T	AD136T	1500		
		1800		
D1146TI	AD136TI	1500		
		1800		
D1146TIB	AD086TI	1500		
		1800		
DE12TI	AD196TI	1500		152
		1800		
DE12TIB	AD126TI	1500		
		1800		
DX12	4AD126TIF	1500	106	
	4AD126TIS	1800		
D2848LB	AD158TI	1500		
		1800		
D2840LB	AD180TI	1500		
		1800		
D2842LB	AD222TI	1500		160
		1800		
4VD2848LB	4AD158TI	1500		
		1800		
4VD2842LB	4AD222TI	1500		
		1800		

[Table 7-1]