

Operation & Maintenance Manual

MARINE ENGINE

4L126C, 4AD126C, 4P126C



WARNING: Breathing diesel engine exhaust exposes you to chemicals known to the State of California to cause cancer and birth defects or other reproductive harm.

- Always start and operate the engine in a well-ventilated area.
- If in an enclosed area, vent the exhaust to the outside.
- Do not modify or tamper with the exhaust system.
- Do not idle the engine except as necessary.

For more information go to www.P65Warnings.ca.gov.



WARNING: This product can expose you to chemicals including lead, which is known to the State of California to cause cancer and birth defects or other reproductive harm.















For more information go to www.P65Warnings.ca.gov.

Preface

This manual includes the operation and maintenance information for DX12 marine engines. The first part contains information about operating the engine, while the second part contains information about engine maintenance, disassembling parts, inspections, repairs and reassembly, etc. The information was organized to enhance understanding of related parts and to make it easier to decide on maintenance procedures and repair parts.

The maintenance symbols included in this manual are as follows.

Be sure to observe the following to protect the environment when servicing the engine.

	Remove		Adjust
	Install		Clean
	Disassemble		Requires careful attention - Important
	Reassemble		Tighten to specified torque
	Align marks		Use special tool from manufacturer
	Direction mark		Lubricate with oil
	Inspect		Lubricate with grease
	Measure		

While servicing the engine, be sure to comply with the following instructions in order to prevent environmental damage.

- Take used oil to a used oil recycling facility.
- Never allow oil or diesel fuel to enter the sea, streams, waterways or the ground.
- Dispose of undiluted anticorrosives, antifreeze, filter elements and cartridges as special waste.
- Used coolant and special waste must be disposed of in compliance with the regulations of local institutions.

Some of the pictures in this manual use examples from a representative model for explanations. There may be slight differences with the actual shape of each individual model. Please contact the Marine Division of HD Hyundai Infracore (Inc.) if you have any inquiries or suggestions for improvement regarding the contents of this manual.

Finally, the contents of this operation and maintenance manual may be subject to change without notice in order to improve quality. Thank you.

* Items exempted from warranty coverage

- Malfunctions resulting from failing to comply with the proper handling instructions, regular inspections, and machine storage techniques specified in the user manual
- Malfunctions resulting from failing to have the machine repaired at a designated dealer or center, or resulting from the use of non-genuine parts
- Malfunctions resulting from unauthorized modifications, changes, or external hardware
- Malfunctions resulting from incorrect operation by the user, delayed repairs, accidents, and natural disasters

* The contents of this operation and maintenance manual are the exclusive property of HD Hyundai Infracore. Any unauthorized reproduction, printing and distribution thereof are strictly prohibited.

Table of Contents

1. General Information

1.1. Engine Specifications	1
1.2. Schematic Diagram of Engine	3
1.3. Engine Performance Curve	5
1.4. Engine Model and Serial Number	19

2. Safety Regulations

2.1. General Information	21
2.2. Rules for Preventing Injuries	21
2.3. Preventing Engine Damage and Premature Wear	23
2.4. Rules for Preventing Environmental Pollution	23
2.5. Safety Matters for Handling Used Engine Oil	24
2.6. Cause of Electrolytic Corrosion	24

3. Operation

3.1. Inspection Items Before Running the Engine	25
3.2. Starting	28
3.3. Operation	28
3.4. Inspection After Starting the Engine	29
3.5. Inspection After 50-Hour Break-In	30
3.6. Running the Engine in Winter	30
3.7. Servicing and Checking Engine Parts After Prolonged Operation	31

4. General Inspections

4.1. Precautions for General Inspections	33
4.2. Daily and Regular Inspections	34
4.3. Cooling System	35
4.4. Lubrication System	42
4.5. Intake and Exhaust System	46
4.6. Fuel System	48
4.7. Electrical System	55
4.8. Long-Term Engine Storage and Maintenance	55
4.9. Measures to Take if the Engine is Submerged in Water	56

5. Main Components

5.1. Reduction Gear	57
5.2. Front of Engine Power Takeoff (F.P.T.O.)	59
5.3. Propeller	60

6. Engine Service

6.1. Disassembly	61
6.2. Checking the Main Components	77
6.3. Engine Reassembly	93
6.4. Test Operation After Maintenance	119

7. Maintenance of Main Components

7.1. Lubrication System	121
7.2. Cooling System	122
7.3. Fuel System	123

8. Electrical System

8.1. Circuit Diagram	127
8.2. Switches and Sensors	138
8.3. Engine Control Unit (ECU)	143
8.4. TMS 3.0 (Option)	146
8.5. Starter Motor	150
8.6. Alternator	151
8.7. Fault Code List	152

9. Aftertreatment System (IMO Tier3/Stage-V)

9.1. Exhaust Gas Reduction System	159
---	-----

1. General Information

1.1. Engine Specifications

Specifications	Model	Unit	4L126C (Propulsion Engine)			
			Continuous Duty		Heavy Duty	
			4L126CASC 4L126CAKC	4L126CASH-II 4L126CAKH-II 4L126CARH	4L126CASH 4L126CAKH 4P126CASH	4L126CBSH 4L126CBKH 4L126CBVH
Engine type		4-stroke, in-line, common rail, water-cooled turbocharger, intercooler				
Rated power (B.H.P)	kW (PS) / rpm	331 (450) / 1,800	405 (550) / 2,100	368 (500) / 2,000	294 (400) / 2,000	
Displacement	cc	11,051				
Number of cylinders - bore x stroke	mm	6 - Ø123 x 155				
Flywheel & housing		FWH : SAE#1 / FW : 14"				
Min. idle rpm	rpm	600	600	600	600	
No-load maximum rpm	rpm	1,900	2,200	2,100	2,100	
Compression ratio		15.5 : 1				
Firing order		1-5-3-6-2-4				
Fuel consumption (IMO-T2)	g/PS.h	147	158	155	152	
	liter/h	80	105	94	74	
Fuel consumption (IMO-T3)	g/PS.h	149	160	157	154	
	liter/h	81	106	95	75	
Fuel consumption (EPA-T3)	g/PS.h	157	160	163	160	
	liter/h	85	106	98	77	
Starting method		Electric starting with starter motor				
Starter motor capacity	V-kW	24-7.0				
Alternator capacity	V-A	24-80				
Battery	V-Ah	24-200				
Cooling method		Indirect saltwater cooling by heat exchanger				
Coolant Capacity	Liter	Max. : 42, min. : 39				
Fresh water pump type		Centrifugal (pulley type)				
Saltwater pump type		Rubber impeller type				
Engine oil	Fan capacity	Liter	Max. : 44, min. : 20 (whole engine : 47)			
	Pressure	kg/cm ²	Full load : 3.0, idle : 1.0			
Direction of rotation	Crank-shaft		Counterclockwise when seen from the stern			
Engine dimensions (excluding reduction gear) (L x W x H)	mm	1,607 x 894 x 1,287 (Based on the propulsion engine)				
Engine weight (excluding reduction gear)	kg	1,182 (Based on the propulsion engine)				
Type of high-pressure fuel pump		Bosch CP3.4H+ (common rail system)				
Engine control type		ECU				
Fuel injection starting pressure	bar	1,800				
Injector nozzle type		Multi-hole type				
Fuel filter type		Cartridge				

Specifications	Model	Unit	4AD126C (Auxiliary Engine)		
			50 Hz (1,500 rpm)	60 Hz (1,800 rpm)	
			4AD126CASF 4AD126CAKF 4AD126CAVF	4AD126CASS 4AD126CAKS	4AD126CBSS 4AD126CBKS 4AD126CAVS
Engine type		4-stroke, in-line, common rail, water-cooled turbocharger, intercooler			
Rated power (B.H.P)	kW (PS) / rpm	287 (390) / 1,500	335 (455) / 1,800	280 (381) / 1,800	
Displacement	cc	11,051			
Number of cylinders - bore x stroke	mm	6 - Ø123 x 155			
Flywheel & housing		FWH : SAE#1 / FW : 14"			
Min. idle rpm	rpm	600	600	600	
No-load maximum rpm	rpm	1,500	1,800	1,800	
Compression ratio		15.5 : 1			
Firing order		1-5-3-6-2-4			
Fuel consumption (IMO-T2)	g/PS.h	148	149	149	
	liter/h	70	82	69	
Fuel consumption (IMO-T3)	g/PS.h	149	151	151	
	liter/h	71	83	70	
Fuel consumption (EPA-T3)	g/PS.h	-	158	157	
	liter/h	-	87	72	
Starting method		Electric starting with starter motor			
Starter motor capacity	V-kW	24-7.0			
Alternator capacity	V-A	24-80			
Battery	V-Ah	24-200			
Cooling method		Indirect saltwater cooling by heat exchanger			
Coolant Capacity	Liter	Max. : 42, min. : 39			
Fresh water pump type		Centrifugal (pulley type)			
Saltwater pump type		Rubber impeller type			
Engine oil	Fan capacity	Liter	Max. : 44, min. : 20 (whole engine : 47)		
	Pressure	kg/cm ²	Full load : 3.0, idle : 1.0		
Direction of rotation	Crank-shaft		Counterclockwise when seen from the stern		
Engine dimensions (excluding reduction gear) (L x W x H)	mm	1,607 x 894 x 1,287 (Based on the propulsion engine)			
Engine weight (excluding reduction gear)	kg	1,182 (Based on the propulsion engine)			
Type of high-pressure fuel pump		Bosch CP3.4H+ (common rail system)			
Engine control type		ECU			
Fuel injection starting pressure	bar	1,800			
Injector nozzle type		Multi-hole type			
Fuel filter type		Cartridge			

1.2. Schematic Diagram of Engine

Note: The images shown represent the standard model; they do not include all models.

1.2.1. Outside Drawing of the Engine

- Flatness

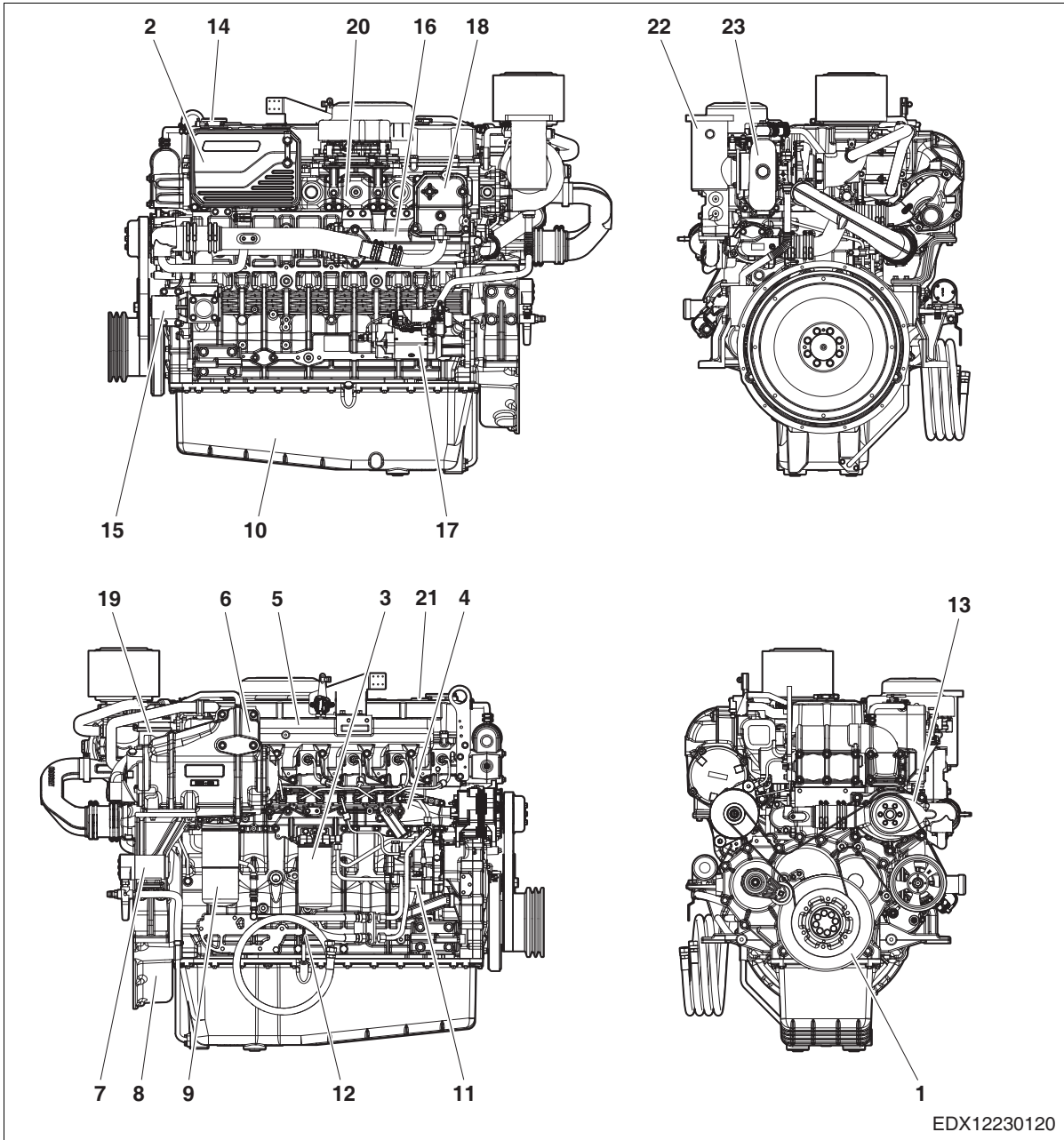

EDX12230120

- | | | |
|----------------------|-------------------------|----------------------------|
| 1. Crankshaft pulley | 9. Oil filter | 17. Starter motor |
| 2. Reservoir tank | 10. Oil pan | 18. Thermostat |
| 3. Fuel Filter | 11. Fuel injection pump | 19. Breather |
| 4. Oil cooler | 12. Oil measuring gauge | 20. Exhaust manifold |
| 5. Intake manifold | 13. Fresh water pump | 21. Oil filler cap |
| 6. Intercooler | 14. Coolant filler cap | 22. Exhaust discharge pipe |
| 7. Oil drain pump | 15. Saltwater pump | 23. Turbocharger |
| 8. Flywheel housing | 16. Heat exchanger | |

● Structural Diagram

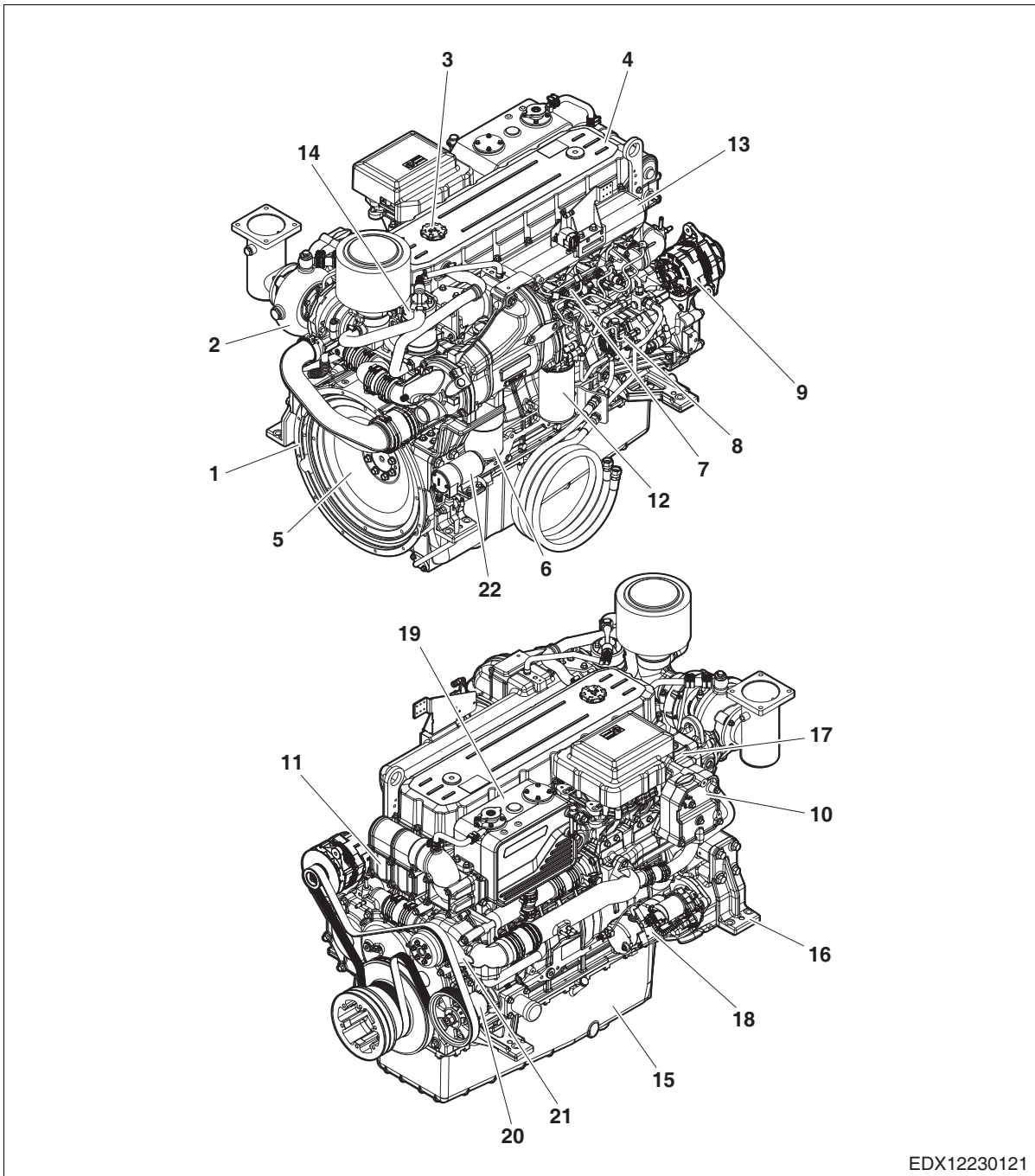

EDX12230121

- | | | |
|------------------------|----------------------|----------------------|
| 1. Flywheel housing | 9. Alternator | 17. Exhaust manifold |
| 2. Turbocharger | 10. Thermostat | 18. Starter motor |
| 3. Oil filler cap | 11. Water chamber | 19. Reservoir tank |
| 4. Cylinder head cover | 12. Fuel Filter | 20. Saltwater pump |
| 5. Flywheel | 13. Intake manifold | 21. Fresh water pump |
| 6. Oil filter | 14. Breather filter | 22. Oil drain pump |
| 7. Oil cooler | 15. Oil pan | |
| 8. Injection pump | 16. Mounting bracket | |

1.3. Engine Performance Curve

1.3.1. Performance Curve (IMO Tier2)

● 4L126CASH-II (Heavy Duty)

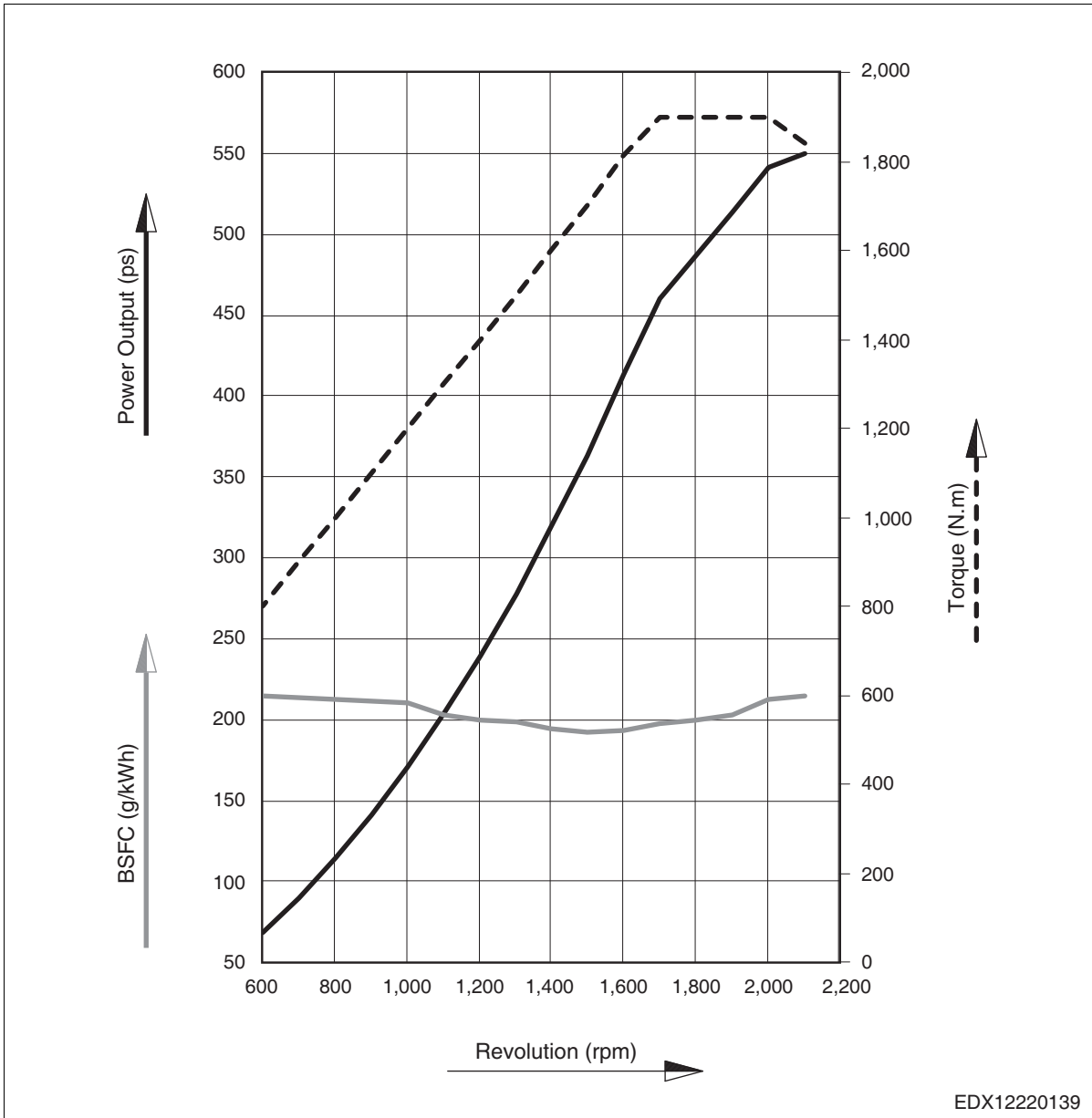

Testing and evaluation method		KS - R0071
Engine power	(max.)	550 PS (405 kW) / 2,100 rpm
Fuel consumption	(rated)	215 g/kWh

● 4L126CASH (Heavy Duty)/4P126CASH (Power Unit)

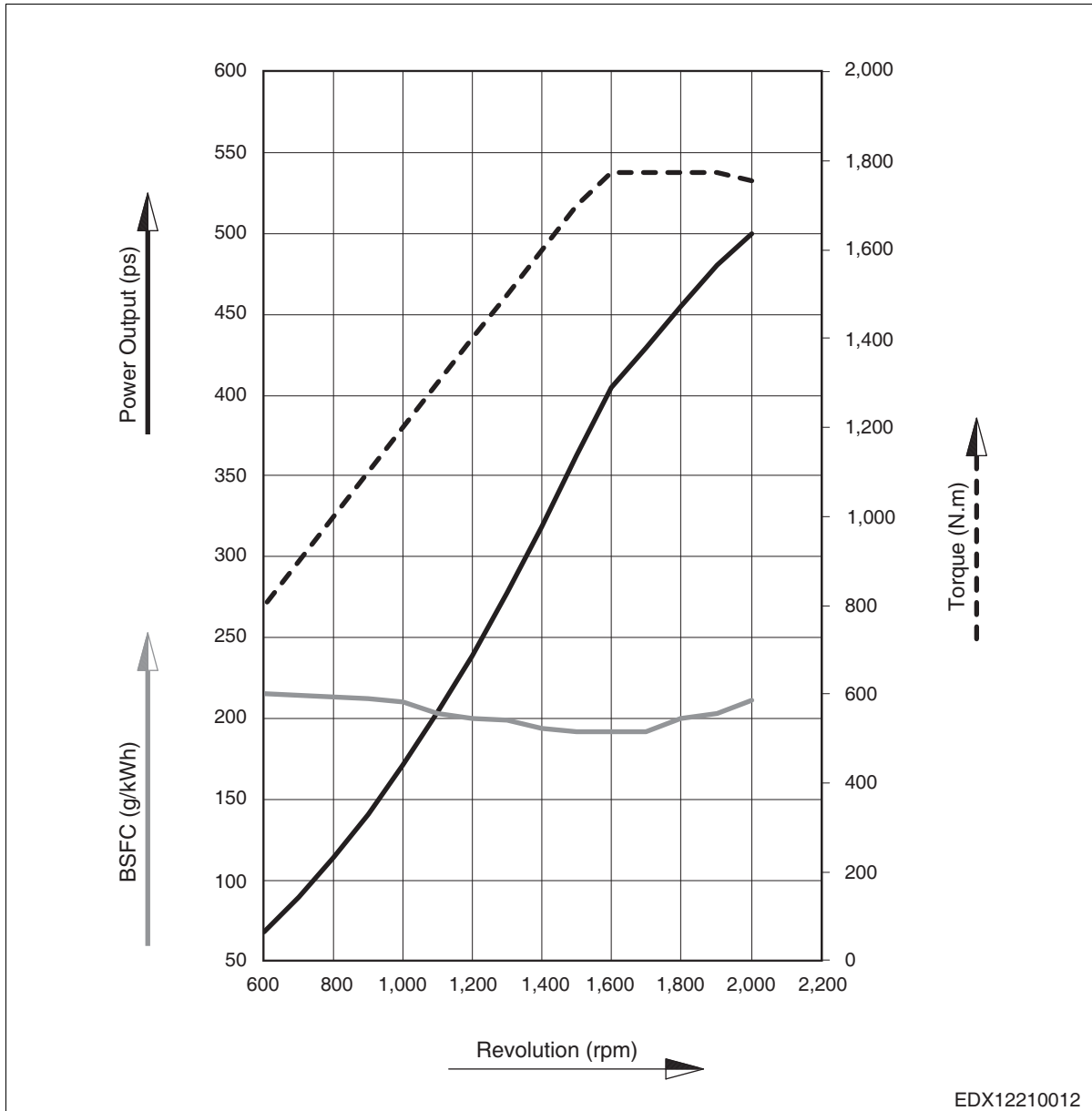

Testing and evaluation method		KS - R0071
Engine power	(max.)	500 PS (368 kW) / 2,000 rpm
Fuel consumption	(rated)	211 g/kWh

● 4L126CBSH (Heavy Duty)

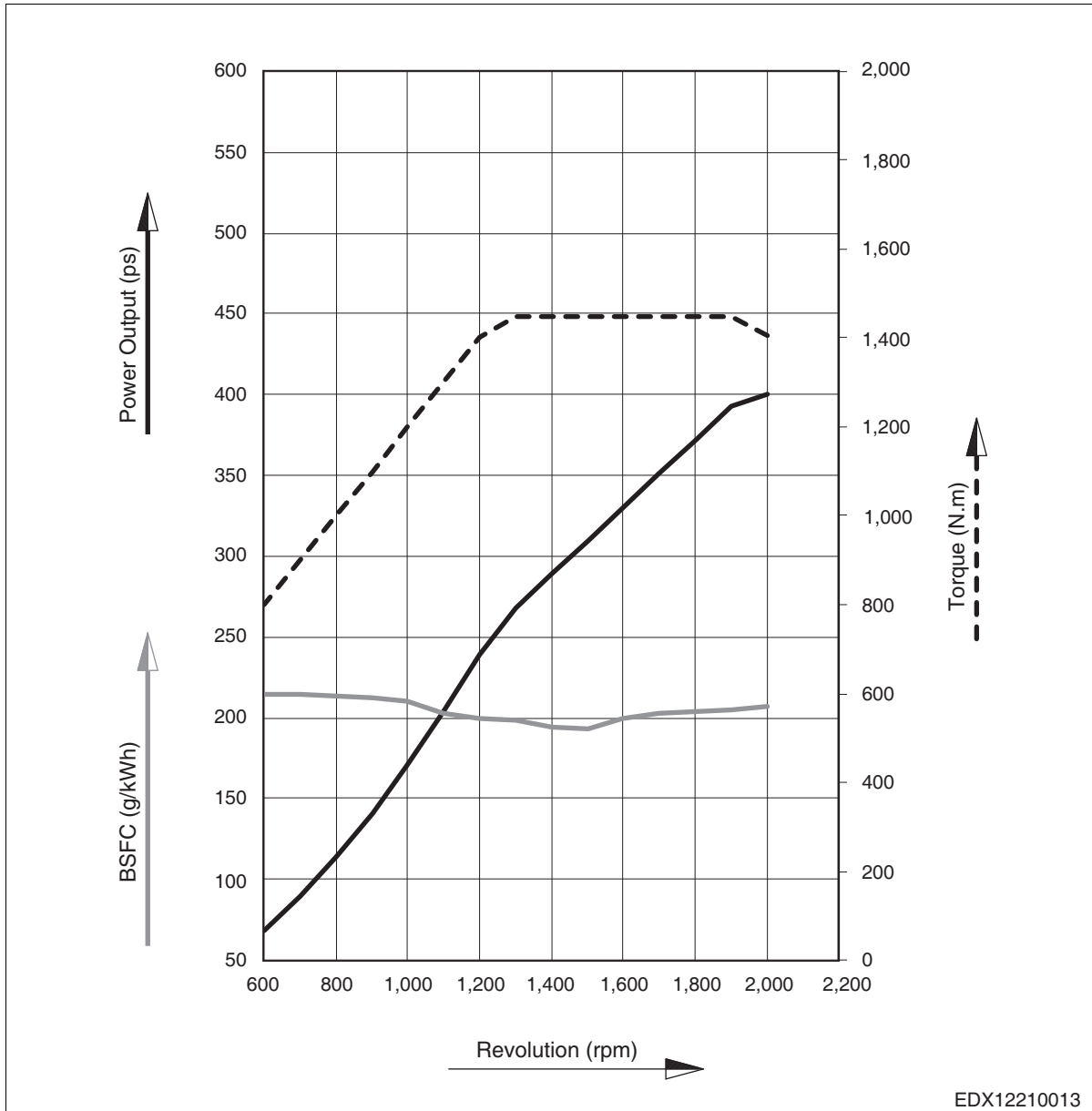

Testing and evaluation method		KS - R0071
Engine power	(max.)	400 PS (294 kW) / 2,000 rpm
Fuel consumption	(rated)	207 g/kWh

● 4L126CASC (Continuous Duty)

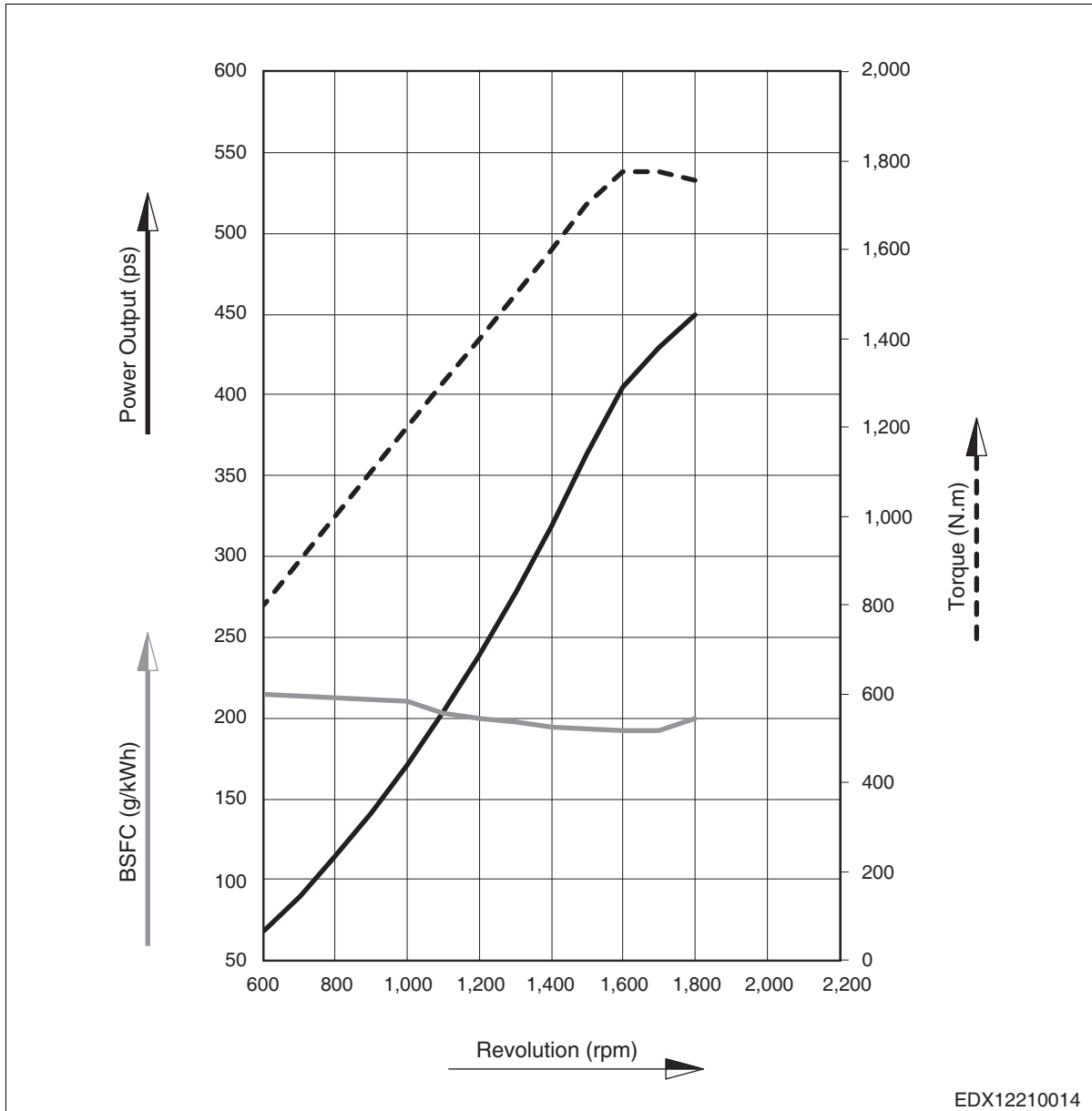

Testing and evaluation method		KS - R0071
Engine power	(max.)	450 PS (331 kW) / 1,800 rpm
Fuel consumption	(rated)	200 g/kWh

1.3.2. Performance Curve (IMO Tier3)

● 4L126CAKH-II (Heavy Duty)

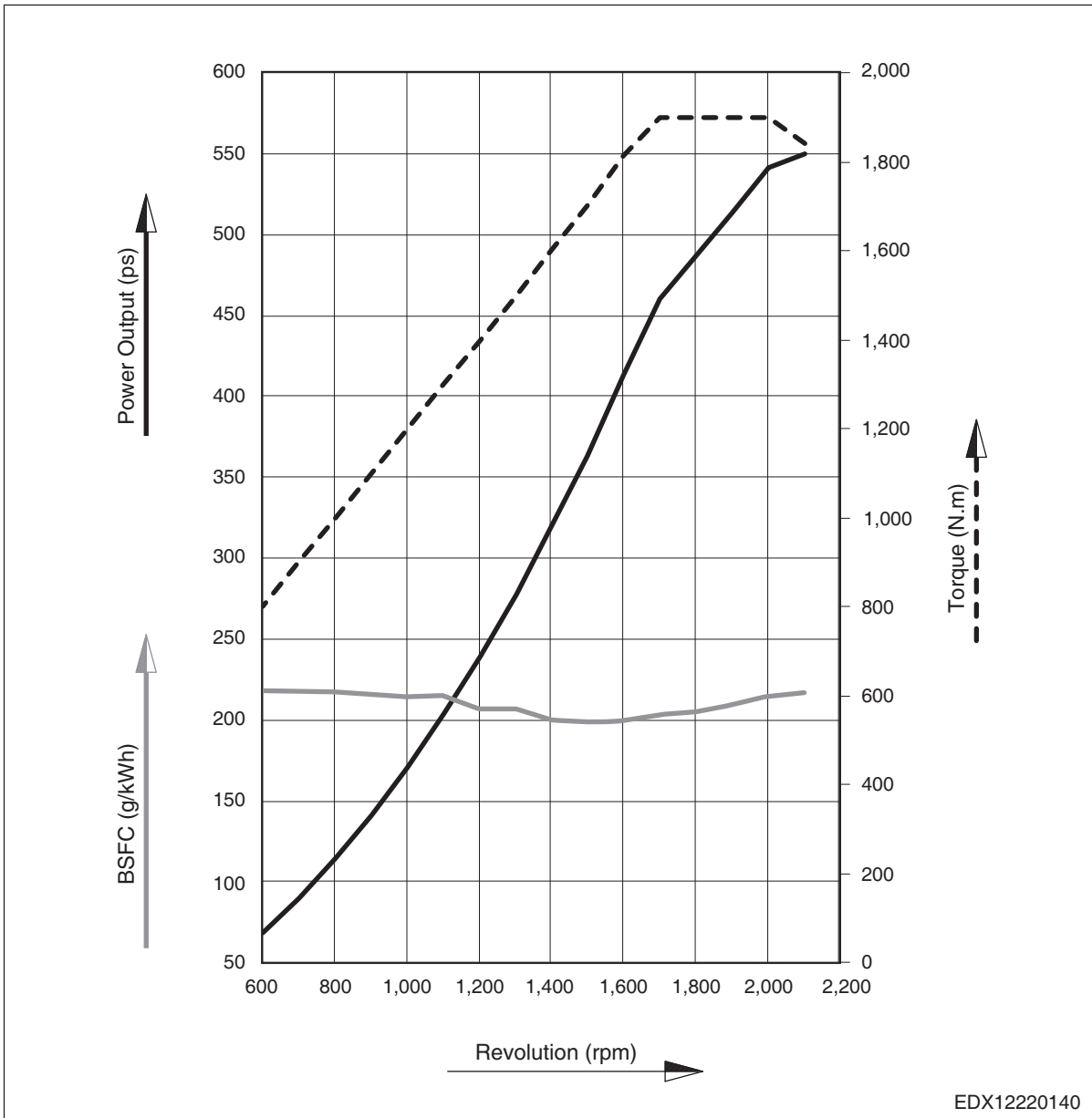

Testing and evaluation method		KS - R0071
Engine power	(max.)	550 PS (405 kW) / 2,100 rpm
Fuel consumption	(rated)	217 g/kWh

● 4L126CAKH (Heavy Duty)

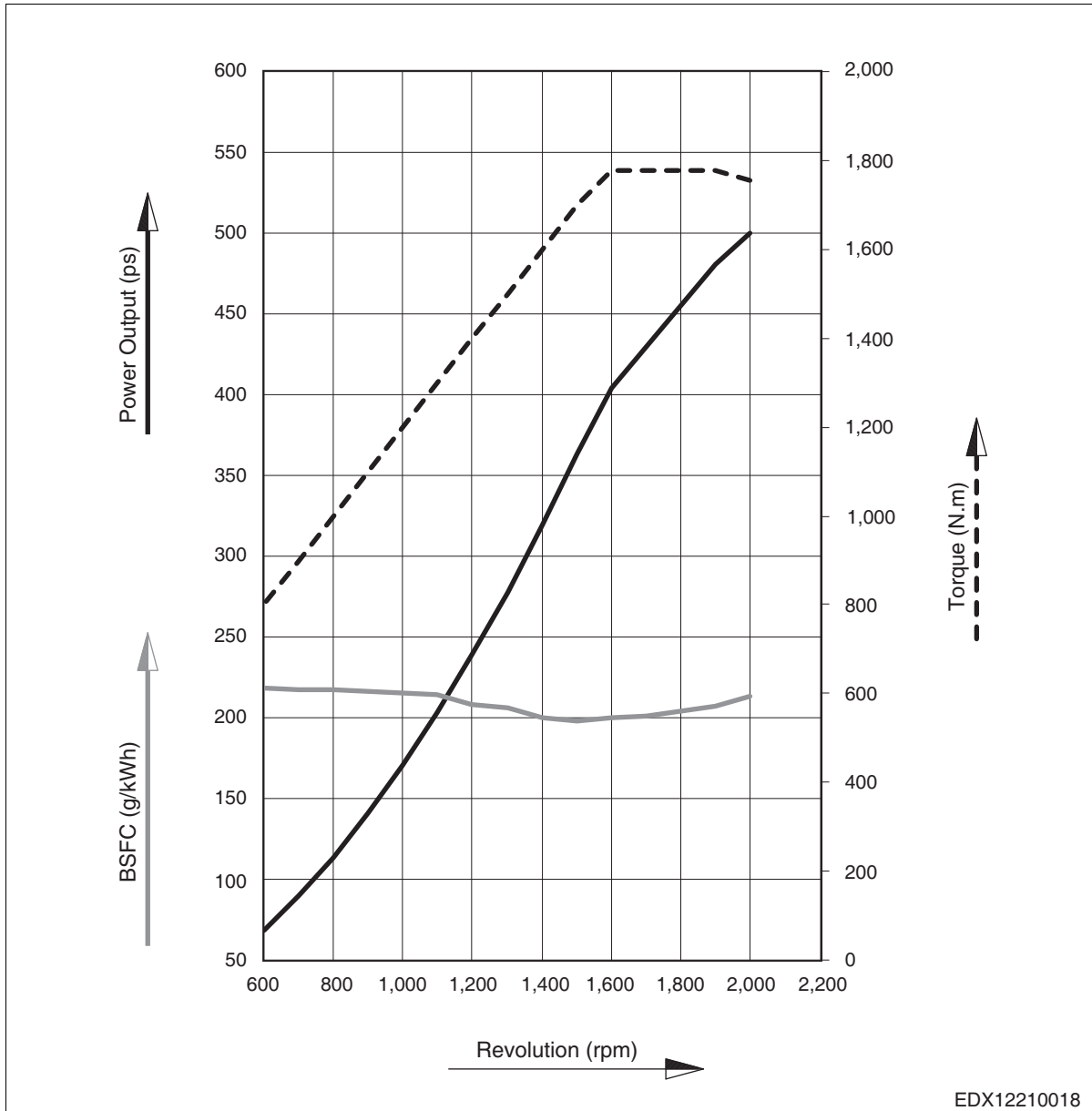

Testing and evaluation method		KS - R0071
Engine power	(max.)	500 PS (368 kW) / 2,000 rpm
Fuel consumption	(rated)	213 g/kWh

● 4L126CBKH (Heavy Duty)

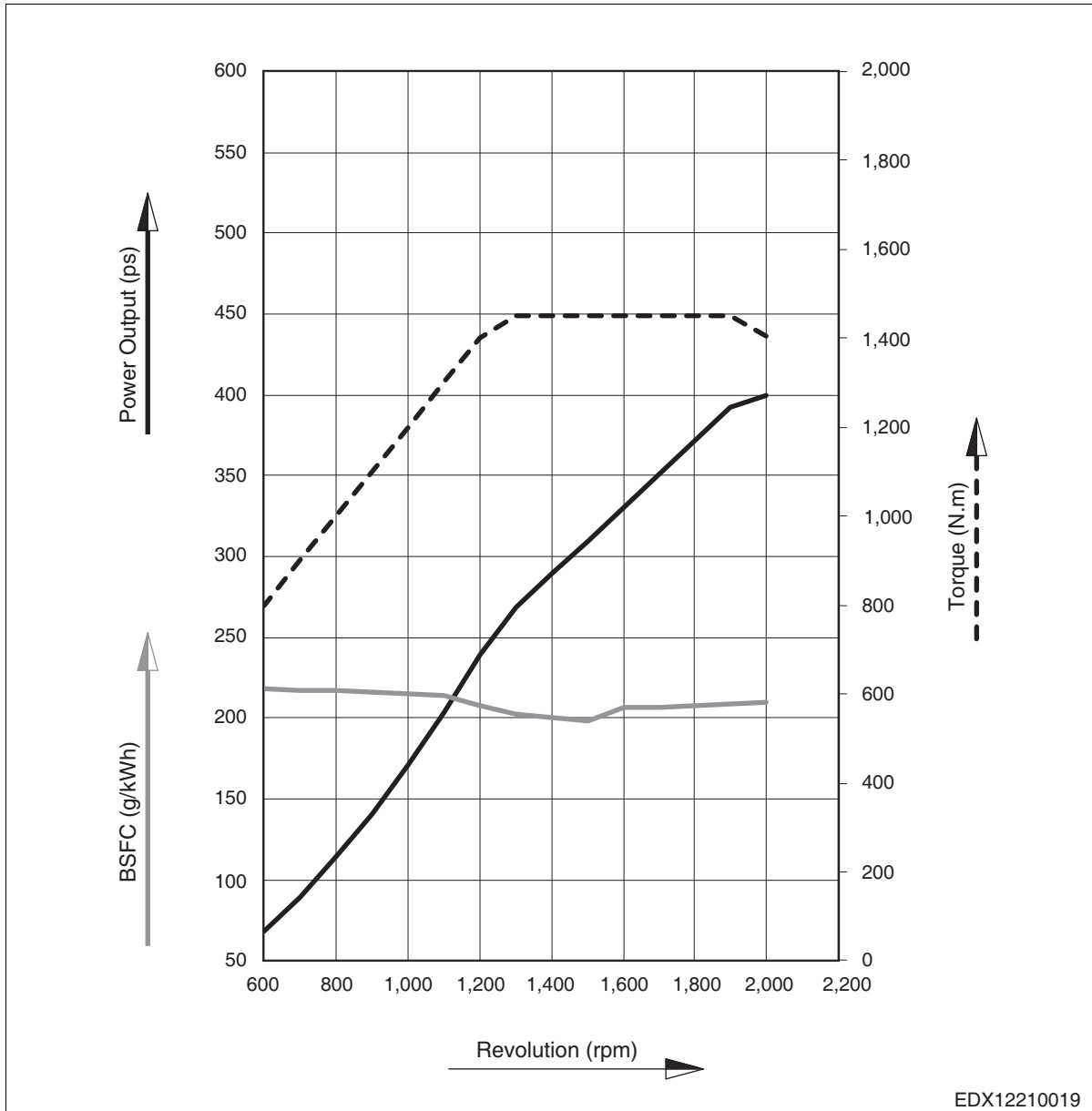

Testing and evaluation method		KS - R0071
Engine power	(max.)	400 PS (294 kW) / 2,000 rpm
Fuel consumption	(rated)	210 g/kWh

● 4L126CAKC (Continuous Duty)

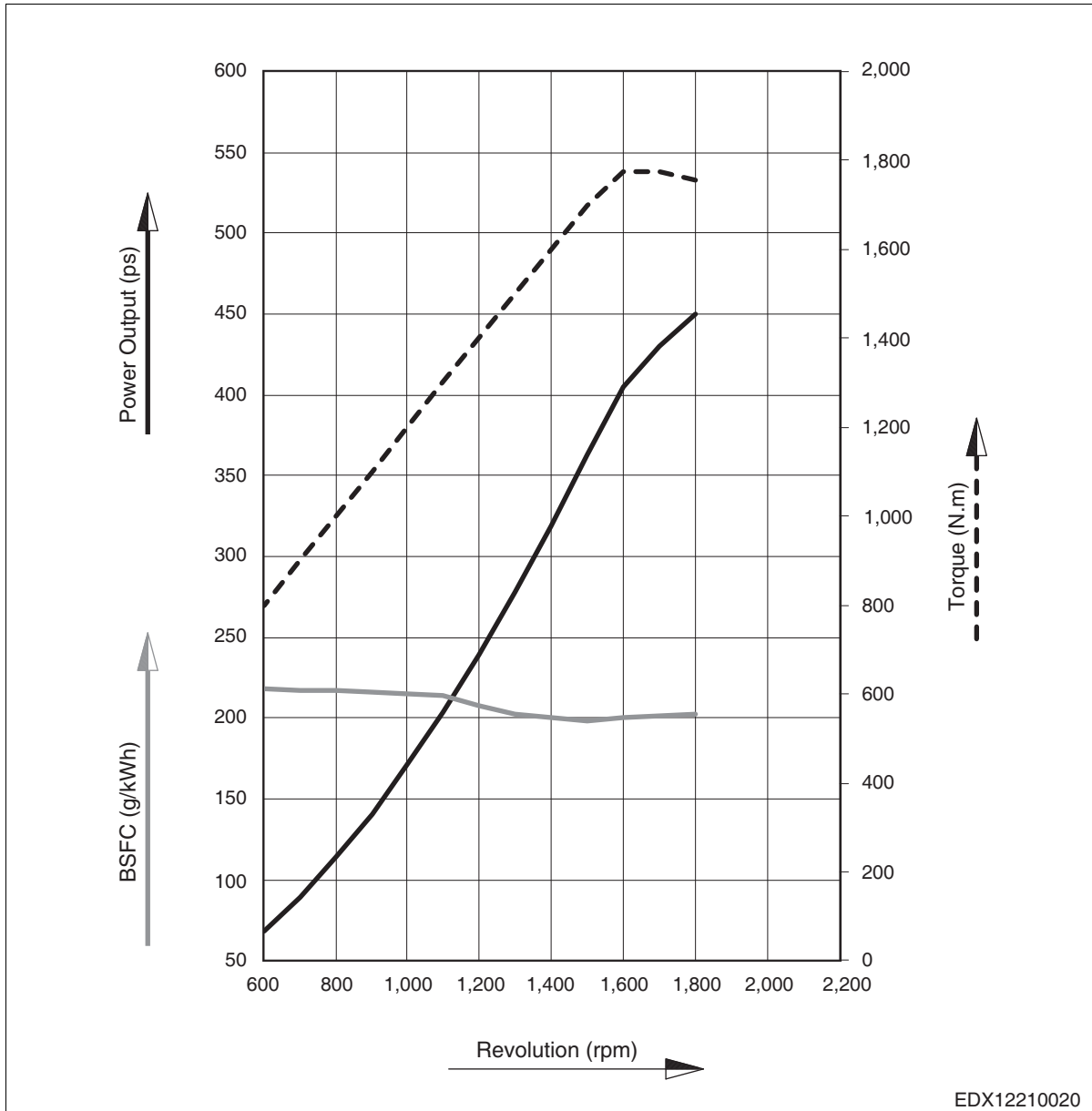

Testing and evaluation method		KS - R0071
Engine power	(max.)	450 PS (331 kW) / 1,800 rpm
Fuel consumption	(rated)	203 g/kWh

1.3.3. Performance Curve (EPA Tier3)

● 4L126CAKH-II (Heavy Duty)

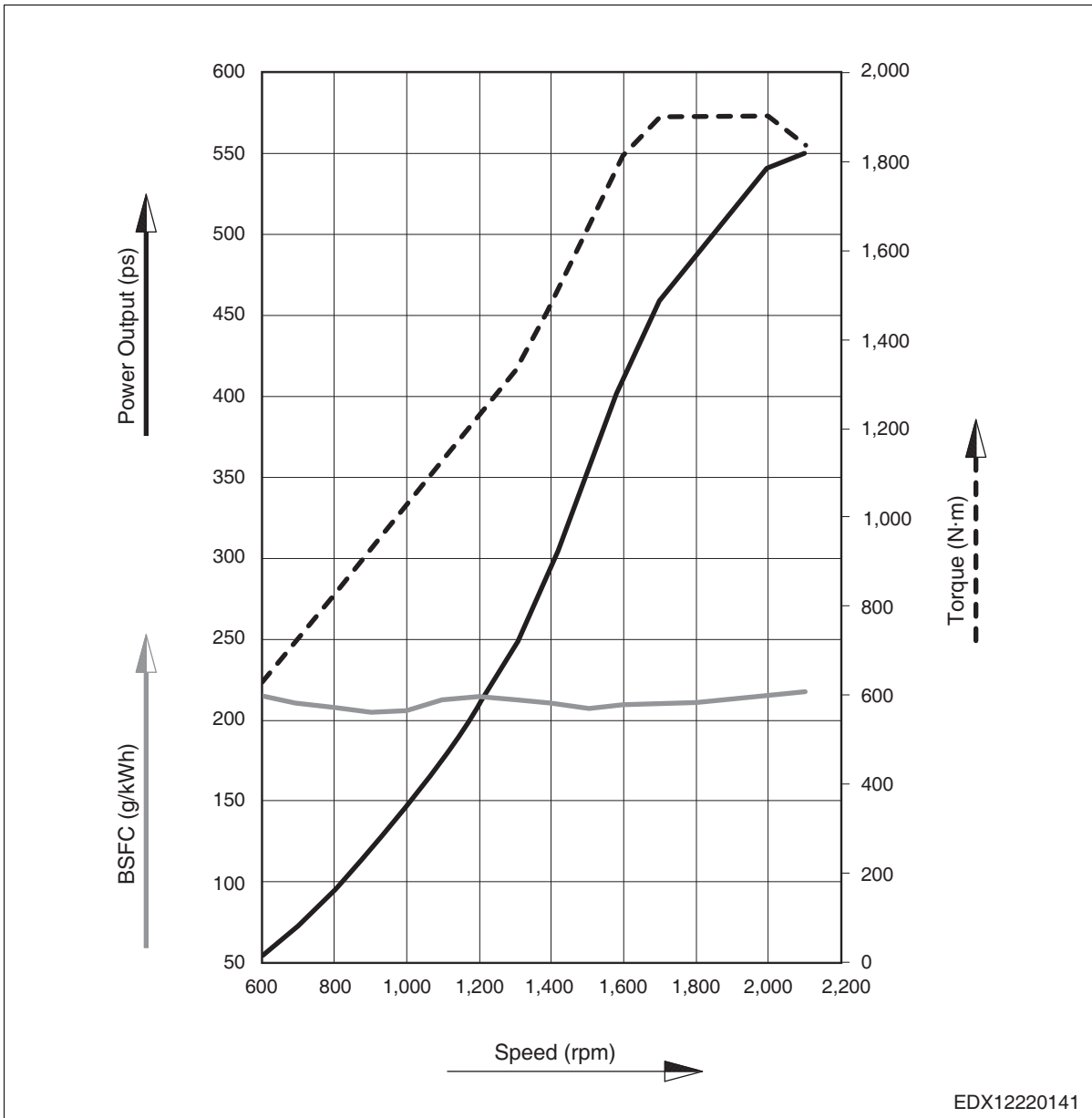

Testing and evaluation method		KS - R0071
Engine power	(max.)	550 PS (405 kW) / 2,100 rpm
Fuel consumption	(rated)	217 g/kWh

● 4L126CAKH (Heavy Duty)

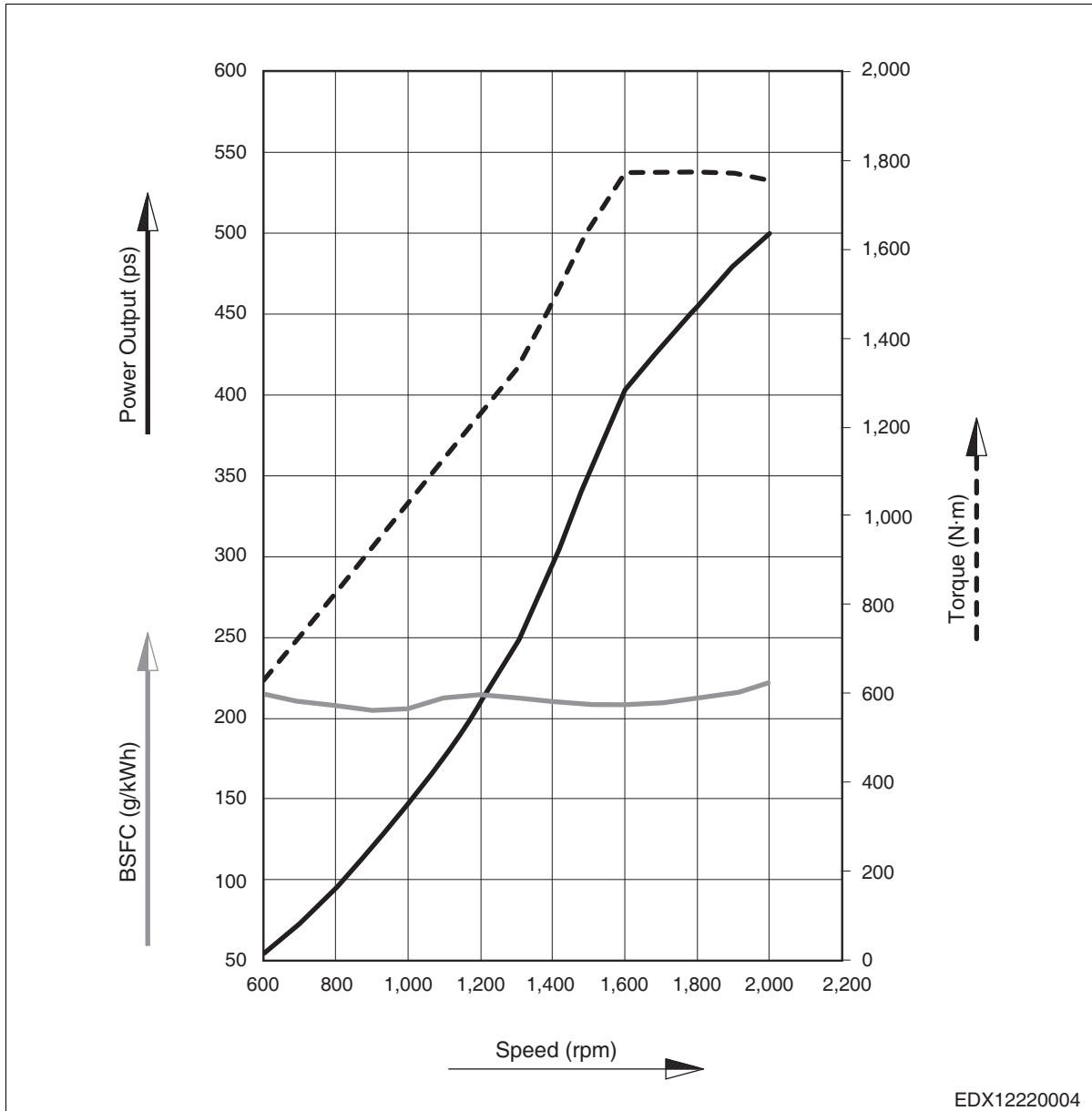

Testing and evaluation method		KS - R0071
Engine power	(max.)	500 PS (368 kW) / 2,000 rpm
Fuel consumption	(rated)	222 g/kWh

● 4L126CBKH (Heavy Duty)

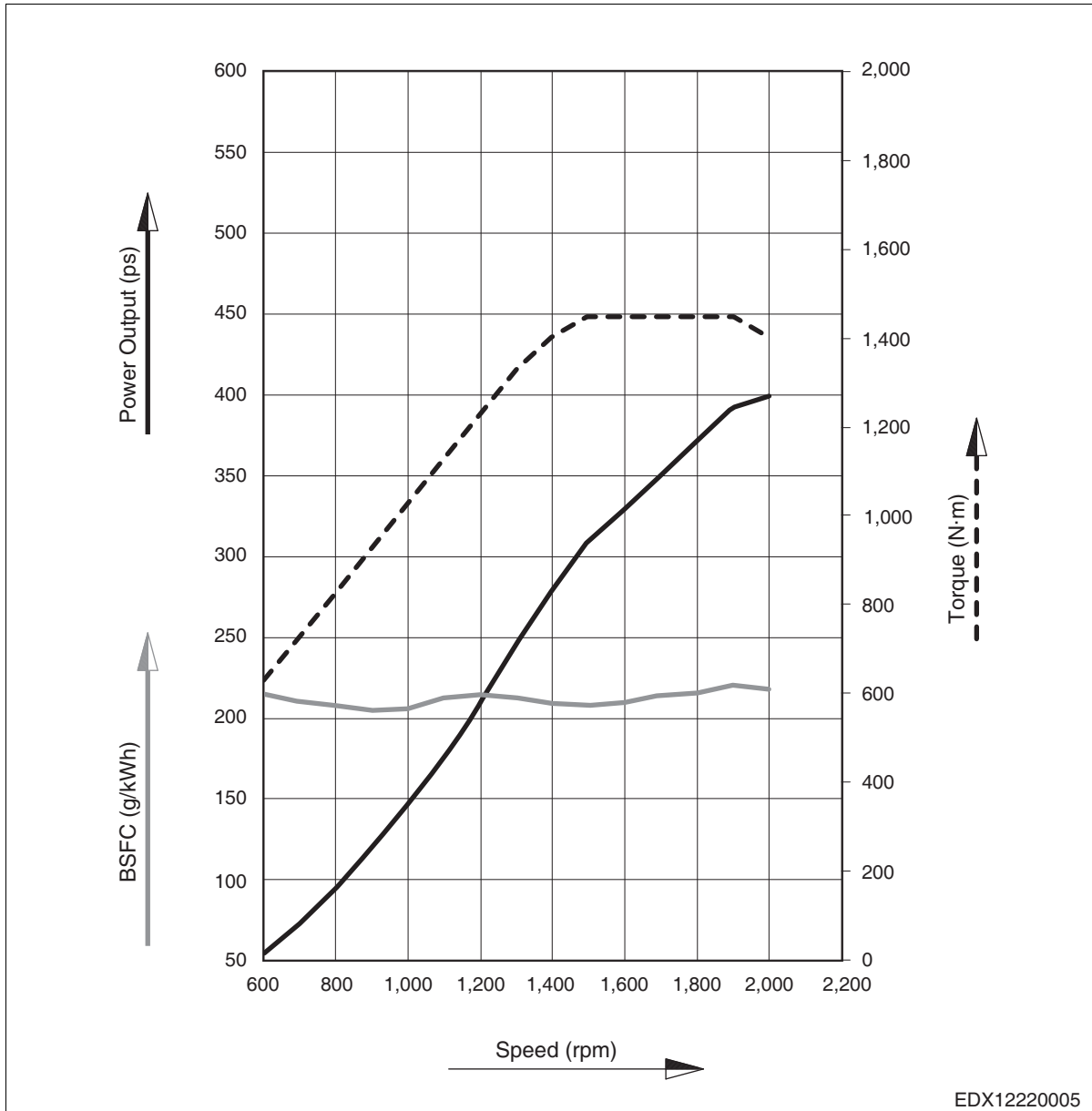

Testing and evaluation method		KS - R0071
Engine power	(max.)	400 PS (294 kW) / 2,000 rpm
Fuel consumption	(rated)	218 g/kWh

● 4L126CAKC (Continuous Duty)

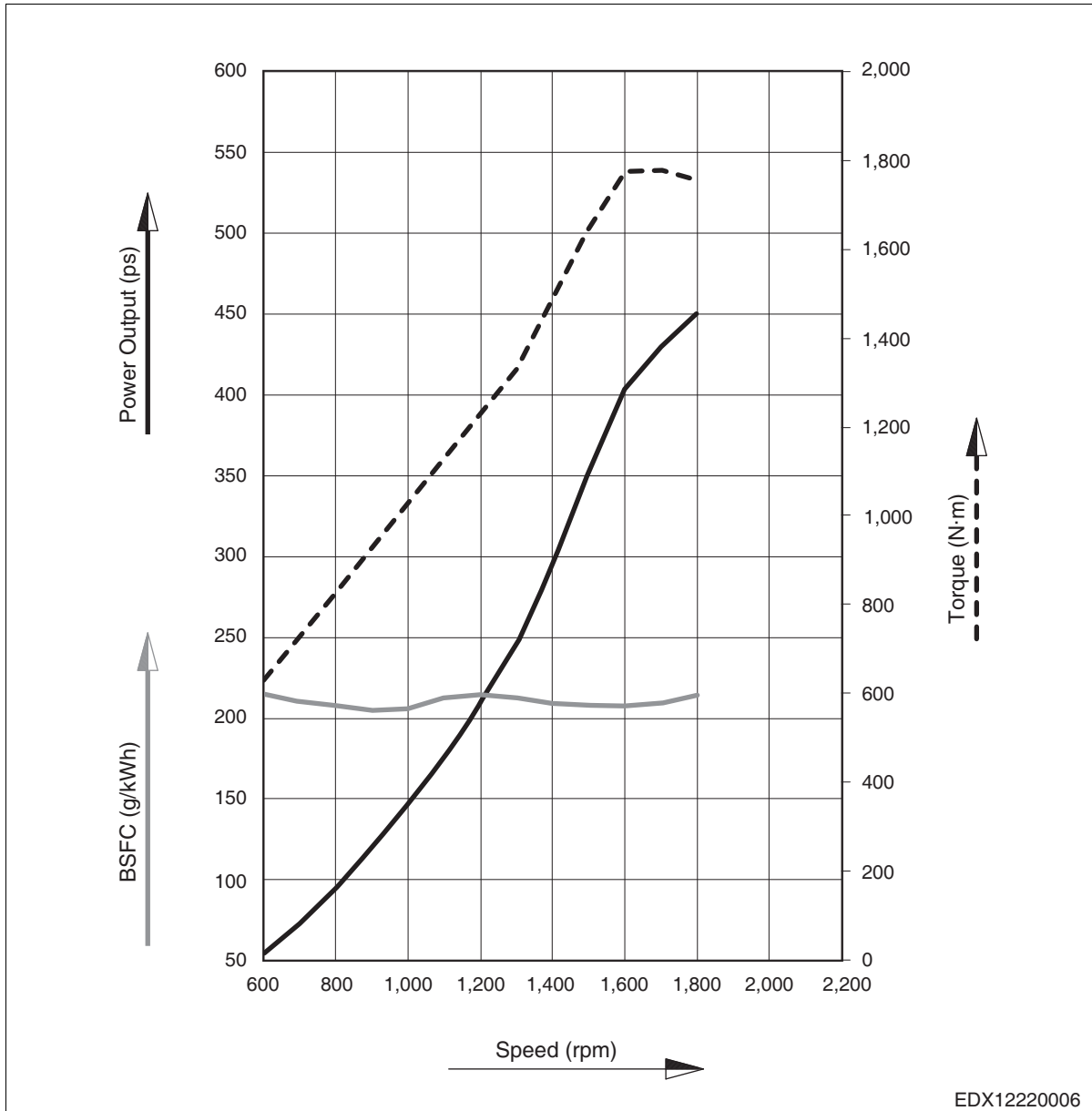

Testing and evaluation method		KS - R0071
Engine power	(max.)	450 PS (331 kW) / 1,800 rpm
Fuel consumption	(rated)	214 g/kWh

1.3.4. Performance Curve (RCD-HD)

● 4L126CARH (Heavy Duty)

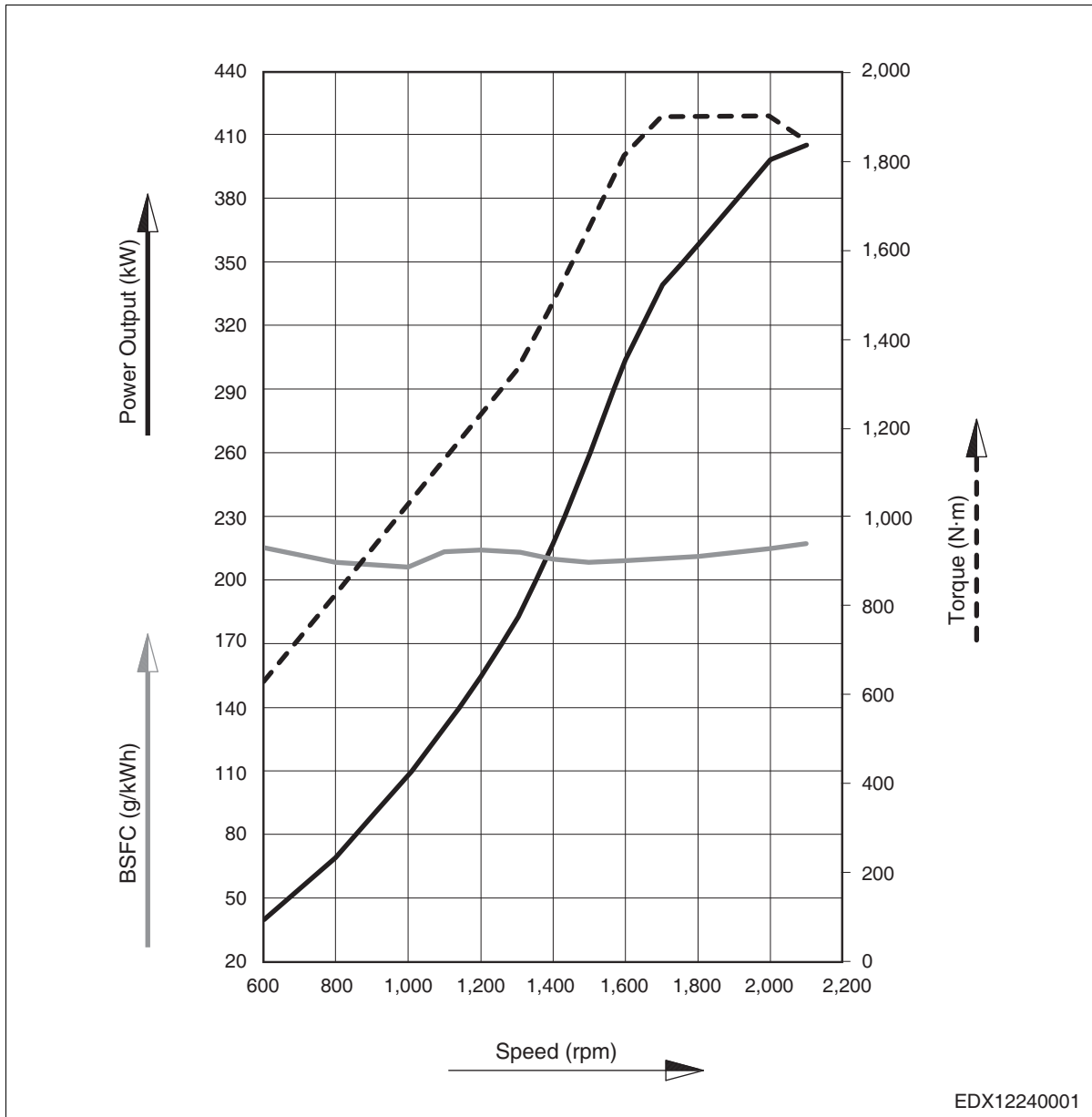

Testing and evaluation method		KS - R0071
Engine power	(max.)	550 PS (405 kW) / 2,100 rpm
Fuel consumption	(rated)	217 g/kWh

1.3.5. Performance Curve (Stage-V)

● 4L126CBVH (Heavy Duty)

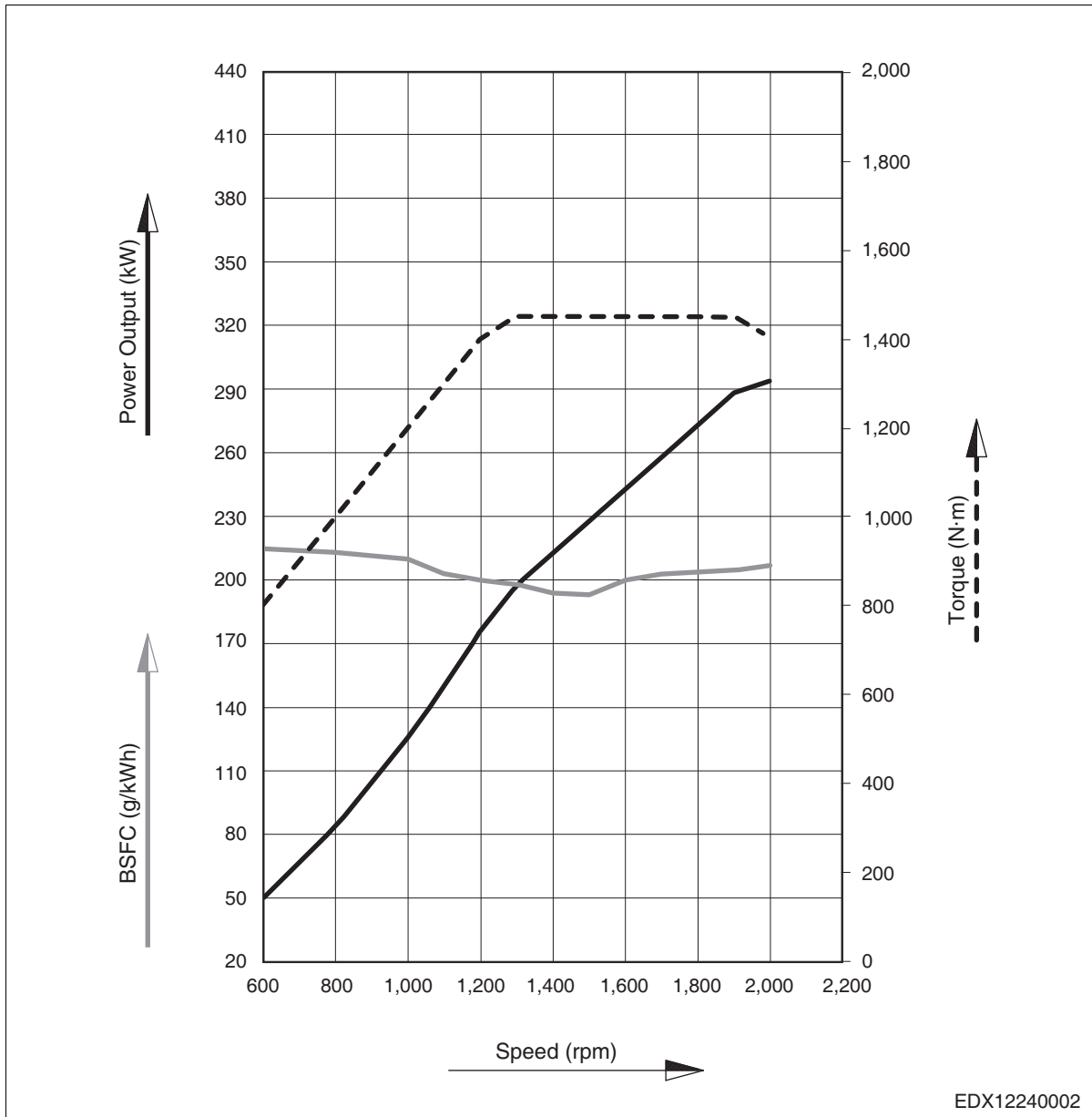

Testing and evaluation method		KS - R0071
Engine power	(max.)	400 PS (294 kW) / 2,000 rpm
Fuel consumption	(rated)	207 g/kWh

1.4. Engine Model and Serial Number

The engine serial number is engraved on the engine block as shown in the picture on the right. This number is required for warranty claims, ordering parts and ship inspections.

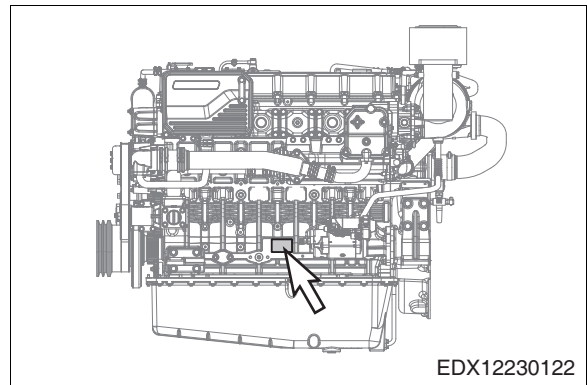

CAUTION

The engine model name is indicated on a plate attached to the cylinder block as shown in the picture on the right.

- Engine serial number (Ex. : L126TI)

ECIKM200001

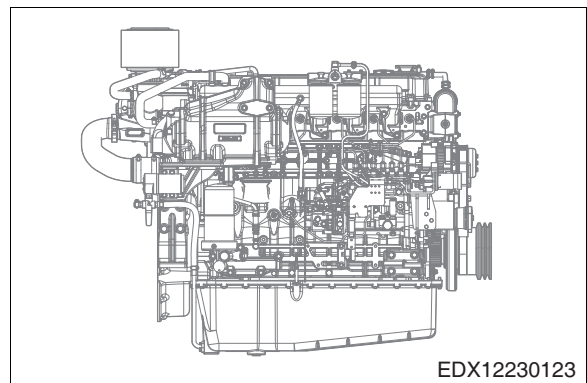
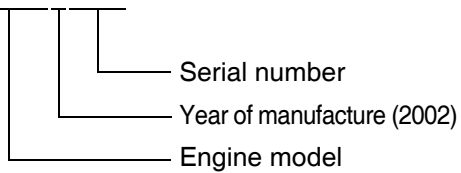

2. Safety Regulations

2.1. General Information

In order to make use of the engine safely and reliably on a daily basis, be sure to always check all engine-related matters before using it. The engine operator must familiarize themselves with the contents of this Operation and Maintenance Manual and always comply with the daily inspection and regular inspection techniques.

The contents below are a summary of the most essential rules which must be observed. The contents are divided into sections on preventing injury and property damage, as well as preventing environmental pollution. The various rules determined based on the engine specifications or region must also be followed.



Important

Seek medical assistance immediately in the event that an unanticipated accident occurs in spite of having been careful when using or servicing the engine, such as coming into contact with corrosive acid or fuel, being burnt by hot oil, or getting antifreeze in your eyes.

2.2. Rules for Preventing Injuries

2.2.1. Starting and running the engine during test operation

Before operating the engine, read the Operation and Maintenance Manual carefully first to familiarize yourself with the "Caution" items and the main inspection items related to running and operating the engine, such as the gauge panel. Please contact a HD Hyundai Infracore service center or a local technician if further explanation of any of the contents of this manual is required.

- To ensure absolute safety, place a warning label on the door to the engine room prohibiting any unauthorized personnel from entering. Also, make sure that the engine operator understands that they are responsible for safe operation in the engine room.
- The engine should be started and run only by authorized personnel. Never let any unauthorized personnel start the engine.
- Do not approach any rotating parts while the engine is running. Be sure to wear close-fitting clothes.
- The engine becomes very hot while it is running so there is a danger of being burnt. Never touch the engine with bare hands.
- Exhaust gas contains toxic chemicals so be sure to comply with the installation standards in the chapter "Exhaust System" for HD Hyundai Infracore marine engines installed in enclosed spaces such as engine rooms. Make sure the engine room is fitted with an adequate ventilation system, such as air inlets and outlets.
- Be sure to keep the area around the engine and ladders, etc. free from oil or grease. Slipping can result in serious injury.

2.2.2. Cautions for service

- Make sure to perform service work only with the engine stopped. If it is necessary to perform service work with the engine running, be careful of any possible safety accidents and scalding. Do not get too close to any rotating parts if performing service work while the engine is running cannot be avoided.
- Change engine oil while it is still warm after stopping the engine.



CAUTION

Do not touch the oil drain plug or oil filter with bare hands while the engine is running. The engine oil is hot and may cause burns.

- Check the amount of oil in the oil pan in advance so that a suitable container with a sufficient capacity can be used for changing engine oil.
- When replacing or refilling engine coolant, cool the engine off first, then wrap the coolant pressure cap on the auxiliary tank in a cloth, turn it slowly to gradually release the high air pressure built up within the enclosed circuit, and open it. Hot coolant can cause scalding and other injuries.
- Do not tighten or disconnect any pipes or hoses (engine oil circuit, coolant circuit and hydraulic oil circuit) while the engine is running. There is a risk of damages (accidents such as fires or burns) occurring due to the liquid pouring out.
- Fuel is highly flammable. Never smoke or use fire around the engine. Fueling should be performed only while the engine is stopped.
- Be sure to wear safety goggles when performing tasks which involve using compressed air, such as cleaning the heat exchanger.
- Engine service items (such as antifreeze) should be stored in properly labeled containers so as to avoid confusing them with beverage containers.
- Follow the instructions provided by the battery manufacturer when checking or handling batteries.



CAUTION

The battery fluid is toxic, corrosive and explosive. Hence, it should be handled by a professional technician.

2.2.3. Performing inspections, adjustments and repairs

- Engine inspections, adjustments and repairs should only be performed by qualified personnel.
- Use only proper tools which are in good working condition. If using a wrench with a worn and split tip, it may slip on the parts, leading to a safety accident.
- When lifting the engine with a crane, never let anyone stand or pass below it. Check the safety condition of the crane before working with it.
- When measuring the pressure in the injection nozzles, keep hands away from the spot where fuel is injected. The high pressure may cause safety accidents. Be careful not to inhale atomized fuel in the air.
- When working on the electrical system, be sure to disconnect the battery ground cable ("- (negative) cable) first. In order to prevent a short circuit, perform a final inspection before reconnecting it.

2.3. Preventing Engine Damage and Premature Wear

- 1) The customer must not attempt to exceed the set continuous maximum power of the engine provided by HD Hyundai Infracore for any other purposes.
For more details, refer to "5. Main Auxiliary Devices." Never attempt to modify the fuel injection pump without prior written consent from HD Hyundai Infracore.
- 2) If any problems occur while running the engine, find the cause and resolve the problem immediately to ensure that severe damage does not occur afterwards.
- 3) Use only genuine HD Hyundai Infracore spare and service parts for inspections and maintenance. HD Hyundai Infracore is not responsible for engine damage occurring as a result of using imitation parts.
- 4) Make sure to observe the following instructions as well as the instructions above:
 - Do not operate the engine without oil or coolant.
Use only service items (engine oil, antifreeze, anti-corrosive agents, etc.) recommended by HD Hyundai Infracore.
 - Keep the engine clean. Diesel fuel must not contain any water.
 - Refer to "4.6. Fuel System" in the Operation and Maintenance Manual.
 - Follow the specified maintenance schedule for the engine, referring to "4.2. Daily Inspections and Regular Inspections."
 - Do not stop the engine immediately while it is hot after being run. Instead, idle it for approx. 5 minutes without any load so that its temperature drops naturally, then stop the engine.
 - Do not pour cold coolant into an overheated engine. Parts may be damaged.
 - When adding engine oil, do not exceed the upper limit indicated on the oil gauge.
When mounting the engine, be careful not to exceed the maximum allowable inclination angle.
Failing to comply with the guidelines in this Maintenance and Operation Manual can cause severe damage to the engine.
 - Check that the testing and monitoring devices (for the battery, oil pressure, coolant temperature, etc.) are always working properly.
 - Do not run the saltwater pump in a dry state. Drain coolant after stopping the engine if there is a risk of it freezing.



CAUTION

Do not spray high-pressure water directly on the engine. It may damage engine parts, electronic parts, and wiring.

- Only use clean fuel with the specified grade. Please use the fuel recommended in this Operation and Maintenance Manual.



CAUTION

Using imitation or unspecified fuel may cause severe faults in the engine.

2.4. Rules for Preventing Environmental Pollution

2.4.1. Engine oil, filter element, fuel filter

- Used oil should be collected in an oil disposal container. Be especially careful not to allow oil to spill onto the ground or into the sea. Spilled oil can pollute sources of drinking water.
- Oil and fuel filter elements are classified as environmental pollutants and must be disposed of according to the relevant laws.

2.4.2. Coolant

- Undiluted anti-corrosive agents or antifreeze should be disposed of as hazardous waste.
- When disposing of used coolant, follow the applicable local regulations.

2.5. Safety Matters for Handling Used Engine Oil

If your skin comes in contact with engine oil for an extended period of time or repeatedly, it can lead to skin irritation.

As can be seen in the results of experiments on animals, used engine oil contains harmful substances which may cause skin cancer. When handling engine oil in the workplace, there is no cause for serious concern about health risks arising from handling oil if basic hygiene and workplace safety rules are followed.



Health Precautions

- Avoid repeated or prolonged skin contact with used engine oil.
- Protect the skin with a suitable skin protection product (cream, etc.) or wear protective gloves.
- If skin comes into contact with engine oil, wash it off immediately as follows.
 - Wash the skin clean with soap and water, using a brush for nails, etc.
 - Readily available commercial products for cleaning off grease easily and effectively can also be used.
 - Do not use gasoline, diesel fuel, gas oil, thinner or solvents, etc. to clean oil off skin.
- After washing the skin, apply lotion to it for protection.
- Wash fuel- or oil-stained clothes or shoes before wearing them.
- Do not carry fuel- or oil-stained rags, etc. in your pockets.



Check to ensure that used engine oil is disposed of properly.
Improperly discarded engine oil can pollute drinking water.

Hence, never spill used engine oil into the ground, ditches or drains.

Failing to comply with disposal regulations is punishable by law, so please take care to dispose of engine contaminants (oil, fuel, antifreeze, etc.) according to the relevant regulations. For details regarding disposal procedures, contact the distributor, supplier or local agency.

2.6. Cause of Electrolytic Corrosion

One of the most important causes of corrosion of metal parts in salt water is interference current from the ship's electrical system. These currents may be very weak and are often hard to detect. However, if they are active over prolonged periods of time, they may cause heavy corrosion.

Electrolytic corrosion may be prevented by a suitable electrical wiring.

Marine engine installations require special grounding of electrical system components to minimize electrolytic corrosion from stray currents and to minimize radio interference.

On metallic the boats the hull may serve as the common bonding conductor and a separate bonding system may not be required.

3. Operation

3.1. Inspection Items Before Running the Engine

3.1.1. Lubricant

- The oil level should be between the upper and lower limits on the oil level gauge.
- The oil level must be measured in a horizontal state without any waves.
- Check the oil smeared on the oil measuring gauge for its viscosity and level of contamination. If necessary, replace or refill the engine oil.

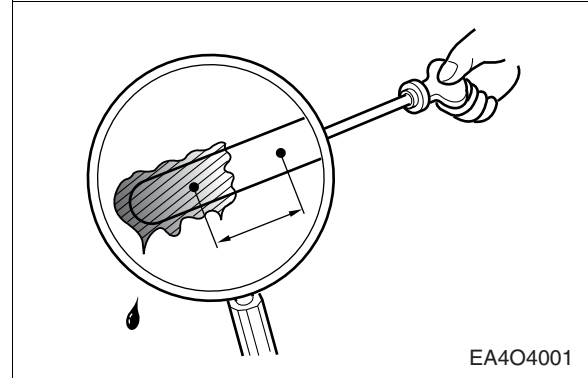

CAUTION

The upper and lower limit marks indicated on the oil level gauge may differ depending on the inclination of the engine installed. When running the engine for the first time after installation, fill the engine oil to its maximum capacity and check whether it matches up with the upper limit on the gauge. If they differ from one another, readjust the upper and lower limit marks to suit the angle of inclination of the engine installed.

(Engrave the maximum and minimum markings on the oil level gauge while referring to 4.4 "Fuel System.")

3.1.2. Coolant

Add coolant if the level is low. The pressure cap serves to raise the boiling point and to prevent phenomena such as cavitation which create air bubbles in the engine. Use the expansion tank cap tester to check the opening pressure of the pressure valve. If the measurement is below the standard value, replace the coolant cap. (Opening pressure of pressure valve: 0.9 kg/cm²)

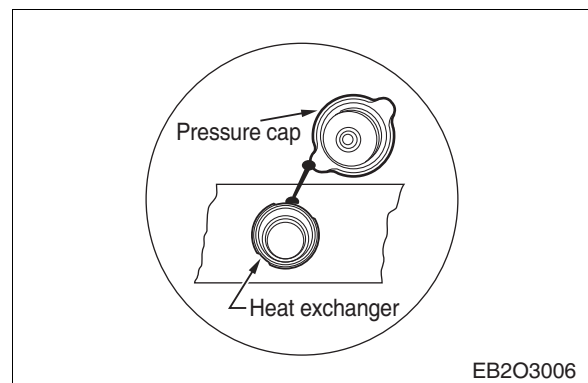

3.1.3. Saltwater pump

The inlet and outlet on the saltwater pump differ depending on the rotating direction of the shaft.

- The load caused by overtightening the belt or gears shortens the pump life.
- Do not run the saltwater pump in a dry state for more than 20 seconds.
- Check whether all of the valves and plugs in the saltwater system are open before running the engine.
- If there is a risk of freezing, open the rear cover on the saltwater pump and drain the water.
- Operating temperature range : 5 - 60 °C

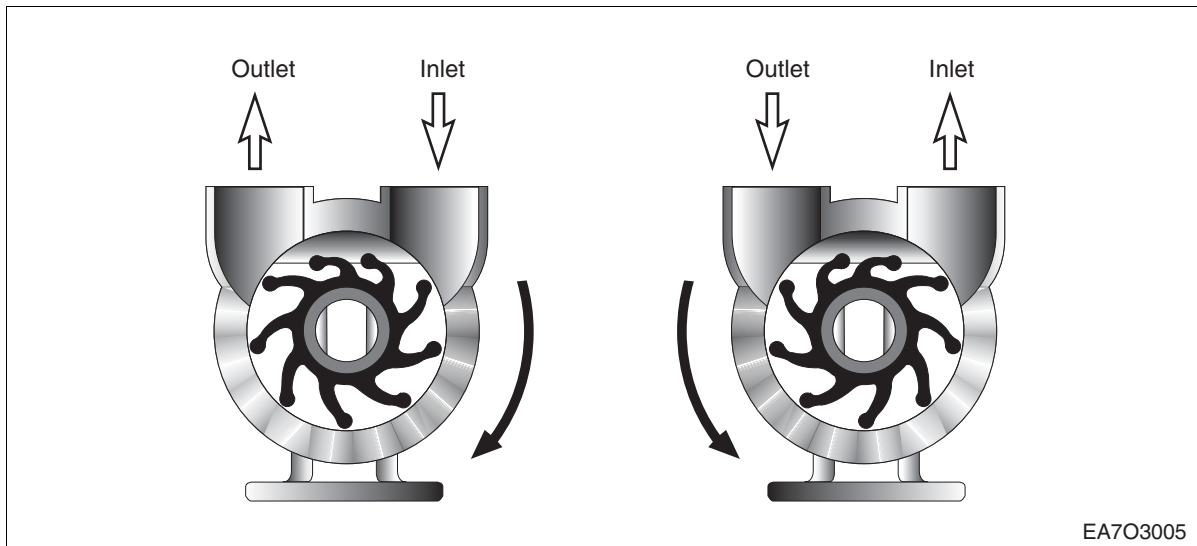

3.1.4. Intake/exhaust manifold

Check whether contamination, rust or clogging, etc. is causing excessive resistance in the intake/exhaust manifolds.

3.1.5. Fuel line

Open the valve on the fuel line and check for any leaks, etc.

3.1.6. Inspecting the floor of the ship

Check whether there is an excessive accumulation of water on the floor of the ship in the engine room. The ship's floor should always be clean and dry. An excessive accumulation of water on the ship's floor can lead to corrosion of the engine and fires due to short circuits in the various electrical components. In order to prevent water from accumulating, install a water drain pump with an automatic adjustment switch on the ship's floor.



CAUTION

When the ship is run at full speed, the longitudinal inclination of the ship becomes higher, increasing the height of the water accumulated on the ship's floor.

An excessive accumulation of water on the ship's floor increases corrosion in the engine, leading to severe malfunctions.

3.1.7. Engine stopping and warning devices

In addition to an automatic stopping mechanism, the gauge panel is equipped with a warning lamp and warning device which warn the operator in the event that one of the following problems occurs.

1) Engine stopping mechanism

The engine stops while the warning lamp blinks and a warning buzzer sounds in the following cases:

- Low engine oil pressure (1 bar or less @ 600 rpm, based on gauge pressure)
- High engine coolant temperature (105 °C or higher)
- Engine overspeeding (over 117% of the rated rpm)
- Abnormal common rail pressure (open common rail relief valve, max. common rail pressure exceeded, etc.)
- Leaking fuel line

2) Speed limiter (propulsion engine), torque limiter (auxiliary engine)

The engine warning lamp turns on, a warning buzzer sounds, and the speed and torque of the propulsion engine and auxiliary engine are limited, respectively.

Speed limit of propulsion engine : Limited to MD 1,900 rpm, HD 1,800 rpm, CD 1,600 rpm.

Torque limit of auxiliary engine: Limited to 50% of the rated power.

- Abnormal sensor voltage (coolant temperature sensor, cam sensor, oil pressure sensor)
- High fuel temperature (70 °C or higher)
- High oil temperature (130 °C or higher)
- High turbocharger air temperature (90 °C or higher)
- Turbocharger air leak (leak in rear of turbocharger)
- Faulty CP metering unit
- High SCR pressure difference (clogged SCR)
- Abnormal common rail pressure

3) Engine warning mechanism

The engine warning lamp blinks and a warning buzzer sounds.

- Refer to the list of fault codes for engine warning devices



If the warning lamp on the gauge panel above turns on after starting the engine, follow the procedure below.

First, determine which system has the problem and whether the needles on each gauge are moving abnormally. Then, immediately check each warning lamp. If the engine coolant is overheated, switch to an idling speed immediately and put the reduction gear control lever in the neutral position. Confirm the cause of the warning and do not start the engine again until it has been repaired.

Refer to the "Overheating" troubleshooting section in the service manual. If the coolant temperature gauge indicates a high coolant temperature, check whether there is not enough coolant, the heat exchanger is contaminated or the temperature sensor is malfunctioning.

If the cause of the warning cannot be determined, please contact a HD Hyundai Infracore dealership.

3.2. Starting

3.2.1. Operating Techniques

This involves booting up or shutting down the digital panel system, as well as stopping the engine.

- 1) Using the key included with the product, insert it into the key switch and turn it 90° to the right (ON)
(If the key is "ON," keep the key switch turned on)
- 2) When turned "ON," the product boots up and the gauge screen is displayed in approx. 17 seconds
- 3) When turning the system off, turn the key 90° to the left (OFF)
 - When the key is turned to the left (OFF) while the engine is running, an alarm pop-up message appears on the screen for 300 seconds. Then 300 seconds later, the engine stops and the event is saved.
 - If the key is turned to the right (ON) when the pop-up window is on the screen, the pop-up window disappears and the engine keeps running.

For details, refer to the enclosed Digital Panel Service Manual for Ships.

3.3. Operation

In order to achieve maximum engine performance and prolong its service life, the engine must be broken in during the initial 50 hours.

3.3.1. Engine break-in

HD Hyundai Infracore marine engines are run only for a short period of time for their final test at the factory. Therefore, the break-in procedure should be performed for the initial 50 hours of operation in order to ensure optimum performance and prolonged service life.



CAUTION

Check to make sure that the lubricant is suitable during the engine break-in period.

After the 50-hour break-in period is complete, replace the lubricant supplied at the factory with fresh oil.

3.3.2. Initial two-hour break-in

During the first 5 - 10 minutes of operation, run the engine at a high idling speed (1,500 rpm or less). For two hours, increase the speed of the ship gradually, then reduce the load in order to maintain the idling speed.

During this time, slowly increase the engine speed to approx. 1,500 rpm and then lower it again repeatedly at two- to three-minute intervals. Once the engine coolant reaches a suitable temperature, the engine speed will decrease slightly.

Then, increase the engine speed to start breaking in the rings (piston rings, oil rings, etc.) and bearings. During this time, be careful not to run the engine at more than 1,500 rpm.



CAUTION

During the initial two-hour break-in period, be sure to avoid running the engine continuously at a consistent speed without any change in the rpm.

3.3.3. The following 18 hours of break-in

Following the initial two-hour break-in period, for 18 hours, take turns slowly changing the engine rpm from an idling speed to approx. 1,800 rpm (3/4 load) repeatedly. Reduce the rpm to an idling speed occasionally in order to cool the engine. During the 18-hour break-in period, the engine can be run at full speed (2,000 rpm) twice for two minutes or less.



CAUTION

During the 18-hour break-in period, be careful not to run the engine continuously at a consistent speed for an extended period of time.

3.3.4. The final 30 hours of break-in

During the final 30 hours, the engine can be run at full speed (2,000 rpm) once for 5 - 10 minutes.

Once the engine coolant reaches a suitable temperature, the speed drops slightly for a moment. Following this, run the engine continuously at a 3/4 load (1,800 rpm).

Reduce the engine speed to an idling speed at two- to three-hour intervals occasionally in order to cool the engine.



CAUTION

During the break-in period, be careful not to run the engine continuously at a consistent speed for an extended period of time.

During the initial break-in period, check the engine oil level frequently. Be sure to check that the oil level remains between the "upper limit" and "lower limit" marks on the oil level gauge.



CAUTION

The oil pressure may fluctuate slightly following changes in the engine rpm.

Also, the oil pressure tends to be higher at the same engine speed when it is hot than when it is cold.

Replace the engine oil and filter when the break-in period (50 hours) ends.

3.3.5. Operation After Break-in Period

When running the engine in cold weather, always warm the engine up gradually.

Avoid running the engine at full speed until it reaches the normal operating temperature.

Oil consumption is high until the piston rings are seated. Hence, check the oil level frequently during the initial 50-hour break-in period.

Idling the engine for extended periods of time can cause oil leaks in the turbocharger, so avoid idling the engine continuously for more than 12 hours.

3.4. Inspection After Starting the Engine

Always check the engine oil pressure gauge while running the engine. If a drop in engine oil pressure is indicated on the gauge panel, stop the engine immediately. The charge warning lamp for the generator must be turned off while running the engine.

- Make sure that the '+' and '-' terminals on the battery are connected firmly without any gaps.
- If the battery charge warning lamp comes on and the engine stops suddenly while driving, check the electrical system for a wiring malfunction.
- If an abnormal condition, such as abnormal emission color, noise or odor, occurs while driving, stop the engine to find and correct the cause.

3.5. Inspection After 50-Hour Break-In

In order to ensure safe operation of the ship, contact a HD Hyundai Infracore marine engine dealership after the 50-hour engine break-in period to have a comprehensive inspection performed on the engine as follows.

- Replace the engine oil and oil filter
- Check the coolant level
- Check the drive belt tension
- Check for vibrations in the brackets, etc. installed in the engine and the tightness of screws
- Parts prone to oil and water leaks, malfunction of the gauge panel, vibrations in various shafts, matters related to the ship speed, etc.

Fixing minor problems at this time can prevent major engine malfunctions caused by an accumulation of problems later, enabling the engine to be used confidently and safely.

3.6. Running the Engine in Winter

3.6.1. Prevention of Coolant Freezing

If antifreeze is not used, it may cause corrosion to spread within the engine, as well as reducing cooling efficiency and causing engine freezing in winter.

Hence, be sure to drain coolant completely after operating the engine. As frozen coolant can damage the engine severely, make sure to add antifreeze to it.

(Amount of antifreeze : 45% of coolant capacity)

3.6.2. Prevention of Engine Overcooling

If the engine is cooled excessively, it can lead to poor heat efficiency, increased fuel consumption and increased cylinder liner wear. Therefore, the engine should not be cooled excessively. If the coolant temperature does not reach a normal level (79 - 94 °C) even after running the engine continuously, check the thermostat or various coolant lines.

3.6.3. Lubricant

The viscosity of engine oil increases in cold weather, which may cause the engine speed to be unstable after the engine is started.

Using lubricant for winter (SAE 10W40 or 10W30) prevents this type of instability. This prevents instability. (Refer to section 4.4.)

3.6.4. Running the Primary Fuel Filter (Oil-Water Separator) Heater

In winter and in cold temperatures, the paraffin in diesel forms a gel and blocks the surface of the cartridge in the primary fuel filter, resulting in restricted fuel flow. In such cases, engine start-up may be delayed/impossible, the engine rpm may be unstable after engine start-up, or the engine may turn off. To prevent this phenomenon, turn the key on and run the heater mounted on the primary fuel filter (oil-water separator) three minutes before starting the engine to remove the paraffin from inside the primary fuel filter and the paraffin gel entering continuously from the fuel tank.

3.7. Servicing and Checking Engine Parts After Prolonged Operation

Inspecting the engine after prolonged operation restores engine performance and enhances engine durability against wear, corrosion and deterioration of its components.

Unpredictable malfunctions and defects can occur in weak points after an extended period of operation time under normal operating conditions. In such cases, repairing or correcting only one or two components cannot restore or enhance the engine performance. It is necessary to analyze the cause in detail precisely to replace or correct components that are related to or can affect the engine power and performance.

Proactive failure prevention measures for the engine can ensure long and safe operation with enhanced reliability.

It is recommended to perform preventive inspections for engine components in spring after winter has ended. The following components need to be inspected during the preventive inspections as they can affect the engine power and performance:

- Components which can affect intake and exhaust ;
Air filter, intercooler, turbocharger, muffler, engine room ventilation device, etc.
 - Components that can affect lubrication, cooling and vibrations ;
Air filter, oil filter, antifreeze, heat exchanger, rubber impeller, saltwater filter, Kingston valve, central balance of axles, strength of engine mounting support, deflection of the propeller, etc.
- 1) Fuel Tank
Sludge resulting from chemical reactions among foreign matter such as condensate and moisture, various acidic substances, and microbes which breed in such environments form continuously in the tank. Accordingly, make sure to remove contaminants and wash the tank periodically; otherwise, foreign matter may enter the high-pressure fuel injection system of the engine, causing critical damage such as wear, corrosion and clogging in the engine injection system, as well as excessive maintenance expenses.
 - Condensate: Occurs when moisture in the air condenses on the inner wall of the tank due to the temperature difference between the fuel and the air
 - Foreign matter: Constantly enters through the fuel container and the air ports on the tank
 - Microbes: Constantly enter through the air port on the tank
 - 2) Primary fuel filter and cartridge (oil-water separator)
Make sure to use genuine parts, comply with the specified replacement intervals, and periodically remove moisture stored in the filter to prevent it from entering the high-pressure fuel injection system of the engine.
 - 3) Secondary fuel filter and element
Make sure to use genuine parts, comply with the specified replacement intervals, and take care to prevent foreign matter from entering the high-pressure fuel injection system of the engine.
 - 4) Normal state of common rail and high-pressure pump wiring fasteners
If the fasteners for the common rail pressure sensor (RPS) and high-pressure pump fuel metering unit (FMU) wiring on the engine are loose, wire movement during engine operation causes wear on the metal pins of the connectors attached to the sensor and metering unit. If the amount of wear increases and the contact between the metal pins of the connectors lifts occasionally while the engine is running, the ECU registers this as an open circuit, displays a fault code and restricts engine power; for the sake of safety, the high-pressure pump maintains the maximum amount of fuel delivery to the common rail without any control of the amount of fuel by the ECU; and in the common rail, the pressure adjustment valve opens and is permanently damaged due to excessive pressure, causing large amounts of fuel to be returned to the fuel tank. Make sure that the various wires remain connected firmly during engine delivery.

4. General Inspections

4.1. Precautions for General Inspections

- Before performing an inspection, disconnect the cable (ground cable) from the negative (-) battery terminal in order to prevent cable damage due to short circuits.
- Place a cover over disassembled parts to avoid any external damage or contamination by foreign materials.
- There is a danger of the painted surfaces of parts being damaged if contaminated by engine oil or antifreeze so they must be handled with care.
- When servicing parts which require special tools, damage to parts can generally be prevented by using the appropriate tools or special tools.
- Make sure to use genuine HD Hyundai Infracore parts for replacements.
- Do not reuse consumable parts which have already been used during inspections, such as copper seal rings, gaskets, O-rings, oil seals, lock washers, self-locking nuts, and rubber seal rings. Be sure to replace them with new parts, while keeping disassembled parts sorted into groups to make reassembly easier.
- The tightening bolts and nuts for each part were designed with their mounting location in mind and each have a different strength and length, so they must be assembled in the correct locations.
- Be sure to clean parts before inspecting or reassembling them.
Also, clean out oil holes, etc. using compressed air in order to prevent contamination due to foreign materials.
- Before assembly, apply a thin layer of clean oil or grease to the sliding and moving areas of parts in order to lubricate them.
- If necessary, use sealant on gaskets in order to prevent oil and water leaks.
- When tightening bolts and nuts, be sure to observe the specified tightening torque.
- When the inspection is complete, perform a final inspection to ensure that the inspection was performed properly.

4.2. Daily and Regular Inspections

General inspections refer to preventative maintenance. By performing maintenance in advance before problems occur in the engine, the user can keep the engine running in an optimal state and make use of the engine without any malfunctions for an extended period of time.

Preventative maintenance performed in order to prevent engine malfunction and constantly maintain optimal performance requires daily and regular inspections, as well as basic maintenance.

- The daily inspection items in the following table should be checked daily (Daily inspections)
- The regular inspection items below must be checked thoroughly at regular intervals. (Regular inspections)

Inspection Items		Daily	Regular inspection (at every interval of hours)						Remarks
			50	100	250	500	600	1,000	
Cooling system	Check coolant level and refill	●							
	Check coolant and antifreeze for contamination					●		Replace every year	
	Clean heat exchanger and fresh water cooling circuit							1,200 hours	
	Check belt tension and replace	●						Note)	
	Replace the thermostat							Replace every two years	
	Check saltwater discharge rate (Check opening of Kingston valve)	●							
	Check impeller and CAM					●			
Lubrication system	Check oil level in oil pan/ reduction gear	●							
	Replace engine oil		● Initial			●		CI-4	
	Replace the oil filter		● Initial			●			
	Replace oil in reduction gear			● Initial			●		
	Check cylinder compression pressure							●	
Intake and Exhaust system	Adjust the intake/exhaust valve clearance		● Initial			●			
	Clean intercooler						●		
	Air cleaner							400 hours	
	Check concentration of exhaust gas	●							
Fuel system	Inspect for leaks in fuel line	●							
	Remove residue from fuel tank (Clean the fuel tank)							When necessary	
	Drain water from oil-water separator	●							
	Replace the primary & secondary fuel filter cartridge					●		250 hours when biodiesel is used	
Electrical system	Check warning lamp	●							
	Check battery charging state	●							
	Check wiring						●		

* If the sulfur content of the fuel exceeds 0.5%, reduce the replacement and inspection intervals by half.

Note) Replace when tensioner pointer enters the horizontal range.

4.3. Cooling System

4.3.1. Checking and refilling coolant

- Check the coolant level daily and add more if necessary. Also, coolant should be changed every 1,200 operating hours or 6 months (whichever occurs first). If coolant is contaminated, it can lead to engine overheating and overflow into the thermal expansion tank.
- Be sure to use clean water (soft water) such as tap water for the coolant used in the engine.
- Mix 45% antifreeze and 5% or less of an anti-corrosive agent into the engine coolant.
(Refer to "Checking Coolant")



CAUTION

A suitable ratio of antifreeze and anti-corrosive agent prevents corrosion effectively in order to keep the engine running safely, but an unsuitable mixture causes cavitation, etc. in the coolant pump impeller and coolant passages within the block, leading to engine failure.

1) Adding coolant

Fill the reservoir tank 2/3 with coolant. At this time, loosen the screws on the raised coolant lines or plug on top of the wet turbocharger in order to release air, then retighten them when no more air bubbles are visible.

Coolant must be poured in slowly to avoid air mixing with the coolant.

After adding coolant, idle the engine for around five minutes to circulate the coolant containing air, causing the air to be released and lowering the coolant level. At this time, stop the engine and add more coolant.

2) Replacing coolant

- Open the coolant filler pressure cap to remove the pressure.
- Remove the two plugs from the bottom of the heat exchanger and the coolant suction pipe to drain the coolant.
- Tighten the coolant drain plug.
- Add more coolant according to the "Adding Coolant" section above.

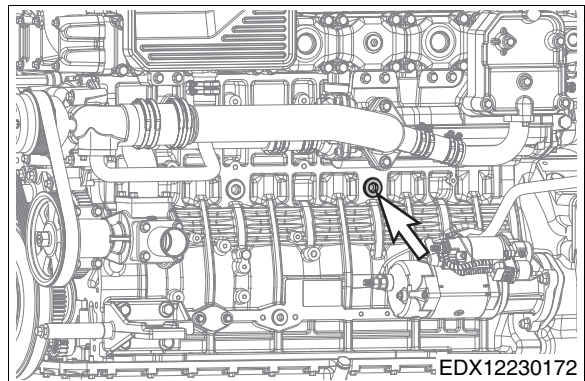

CAUTION

When removing the coolant pressure cap while the engine is hot, wrap the cap in a cloth and loosen it slowly to release steam inside. The steam can cause burns if the coolant pressure cap is opened suddenly.

4.3.2. Checking coolant and antifreeze for contamination

1) Coolant Inspections

- Engine coolant is a mixture of clean water (soft water) such as tap water with 45% antifreeze and 5% anticorrosive agent added. The mixture concentration of antifreeze and anti-corrosive agent must be inspected every 600 hours in order to keep it at a suitable level.
- The mixture concentration of antifreeze and anti-corrosive agent can be checked with a coolant contamination measuring kit.
(Fleetguard CC2602M : DHI No. ; 60.99901-0038)
- How to use the coolant contamination measuring kit
 - a) Collect coolant between 10 - 55 °C from the drain plug on the engine cylinder block or the pipe at the coolant pump inlet and fill the plastic container around halfway.



CAUTION

When gathering a coolant sample, the coolant in the reservoir tank is less contaminated and may not yield an accurate measurement of the concentration in the engine, so gather a sample of coolant from the bottom of the cylinder block.

- b) After shaking the coolant sample, dip the test strip in the container, take it out after 3 to 5 seconds, then shake the moisture off the test strip.
- c) After waiting approx. 45 seconds for the colors on the test strip to change, compare the discolored test strip with the figures at the horizontal and vertical intersections on the color list label attached to the storage container for the test strip in order to determine whether the concentration and level of contamination are safe.



CAUTION

The color of the test strip may change 75 seconds after being taken out of the coolant so compare the colors and perform the inspection quickly within 75 seconds. Do not touch the colored area by hand.

- Reading the test strip



- a) Compare the FREEZEPOINT (freezing point) at the top of the storage container with the changed color on the pink end of the test strip to determine the antifreeze concentration. (The concentration must be within 33 - 50% of the color range.)
- b) Compare the discoloration on the middle and first part of the test strip with the horizontal and vertical color indications on the container. The point where they intersect indicates the state of the anti-corrosive additive. It should be maintained within the green section of 0.3 - 0.8, a suitable range.
- c) If the measured result from section (b) above is less than 0.3, add more of the anti-corrosive additive. If it is over 0.8, drain some of the coolant and add soft water to adjust the concentration.

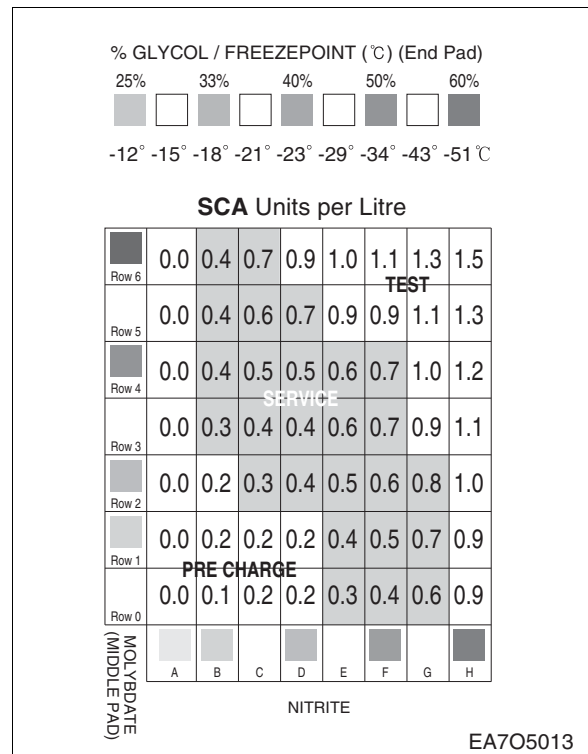



CAUTION

In order to prevent corrosion within the cooling system in the engine, drain the coolant every year or every 2,000 hours (whichever occurs first) and replace it with fresh coolant.

2) Antifreeze

It is recommended to mix coolant with 45% antifreeze. Antifreeze can prevent freezing and corrosion of the cooling system and increase the boiling point of coolant. The amount of antifreeze in winter can be adjusted according to the ambient temperature as shown in the following table.

Each freezing point by antifreeze ratio in the table differs slightly depending on the type of antifreeze. For details, refer to the specifications provided by the antifreeze manufacturer.

Ambient temperature (°C)	Coolant (%)	Antifreeze
-10 or more	85	15
-10	80	20
-15	73	27
-20	67	33
-25	60	40
-30	56	44
-40	50	50

The amount of coolant decreases naturally as the engine is operated. Adding tap water in this state can reduce the antifreeze ratio in the coolant. To maintain the specified ratio (45%), check the ratio and add the necessary amount of antifreeze.

4.3.3. Cleaning the heat exchanger and fresh water cooling circuit

1) Cleaning the heat exchanger

If the tubes in the heat exchanger are clogged by small particles or corrosion, the amount of saltwater supplied decreases, causing the coolant to overheat and gradually reducing the cooling efficiency.

- Remove the covers on both sides of the heat exchanger and clean the tubes in the heat exchanger of any small particles clogging them.
- When cleaning the heat exchanger tubes, remove any rust from the outside and inside of the tubes using a small wire brush, then spray them with pressurized water to clean them thoroughly.

2) Cleaning the fresh water cooling circuit

Cooling efficiency drops when the inside of the cooling circuit is contaminated with corrosive scale or sludge particles, etc.

Perform periodic inspections and clean the inside of the cooling circuit with a cleaning agent if necessary.



Cleaning interval for heat exchanger and cooling circuit : every 1,200 hours.

The cleaning interval must be adjusted to suit the operating environment.



Note :

To prevent corrosion of the cooling system, a plug screw type Zinc Anode is applied, and please check it regularly (1 month) and replace it when it is corroded.

4.3.4. Inspecting the Micro-V Belt tension and replacing the belt

The belt is equipped with an auto tensioner which automatically adjusts the belt tension so there is no need for extra adjustment of the tension.

During daily inspections, be sure to inspect whether the pointer on the auto tensioner is indicating that it is time for a replacement, as well as whether there is any damage to the belt due to external factors.

1) Replacing the Micro-V Belt if necessary

Replace the belt set in the event that the pointer on the auto tensioner indicates that it is time for a replacement, or in cases where damage to the belt from external factors has been confirmed and there are concerns of severe damage occurring.

2) Inspecting the Condition

Inspect the Micro V-belt for cracks, oil, overheating and wear.

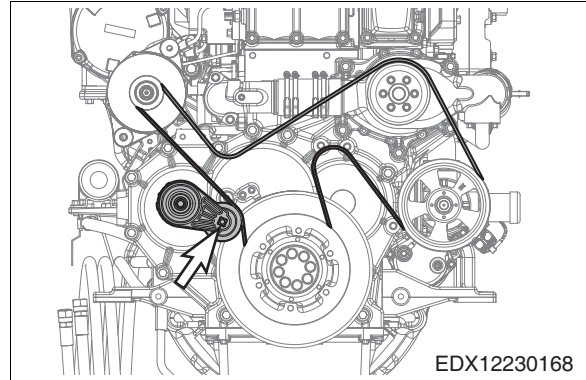

The vertical rod (A) shown by the arrow is the "pointer," and the belt replacement period is indicated when this "pointer" enters the horizontal (B) range shown in orange.

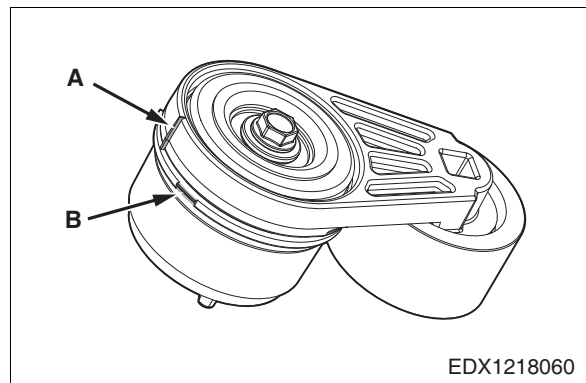

3) Measuring Tension

The belt is equipped with an auto tensioner which automatically adjusts the belt tension so there is no need for extra measurement of the tension. However, in the event that measuring tension is deemed necessary, measure the tension as follows.

- Lower the indicator arm (1) to within the scale.
 - a) Mount the tester on the belt between the two pulleys so that the edge of the contact surface (2) is at the same height as the V-belt.

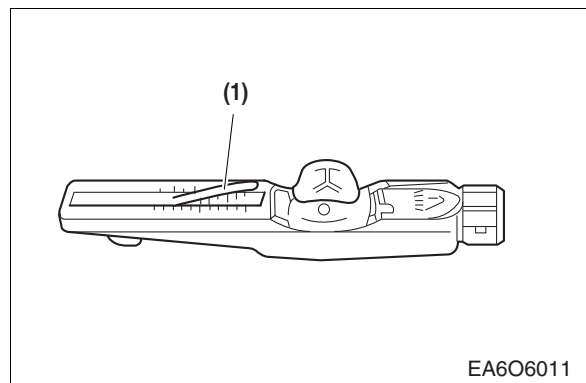

- b) Press down on the pad (3) slowly until the sound of the spring being released is heard. Then, the indicator moves upwards. If pressure is maintained even after the spring is released, you will not obtain an accurate reading.

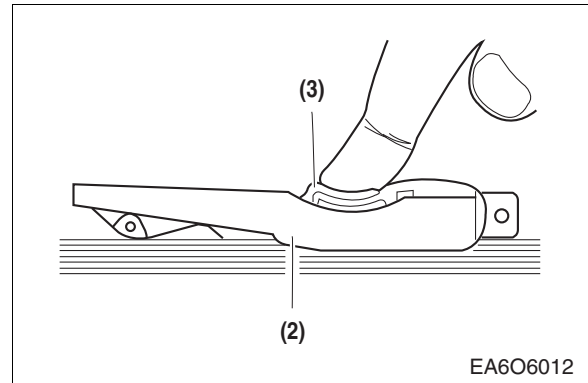

- Reading the Tension Value
 - a) Read the tension of the belt at the point where the top surface of the indicator arm (1) intersects with the scale.
 - b) Before reading the value, check whether the indicator arm is remaining in place.

Type	Drive belt width	Tension on the tester		
		Newly installed		During service after prolonged operation (replacement interval)
		Installation	10 minutes after operation	
8PK Micro V	27.61 mm	450 ~ 650 N	450 ~ 650 N	300 N

4) Adjusting tension and replacing the Micro-V Belt

- Use the square groove located at the top of the pulley on the auto tensioner to rotate the auto tensioner clockwise.
- Remove the existing belt.
- After fitting all of the pulleys (except the auto tensioner's) with a new belt, rotate the auto tensioner clockwise one last time to wind the belt onto the auto tensioner pulley, then release the auto tensioner which was being pulled in the clockwise direction.

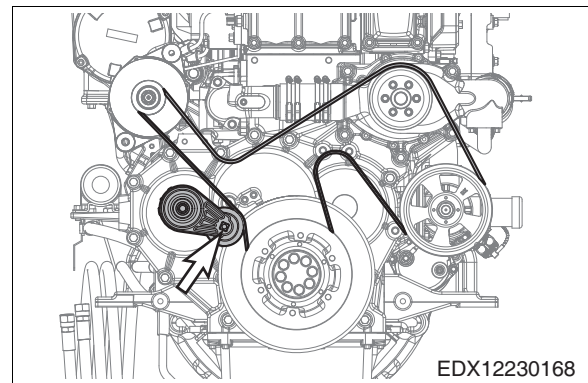

4.3.5. Thermostat

The thermostat keeps the temperature of the engine coolant between 79 - 94 °C, thereby preventing premature wear and heat loss in the cylinders.

When the temperature of the coolant reaching the thermostat inlet from the cylinder head is less than 79 °C, the valve is closed, bypassing the coolant directly to the coolant pump. When the temperature is 79 - 94 °C, the coolant, heated by the open valve, passes through the heat exchanger and is cooled.

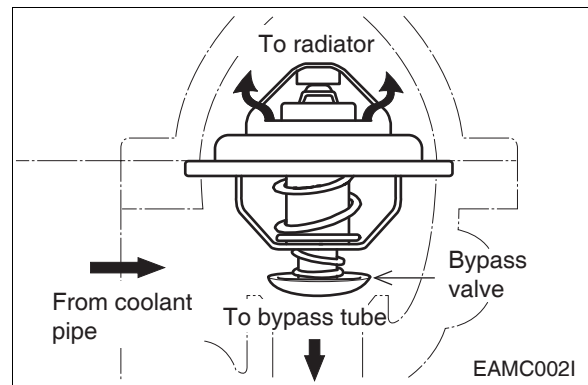

Item	Specifications
Type	Wax pellet type
Opening temperature	79 °C (185 °F)
Full opening temp.	94 °C (185 °F)
Valve lift	8 mm or higher

1) Inspection

- Check the wax pellet and spring for damage.
- Submerge the thermostat in a container filled with water, heat the container, and check whether the valve lift is 0.1 mm at 79°C and 8 mm or higher at 94°C.

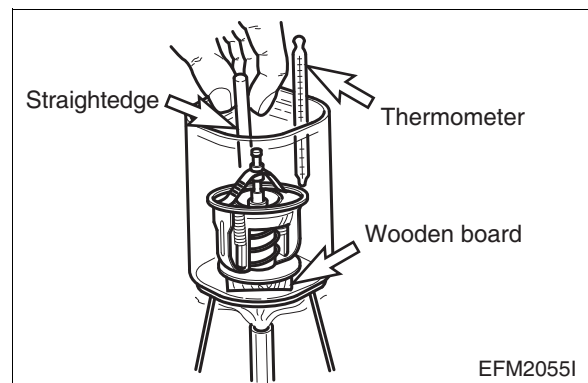

2) Cautions for replacing and handling thermostat

● Cautions for handling

Wax pellet-type thermostats have a slow reaction time to changes in coolant temperature, meaning that the valve does not open quickly. Thus, avoid overspeeding or operating under an excessive load after starting the engine initially.

- When draining and then refilling water in the engine cooling system, ensure that the air in the entire cooling circuit is discharged sufficiently.
- Replace the thermostat
Replace the thermostat if a defect is discovered. There may be a slight difference depending on the level of contamination of the engine coolant, but it is usually replaced every two years.

4.3.6. Checking the rubber impeller in the saltwater pump

The saltwater pump is driven by belt and employs a rubber impeller. Every time the engine is started, be sure to check that the Kingston valve installed at the bottom of the ship is open. If the valve is closed and the impeller rotates for over 20 seconds in a dry state without any saltwater, the rubber impeller can be burnt and cracked even in a short span of time since the frictional heat produced by the high rpm is not cooled, thereby damaging the rubber fins.

1) Disassembling the rubber impeller

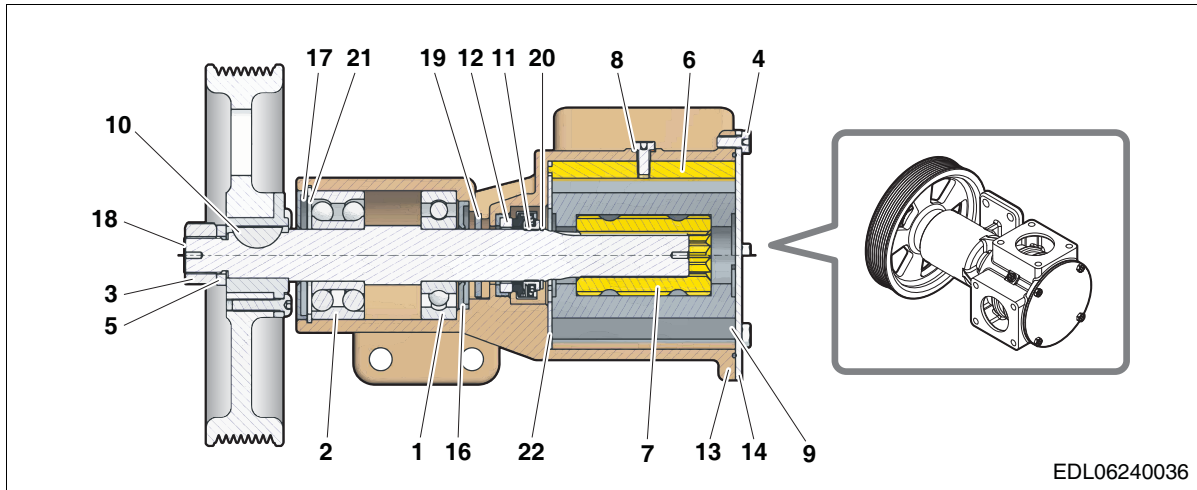

1. Bearing	7. Cover	13. O-ring	19. Sleeve
2. Bearing	8. Gasket	14. Pump casing	20. Snap ring
3. Nut	9. Impeller	15. Pulley	21. Snap ring
4. Screw	10. W/R key	16. Oil Seal	22. Plate
5. Spring washer	11. Carbon	17. Oil Seal	
6. Cam	12. Ceramic	18. Shaft	

- Loosen the screw on the rear cover and remove the O-ring.
- Insert two flathead screwdrivers without sharp tips as shown in the picture above on the left, using them as a lever to remove the impeller, or grab the body of the impeller firmly with pliers and turn it to the right to remove it.
- Loosen the cam mounting screw on the outer surface of the housing and remove the cam.
- Remove the wear plate inside the impeller.

2) Assembling the rubber impeller

- To prevent the dowel pins and wear plate mounted inside the impeller from rotating, align them with the circle of holes. However, check the amount of wear and replace it with a new one if excessively worn.
- In order to prevent water leaks and corrosion, apply sealant to the screw at the top of the cam and the cam mounting screw, then assemble it.
- Apply a thin layer of grease to the shaft mounting section on the inner side and outer surface of the impeller, then turn it to the right with the impeller inserted into the assembly shaft key and push it until it makes complete contact with the inner wear plate.
- In the case of impeller, it is recommended to replace it every 6 months to 1 year depending on aging due to the nature of the rubber product.



CAUTION

Make sure that the impeller makes contact with the inner wear plate. Please note that using a hammer to force the impeller into place may cause the shaft to move and damage the internal mechanical seal, resulting in leaks.

- Mount the O-ring and then assemble the rear cover.
- After opening the Kingston valve once the final assembly is complete, loosen the plug screw on the top of the saltwater pump to bleed the system, check for any leaks, then start the engine.

4.4. Lubrication System

4.4.1. Check the oil level

- Check the oil level in the oil pan and reduction gear daily using the oil dipstick.
- The oil level must be measured approx. 10 minutes after stopping the engine when the hull is in a horizontal state.
- Check the oil smeared on the oil dipstick, inspect the viscosity and state of contamination, and change the engine oil if necessary.

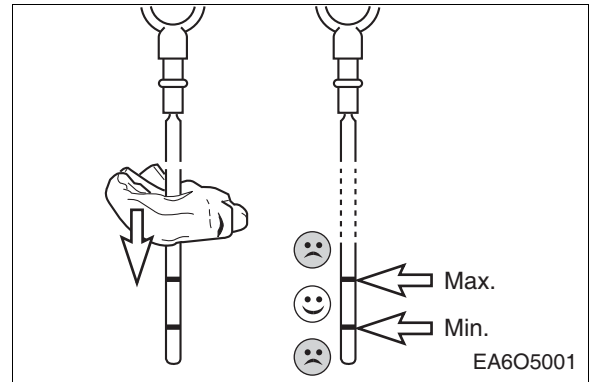

CAUTION

Overfilling oil past the upper limit indicated on the oil dipstick reduces the engine power and increases the amount of blow-by gas, leading to engine failure.

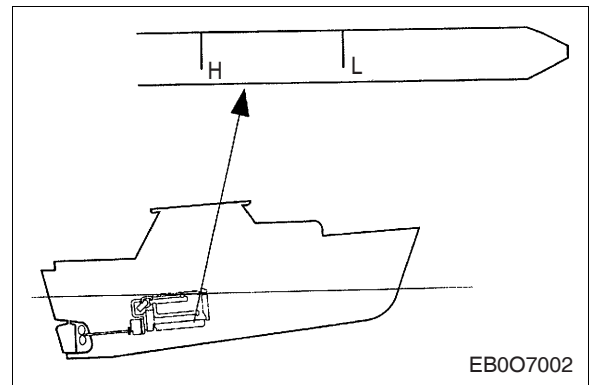

- Re-engraving marks on the oil dipstick
Upon release from the factory, the oil dipstick (for the oil pan) has upper and lower limit lines engraved when installed horizontally. When running the engine initially, check the installation angle of the engine mounted in the ship. If the angle exceeds 6° , recheck the engravings and if necessary, re-engrave the upper and lower limit lines on the dipstick as shown in the picture on the right to suit the inclination of the engine in the hull based on the max./ min. oil capacity of the engine.
(Refer to "1.1. Engine Specifications" for the max./min. oil capacity)

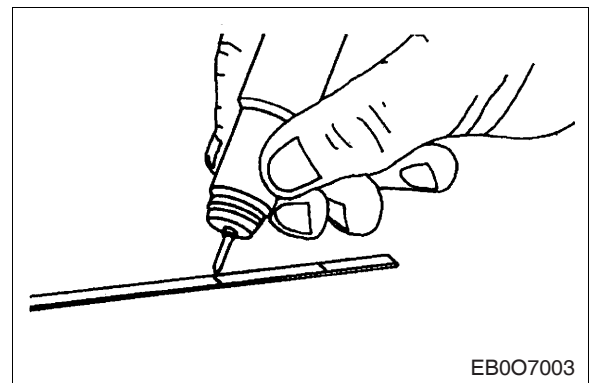

4.4.2. Replacing the engine oil

The engine oil and oil filter are important factors affecting the engine life.

Engine oil affects startability, fuel consumption, carbon deposits in the combustion chamber, and wear to the cylinder liner, etc.

Replace the engine oil after every 500 hours of operation.

In addition, the oil filter and engine oil must be replaced after the initial 50-hour break-in period.

Replacement method

- Run the engine until it reaches the normal operating temperature. When the engine oil is warm, turn the drain pump to drain the oil in the oil pan (as well as the oil in the reduction gear, if necessary). Draining the engine oil while it is warm allows the oil to be drained more thoroughly, and impurities accumulated in the oil pan are also discharged along with the oil.

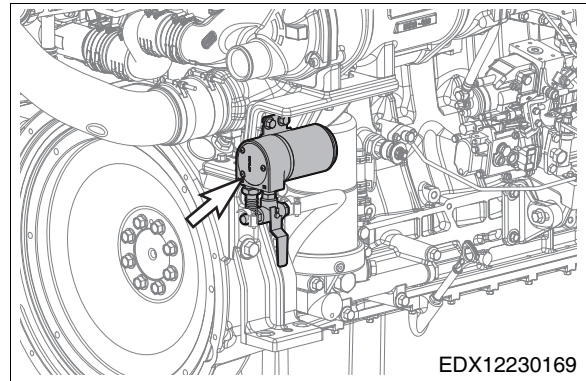

- Open the oil filler cap on the head cover and refill the engine oil to the appropriate level.
- While adding oil, be careful not to let dust or foreign materials enter the system. Check whether the oil level is near the maximum level mark on the oil dipstick.
- Idle the engine for approx. five minutes so that oil is distributed throughout the lubrication circuit.
- Then, stop the engine. Wait approx. 10 minutes, then check the oil level. Add more oil if necessary.

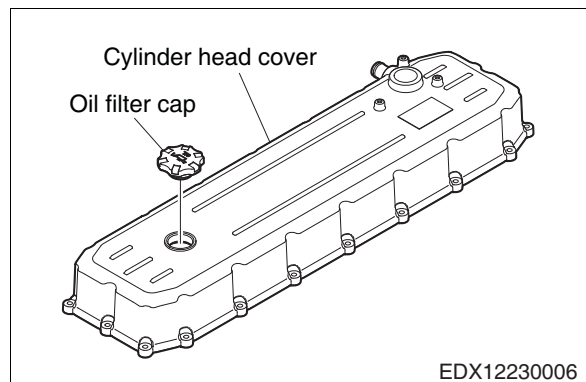

Recommended lubricant

Upon initial release from the factory, the engine is filled with API grade CJ-4 high-quality oil for engine break-in.

This oil should only be used during the initial 50 hours of engine break-in. Then, replace it with new oil. Be sure to check the oil level frequently during the break-in period. It is normal for the oil consumption rate to be higher than usual until the piston rings are properly seated.

When checking the oil level approx. 10 minutes after stopping the engine, the oil level must always remain between the upper and lower limit marks on the oil dipstick.

Use API grade CI-4 or higher and SAE 10W40 engine oil in order to obtain the maximum engine performance and lifespan. Refer to the label printed on the container of the product.

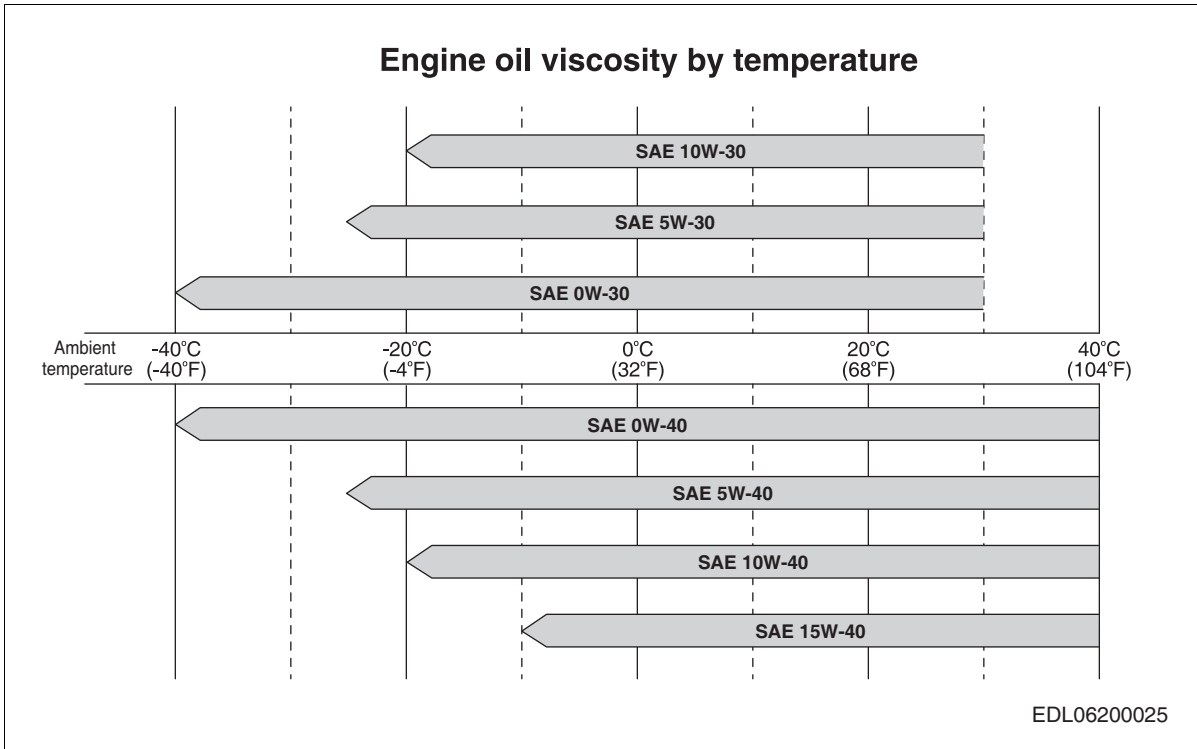

● Recommended oil specifications

Manufacturer	Recommended oil	Grade
SK	SK ZIC X5000 DS 10W-40	Grade CI-4 10W40
GS Caltex	Kixx DX EURO CJ4 10W40 / GS Caltex	
STLC	RUBIA TIR 7400	

* Grade CI-4 must be replaced every 500 hours, while grade CH-4 must be replaced every 250 hours.

4.4.3. Replacing the oil filter cartridge

Both engine oil and the oil filter are important factors affecting the engine life. Replace the oil filter cartridge as well when replacing the oil.



CAUTION

Do not forget to retighten the drain plug after draining the engine oil.

- Use a filter wrench to turn and loosen the oil filter in the counterclockwise direction.
- Wipe the filter and body of the packing contact surface on the oil filter with a rag thoroughly to ensure that the new filter cartridge can be seated and sealed properly.

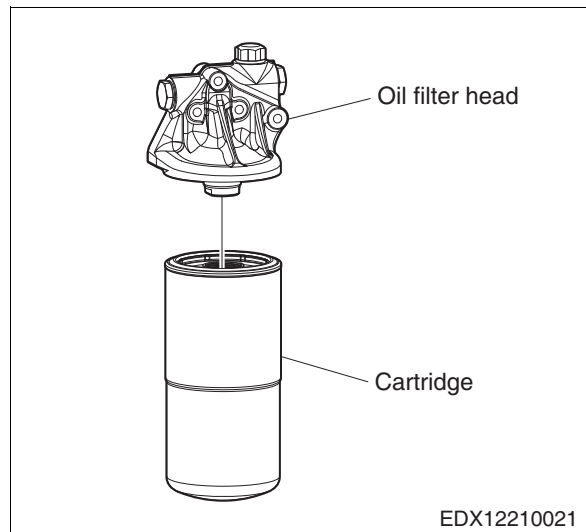



CAUTION

When replacing the oil filter cartridge, make sure to use a genuine new HD Hyundai Infracore cartridge.

- Before installing the new cartridge, apply a thin layer of clean engine oil to the O-ring, then tighten it until the sealing surface makes contact with the O-ring and turn it an additional 3/4 to one turn in order to create an airtight seal.

4.4.4. Replacing the oil in the reduction gear

Always use SAE 30 oil (not multi-grade oil) in the reduction gear, regardless of the season. The oil in the reduction gear must be replaced after the initial 100 hours of engine operation, then every 600 hours afterwards.

4.4.5. Cylinder Compression Pressure

- After performing a test run of the engine, stop the engine and disassemble the nozzle assembly.
- Install a special tool (gauge adapter) in the nozzle holder mounting hole on the cylinder and connect the compression pressure gauge to the adapter on the opposite side.
- After shutting off the fuel circuit, run the starter motor and measure the compression pressure sequentially in each cylinder.

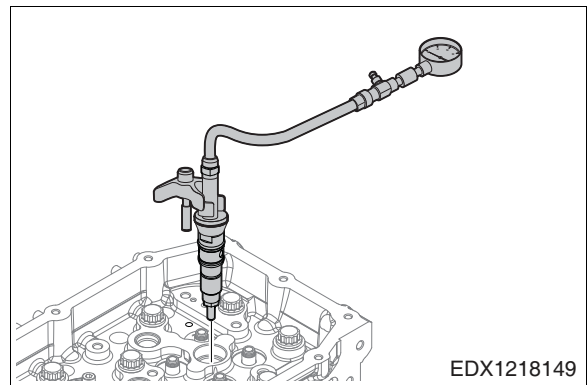

Model	Standard
DX12	35 bar

Test conditions : Coolant temperature of 20°C and speed of 200 rpm (approx. 10 rotations)

4.5. Intake and Exhaust System

4.5.1. Adjust the intake/exhaust valve clearance

The valve clearance must generally be inspected after every 1,000 hours of engine operation.

For details, refer to the "Valve Clearance Adjustment Procedure" contained in "6.3.21. Cylinder Head."



CAUTION

The valve clearance must be adjusted in the following cases.

- When servicing internal engine parts (pistons, rings, etc.) or disassembling the cylinder head
- When severe abnormal noise is coming from the valves
- When there is an excessive amount of exhaust gas or the engine is not running properly in spite of there being no problems in the fuel system.

4.5.2. Cleaning and replacing the air filter element

The engine life and performance are affected significantly by the quality of the intake air. A contaminated air filter element reduces the amount of intake air affecting the engine power, leading to premature engine failure.

Furthermore, a damaged air filter accumulates foreign materials in the cylinder components or valves, causing uneven valve operation and wear to the pistons and liner.

This increases oil consumption, reduces engine power and ultimately shortens the engine life. Hence, the air filter element must be cleaned and replaced periodically.

- Air filter element cleaning : Every 100 hours
- Air filter element replacement : Every 400 hours

1) Cleaning the element

Clean the element in warm water and a foam-less detergent.

Rinse the element in clean water.

Air-dry it naturally or dry it thoroughly using an electric fan. Using a flame or compressed air to dry the element can damage it.

2) Inspecting the element

Check whether the inside of the element is clean and dry.

Replace the element with a new one if it is torn or damaged.

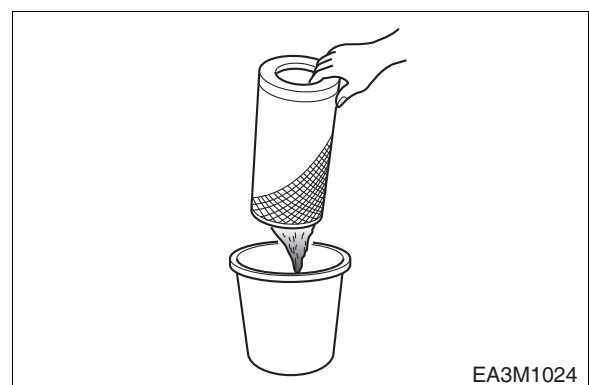
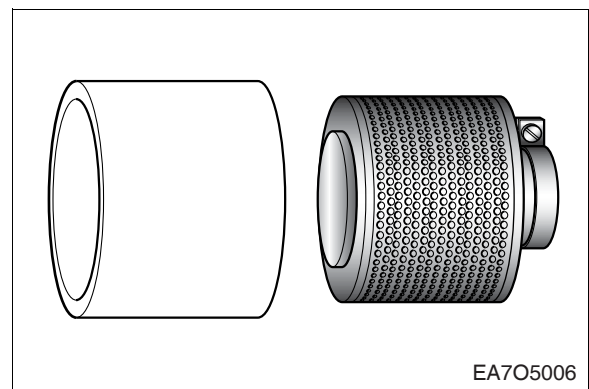

4.5.3. Cleaning the intercooler

The intercooler installed in the DX12 model is a saltwater cooling-type intercooler whose lifespan and performance are affected significantly by the quality of the intake air.

Contaminated, dirty air contaminates and clogs the air fins in the intercooler, reducing engine power and ultimately causing engine failure. Hence, the air filter element must be inspected daily and always kept clean.

The anode must be replaced periodically in order to prevent corrosion of the tubes in the intercooler.

The replacement interval may vary depending on the engine operating conditions and saltwater quality so perform inspections and replacements according to the operating conditions.

<Cleaning the intercooler>

Regular cleaning is required in order to maintain the maximum efficiency of the intercooler.

To clean the intercooler, remove the cover and clean it in a hot alkaline solution, i.e. a 3 - 5% P3-FD solution.

If there are hard deposits of scale stuck to the intercooler even after doing so, pour a solvent on it which is capable of removing scale without corroding the intercooler fan. Repeat this until the deposits are removed. When reassembling the intercooler, use a new O-ring, and before installing the O-ring, check to make sure that the contact surface is clean.

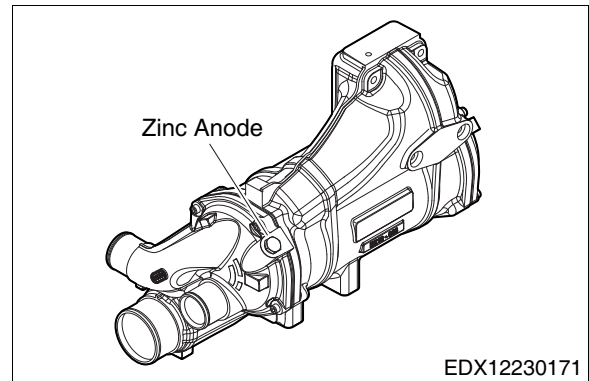

Intercooler cleaning : Every 1,000 hours



Note :

To prevent corrosion of the cooling system, a plug screw type Zinc Anode is applied, and please check it regularly (1 month) and replace it when it is corroded.

4.5.4. Checking the concentration of exhaust gas

Exhaust gas being discharged from the engine's exhaust pipe means that combustion is occurring within the engine. Observe the state of exhaust gas daily. If abnormal exhaust is discharged (excessive exhaust gas, white smoke, black smoke, etc.), there is a problem with the engine combustion. This requires a professional inspection or maintenance.

4.6. Fuel System

- The common rail fuel injection system operates at high pressures (1,800 bar). Accordingly, the system must be handled and serviced with care, and the safety regulations must always be followed.
- The common rail fuel injection system should never be removed, installed or inspected while the engine is running or immediately after stopping the engine; inspections and service work should be performed at least 30 seconds to one minute after stopping the engine.
- During service work and inspections, make sure that the workspace is clean before performing any work to prevent foreign matter from entering the fuel system; keep any unnecessary removal and installation to a minimum; and in the case of parts which must be reused during removal and installation, take the necessary measures to prevent foreign matter from entering the parts after removing them and clean them before reusing them for installation.
- The normal performance of O-rings and sealing washers used on high-pressure fuel pipes and in the fuel system cannot be guaranteed if they are reused; make sure to use new parts.
- When assembling high-pressure fuel pump, common rails, injectors, and high-pressure fuel pipes, take care to prevent damage due to impacts, etc. resulting from carelessness and make sure to assemble them precisely.

4.6.1. Fuel Tank

The fuel tank must be able to store fuel cleanly and safely and must be structured to satisfy the following requirements so as not to affect the components of the engine injection system.

- **Material**
Zinc (Zn), copper (Cu), lead (Pb), sodium (Na) and calcium (Ca) cause chemical reactions with water in fuel and biodiesel, thereby forming various corrosive acids, sludge and viscous substances. When this occurs, it causes premature clogging of the primary fuel filter, seizure of injectors, corrosion and wear of fuel system components, including the injection system, leading to excessive maintenance expenses resulting from engine failure. Hence, when the use of these materials cannot be avoided, make sure to apply a phosphate film or trivalent chromium plating to prevent the materials from coming into direct contact with fuel.
- **Air Intake/Discharge System**
When fuel is delivered to the engine, a reduction in pressure equivalent to the volume occupied by the fuel in the tank occurs, leading to a fluctuation in the volume of fuel as a result of a change in the fuel temperature. Hence, if the fuel tank is an enclosed structure, excessive static/negative pressure is formed, causing abnormal engine operation. Accordingly, the fuel tank must be equipped with an air intake/discharge system to constantly maintain atmospheric pressure, while the ports through which air is drawn in or discharged must be connected by means of extension hoses or tubes to a clean environment with minimal dust, moisture, insects, etc. or a suitable air filter must be installed to prevent such foreign matter from entering the system. When air inlets and outlets are installed in extremely dusty or humid areas, the service life of the primary and secondary fuel filters is severely reduced, while wear and corrosion of injection system components are accelerated, resulting in a shortened service life and excessive maintenance expenses.
- **Port for Draining Condensate and Cleaning Foreign Matter**
Inside the fuel tank, foreign matter entering through the air inlet and outlet ports as well as condensate on the inner wall of the tank resulting from the difference in temperature between fuel and ambient air form deposits continuously. The fuel tank must be equipped with a cleaning port for periodically removing and cleaning condensate and foreign matter to prevent foreign matter and condensate deposits in the tank from entering the engine fuel system.
- **Cleaning and maintaining the fuel tank**
After filling the tank with the recommended fuel, draining any condensation accumulated on the bottom of the tank completely and keeping the fuel full help to enhance engine performance.



CAUTION

Check whether the fuel supply valve is open. (If used)

As the fuel tank cools after stopping the engine, condensation forms and can contaminate the fuel. In order to prevent this, add fuel to the tank after running the engine each day.

In maritime regions, most fuel contamination is caused by moisture and the reproduction of microorganisms. Generally, contamination arises from handling fuel improperly and not following common sense. If fuel contains moisture, it is easy for microorganisms to reproduce and coat the bottom of the tank in a black slime. Hence, it is important to keep the amount of moisture in the fuel storage tank to a minimum.

In order to remove contaminated fuel from the fuel tank, install a water separator to gather the moisture and foreign materials in the tank. Drain the contaminated, foreign matter accumulated here every day and change the engine fuel filter several times until the fuel system is clean.

4.6.2. Fuel Requirements

Allowable Fuel Under Warranty

- 1) Korea: Article 115 Schedule 33 "Ultra Low Sulfur Diesel" of the Clean Air Conservation Act
- 2) Europe: EN590:2013 AC:2014, EN16734:2016
- 3) North America: ASTM D975-15C Grade 1D or 2D
- 4) Japan: JIS K2204:2007 (lubricity $\leq 520 \mu\text{m}$, FAME Max. 5%)
- 5) China: GB252:2015 and GB19147:2013
- 6) India: IS 1460 2005 Amm. 10 BS III or BS IV
- 7) Brazil: ANP69/2014
- 8) Russia: GOST R32511-2013 (excluding Articles 3 and 4)

● HVO (Hydro treated Vegetable Oil)

HVO is a synthetic diesel which is manufactured through the hydrogenation of plants and animal fats.

To the user, HVO is reminiscent of diesel in accordance with EN590, apart from HVO having a somewhat lower density.

HD Hyundai Infracore approves the use of up to 100% HVO for engines in accordance with the EU standard EN15940.

● GTL (Gas To Liquids)

GTL is a synthetic fuel that is often refined from natural gas. To the user, GTL is reminiscent of diesel in accordance with EN590, apart from GTL having a somewhat lower density and less odour.

HD Hyundai Infracore approves the use of up to 100% GTL in accordance with the EU standard EN15940.

4.6.3. Primary Fuel Filter

A primary fuel filter, two piping connecting adapters, and two fuel filter plugs are provided as separate accessories along with the engine.

Remove the plugs for preventing foreign matter from entering the fuel inlet/outlet of the primary fuel filter and tighten the connecting adapters provided to the specified torque.

(Specified adapter tightening torque: 5 ± 0.5 kg-m)

(Specified tightening torque for plugs: 2.25 ± 0.25 kg-m)

According to the installation location of the primary fuel filter, one connecting adapter per port in the both inlet/outlet ports is used, and the fuel filter plugs are assembled in the remaining ports.

When tightening the hose, hold the adapter with a spanner so that it does not turn together.

(Specified tightening torque for hoses: 7.0 ± 0.7 kg-m)

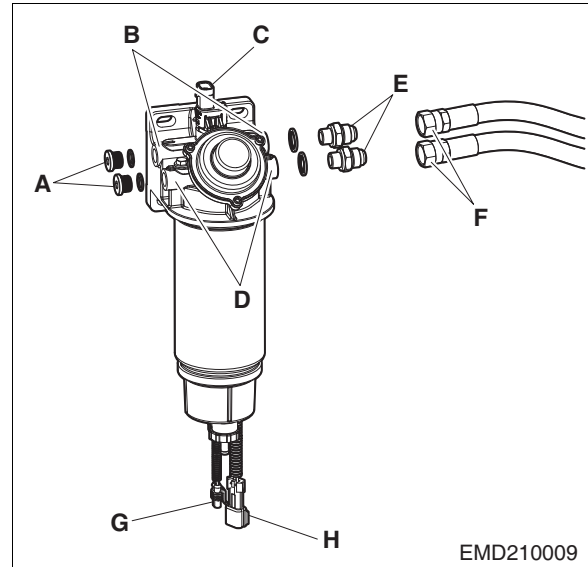

No.	Description
A	Fuel filter plug
B	Fuel inlet port
C	Fuel heater connector
D	Fuel outlet port
E	Fuel adapter SAE J516 37° CONE 7/8-14 UNF
F	Fuel hose
G	Water-in-fuel sensor connector
H	Fuel heater connector

- Fuel heater
 - Fuel heater specifications
 - Operating voltage: DC24V
 - Operating power: 200 W
 - Operating temperature: turns on at 7 ± 4 °C or less, turns off at 24 °C

- Water-in-fuel sensor
 - Water storage capacity of the primary fuel filter
 - Start of electrical connection with water in fuel sensor switch: 90 ml (0.06 gal.)
 - Maximum water capacity: 200 ml (0.13 gal.)
 - Water in fuel sensor switch specifications
 - Operating voltage: 5 VDC
 - Resistance: $82 \text{ k}\Omega \pm 2\%$ @ 25 °C

Primary Fuel Filter	Harness connecting part
15300002 (DELP HI)	15300027 (DELP HI)

Primary Fuel Filter	Harness connecting part
DEUTSCH DT04-2P	DEUTSCH DT06-2S

4.6.4. Replacing the Primary Fuel Filter

- Use a filter wrench to turn and loosen the fuel filter cartridge in the clockwise direction.
- Discard the used filter in the designated place.
- Clean the bowl with water, wipe it with a clean cloth, and let it dry.
- Wipe the head with a clean cloth. Make sure to remove impurities from the filter contact surface of the head in particular.
- Use a brush to apply a thin layer of engine oil to the O-ring.
- Mount the cartridge perpendicularly to the head screw thread.
- Once the O-ring is touching the sealing surface, turn the cartridge 3/4 to one turn in the counterclockwise direction to assemble it.
- Mount the bowl perpendicularly to the filter screw thread.
- Once the O-ring of the bowl makes contact with the sealing surface, assemble it by turning the O-ring clockwise by 3/4.
- Once the O-ring of the bowl makes contact with the sealing surface, assemble it by turning the O-ring clockwise by 3/4.

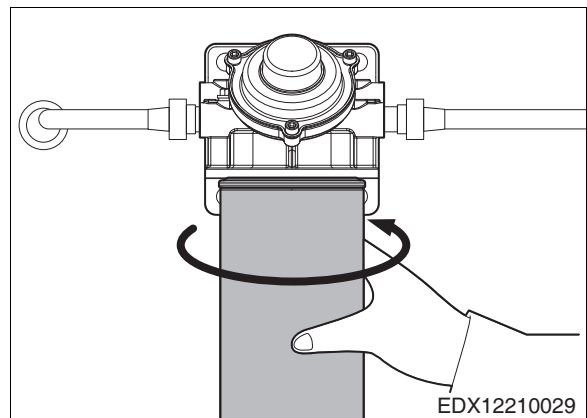
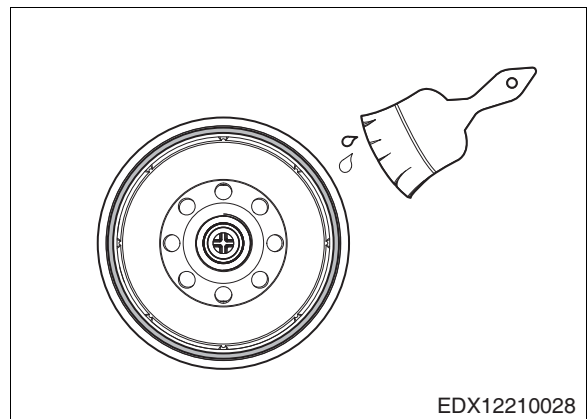
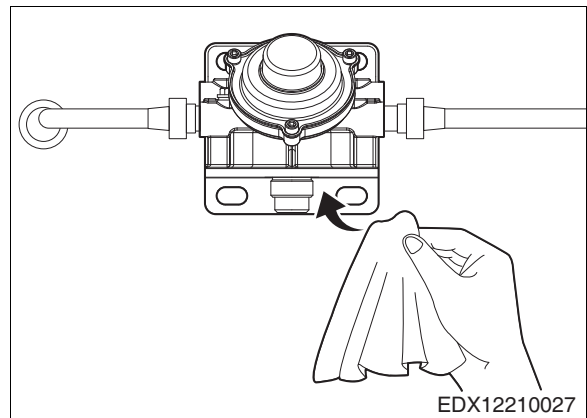
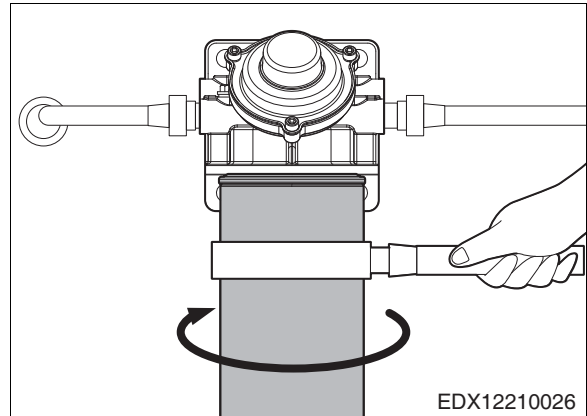

4.6.5. Fuel Filter

The fuel filter consists of a primary and secondary filter; the primary filter serves to filter out water and large particles of foreign matter, while the secondary filter is used to filter out smaller particles of foreign matter.

If you do not regularly inspect the fuel filter and discharge the water in the fuel filter, water enters the fuel system of the engine and can cause severe faults in the fuel injection pump, fuel injection pipe, common rail and injector. In addition, the fuel filter performance can be degraded or damaged.

- When draining the water in the fuel filter, fuel may also be drained as well. Fuel is a highly flammable substance. Hence, smoking or using an open flame near the engine may cause a fire.
- Only use clean fuel with the specified grade. Using imitation or unspecified fuel may increase the amount of water in the fuel filter.
- If you do not drain the water in the fuel filter when the fuel filter warning lamp is illuminated, water may enter the fuel system and cause the engine to turn off.
- New fuel filters must be assembled without any fuel in them. Do not use the fuel in replaced fuel filters or the fuel in the fuel tank in new fuel filters.

4.6.6. Replacing the fuel filter

- Turn the fuel filter cartridge counterclockwise with a filter wrench to loosen it. Discard the used filter in the designated place.
- Wipe the filter contact surface clean.
- Apply a thin layer of engine oil to the O-ring and add fuel to the new filter.
- Install the O-ring on the sealing surface and tighten the cartridge another 3/4 to one turn.

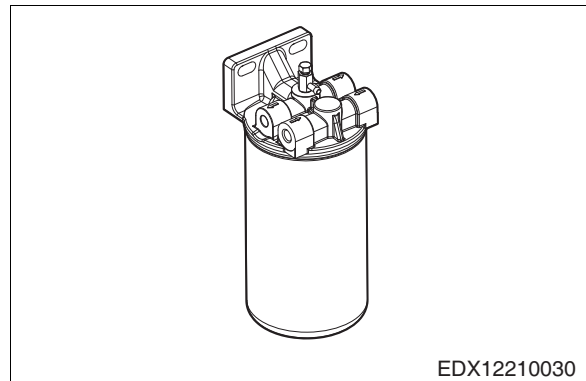

4.6.7. Bleeding the fuel system

Whenever the fuel filter is replaced or the engine stalls due to insufficient fuel, remove the air from the fuel line as follows.

Connect the hose to air bleeder port (A) of the secondary fuel filter; then, after unscrewing the fuel bleeder plug (B), operate the primary fuel filter's priming pump (C) to bleed the air.

- Continue until bubble-free fuel flows out of the air bleeder port.
- After all air has been eliminated, reassemble the secondary fuel filter's air bleeder plug and remove the hose connected to the port.

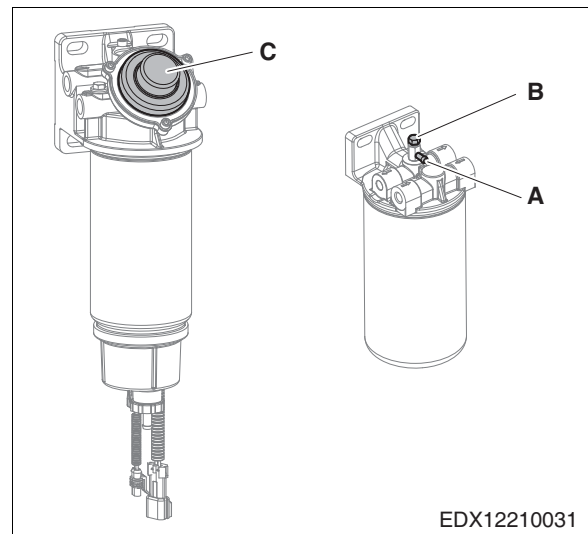

4.6.8. Fuel Lines Connected to the Engine

Since the fuel lines connecting the engine and the fuel tank must be flexible enough to withstand vibrations while the engine is running, it is recommended to use hoses.

Install it in the necessary location according to the location of the primary fuel filter and the fuel tank.

When additional fuel hoses of different lengths are required, use the fuel hose specifications provided to order hoses of the desired length from a hose supplier.

- Hose
SAE 100R1 AT Type I.D. \varnothing 12.7 mm,
O.D. max. \varnothing 21.5 mm
- Hose coupling
SAE J516 37° Flare, 7/8-14 UNF

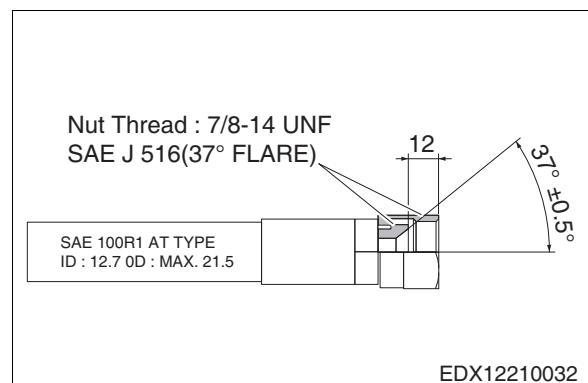

4.6.9. Engine Low-Pressure Fuel Lines

All low-pressure fuel lines are made of metal and have couplings which are shaped to fit the lines in order to maintain an airtight seal. When reused after repeated removal and reinstallation, the lines lose their airtightness and may cause fuel leaks. Low-pressure fuel lines may be reused only up to three times; then, they must be replaced with new ones. In the event that running the engine with a reused part is unavoidable, check for leaks periodically until the part can be replaced with a new one and make sure to replace the part as soon as possible.

When installing parts, tighten the union nuts and hollow screws using the specified tightening method, and make sure to hold the opposing parts in place with a tool while tightening parts to ensure that the tightening torque is applied only to the coupling joint.

When the engine is running, all fuel lines must remain secured firmly in the positions where they were installed upon release from the factory. Running the engine with a missing or loose fastener produces vibrations which may damage the fuel lines, so always make sure that parts are secured in their proper positions.

4.7. Electrical System

4.7.1. Checking the warning lamp

Pay careful attention to whether the lamp on the gauge panel malfunctions during daily use.

It is normal for the oil warning lamp to turn on before starting the engine.

4.7.2. Checking the battery charging state

Check whether the battery is discharged or damaged before using the engine.

4.7.3. Checking the wiring

Every 600 hours, be sure to check whether the electrical wiring connected to or in contact with the hull has come loose or whether there is any damage (open circuit, short circuit, etc.) in the wires themselves.

4.8. Long-Term Engine Storage and Maintenance

When storing the engine for an extended period of time, it must be stored and maintained properly in order to prevent contamination or corrosion in the parts. By doing so, one can expect even smoother engine operation than usual and a long service life free of malfunctions. The parts inside and outside the engine are particularly prone to rusting so be sure to maintain the engine as follows.

- Drain the coolant completely, pour in clean fresh water (soft water), run the engine until the internal coolant circuit is cleaned out sufficiently, then drain the coolant again. After doing so, add the specified coolant (mixed with 45% antifreeze).
- Run the engine until the coolant reaches the normal operating temperature of 79 - 94 °C, then stop the engine.
- Either turn and remove the drain plug on the oil pan or turn the drain pump to drain the lubricant, then replace the oil filter cartridge with a new one and add fresh oil up to the upper limit line. When draining oil, run the engine for around 10 - 15 minutes until it is hot, then stop it and drain the oil immediately in order to discharge the foreign matter sitting on the bottom of the oil pan.
- After completely tightening the fuel tank valve or cock, remove the fuel filter and oil-water separator and clean them or replace the element; then, tighten them enough to prevent leaks.
- Run the engine for approx. 5 minutes until clean fuel has been circulated sufficiently in the fuel line.
- Disassemble and thoroughly clean the air filter. If it is severely contaminated, replace the element with a new one.
- Drain the oil in the reduction gear completely, disassemble and clean the strainer inside the reduction gear, then add the specified oil (SAE #30, API grade CC or higher).
- Idle the engine for approx. 10 minutes while switching between neutral/ forward, neutral/ reverse to enable clean oil to be distributed throughout the inside of the engine.
- Place the engine's throttle lever in the "Idle" position and shut off the power (neutral or OFF) to the reduction gear and FPTO, etc.
- Drain the coolant completely and keep the drain plug removed.
- Close the valve on the saltwater pipe firmly. If the weather is exceptionally cold, open the drain plugs on the heat exchanger, air cooler (intercooler), reduction gear oil cooler, etc. to drain the saltwater completely, then leave the plugs removed on the engine components open. Also, be sure to remove the rubber impeller in the saltwater pump and store it in a shaded place.

- Disconnect the negative (-) battery cable first, then disconnect all the rest of the cables. After wiping the battery and cables clean, add distilled water to the battery. (If required)
- Clean each part thoroughly, apply grease to parts with a risk of rusting (moving parts, etc.), and spread wax on painted surfaces.
- Loosen the belts so that no force is applied to the bearings and insert thick pieces of cardboard between the grooves in pulleys with belts attached.
- Turn on the starter motor at least once a week to run the engine, enabling parts in contact with one another (pistons, rings and bearings, etc.) to change positions.
- Engines in storage must be inspected periodically. If there are signs of rust or corrosion occurring, remove the rust and apply grease.
- Check the overall state of safety of the ship thoroughly.

4.9. Measures to Take if the Engine is Submerged in Water

If the engine is submerged in water, remove the water from the engine as quickly as possible and contact a local HD Hyundai Infracore engine dealership to have the engine serviced.

Service technicians disassemble the engine to remove the salt from all components and reapply lubricant to all internal parts immediately.

Also, all electrical components are dried and damage due to corrosion from saltwater is inspected.

Such measures must be taken as quickly as possible. Delays may cause critical damage to the engine.

In particular, check whether there is salt or excessive moisture in the engine's fuel line system and install an automatic bilge pump to keep the depth of the water accumulated on the floor of the ship with the engine installed below the flywheel housing.

5. Main Components

5.1. Reduction Gear

For details about maintenance and handling techniques, refer to the reduction gear booklet provided separately.

5.1.1. Structure and operating principles

The reduction gear is used in high-speed engines and is composed of four main parts: an input shaft, gear shaft, output shaft and housing. The clutch for forward and reverse drive is a hydraulic, wet, multi-plate type. The structure and power transmission process are as follows.

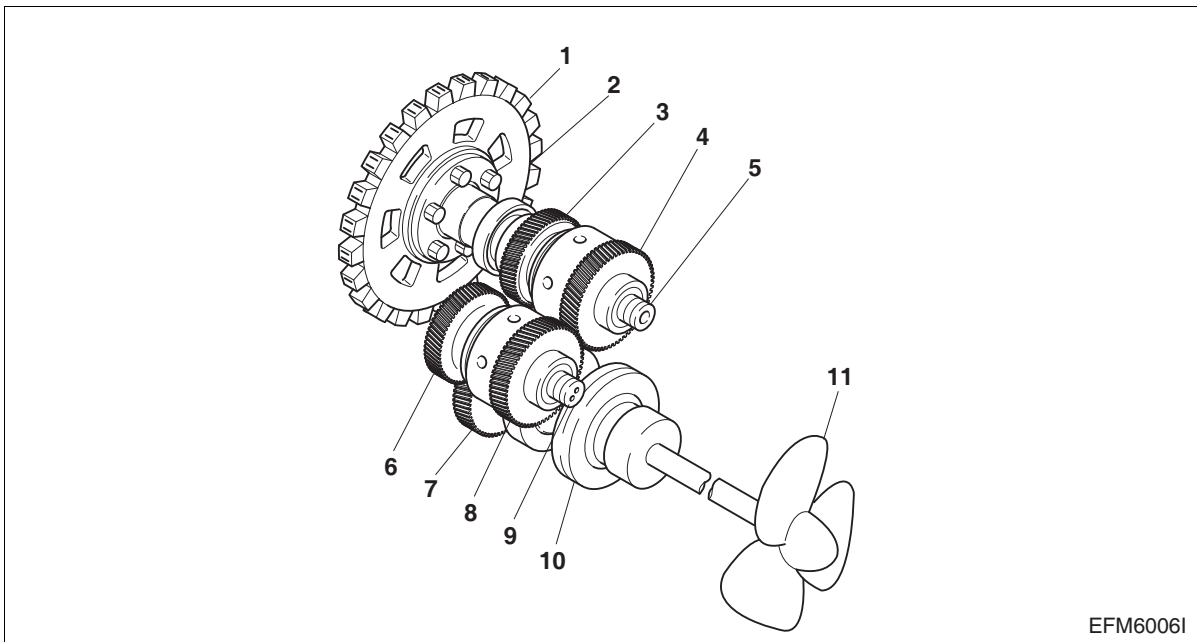

<Power line>

Neutral : 1 - 2 - 5 - 4 - 8

Forward : 1 - 2 - 5 - 3 - 7 - 10

Reverse : 1 - 2 - 5 - 4 - 8 - 9 - 6 - 7 - 10

- | | |
|-----------------------|-----------------------|
| 1. Rubber block | 6. Reverse pinion |
| 2. Spider | 7. Output shaft |
| 3. Forward pinion | 8. Reverse drive gear |
| 4. Reverse drive gear | 9. Gear shaft |
| 5. Input shaft | 10. Propeller shaft |

5.1.2. Characteristics

The reduction gear is composed of a forward shaft, reverse shaft, output shaft and valve body.

The valve body installed on the exterior is a device which controls the forward, neutral and reverse modes. It can also be adjusted remotely.

The oil delivered to the oil pump is supplied to the clutch assembly and the lubricated parts of each gear and bearing. When installing the reduction gear, take care to ensure that the power transmission shaft is aligned precisely in a straight line with the engine driveshaft.

5.1.3. Operation

1) Before operation

- Check the tightness of bolts and nuts in all components.
- Check the oil level with the oil dipstick.
(Before checking the oil level, idle the engine for several minutes and then stop the engine.)
- Place the reduction gear control lever in the neutral position before starting the engine.

2) Starting

- Idle the engine for 10 minutes.
- Check for leaks, abnormal sounds, temperature, etc. while idling the engine.
- Increase the engine rpm and check whether the clutch pressure is normal.

3) Driving and stopping

- Check whether the specified pressure is obtained while the clutch is engaged.
The pressure drops slightly at a low engine rpm but it does not affect the engine operation.
(Specified pressure : Refer to the attached drawing)
- When changing the gear to forward to reverse mode, idle the engine first before changing it.
- When the engine is running, the oil temperature must be maintained at 60 - 90 °C.
- To stop the engine, place the control lever in the neutral position and then stop it.

4) Emergency bolt

The emergency bolt is used as an emergency measure when the clutch slips while at sea and power is not transmitted to the propeller. Tightening the emergency bolt located on the forward clutch delivers power mechanically but only for driving forward. When using the emergency bolt, loosen the cover bolt first and disassemble the control block. Then, use a 5 mm L-wrench to tighten the 8 mm wrench bolt on top of the disk pack.

Next, reassemble the control block in the reverse order.

When the engine is started after tightening the bolt is complete, the propeller runs immediately and the ship moves forward.

At this time, take care to drive at less than half the usual speed.

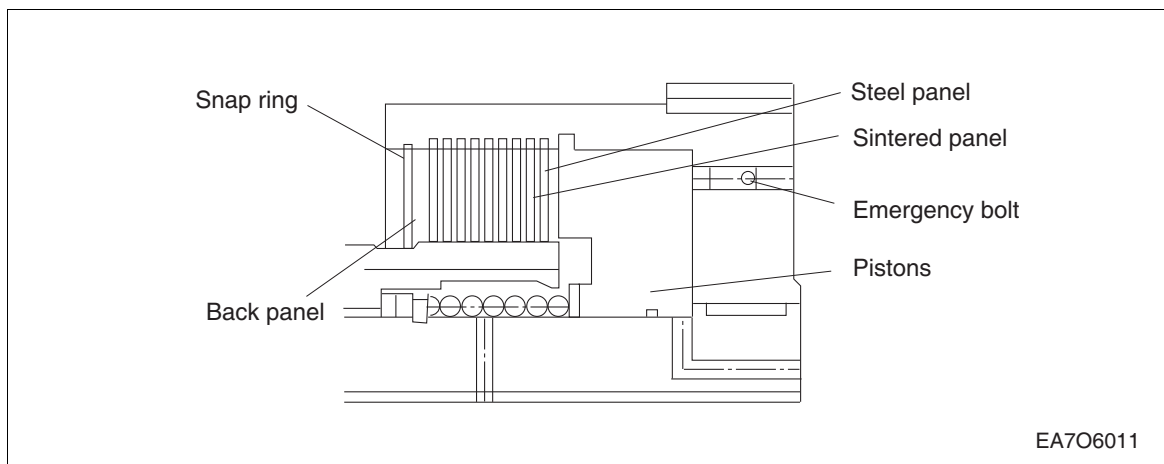

5.2. Front of Engine Power Takeoff (F.P.T.O.)

All auxiliary devices connected to and driven directly by the engine's crank pulley affect mostly warpage and vibrations in the engine. Excessive warpage and vibrations not only cause noise, gear malfunction and premature wear of the main bearing, but can even cause damage to the crankshaft in severe cases. Take care not to exceed the maximum usable limit for the front power takeoff recommended for each of the following models. These are the maximum values for power which can be transmitted by each clutch.

5.2.1. Maximum capacity of front power takeoff

In order to use the front power takeoff properly, install an elastic coupling on the front of the crank pulley as shown in the picture, connecting the engine with the PTO pulley (V-pulley) and driveshaft. Then, install two bearing blocks able to firmly support the PTO pulley and driveshaft on the front and back. HD Hyundai Infracore recommends installing the front power takeoff (FPTO) in this way in order to prevent engine warpage and vibrations.

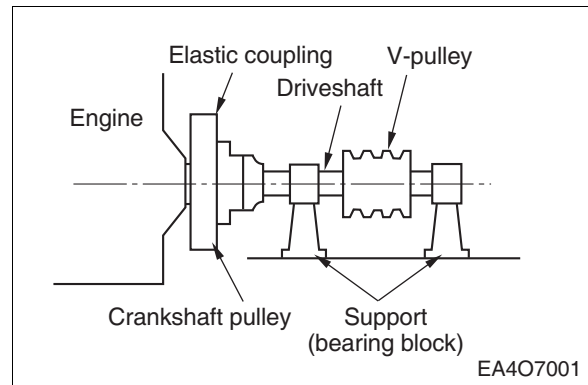

When using the FPTO to install the driveshaft of attachments, the deviation of the shaft from the central axis and the gap between the contact surface must each be less than 0.02 mm.

Engine Model	Rotational torque
4L126TIM	99 kg·m
4L126TIL	104 kg·m

5.2.2. Maximum allowable open power takeoff in open state

In the event that a support bearing is not used on the front of the PTO pulley as shown in the picture, the usable capacity varies significantly depending on how far the PTO pulley is from the tip of the crank pulley. When obtaining power in this way, it is easy for engine parts to be damaged (cracks in the crank pulley and bolt, premature wear of the main bearing, broken clutch, etc.) depending on the size of the load. Hence, it is safer to install a support bearing on the front whenever possible. If auxiliary power is used as shown in the picture, make sure the distance (L) from the tip of the crank pulley to the center line of the groove in the V-pulley is less than 60 mm for the sake of safety.

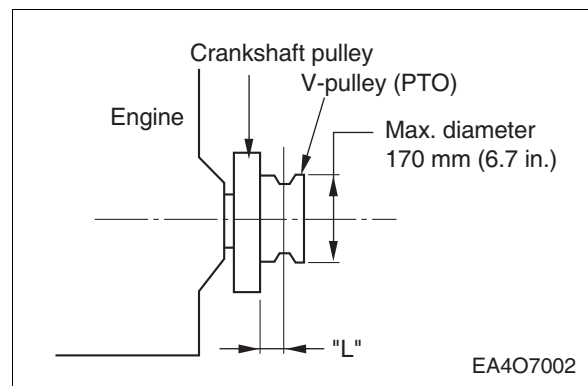

Engine Model	Rotational torque
4L126TIM	62 kg·m
4L126TIL	65 kg·m

5.3. Propeller

In order to obtain the maximum speed from the marine engine installed in the ship, the propeller must be set to provide optimum performance and efficiency under optimal conditions. In order to obtain the maximum usable horsepower (A), the engine rpm must be within the full-load range (B) indicated in the picture at the speed of the continuous rated power.

Refer to the engine performance curve in the "Engine Specifications" section included earlier in this manual.

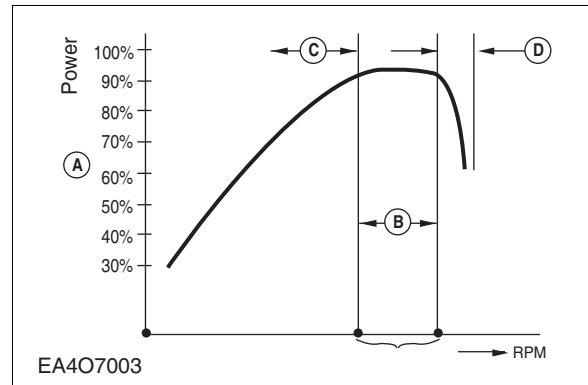

CAUTION

Choosing an unsuitable propeller causes damage to the engine. If the engine's continuous rated rpm exceeds the specified speed range while the hull is full, take the following measures.

- If the engine speed (rpm) fails to reach the specified "full-speed operating range" (section C), run the engine with a reduced propeller pitch.
- If the engine speed (rpm) exceeds the specified "full-speed operating range" (section D), enlarge the propeller pitch to run the engine.

6. Engine Service

6.1. Disassembly

6.1.1. Preparation

- Always work in a well-lit and clean environment.
- Before disassembly, prepare a shelf for the various tools and disassembled parts.
- Store disassembled parts in their disassembled order and be careful not to damage them.

6.1.2. Engine coolant

- Prepare a container, remove the coolant drain plug on the engine block and drain the coolant into the container.

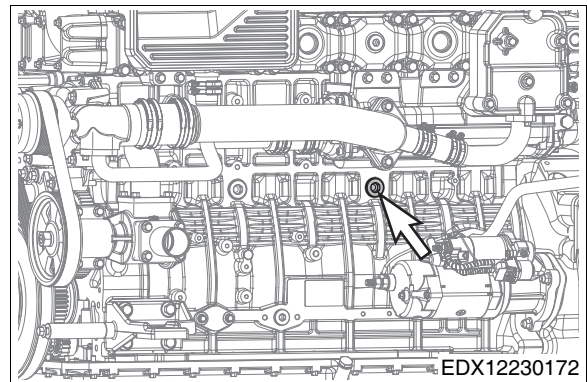

6.1.3. Engine oil drain pump

- Prepare a container, run the oil drain pump and drain the engine and reduction gear oil into the container.
- Disconnect the rubber hose connected to the oil pan and reduction gear.
- Remove the oil drain pump mounting bolt and remove the oil drain pump.

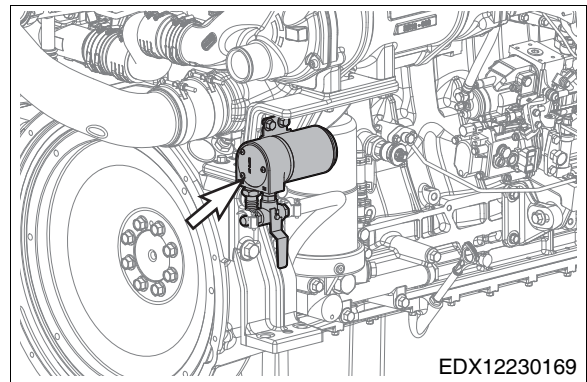

6.1.4. Belt

- Rotate the auto tensioner clockwise to loosen the belt, then remove the rubber belt.

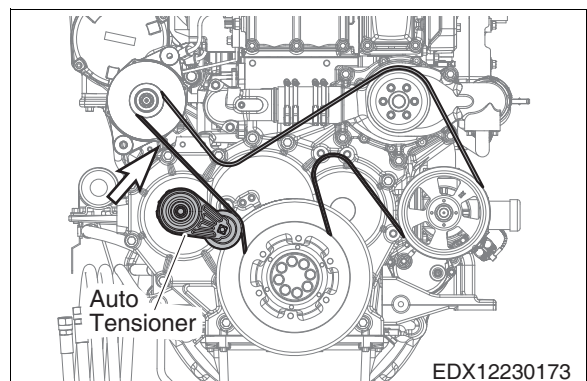

6.1.5. Alternator

- Loosen the alternator mounting bolt, then remove the protective cover and alternator.

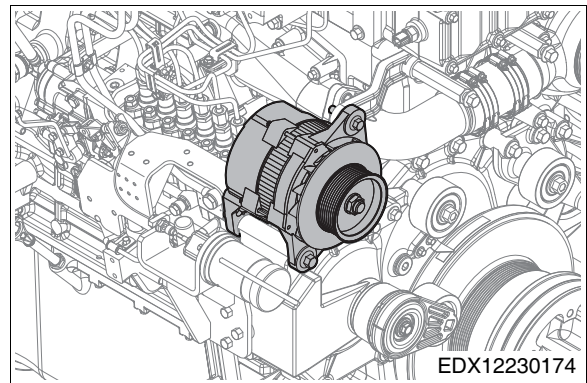

6.1.6. Engine stop solenoid

- Disconnect the cable connected to the solenoid and fuel stop lever.
- Disassemble the engine stop solenoid.

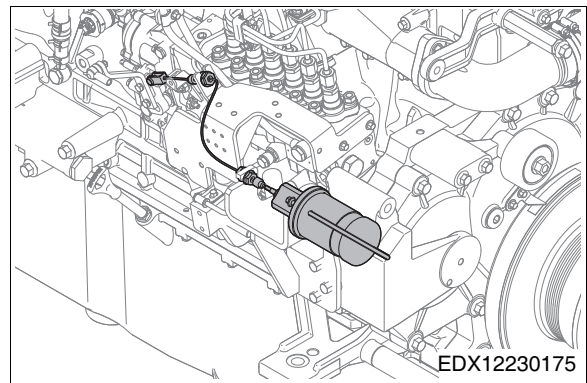

6.1.7. Fuel filter and mounting bracket

- Unscrew hollow screws (A) on the fuel filter and disconnect the fuel pipes.
- Unscrew fuel filter mounting bolts (B) and remove the fuel filter.

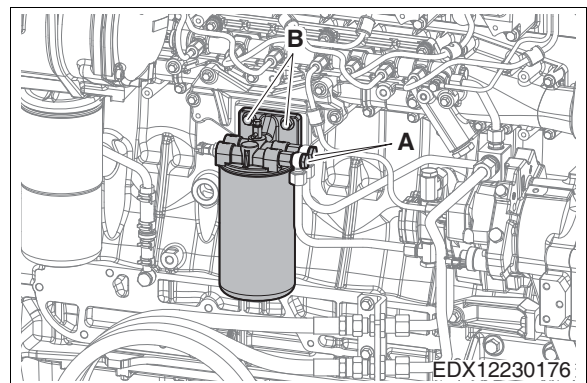

- Unscrew fuel filter bracket mounting bolts (B) and remove the bracket.

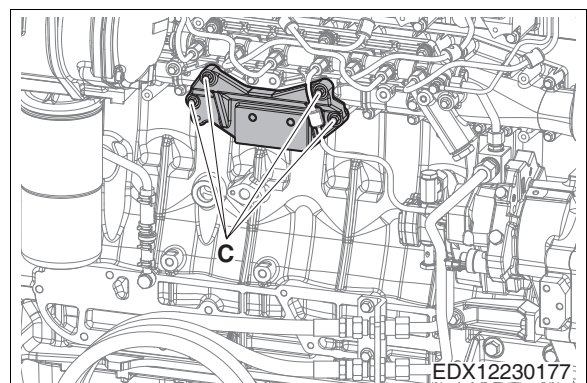

6.1.8. Breather

- Loosen the breather hose mounting clamp on top of the cylinder head cover and remove the rubber hose.

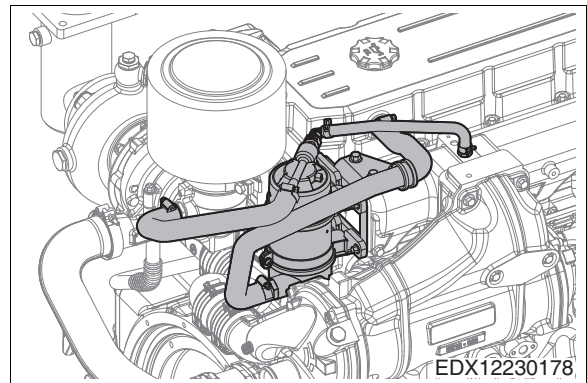

6.1.9. Air filter

- Detach the filter element.
- Loosen the clamp and remove the air filter.

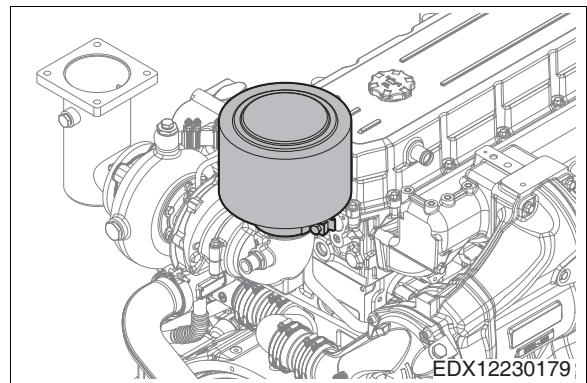

6.1.10. Intercooler

- Detach the coolant pipe from the intercooler.
- Remove the air pipe from the turbocharger.
- Disassemble the intercooler.

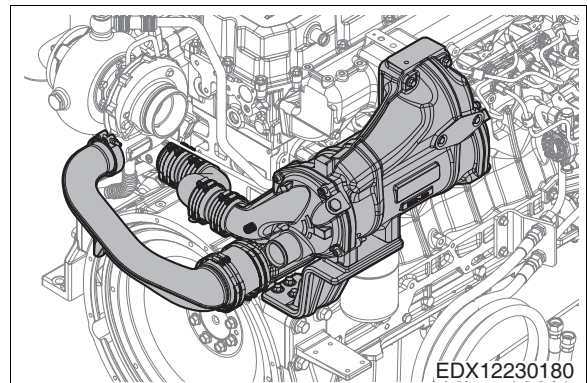

6.1.11. Turbocharger

- Loosen the clamp on the rubber hose connected to the turbocharger inlet and remove the intake pipe.
- Loosen the nut on the exhaust outlet pipe installed on the turbocharger and disassemble the exhaust pipe.
- Disconnect the oil supply pipe and return pipe on the turbocharger, then loosen the turbocharger mounting nut and disassemble the turbocharger.

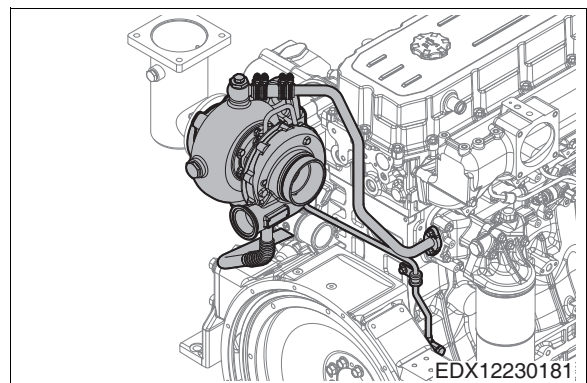

6.1.12. Reservoir tank

- Disconnect the pipe connected to the reservoir tank.
- Loosen the reservoir tank bracket mounting bolt and remove the reservoir tank.

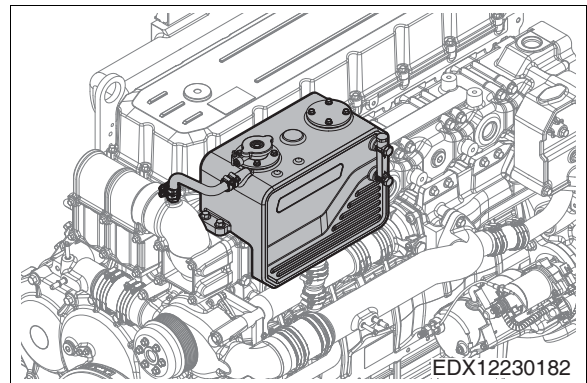

6.1.13. Fuel injection pipes

- Disconnect the injection pipes on cylinders 1 to 6 between the high-pressure fuel connectors and the common rail.
- Disconnect the injection pipe between the fuel pump and the common rail.



CAUTION:

There may be fuel remaining in the injection pipes, so be careful not to spill fuel when removing nuts.



CAUTION:

Injection pipes are designed to maintain an airtight seal; if they are reused, the metal may be deformed, causing the pipes to lose their airtightness and resulting in leaks. Make sure to replace them with new ones during removal and reassembly.



CAUTION:

Injection pipes act as seals for high-pressure fuel lines; never reuse them.

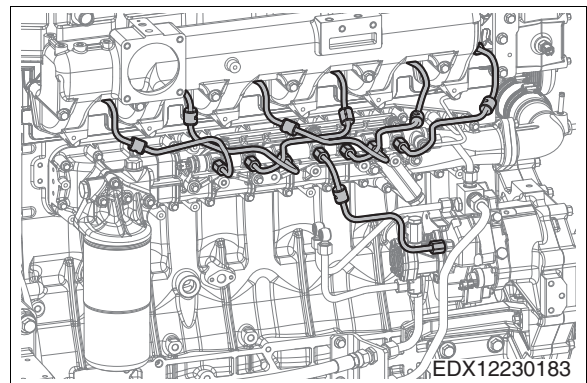

6.1.14. Common rail and mounting bracket

- Unscrew hollow screws (A) on the cylinder head and common rail, and disconnect the fuel return pipe.

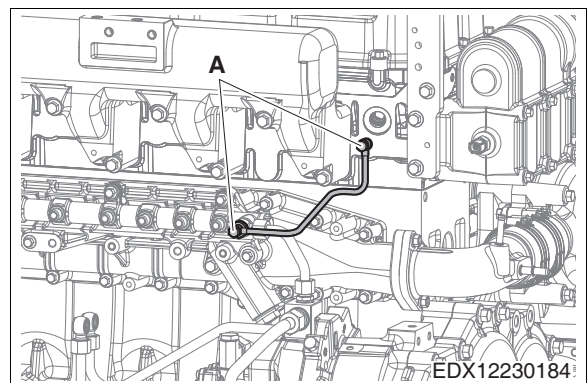

- Unscrew common rail hollow screw (B) and fuel pump hollow screw (C); then, unscrew pipe union nut (D) and disconnect the return pipe.

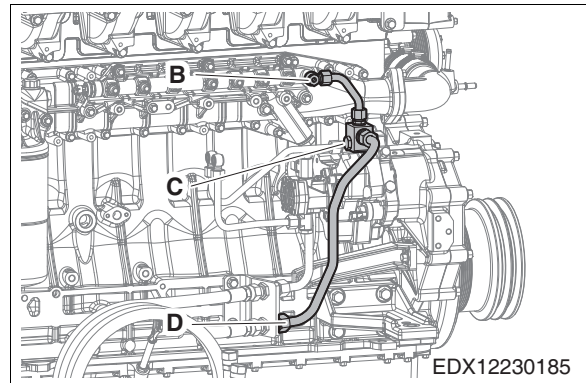

- Unscrew common rail mounting bolts (E) and remove the common rail.

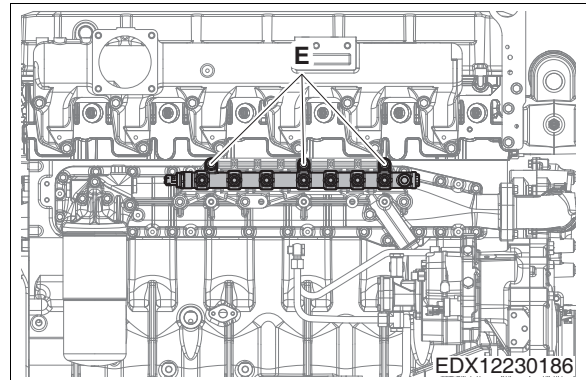

- Unscrew common rail bracket mounting bolts (F) and remove the bracket.

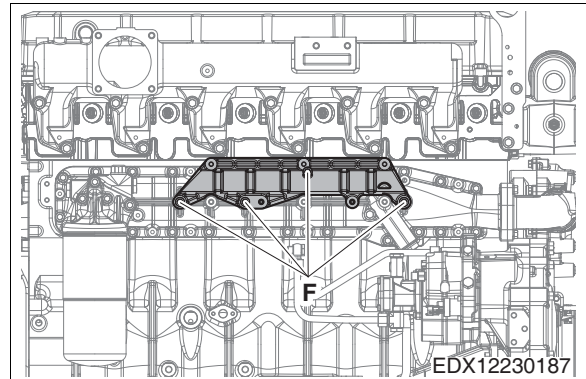

6.1.15. Intake manifold

- Disconnect the air hose connected to the fuel injection pump.
- Loosen the intake manifold mounting bolt and remove the intake manifold.

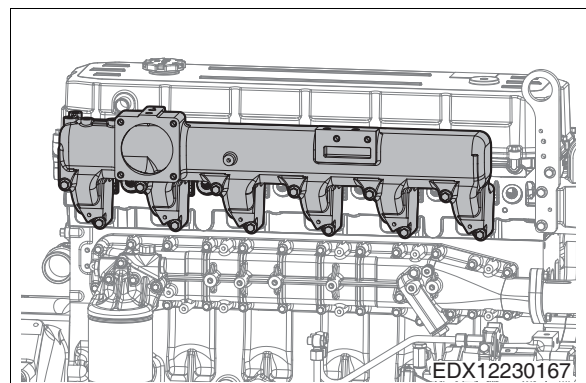

6.1.16. Thermostat

- Disconnect the hose and bypass pipe connected to the coolant pump. Loosen the thermostat mounting bolts connected to the exhaust manifold and heat exchanger, then remove the housing.
- Remove the thermostat.

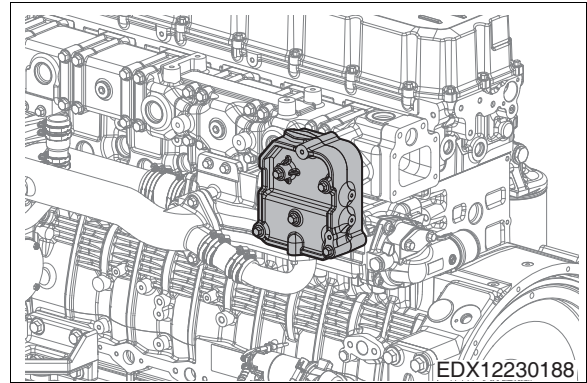

6.1.17. Heat exchanger

- Loosen the rubber hose mounting clamps connected to both sides of the heat exchanger, then disconnect the rubber hose.
- After removing the exhaust manifold, loosen the heat exchanger mounting bolts connected to it and remove the heat exchanger.

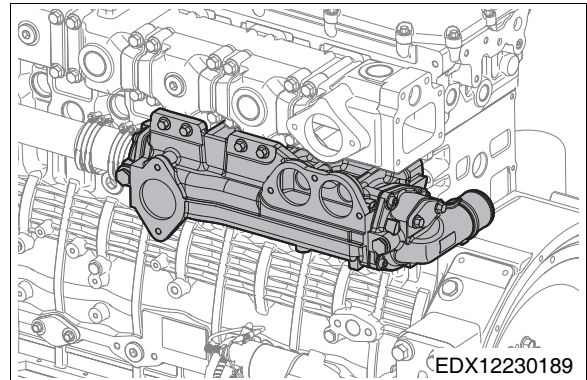

6.1.18. Exhaust manifold

- Loosen the exhaust manifold mounting bolts, disconnect the heat exchanger and exhaust manifold assembly, then remove the heat exchanger and gasket.



CAUTION

The exhaust manifold assembly is very heavy so be careful during disassembly.

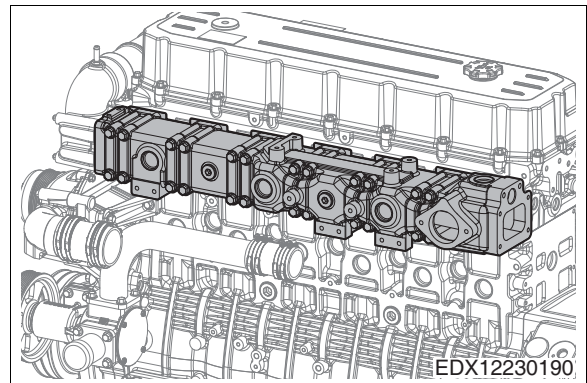

6.1.19. Starter Motor

- Loosen the starter motor mounting bolts, then remove the starter motor.

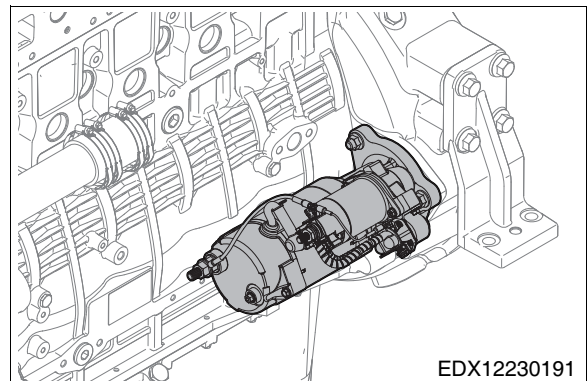

6.1.20. Saltwater pump

- Loosen the rubber hose mounting clamp connected to the saltwater pump, then remove the rubber hose.
- Loosen the mounting bolts on the PTO housing integrated with the saltwater pump, then remove the saltwater pump assembly.

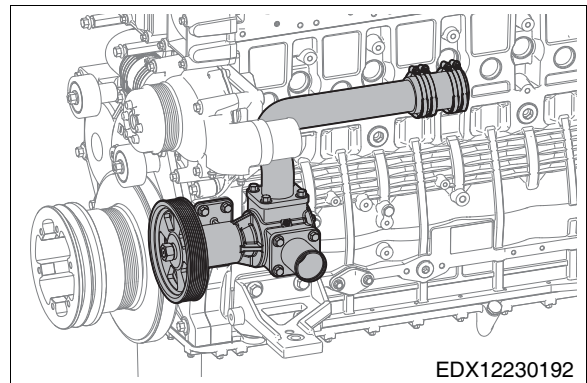

6.1.21. Coolant pump

- Remove the coolant pipe connected to the oil cooler.
- Disconnect the coolant pipe and hose connected to the heat exchanger.
- Unscrew the coolant pump mounting bolts and remove the coolant pump.

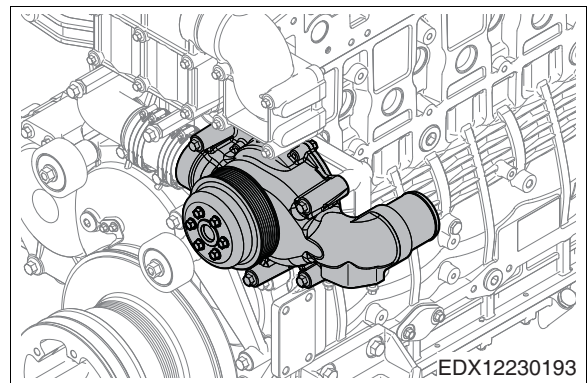

6.1.22. Fuel pump

- Unscrew hollow screws (A) and union nuts (B, C) connected to the fuel pump, and disconnect the fuel pipes.



CAUTION

There may be fuel remaining in the fuel pipes, so be careful not to spill fuel when removing nuts.

- Unscrew the fuel pump mounting bolts and remove the fuel pump.



CAUTION

After disassembling the fuel pump, seal it to prevent foreign matter from entering.

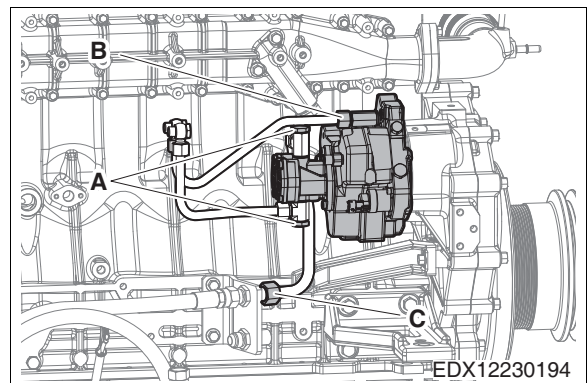

6.1.23. Oil filter

- Use a filter removal wrench to remove the cartridge.
- Disconnect the pipe connected to the oil cooler.
- Loosen the oil filter mounting bolts and remove the oil filter housing from the cylinder block.

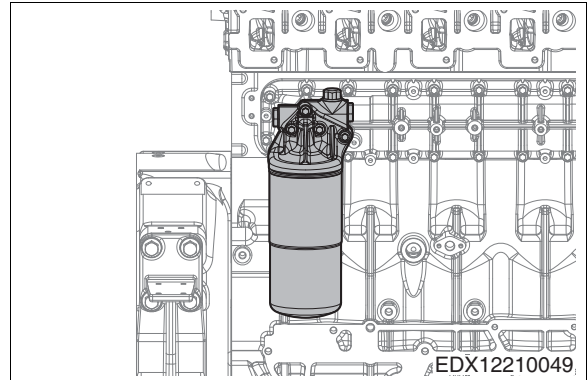

6.1.24. Water chamber

- Remove the 10 bolts installed on the water chamber, then remove the water chamber.

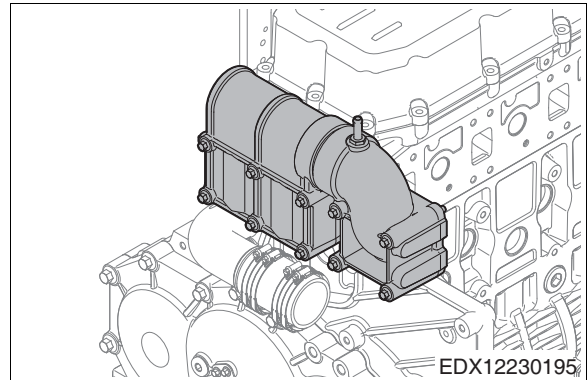

6.1.25. Vibration damper

- Unscrew the pulley mounting bolts and remove the vibration damper assembly.
- Unscrew the vibration damper mounting bolts and remove the vibration damper from the pulley.

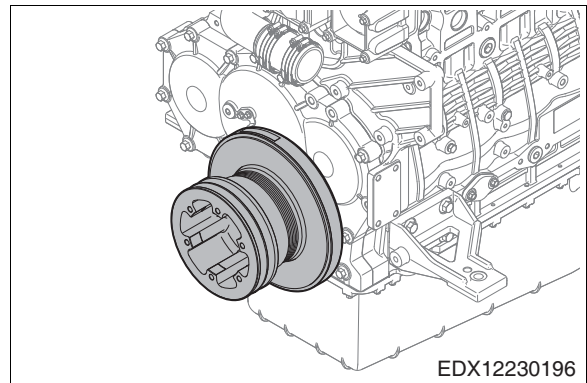

6.1.26. Timing gear case cover



- Use an oil seal removal jig to remove the oil seal.
- Unscrew the cover mounting bolts and remove the cover from the timing gear case.

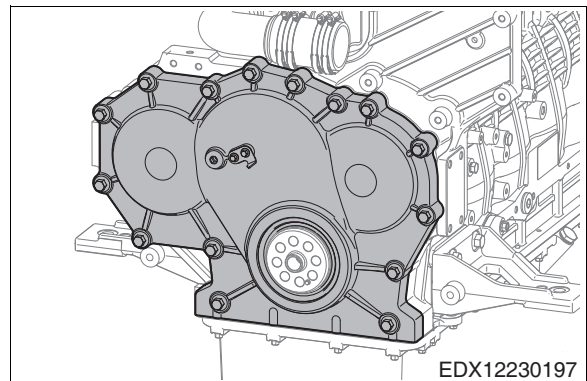

6.1.27. Idler gear

- Loosen the idler gear mounting bolts and remove the idler gear pin and gear.
- Use a rubber hammer to remove the idler pin without damaging it.

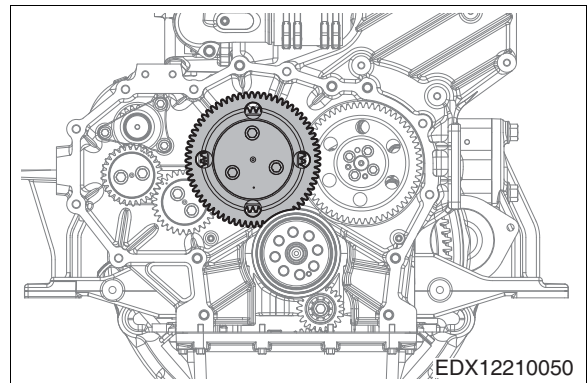

6.1.28. Cylinder head cover

- Unscrew the cover mounting bolts and remove the cover.

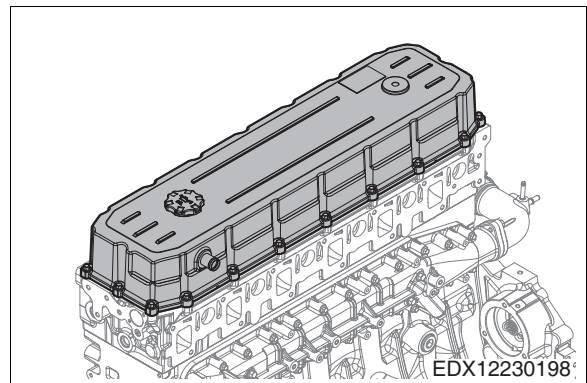

6.1.29. Rocker arm assembly

- Unscrew the rocker arm bracket bolts and remove the rocker arm assembly.
- Remove the calipers after removing the rocker arm assembly.

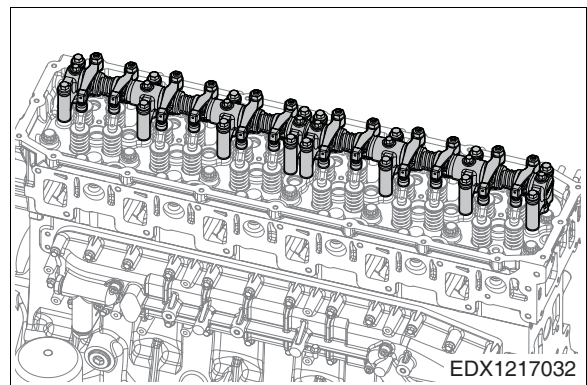

- Remove the pushrods.

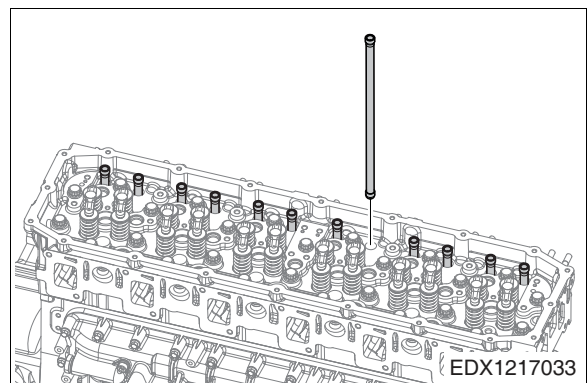

6.1.30. Injectors

- The O-rings on the injectors and high-pressure fuel connectors are always installed; they do not require separate assembly.

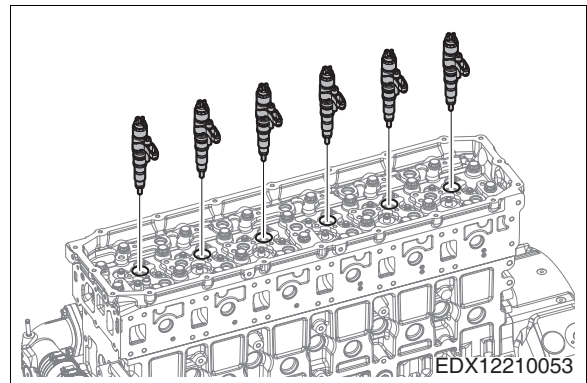

- Remove the fuel in/out hoses from the fuel tank and drain the return fuel (g) in the cylinder head.



CAUTION:

If the injectors and high-pressure fuel connectors (HPC) are removed without draining the return fuel in the cylinder head, the return fuel may enter the combustion chamber and cause white smoke or piston damage.

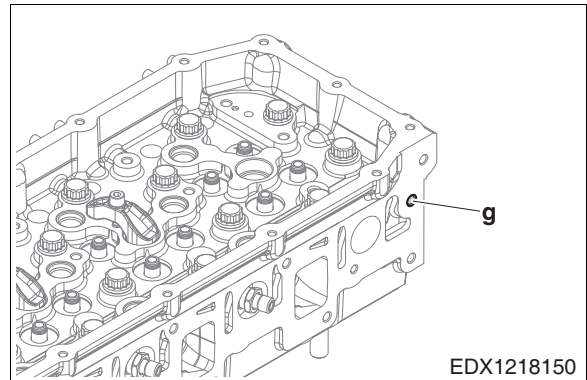

Loosen the high-pressure fuel connector mounting nuts and remove the high-pressure fuel connector.

- The high-pressure fuel connector cannot be reused after being removed.
- Remove the harness connected to the injector, unscrew the injector mounting caliper bolt, and remove the injector.
- Be careful not to damage the nozzle while removing the injector.
- Pull out the seal ring from the nozzle hole on the cylinder head and discard it.



CAUTION:

- 1 When removing the injector, unscrew the high-pressure fuel connector mounting nut and completely disconnect the high-pressure fuel connector. Then, unscrew the mounting bolt on the injector mounting bracket and remove the injector.
 - 2 Seal the injector and high-pressure fuel connector after removing them to prevent foreign matter from entering.
- Check whether any injector sealing washers remain in the grooves on the cylinder head; if any are found, remove them using pincers or a suitable tool.

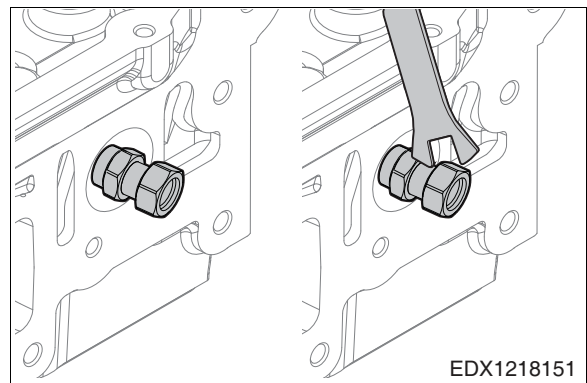



CAUTION:

Remove injectors after high-pressure fuel connectors (HPC) have been completely removed.

6.1.31. Cylinder head

- Unscrew the cylinder head mounting bolts and remove the cylinder head.
- Remove the cylinder head gasket.

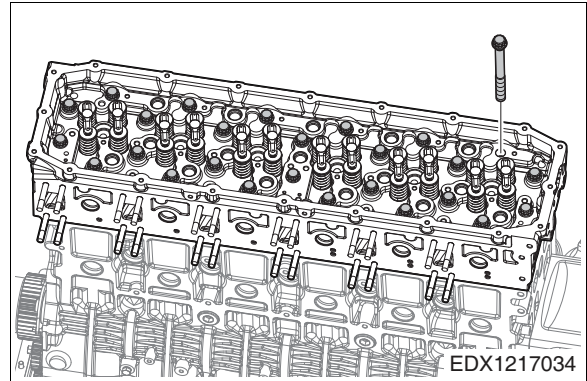

6.1.32. Valve and valve stem seal



- Apply pressure to the valve spring retainers with a jig to remove the valve cotter pins.
- Remove the valve springs and retainers.
- Remove the valves.
- Use regular tools for removal. Dispose of the valve stem seals so that they cannot be reused.

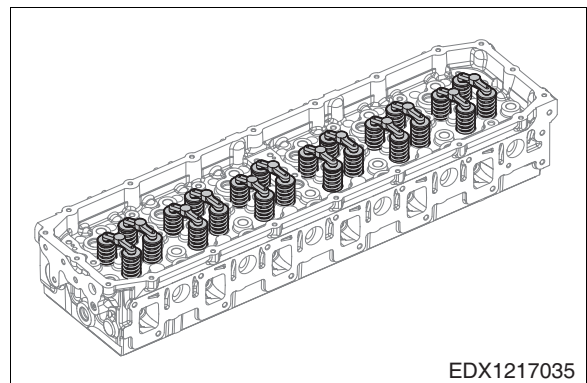

6.1.33. Oil cooler

- Remove the coolant pipe connected to the fresh water pump.
- Unscrew the oil cooler cover mounting bolts and remove the oil cooler assembly from the cylinder block.
- Unscrew the oil cooler mounting bolts and remove the oil cooler from the cover.

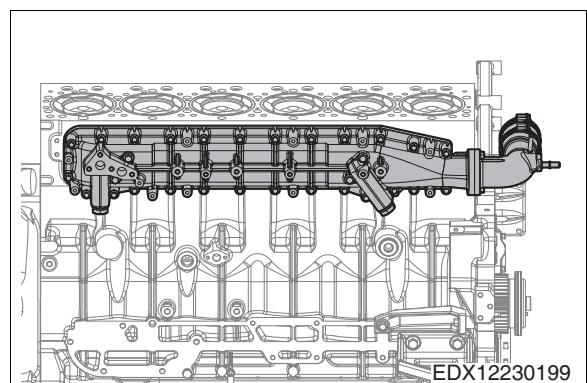

6.1.34. Oil pan

- Position the engine so that the flywheel faces the ground.
- Unscrew the oil pan mounting bolts to remove the oil pan and gasket.

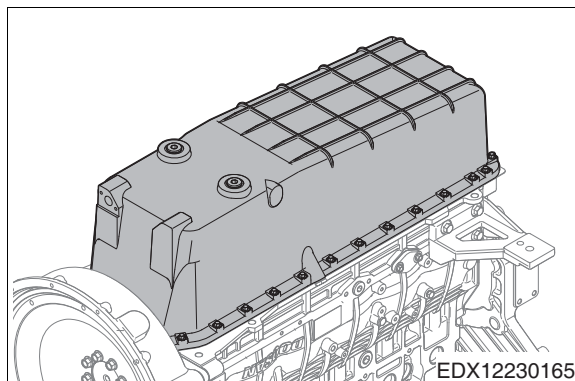

6.1.35. Oil pump oil pipe

- Loosen the oil suction pipe mounting bracket and support bolts to remove the oil suction pipe assembly.
- Disconnect the oil pipe which supplies oil from the oil pump to the cylinder block.
- Unscrew the oil pump mounting bolts and remove the oil pump.

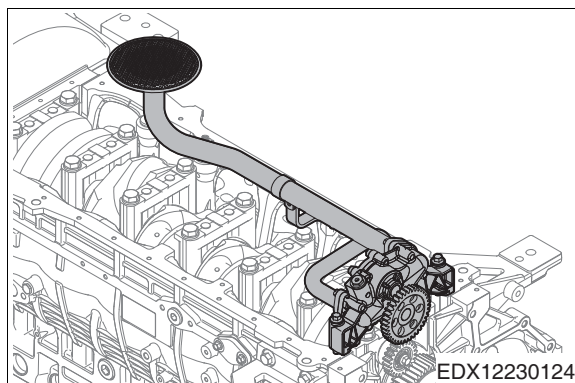

6.1.36. Relief valve

- Remove the relief valve installed on the bottom of the cylinder block.

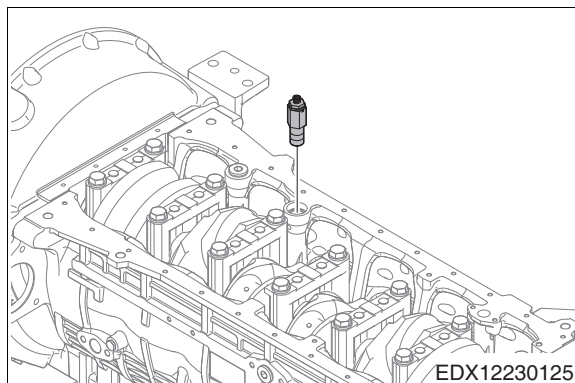

6.1.37. Pistons and connecting rods

- Turn the crankshaft and remove the pistons two at a time.
- Unscrew the connecting rod bolts to remove the bearing caps, then disassemble the pistons and connecting rods in the direction of the pistons as shown in the picture.

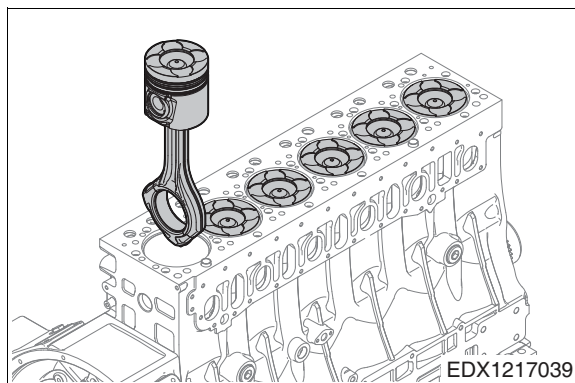



- Remove the piston pin snap rings to remove the piston pins, then remove the connecting rods and pistons.

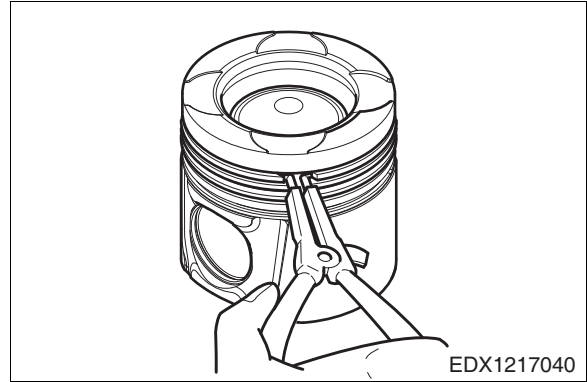

- Use ring pliers to remove the piston rings.
- Be careful not to mix up disassembled parts. Store the parts for each cylinder in order.

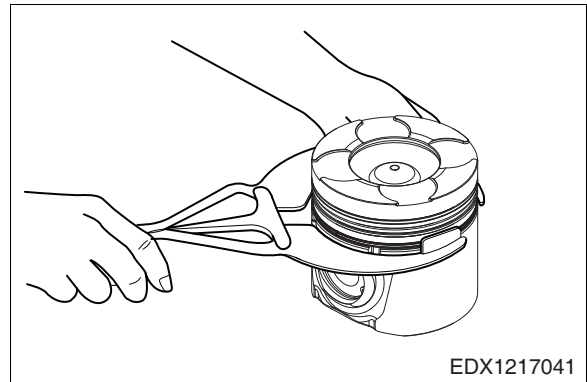

6.1.38. Cylinder liner

- Using a wooden or plastic rod, push up on the bottom of the cylinder liner underneath the engine to lift it slightly and remove the cylinder liner.

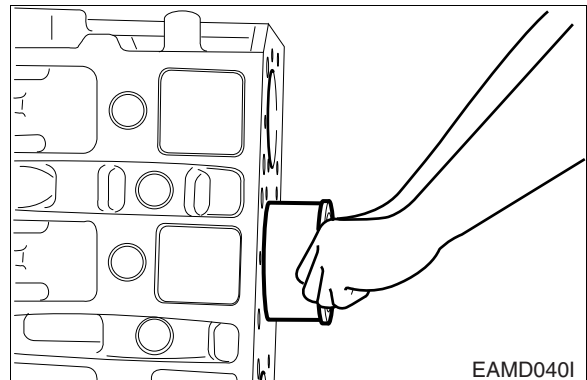

6.1.39. Flywheel

- Position the engine so that the head assembly surface on the cylinder block faces downwards.
- Install the flywheel removal stud bolts in the bolt holes drilled into the flywheel and remove the flywheel.

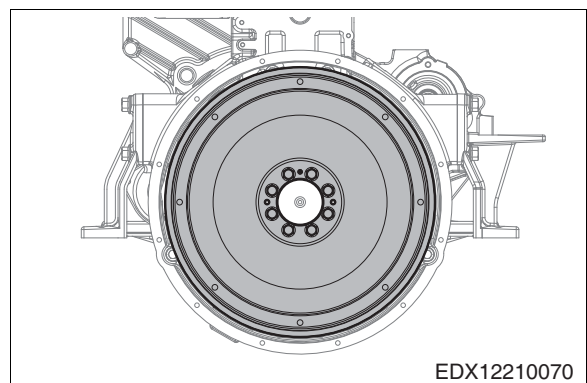

6.1.40. Oil Seal



- Use an oil seal removal jig to remove the rear oil seal.

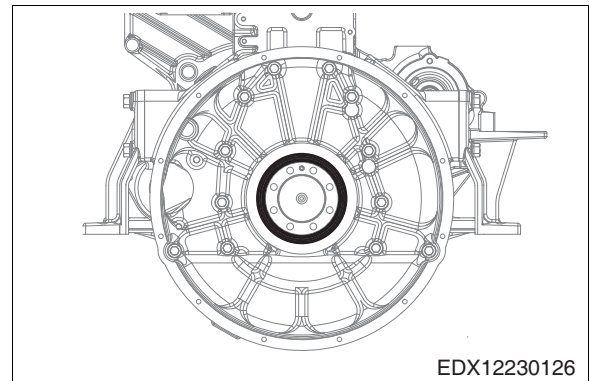

6.1.41. Flywheel housing

- Unscrew the housing mounting bolts and remove the flywheel housing.

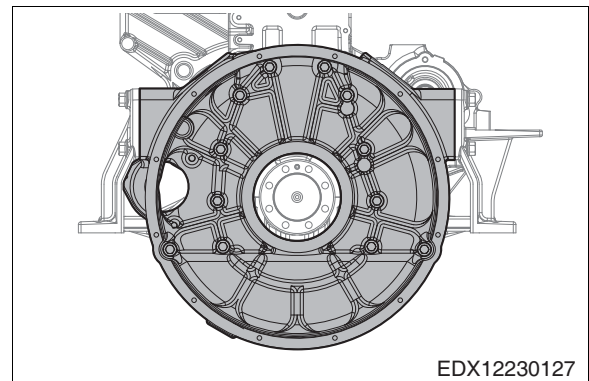

6.1.42. Camshaft idler gear and cam gear

- Unscrew the idler gear mounting bolts and remove the idler gear pin.
- Remove the camshaft gear mounting bolts to remove the camshaft gear.

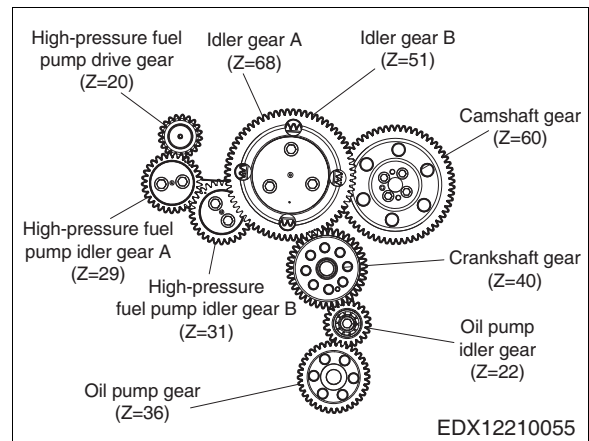

6.1.43. Camshaft and tappet

- Remove the camshaft gear.
- Remove the camshaft gear thrust washer.
- Remove the camshaft while taking care not to damage it.
- Push the tappet out by hand.

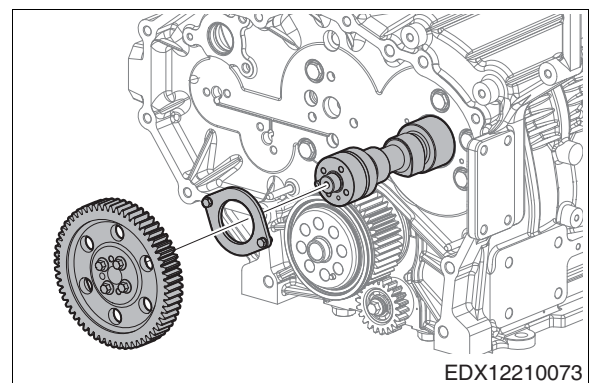

6.1.44. Crankshaft gear and oil pump idler gear

- Unscrew the bolt and remove the oil pump idler gear.
- Use a puller to remove the crankshaft gear.

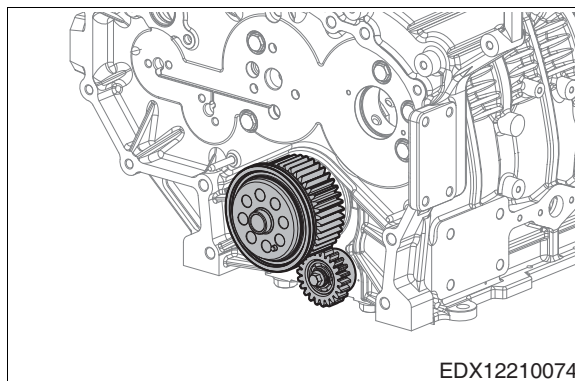

6.1.45. Timing gear case

- Unscrew the case mounting bolts and remove the timing gear case.
- Tap the rear left and right sides on the contact surface of the timing gear case with a urethane hammer gently to remove the timing gear case.

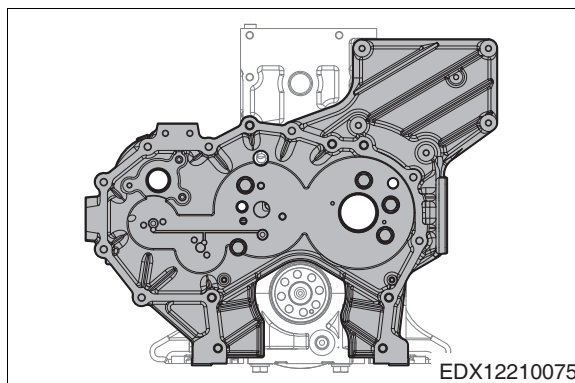

6.1.46. Crankshaft

- Unscrew the main bearing cap mounting bolts to remove the bearing caps.
- Lift the crankshaft to remove it.
- Remove the main bearings.

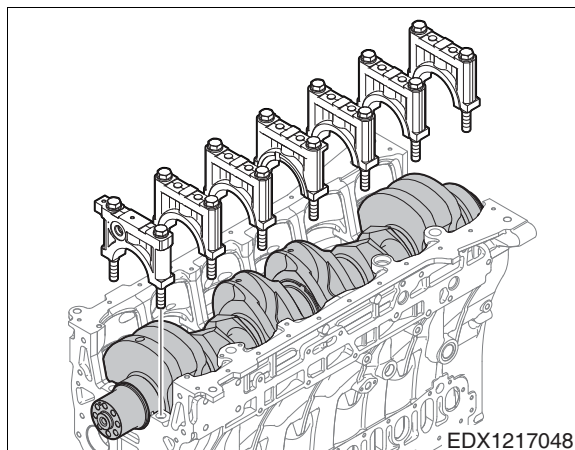

6.1.47. Oil injection nozzle

- Unscrew the oil spray nozzle mounting bolts on the inside of the cylinder block to remove the oil injection nozzles.

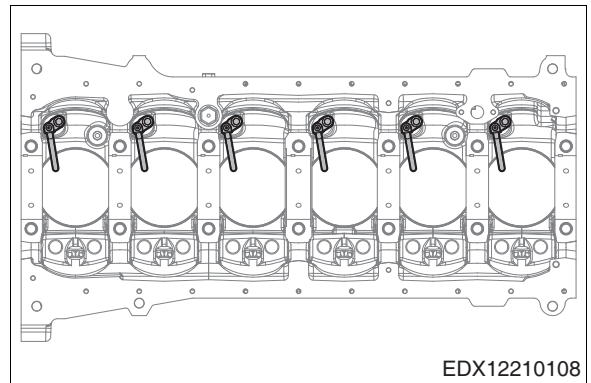

6.2. Checking the Main Components

6.2.1. Cylinder block



- 1) Clean the cylinder block thoroughly and check for any cracks or damage.
- 2) If it is severely cracked or damaged, replace it with a new one. Correct any minor damage.
- 3) Check the oil and coolant passages for clogging or corrosion.

Perform a test for cracks or gas leaks.

Hydrostatic test : Plug the various outlets (coolant and oil passages, etc.) in the cylinder block and apply approx. 4 kg/cm² of air pressure to the inlet. Then, submerge it in water for approx. one minute and check for air leaks. (Water temperature : 70 °C)

6.2.2. Cylinder Head



- 1) Checking for cracks or damage
 - Using a non-metallic tool, remove any carbon residue from the bottom surface of the cylinder head.
 - Be careful not to scratch the valve seat surface while doing so.
 - Perform a hydrostatic test or magnetic particle test to check for small cracks or damage that cannot be identified with the naked eye.



- 2) Checking the warpage of the bottom surface
 - Use a straightedge and feeler gauge to measure the warpage of the head in six directions as shown in the picture on the right.
 - If the measured value exceeds the standard value, use fine grinding paper or a fine surface grinder to correct it.
 - If the measured value exceeds the maximum allowable limit, replace the cylinder head.

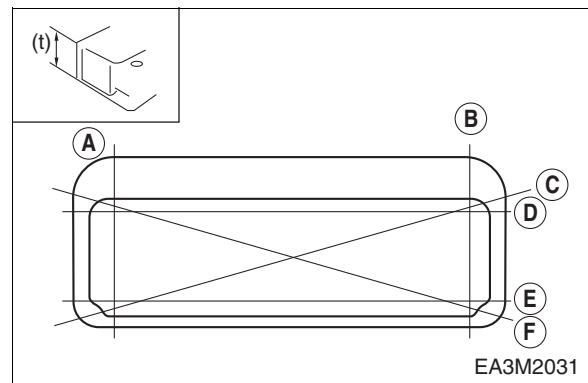

<Measuring the deflection and thickness of the bottom of the cylinder head>
(mm)

Item	Standard	Limit
Surface deflection	0.2 or less	0.3
Thickness : t (Standard)	154.7 ~ 155.3	153.9

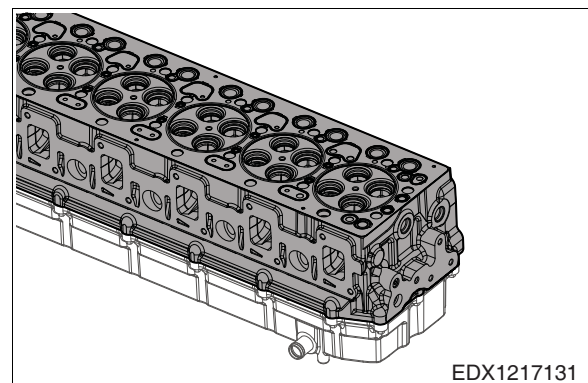



3) Flatness

Measure the flatness of the intake/exhaust manifold mounting surface on the cylinder head with a straightedge and feeler gauge.

<Measuring the deflection and thickness of the bottom of the cylinder head>

Standard	Limit
0.05 mm	0.2 mm



4) Hydrostatic test

Perform the hydrostatic test for the cylinder head in the same way as the test for the cylinder block.

6.2.3. Valve and Valve Guide

1) Replace the valve



After cleaning the valve with diesel fuel, measure the outside diameter of the valve stem at the top, middle and bottom as shown in the figure to check for wear.

Repair slightly damaged parts. Replace valves whose wear exceeds the limit.

<Valve stem O.D.>

(mm)

Dimensions Description	Standard	Limit
Intake valve stem	Ø7.963 ~ Ø7.977	Ø7.943
Exhaust valve stem	Ø7.950 ~ Ø7.964	Ø7.920

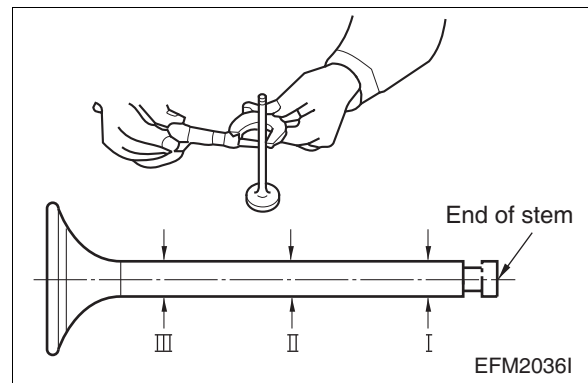

● Valve seat contact surface

Check for scratches or wear on the valve seat contact surface and polish the contact surface with sandpaper if necessary. Replace if severely damaged.



- Valve head thickness
Measure the thickness of the valve head and replace the valve if the measured value exceeds the limit.

(mm)

Dimensions Description	Standard	Limit
Intake valve	3.3 ~ 3.7	2.8
Exhaust valve	4.0 ~ 4.4	3.5

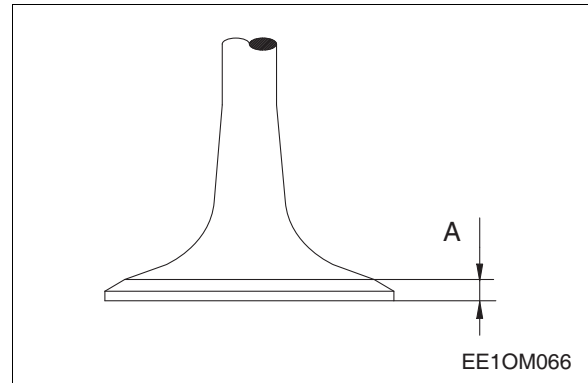

2) Valve Guide

- Install the valve and valve guide, and measure the clearance between the valve and valve guide resulting from valve movement. If the clearance is too great, measure the valve and replace either the valve or valve guide (whichever part is more severely worn).

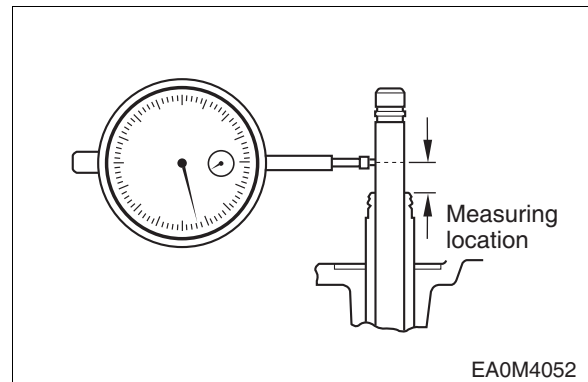

<Valve stem end play>

(mm)

	Standard	Limit
Intake valve	0.023 ~ 0.052	0.10
Exhaust valve	0.036 ~ 0.065	0.15



- Assemble the valve with the cylinder head valve guide and use a special tool to measure whether the central line of the valve guide and valve seat is aligned.

3) Valve seat



- Check the valve seat for wear or damage and replace if necessary.
- Assemble the valve with the cylinder head valve seat and use a measuring instrument on the bottom surface of the cylinder head to measure the projection of the valve. Replace the valve seat if the measured value exceeds the limit.

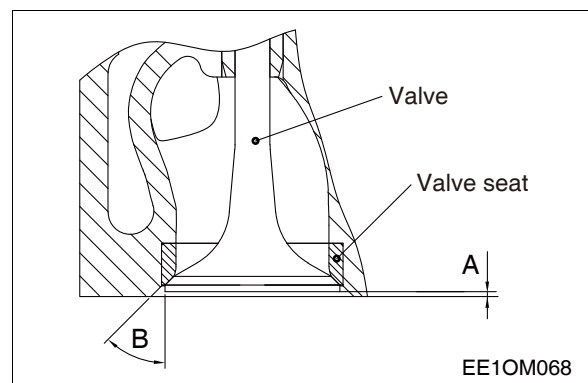

<Valve protrusion>

(mm)

	Standard
Intake valve (A)	0.66 ~ 0.96
Exhaust valve (A)	0.60 ~ 0.90

<Valve angle>

	Standard
Intake valve (B)	60°
Exhausts valve (B)	45°

- When removing the valve seat, weld beads onto the seat inserted into the head and use a special tool to remove it.
- Cool and contract the valve seat in dry ice for around one hour. Then, use a special tool to insert it into the cylinder head. (The bore of the inner diameter requires drilling when replacing the valve seat)
- Spread an abrasive on the valve head contact surface of the valve seat and rotate the valve to polish it until it fits in place. Then, wipe off any abrasive remaining on the valve and head surface with oil.

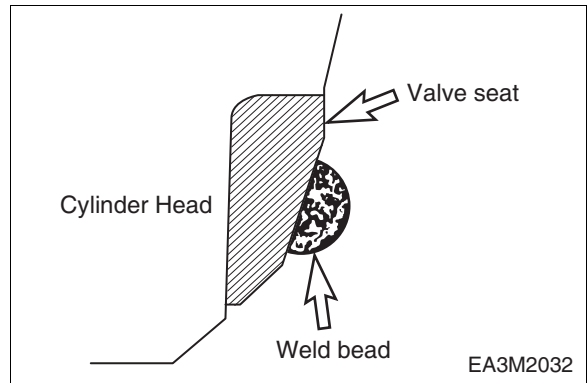
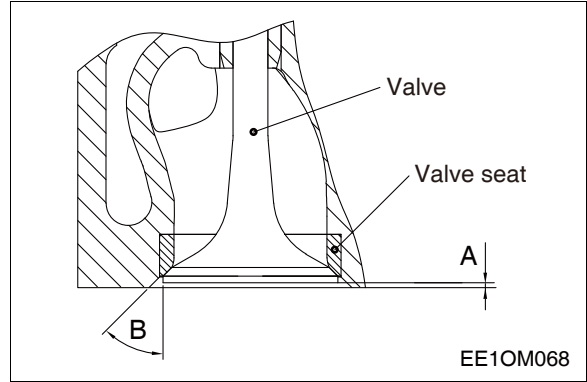

Note :

When the valve seat has been prepared, use diesel fuel or an equivalent product to clean the valve and cylinder head and check for any abrasive remaining.

4) Valve spring



- Check the exterior for any scratches on the valve spring and replace the spring if necessary.



- Measure the free length and tension of the valve spring.

(mm)

		Free length
Intake valve	Inside	-
	Outside	62.5
Exhaust valve	Inside	-
	Outside	62.5

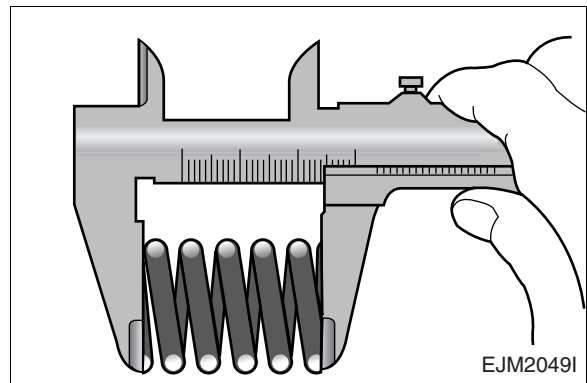

- Measure the squareness of the valve spring.
- Compare the measured value with the standard value.



- Valve spring squareness
Use a surface plate and straightedge to measure the squareness of the valve spring.
If the measurement exceeds the allowable limit, replace the valve spring.

(mm)

		Standard	Limit
Intake valve	Inside	-	-
	Out-side	1.6	2.0
Exhaust valve	Inside	-	-
	Out-side	1.6	2.0

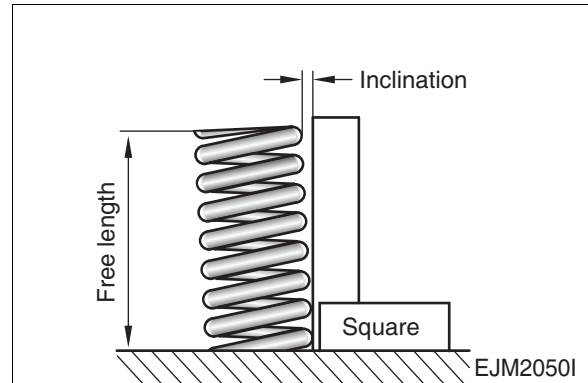

- Measure the squareness of the valve spring.
- Compare the measured value with the standard value.

<Valve spring tension>

		Set length (P1/P2)	Spring force (P1/P2)	Limit (P1/P2)
Intake Valve External		44.0 mm/	39.4 kg/	±2.0 kg/
		31.6 mm	65.8 kg	±2.5 kg
Exhaust Valve External		44.0 mm/	39.4 kg/	±2.0 kg/
		31.6 mm	65.8 kg	±2.5 kg

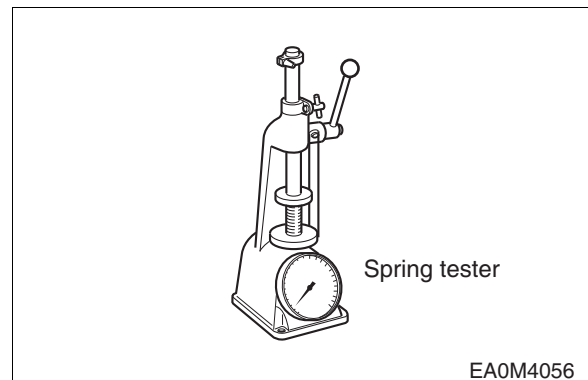

6.2.4. Rocker arm shaft assembly

1) Rocker arm shaft



- Rocker arm shaft runout
Place the rocker arm shaft on two V-blocks and use a dial gauge to check whether the shaft is bent.
If the runout value is small, apply pressure to the shaft with a bench press to correct the runout. Replace the shaft if the measured value exceeds the limit.

(mm)

Limit	0.2
-------	-----

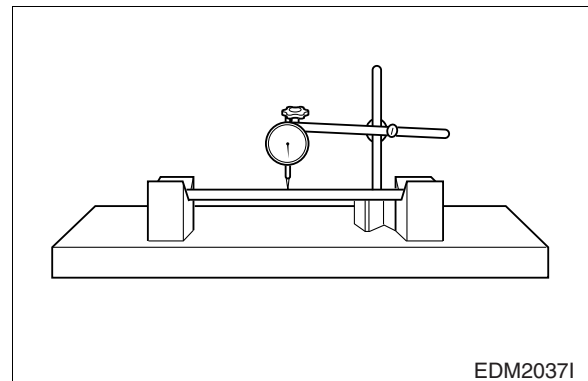



- **Rocker arm shaft diameter**
Use an outside micrometer to measure the diameter of the rocker arm shaft at the place where the rocker arm is installed.
Replace the rocker arm if the amount of wear exceeds the specified limit.

(mm)

Standard	Limit
Ø24.953 ~ Ø24.976	Ø24.916

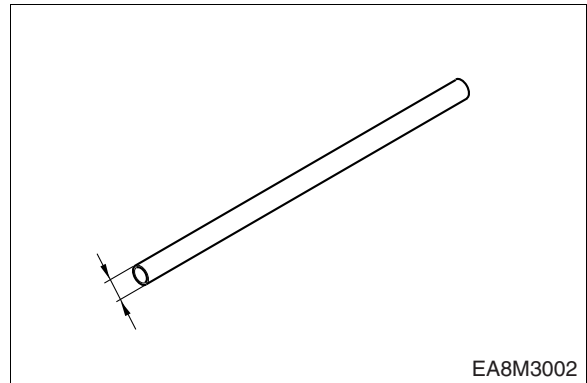

2) Rocker arm



- **Visual inspection**
Perform a visual inspection for wear such as scratches or bumps on the surface of the rocker arm where it makes contact with the front end of the valve stem. If the wear is minimal, use fine sandpaper or an oil stone to correct it. Rocker arms with severe bumps must be replaced.



- **Rocker arm bushing diameter**
Use an inside micrometer or vernier caliper to measure the inside diameter of the rocker arm bushing and compare the measured value with the diameter of the rocker arm shaft. If the clearance exceeds the limit, replace either the bushing or the shaft (whichever part is more severely worn).

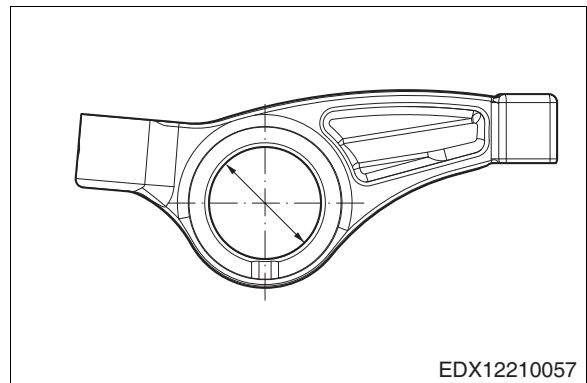

<Clearance>

(mm)

Standard	Limit
0.015 ~ 0.059	0.12

3) Tappet and pushrod



● Clearance

Measure the clearance between the tappet and tappet hole on the cylinder block. Replace the tappet if the value exceeds the specified limit.

(mm)

Standard	Limit
0.035 ~ 0.077	0.15



● Inspecting the tappet visually

Inspect the tappet surface in contact with the cam visually for pitting, scratches or cracks and replace if severely damaged. If the cracks or pitting are minor, use an oil stone or sandpaper to fix them.

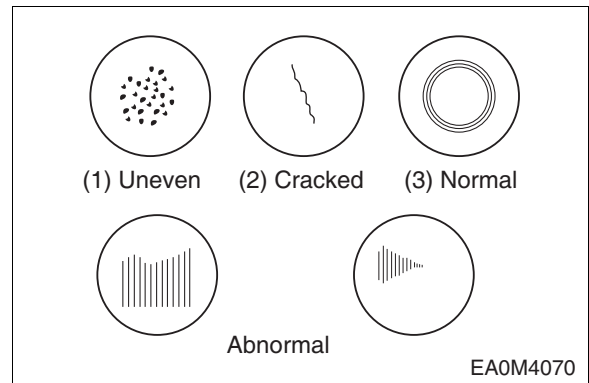

● Tappet O.D.

Use an outside micrometer to measure the outside diameter of the tappet. Replace the tappet if the measured value exceeds the limit.

(mm)

Tappet diameter	Ø19.944 ~ Ø19.965
-----------------	-------------------

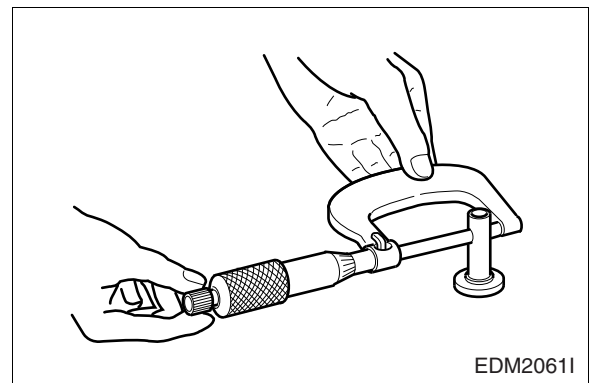

● Pushrod runout

(mm)

Limit	0.3 or less
-------	-------------

Use a feeler gauge to measure the pushrod runout.

Roll the pushrod over a smooth surface as shown in the picture.

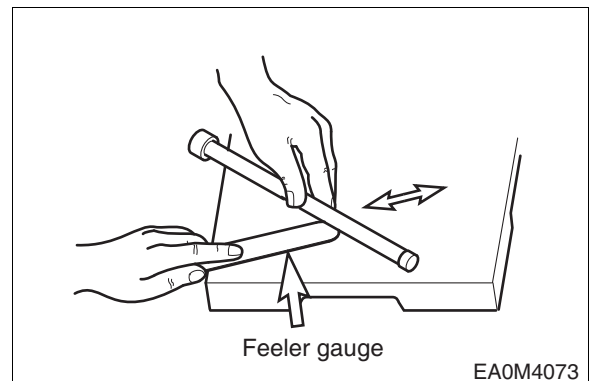

6.2.5. Camshaft

1) Cam



- Cam journal diameter and lobe height (mm)

		Standard	Limit
Cam journal diameter (A, B)		Ø59.86 ~ Ø59.88	Ø59.56
Cam lobe height (C)	Intake	50.27	49.97
	Exhaust	50.30	50.00

Use a micrometer to measure the cam journal diameter. The camshaft must be replaced if the measured value is lower than the specified limit.



- Cam surface
Use a micrometer to measure the cam journal diameter. The camshaft must be replaced if the measured value is lower than the specified limit. For minor layered wear or damage, use an oily grindstone or fine sandpaper to polish the surface. For severe damage, replace the cam.

2) Camshaft



- Clearance between the camshaft journal and camshaft bushing
 - Use an outside micrometer to measure the camshaft journal diameter.
 - Use a cylinder bore indicator to measure the inside diameter of the cylinder block camshaft bushing. Then, compare the measured value with the camshaft O.D. to check the clearance.

<Clearance> (mm)

Standard	Limit
0.045 ~ 0.100	0.2

Replace the bushing if the measured value exceeds the specified limit.

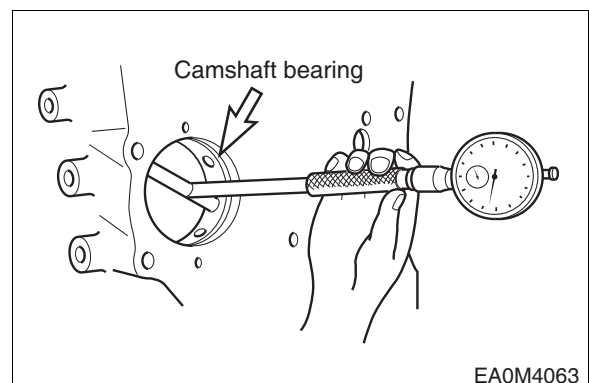
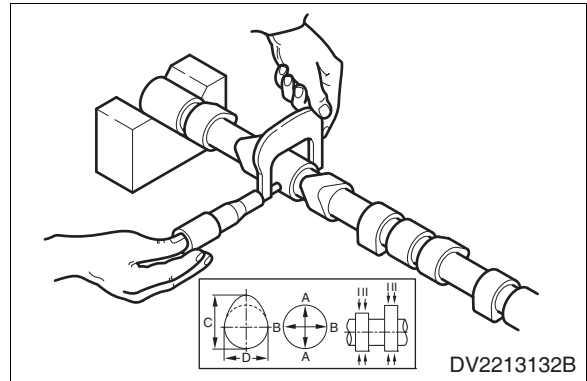



- Runout
Support the camshaft on two V-blocks and use a dial indicator to check the runout. If the measured value indicates that the runout exceeds the limit and requires maintenance, fix or replace the camshaft.

(mm)

Standard	Limit
0.05	0.15

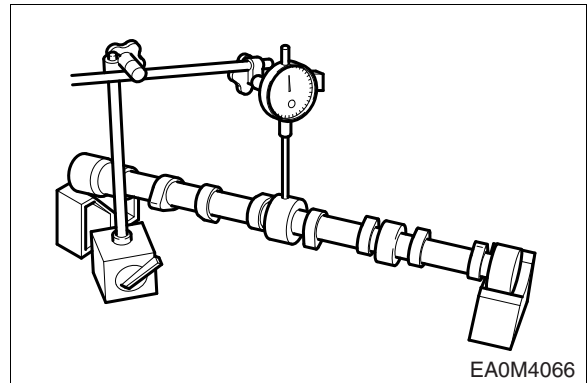

3) Camshaft and free play



- Push the thrust plate toward the cam gear.
- Use a feeler gauge to measure the clearance between the thrust plate and camshaft journal.
- If there is excessive end play, replace the thrust plate.

(mm)

Standard	Limit
0.14 ~ 0.25	0.5

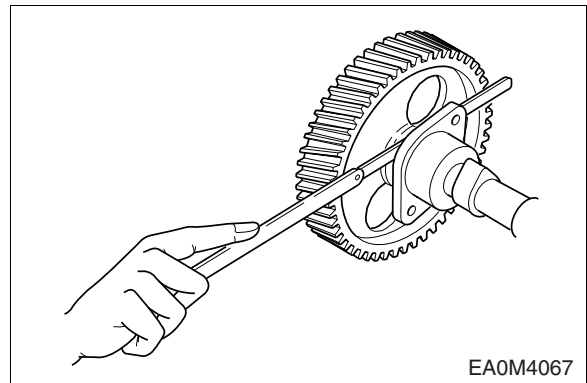

6.2.6. Crankshaft

1) Checking the exterior



- Visually inspect the crankshaft journal and crankpin for scratches or damage.
- Perform a magnetic particle test or liquid penetrant test (color check) to check for cracks in the crankshaft. Replace if cracked.

2) Measuring crankshaft wear



- Using a micrometer, measure the crankshaft journal and pin O.D. in the direction shown in the picture to check the amount of wear.

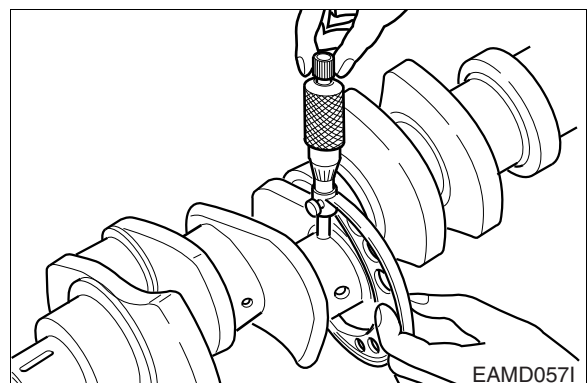

- If the wear amount exceeds the limit, polish the crankshaft and install an undersized bearing on it. However, if the wear does not exceed the limit, use an oil stone or fine sandpaper to correct the worn part and continue using it.
(Make sure the fine sandpaper has been soaked in oil.)

(mm)

Item	Standard	Limit
Journal diameter	Ø95.966 ~ Ø95.988	Ø94.966
Pin diameter	Ø85.966 ~ Ø85.988	Ø84.966

< Undersized bearings >

- Standard (STD)
- 0.25 (I.D. 0.25 mm smaller than standard)
- 0.50 (I.D. 0.50 mm smaller than standard)

Undersized bearings come in the two types above.

The crankshaft can be polished to the sizes above and reused.

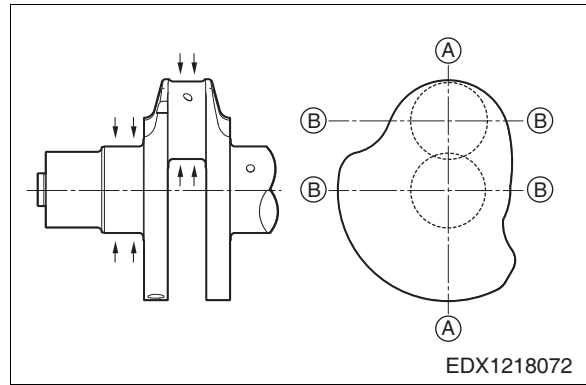

CAUTION

When polishing the crankshaft, the 'R' sections in the corners of the bearing must be polished precisely. Be sure to completely remove any bumps or rough spots.

- Standard "R" value
 - ① Crankshaft pin : 5.3 ~ 5.5 mm
 - ② Crankshaft main : 4.8 ~ 5.0 mm

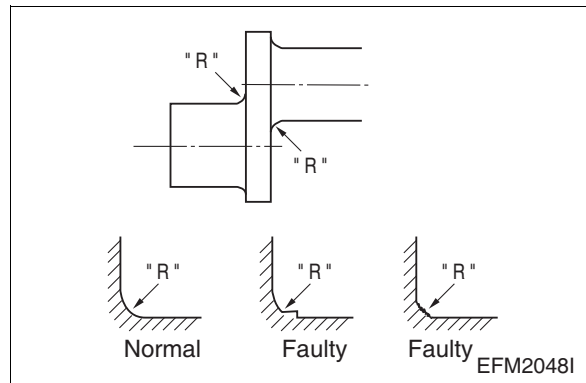

3) Crankshaft deflection



- Place the crankshaft on two V-blocks (#1, #7 main journal).
- Set a dial gauge on the surface plate and roll the crankshaft to measure its deflection.

No	Standard	Limit
4	0.1 mm	0.15 mm
3, 5	0.08 mm	0.12 mm
2, 6	0.05 mm	0.07 mm

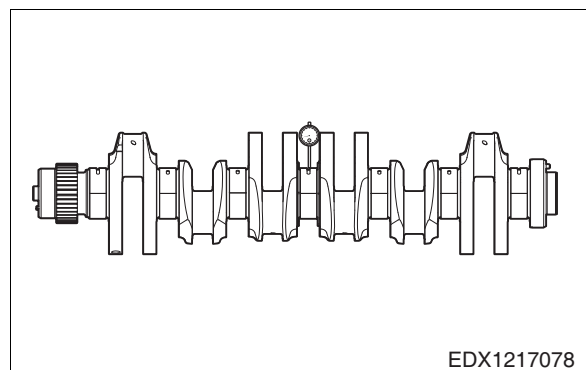

6.2.7. Crankshaft bearings and connecting rod bearings

- 1) Inspecting the exterior



Check the crankshaft bearings and connecting rod bearings visually for uneven wear, scratches or damage.

- 2) Oil clearance between crankshaft and main bearing



- **Main bearing clearance**
Install the main bearing on the cylinder block, tighten the bearing cap to the specified torque, and measure the inside diameter.



Torque	30 kg·m
--------	---------

Standard diameter	Ø96.06 ~ Ø96.108 mm
-------------------	---------------------

Compare the measured inside diameter of the main bearing with the outside diameter of the crankshaft journal to calculate the oil clearance between them.

< Main bearing oil clearance >

Standard	Limit
0.072 - 0.142 mm	0.200 mm



- **Connecting rod bearing clearance**
Install the connecting rod bearing on the connecting rod bearing cap, tighten the bolt to the specified tightening torque, and measure the inside diameter.



Torque	8 kg·m + 60°
--------	--------------

Standard diameter	Ø86.036 ~ Ø86.084 mm
-------------------	----------------------

Compare the measured inside diameter of the connecting rod bearing with the outside diameter of the crankpin to calculate the oil clearance between the two parts.

<Connecting rod bearing oil clearance>

Standard	Limit
0.048 - 0.118 mm	0.180 mm



- If this clearance is not within the specified limit, polish the crankshaft journal and pin. Select and use an undersized bearing suited to the size of the polished crankshaft.

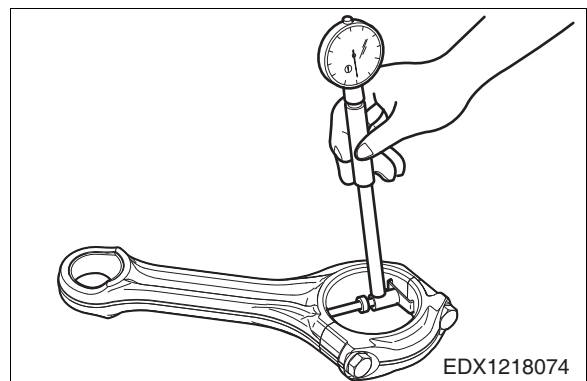
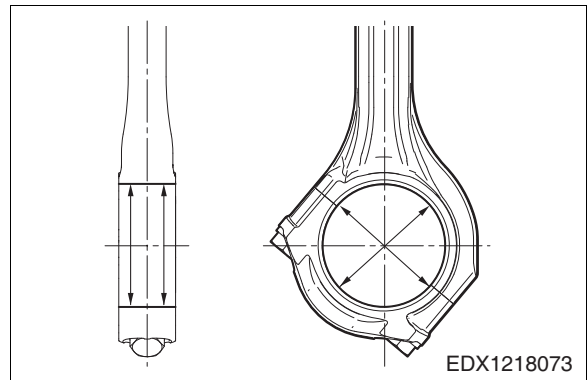
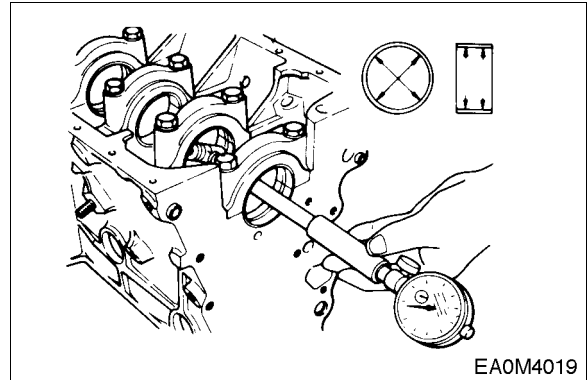

3) Bearing spread and crush



● Checking the exterior

When reassembling the bearing, check whether it needs to be pressed in firmly by hand (i.e. whether it is sufficiently flexible).

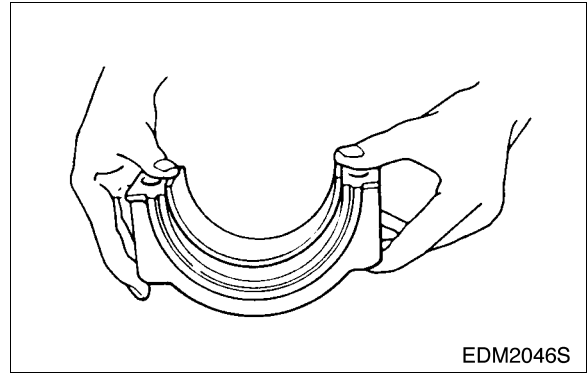

EDM2046S

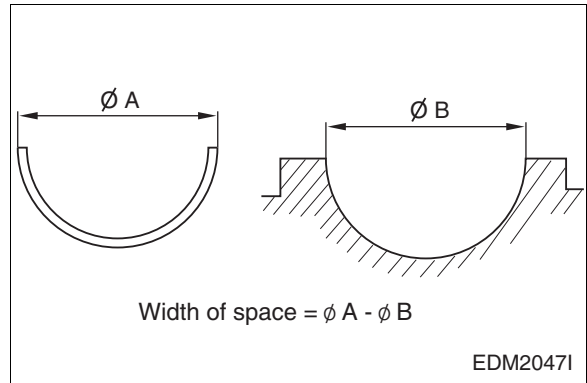

EDM2047I



● Crankshaft bearing crush

Install the bearing and cap on the cylinder head, tighten them to the specified torque, and unscrew the bolt on one side completely. Then, use a feeler gauge to measure the clearance between the cylinder block and bearing as shown in the picture.

Standard	0.16 - 0.24 mm
----------	----------------

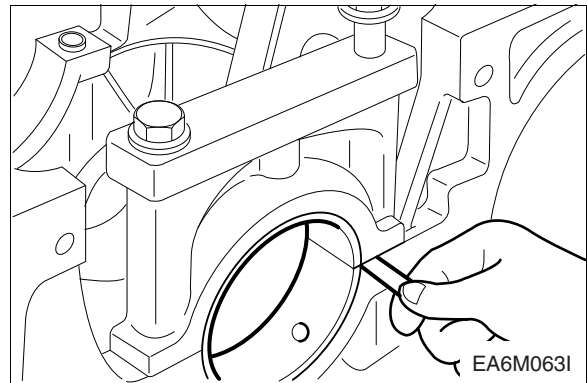

EA6M063I



● Connecting rod bearing crush

Install the bearing and cap on the connecting rod, tighten the bolts to the specified torque, and unscrew one of the bolts completely. Then, use a feeler gauge to measure the clearance between the bearing cap and connecting rod big end as shown in the picture.

Standard	0.17 - 0.25 mm
----------	----------------

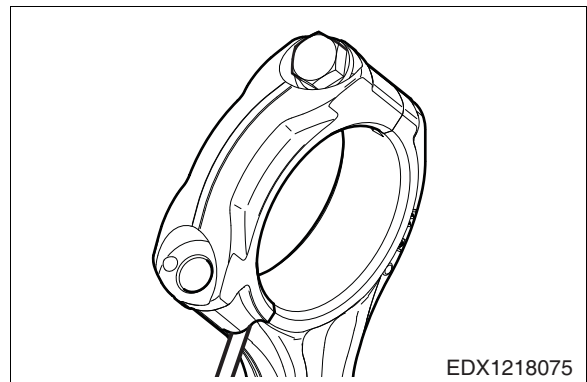

EDX121807S

- 4) Crankshaft end play
- Install the crankshaft in the cylinder block.
 - Use a dial gauge to measure the crankshaft end play.



Standard	0.1 - 0.3 mm
----------	--------------

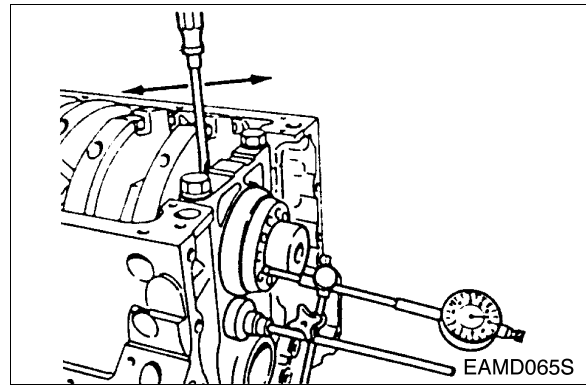

6.2.8. Pistons

- 1) Inspecting the exterior



Visually inspect the pistons for wear, cracks or scratches, checking the piston ring grooves with particular care.

- 2) Clearance between the piston and cylinder liner



- Use an outside micrometer at a right angle to the piston pin hole to measure the piston outside diameter in the places where the distance from the bottom part of the piston skirt is D1, D2 and D3.

Point	Standard diameter
D1 (25 mm)	$\text{Ø}122.870 \pm 0.007 \text{ mm}$
D2 (78.5 mm)	$\text{Ø}122.696 \pm 0.009 \text{ mm}$
D3 (122 mm)	$\text{Ø}120.593 \pm 0.015 \text{ mm}$

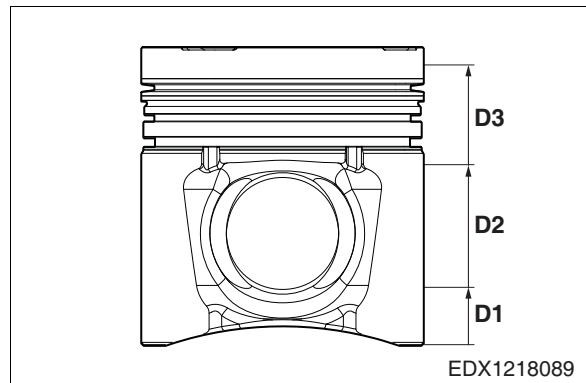

- Use a cylinder bore gauge to measure the inside diameter of the cylinder liner. Measure three places at 45° intervals: the top ring contact surface of the cylinder, the middle, and the bottom of the oil ring contact surface. Without the maximum and minimum values, calculate the average value with the remaining values.

Standard	Limit
$\text{Ø}123 \sim \text{Ø}123.025 \text{ mm}$	$\text{Ø}123.223 \text{ mm}$

- Subtract the piston outside diameter from the cylinder liner inside diameter to calculate the clearance. If this value exceeds the limit, replace either the piston or the cylinder liner (whichever is more worn).

<Clearance between the piston and liner>

Standard	0.123 - 0.162 mm
----------	------------------

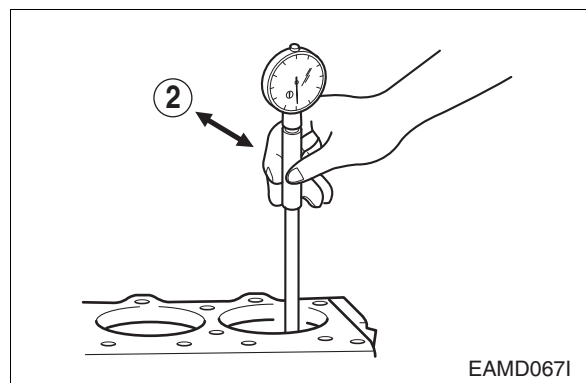

6.2.9. Piston ring



- 1) Inspecting the exterior
If the piston ring is worn or damaged when disassembling the engine, replace it with a new one.



- 2) Piston ring clearance
 - Insert the piston ring into the top of the cylinder liner so that it is set at a right angle to the liner wall.
 - Use a feeler gauge to measure the piston ring clearance.
 - If the clearance exceeds the limit, replace the piston ring.

(mm)

Dimensions Description	Standard	Limit
Top ring	0.3 ~ 0.45	0.7
Second ring	1.0 ~ 1.2	1.45
Oil ring	0.3 ~ 0.45	0.7

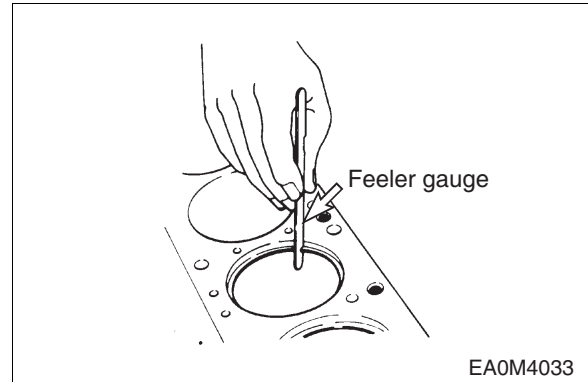

- 3) Piston ring groove clearance



- Install the compression ring and oil ring in the ring groove of the piston.
- Use a feeler gauge to measure the clearance between each ring and the width of the groove. If the measured value exceeds the limit, replace the ring or piston.

(mm)

Dimensions Description	Standard	Limit
Top ring	-	-
Second ring	Ø0.07 ~ Ø0.105	Ø0.125
Oil ring	Ø0.05 ~ Ø0.09	Ø0.11

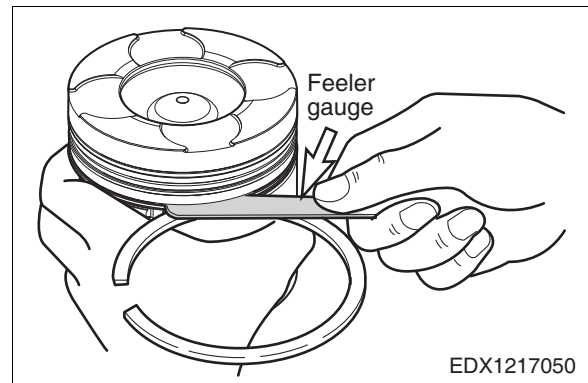

- 4) Piston ring tension



- Use a tension tester to measure the tension of the piston ring. If the value exceeds the limit, replace the piston ring.

Item	Standard
Top ring	2.4 ~ 3.5 kg
Second ring	2.0 ~ 2.9 kg
Oil ring	6.3 ~ 7.7 kg

6.2.10. Piston pins

1) Wear



Check the wear on the piston pins in the places shown in the picture. If this measured value exceeds the usable limit (0.005 mm or higher), replace the pin.

Standard	Limit
Ø48.995 ~ Ø49.000 mm	Ø48.990 mm or less

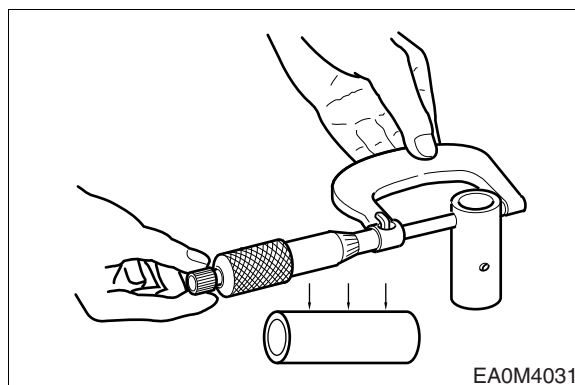

2) Clearance



Measure the clearance between the piston pin (1) and connecting rod bushing (2). If this value exceeds the usable limit, replace whichever part is more worn.

Standard	Limit
0.050 ~ 0.080 mm	0.12 mm

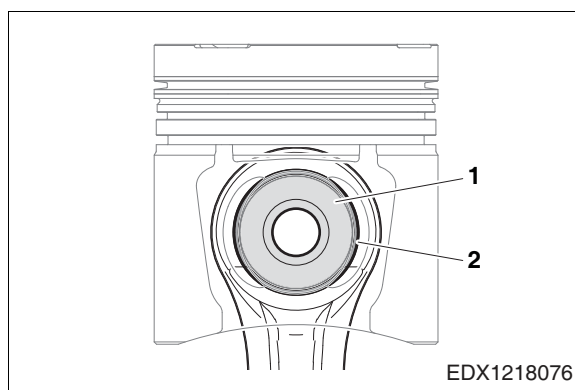

3) Inspecting the assembly



The piston is normal if the piston pin can be inserted into the pin hole after heating the piston with a piston heater.



When replacing the piston, the piston pin must also be replaced.

6.2.11. Connecting rods

1) Distortion



Install the connecting rod on the connecting rod tester as shown in the picture.

Then, use a feeler gauge to measure the distortion.

If the connecting rod is distorted, do not attempt to correct and reuse it. Be sure to replace it with a new one.

2) Hole alignment (parallelism)



Check the parallelism of the piston ring bushing hole at the small end and the bearing groove at the big end of the connecting rod. Install it on a connecting rod tester and measure it with a feeler gauge as described above.

Standard	Limit
0.1875 mm	0.2 mm or less

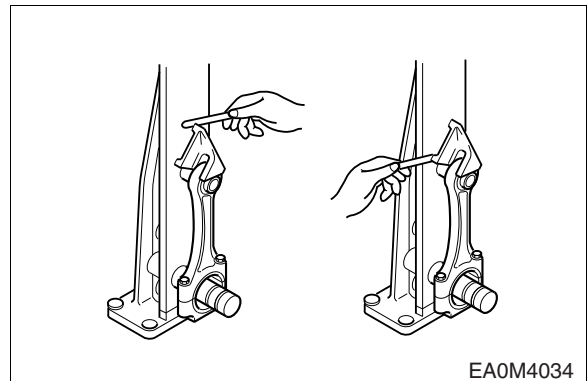

3) Wear



- Install the connecting rod on the crankshaft and use a feeler gauge to measure the clearance between the parts at the big end of the connecting rod.
- Install the piston ring on the connecting rod and measure the clearance between the parts at the small end of the connecting rod.
- If the measured value exceeds the limit, replace the connecting rod.

Limit	0.011 mm
-------	----------

6.3. Engine Reassembly

6.3.1. General Precautions

- Clean all disassembled parts thoroughly. In particular, clean the inside of oil and coolant passages thoroughly using compressed air and check for any foreign matter.
- Arrange the various special and regular tools for assembly in order of engine assembly.
- Prepare clean engine oil to be applied to each sliding section.
- Prepare replacement parts for consumables such as sealant and gaskets.
- Discard all used gaskets, seal rings and consumables. Replace them with new ones.
- Tighten the various bolts to the specified tightening torque according to the tightening order. Never overtighten bolts.
- After reassembly, check to ensure that all sliding parts are working smoothly.
- After assembly is completely, be sure to check whether any bolts are loose or insufficiently tightened.
- After completely assembling the engine, check for any missing or faulty parts.
- All work must be performed with clean hands.

6.3.2. Cylinder Block

- Lay wooden boards or thick cardboard on the ground so as not to damage the cylinder head assembly surface. Then, place the cylinder block on them with the head mounting surface facing the ground.

6.3.3. Oil injection nozzle



- Use an injection nozzle assembly jig to tighten and assemble the oil injection nozzle flanges with mounting bolts.

Torque	3.1 ±0.3 kg·m
--------	---------------

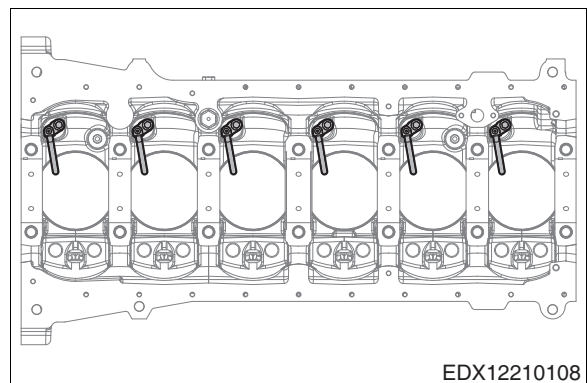

6.3.4. Tappets and camshaft



- Cool the new camshaft bushing in dry ice for approx. two hours. Then, use a bench press to press-fit it into the cylinder block. After press-fitting the bushing, measure the inside diameter to check for any deformation.



- Apply oil to the front of the tappets and insert them into the tappet holes on the cylinder block.

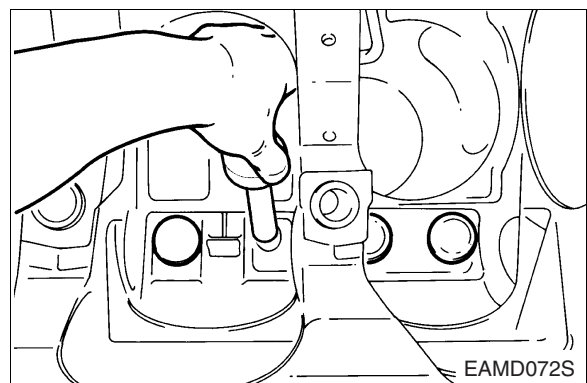



- Apply oil to the inside diameter of the cam bushing and camshaft, then assemble these parts carefully while turning the camshaft.



- Check whether the camshaft rotates smoothly.

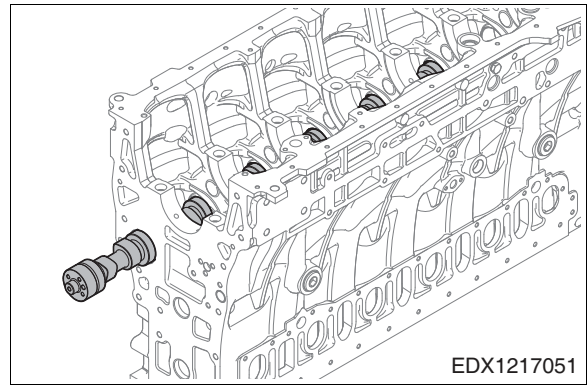

6.3.5. Crankshaft



- Assemble the main bearings, aligning the key groove of the cylinder block and the key groove of the bearing with the two main bearing holes drilled into the cylinder block. Then, apply oil to the bearing surface.

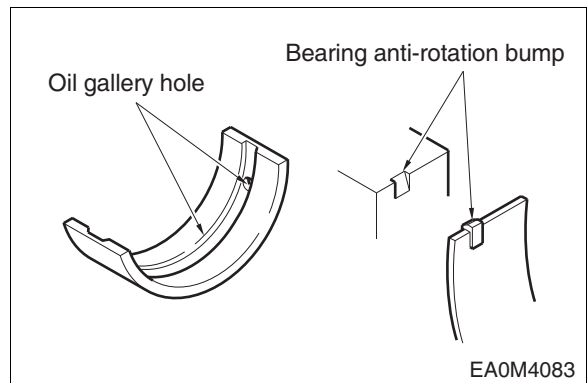

- Before assembling the crankshaft, heat the crankshaft gear at 120 °C for 10 minutes. Then, apply an even layer of sealant (Loctite #641) to the inside of the gear and assemble it.

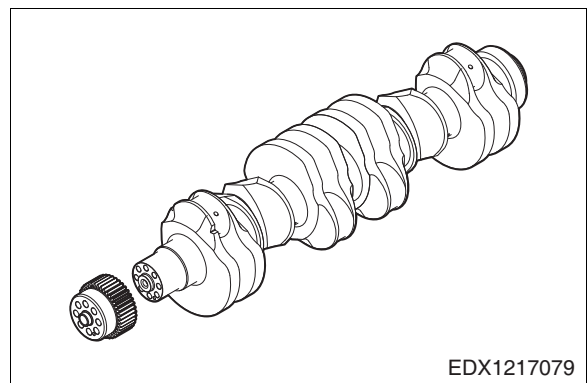

- Temporarily assemble one bolt at a time on both ends of the crankshaft, raise the crankshaft, and apply oil to the journal and pin. Then, assemble it with the cylinder block.

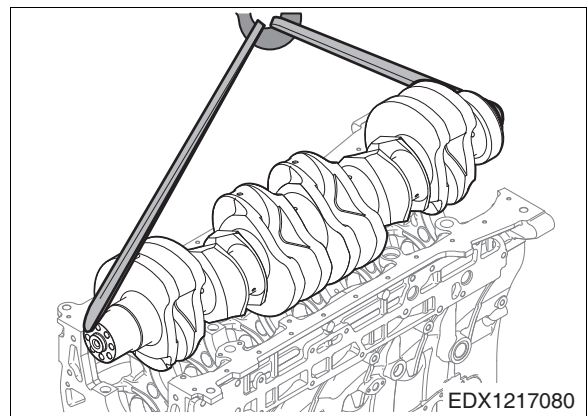



- Assemble the oil-coated thrust washers so that the oil groove in the washers faces the opposite side of the bearings as shown in the picture.

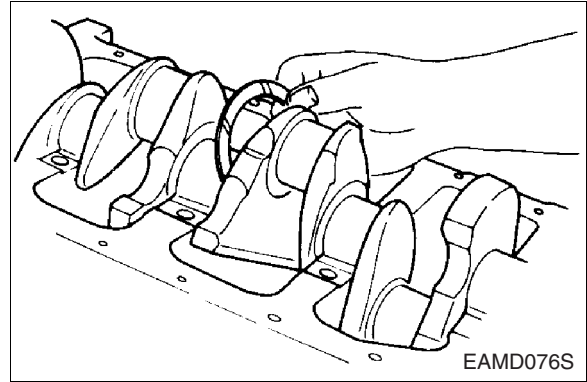

- Assemble the bearings and thrust washers with the bearing caps, then apply oil.

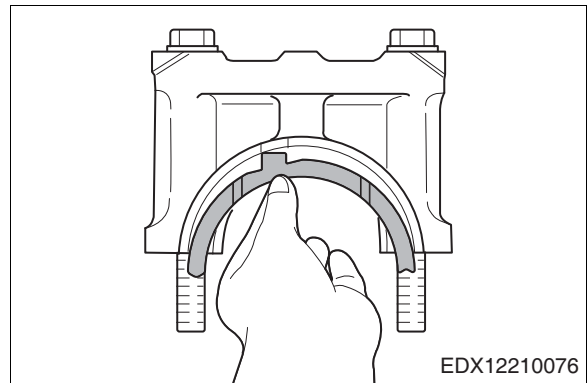

- Install the bearing caps, aligning the numbers on the bearing caps with the numbers engraved on the cylinder block.

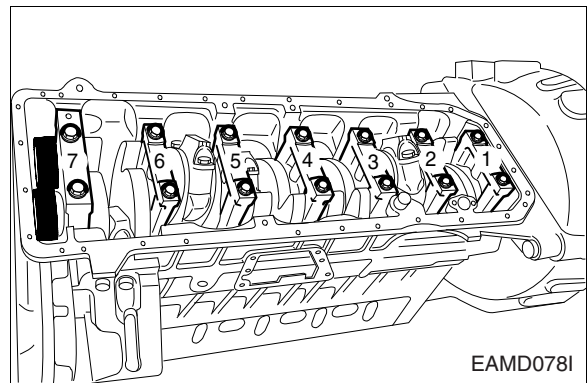

- Apply oil to the front of the bearing cap bolts and tighten them to the specified torque according to the tightening order.



Torque	30 kg·m
--------	---------



- After temporarily tightening the bolts on both sides of the bearing caps evenly, tighten the bearing cap bolts sequentially in a diagonal line to approx. 15 kg·m first. Then, tighten them to 25 kg·m, and finally, tighten each bolt to the specified tightening torque of 30 kg·m.

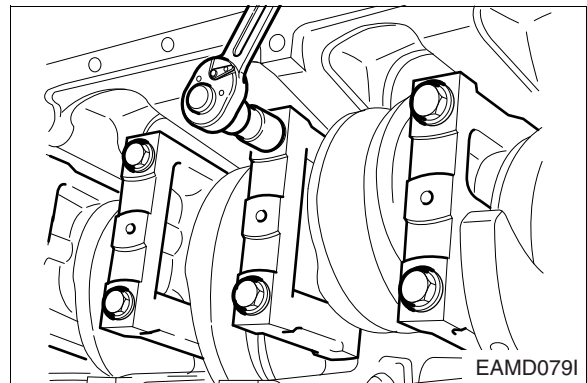

- Tighten the bearing caps in the order 4-3-5-2-6-1-7.



- After tightening the bearing cap bolts, check whether the crankshaft rotates smoothly.

6.3.6. Flywheel housing

- Temporarily install the support rod on the cylinder block for removing the housing.
- Install the gasket on the cylinder block.
- Use the offset pin and support rod to attach the flywheel housing. Then, tighten the diagonal row of mounting bolts to the specified tightening torque in order.



Torque	12 kg·m
--------	---------

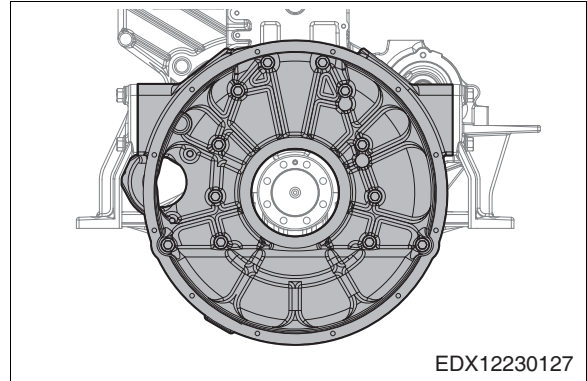

6.3.7. Rear Oil Seal



- Apply oil to the outer surface of the oil seal and the inside diameter of the flywheel housing. Then, assemble them with the crankshaft and use an assembly jig to assemble the oil seal.

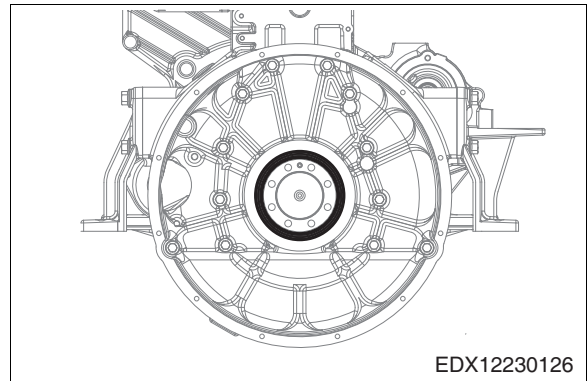

6.3.8. Flywheel



- Install a support rod in a crankshaft bolt hole, then lift the flywheel to align it with the offset pin and assemble it temporarily.
- After assembling a bolt in a bolt hole without the support rod installed, remove the support rod and assemble the remaining bolts in these holes.



- Use a torque wrench to tighten the bolts sequentially to the specified torque in a diagonal line.

Torque	18 - 22 kg·m
--------	--------------

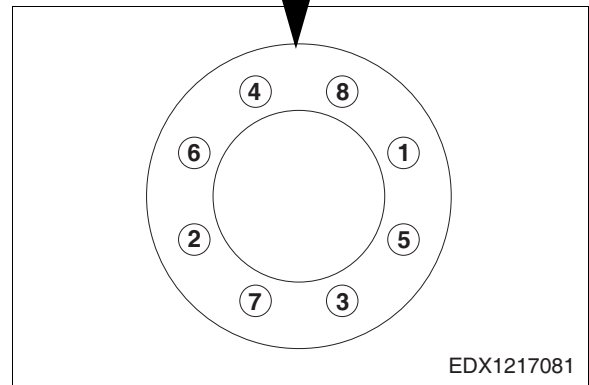
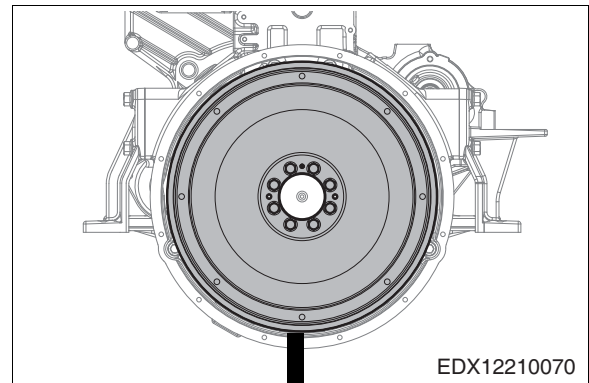

6.3.9. Timing gear case



- Use parallel pins to mount the gasket on the cylinder block.
- Align the dowel pins with the dowel pin holes in the timing gear case and install the timing gear case.
- Tighten the bolts to the specified torque.

Torque	11.2 ±1.1 kg·m
--------	----------------

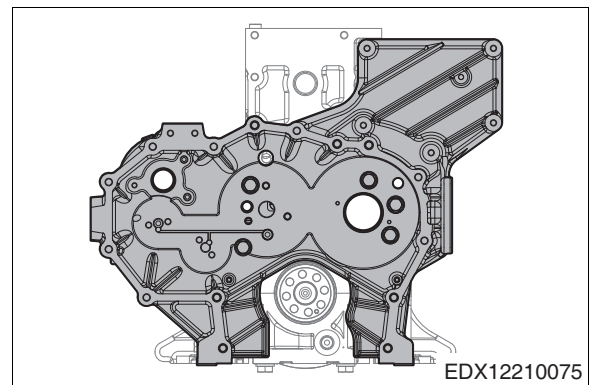

6.3.10. Timing gear

- Install the oil pump idler gear in bearing cap no.1.



- Install the thrust washers on the camshaft, then assemble the cam gears, aligning them with the camshaft key groove.

Camshaft thrust washers	0.9 kg·m
Camshaft gear mounting bolts	3.1 kg·m

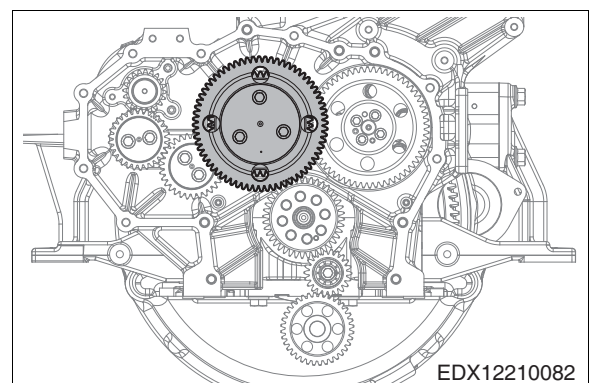



- Install high-pressure fuel pump idler gear B (one marked groove).
- Install the high-pressure fuel pump drive gear assembly.
- Install high-pressure fuel pump idler gear A (two marked grooves).
- Install the idler gear pin so that the oil port on the idler pin faces the cylinder block.



- Assemble the idler gears while aligning the markings on the crank gear, cam gear, high-pressure fuel pump drive gear and idler gear.

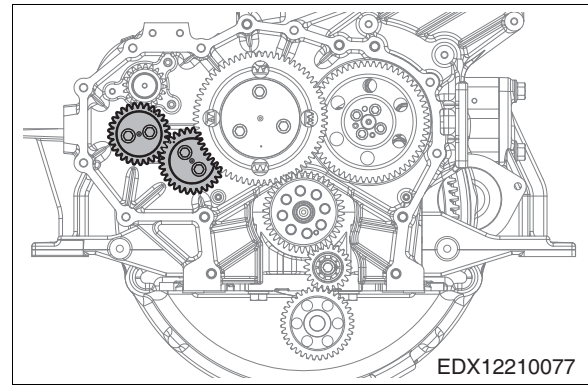

Description	Torque
High-pressure fuel pump Idler gears A and B	6.2 kg·m
Step idler gear	
Air compressor Idler gear	



- Use a feeler gauge to measure and adjust the amount of backlash between gears.

(mm)

Measuring location (between)	Backlash
Crank gear and oil pump idler gear	0.060 ~ 0.184
Oil pump idler gear and oil pump gear	0.020 ~ 0.292
Crank gear and idle gear A	0.062 ~ 0.194
Idler gear B and Camshaft gear	0.090 ~ 0.236
Idler gear B and high- pressure fuel pump idler gear B	0.072 ~ 0.189
High-pressure fuel pump idler gear B and high- pressure fuel pump idler gear A	0.071 ~ 0.191

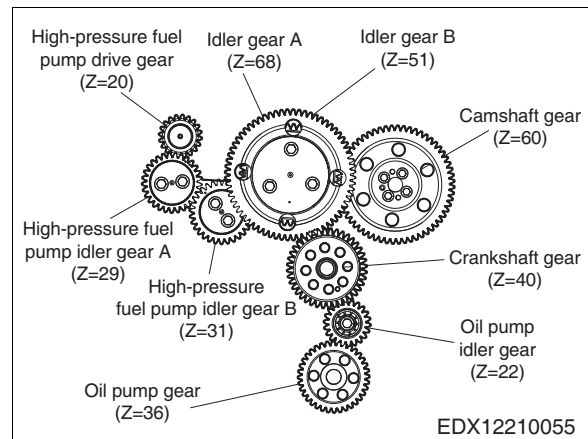

6.3.11. Timing Gear Case Cover

- Install the parallel pins on top of the timing gear case.
- Mount the gasket while aligning the mounting bolt holes and gasket holes.
- After aligning the cover pin holes with the parallel pins, tap the cover lightly to install it.
- Tighten the mounting bolts starting from the oil pan mounting surface.

Torque	11.2 ±1.1 kg·m
--------	----------------

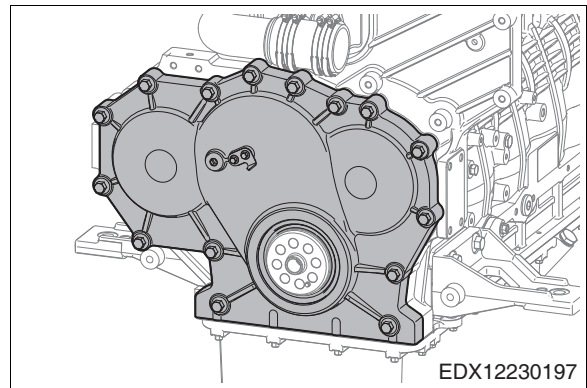

6.3.12. Front oil seal



- Apply oil to the outer surface of the oil seal and the inside diameter of the timing gear case. Insert them into the top of the crankshaft to assemble them, then use an oil seal assembly jig to assemble the oil seal.

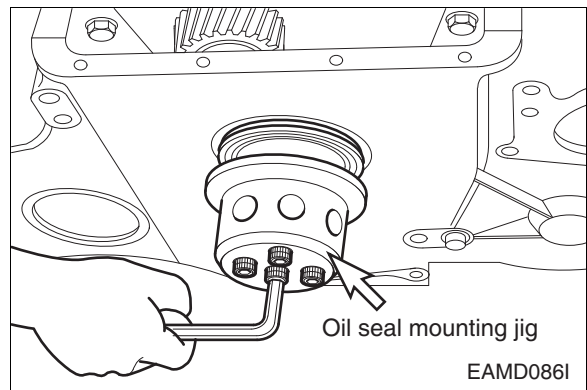

6.3.13. Cylinder liner

- Position the cylinder block so that the flywheel surface faces downwards.
- Use compressed air to thoroughly clean the inside of the hole on the cylinder block and the liner flange assembly surface with which the liner will be assembled.
- After cleaning and drying the liner, insert it into the cylinder block by hand.



- Apply engine oil to the inside surface of the assembled liner.

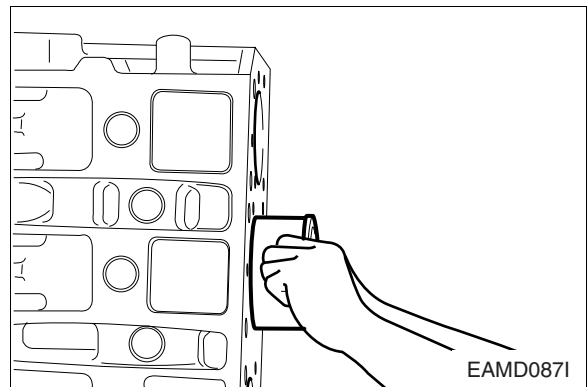

6.3.14. Pistons and connecting rods



- Heat the piston in a heater to approx. 100 °C for five minutes.

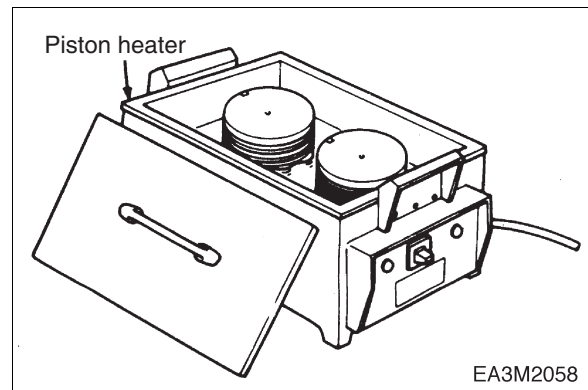

- Align the oil-coated small end bushing of the connecting rod with the piston pin hole, then tap the piston pin lightly with a rubber hammer to assemble the connecting rod and piston.

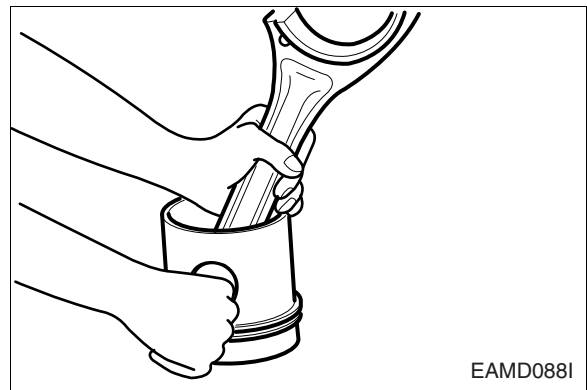

- Assemble the longer part of the connecting rod big end (the part with the groove in the bearing key) with the HD Hyundai Infracore logo engraved on the inside of the piston so that they face the opposite directions, taking care not to change the direction of the piston. As shown in the picture, the valve seat surface on the piston head should face the opposite direction of the longer part of the connecting rod. When seen from the top of the piston, it should face the same direction as the narrow clearance part of the combustion chamber.

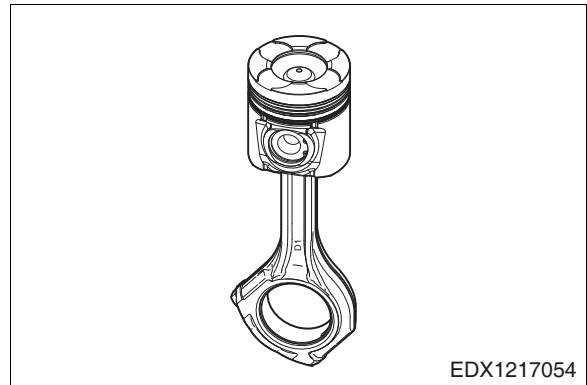

- Install the snap ring, making sure to check that it has been installed properly.



- Use piston ring assembly pliers to install the piston ring on the piston.



- Check the "Y" or "TOP" marking at the end of the ring to make sure that the direction of the piston ring is not switched around.



It must be installed so that the marking faces upwards.

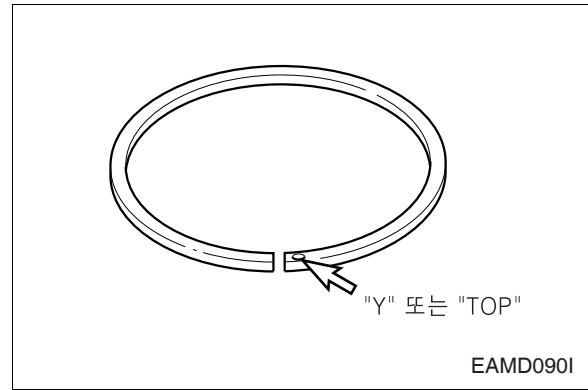

- Adjust the angle between each piston ring gap to 90°, then fit the piston into the piston assembly jig. When doing so, take care to ensure that the positions of the piston ring gaps do not align with the direction of the pins.



- Assemble the bearing, aligning it with the connecting rod key groove, then apply oil to the assembled bearing and piston.
- Push the piston in by hand, ensuring that the valve seat surface faces the tappet hole. Take care not to damage the cylinder liner and piston. Lift them slightly while inserting them in order to avoid damaging the ring on the raised part of the liner in particular.

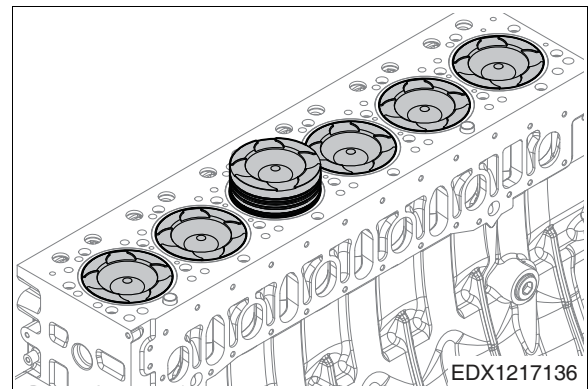
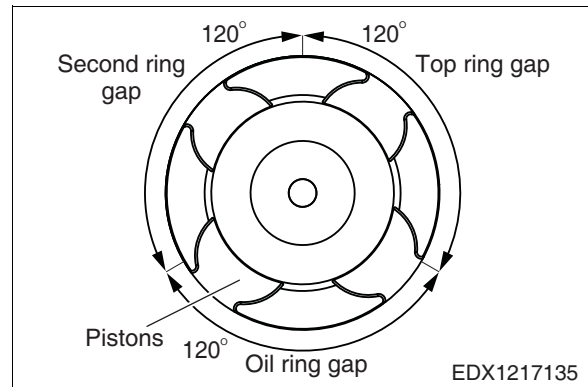

- Assemble the bearing with the connecting rod cap and apply oil to it.



- Check whether the numbers engraved on the connecting rod cap and the side of the big end are identical. Then, install the connecting rod cap, aligning it with the offset pin.



- After temporarily tightening the mounting bolts by hand, tighten them once to 8 kg-m; then, tighten them at 60° (0° ~ 10°).

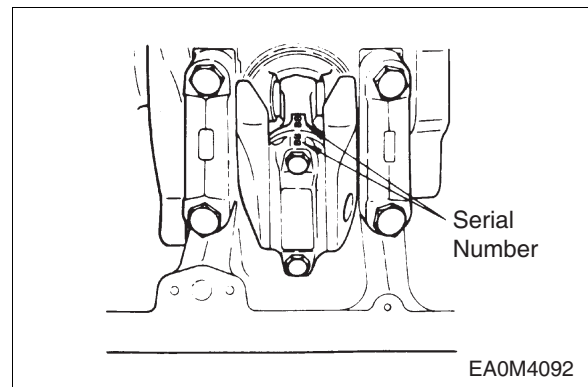



- Try moving the bearing cap by hand. If it is immobile, unscrew the mounting bolts and reassemble them.

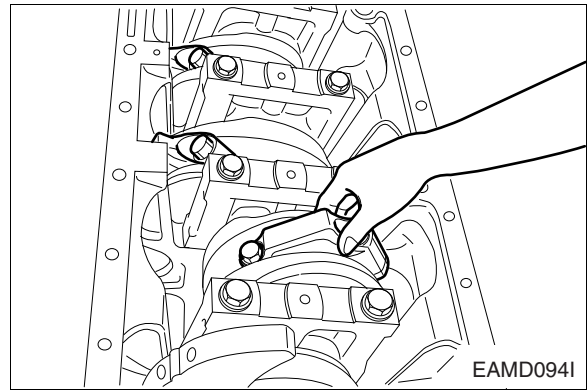

6.3.15. Relief valve

- Assemble the relief valve.

Torque	9 ±0.9 kg·m
--------	-------------

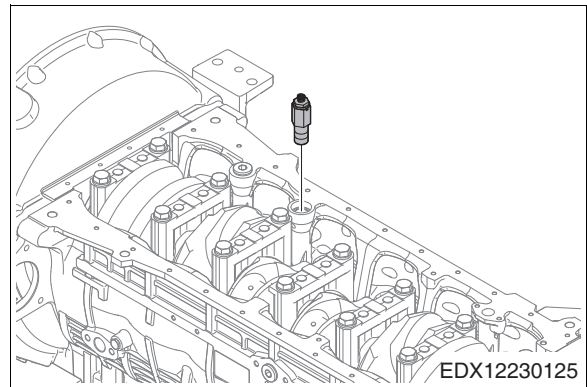

6.3.16. Oil Pump and Oil Pipe



- Assemble the offset pin with bearing cap no.7. Then, tighten the oil pump to the specified torque.

Torque	4.4 kg·m
--------	----------

- Connect the oil suction pipe and supply pipe. Then, assemble the support bracket with the bearing cap.

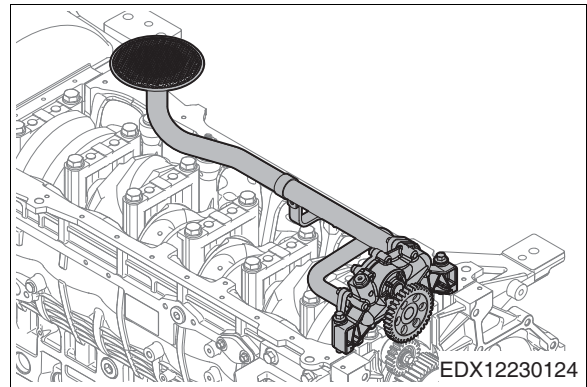

6.3.17. Oil pan

- Install the gasket and place the oil pan on top of it.



- Align the bolt holes and gasket holes without damaging the gasket. Then, tighten the bolts to the specified tightening torque.

Torque	3.1 kg·m
--------	----------

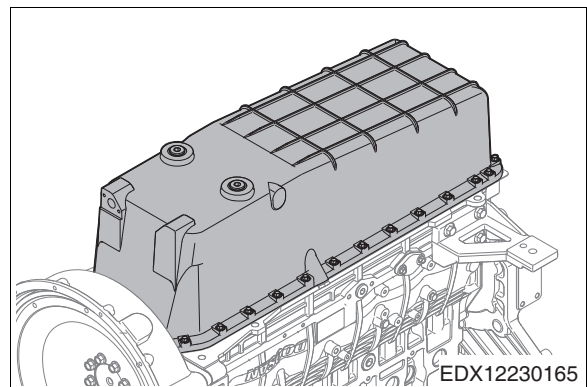

6.3.18. Intake/Exhaust Valves



- Before assembling the valves and valve heads, find the "N (IN)" and "X (EX)" marks on the valve heads.



- Use a valve stem seal mounting jig to assemble the valve stem seals and valve guides.

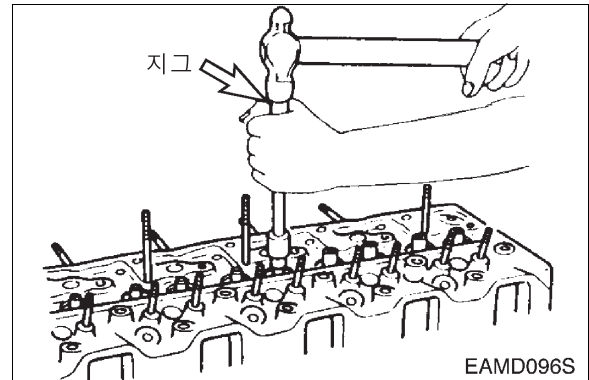

- After installing the valve springs and spring retainers, use the jig to press down on the retainers; then, install the cotter pins.



- Tap on the valve stems gently with a rubber hammer to check whether the valves have been assembled correctly.

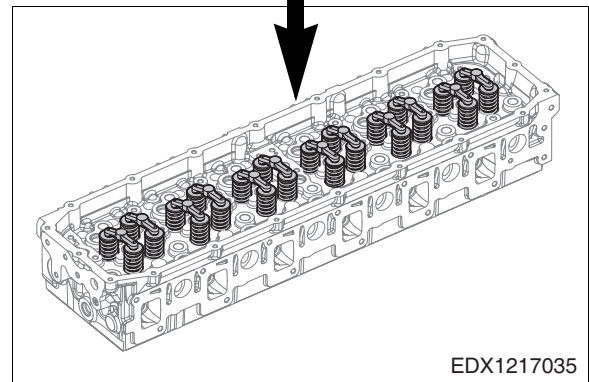

6.3.19. Injector



- Clean all parts thoroughly, taking care not to contaminate them with foreign matter.
- Fuel lines connecting the common rail to the injectors require particular cleanliness as they lack a filtration function.
- Clean and remove all foreign matter from the holes drilled in the cylinder head for inserting high-pressure fuel connectors and holes for injectors.
- When the injector is disassembled, the high-pressure fuel connector must be replaced with a new one.
- In the event that fuel accumulated in the fuel return line enters the combustion chamber while disassembling the injector, it must either be sucked out using a hand pump or discharged by cranking the starter motor with the fuel shut off.

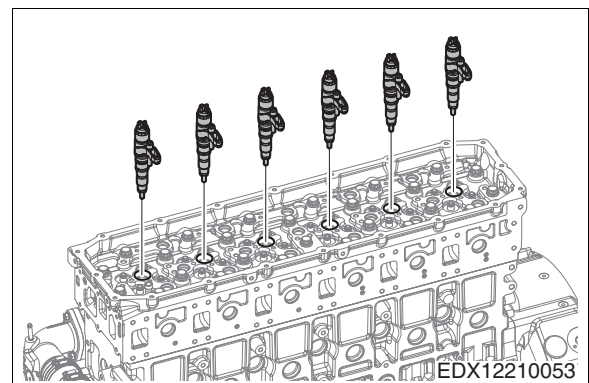

**CAUTION:**

When installing a new high-pressure fuel pipe after disconnecting the high-pressure fuel pipe connected to a high-pressure fuel connector (HPC), make sure to retighten the HPC mounting nuts to the specified torque. In addition, do not reuse high-pressure fuel pipes as the seal for high-pressure fuel is deformed while tightening them.

HPC nut Tightening torque	Temporary tightening: 0.3 ±0.1 kg·m
	Final tightening: 5.3 ±0.3 kg·m
High-pressure fuel pipe Tightening torque	4.0 ±0.4 kg·m

<Injector assembly order>

- 1) The injectors must be assembled precisely in the following order.

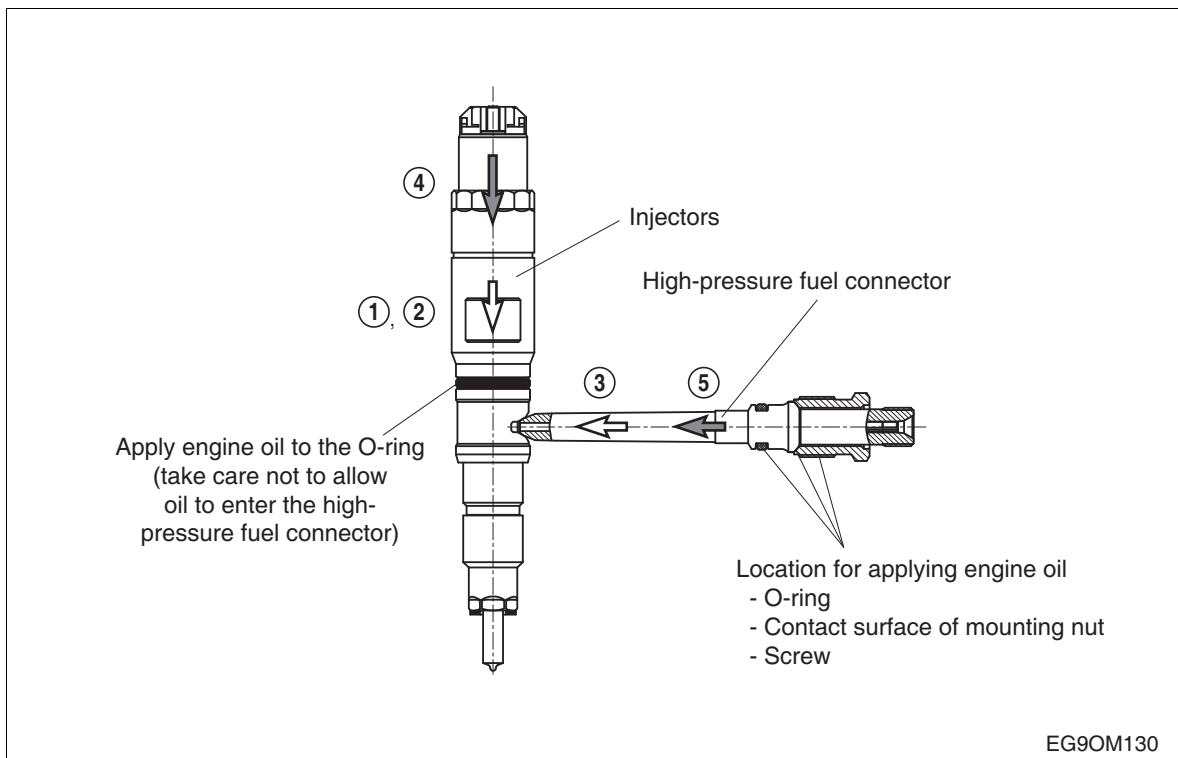

- 2) Fit an O-ring onto the injector and apply engine oil to the outer circumference. Be careful not to contaminate the connection hole in the high-pressure fuel connector on the side of the injector with water or foreign matter at this time.



- 3) Insert the injector carefully after aligning the seal ring with the injector hole in the cylinder head. Align the injector mounting bolt with the threaded section on the head and turn the bolt two to three threads by hand to tighten it.

- 4) Seat the injector in the mounting position on injector mounting brackets ① and ② using the mounting bolts; then, tighten it temporarily. After tightening the injector temporarily, loosen the mounting bracket bolts enough to allow it to move without applying excessive force to the injector. (Injector axial load of 0 kg·m)



- 5) Hold the ball on high-pressure fuel connector ③ in the vertical position and check that it is aligned with the groove in the hole on the side of the head of the intake manifold; then, align it with the high-pressure fuel connector using the hole in the side of the head and push the high-pressure fuel connector in as far as possible. After tightening the mounting nut (M22 × 1.5) on the high-pressure fuel connector two to three threads by hand, use a torque wrench to tighten it temporarily.

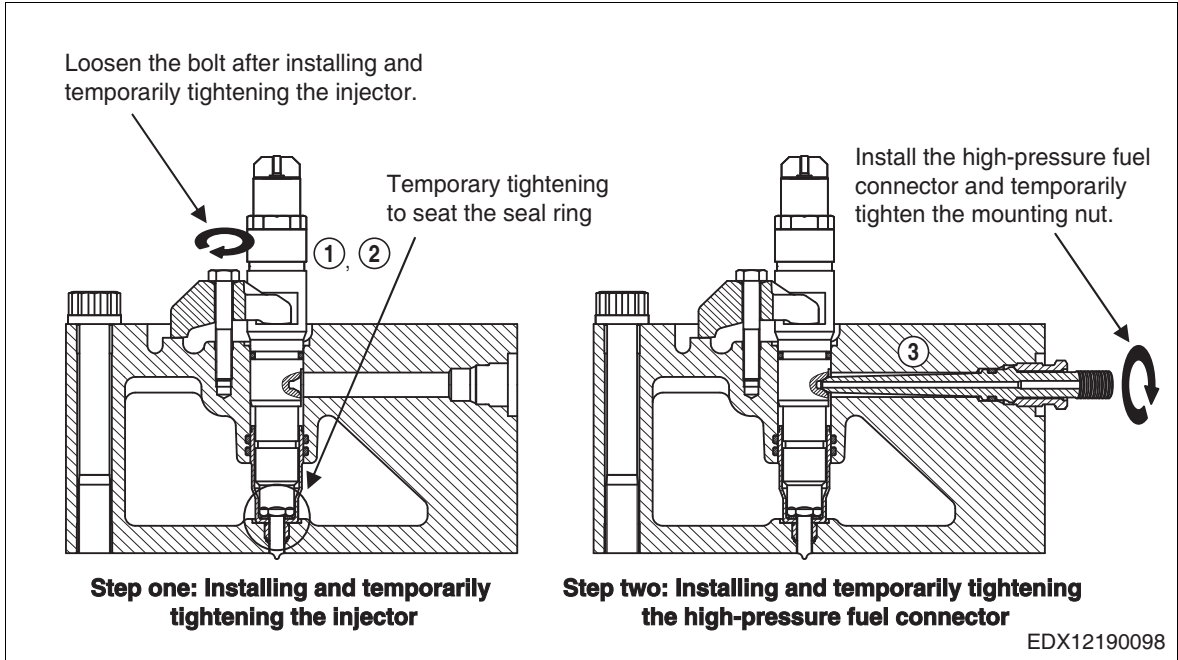

Temporary tightening torque	Injector mounting bracket bolt	High-pressure fuel connector mounting nut
	0.3 kg·m	0.3 kg·m

- 6) Finish tightening injector mounting bracket mounting bolt ④ and high-pressure fuel connector mounting nut ⑤ to their specified torque in order.

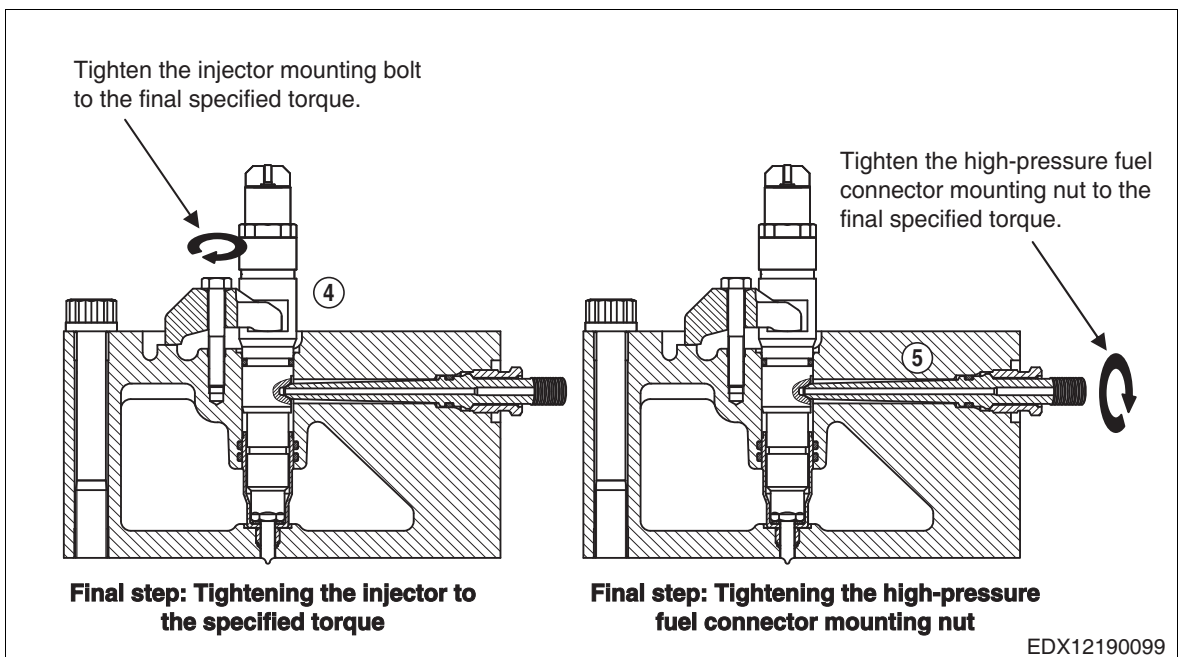

Final torque	Injector mounting bracket bolt	High-pressure fuel connector mounting nut
	3.8 ±0.4 kg·m	5.3 ±0.3 kg·m

6.3.20. Cylinder Head

- Install the injection nozzle mounting stud bolts and coolant pipe mounting stud bolts.



- Remove any foreign matter from the head bolt hole on top of the cylinder block using compressed air. Then, wipe the cylinder block surface with which the head gasket will be assembled thoroughly.



- Make sure that the head gasket faces upwards and assemble the gasket, aligning it with the retaining pin on the cylinder block.

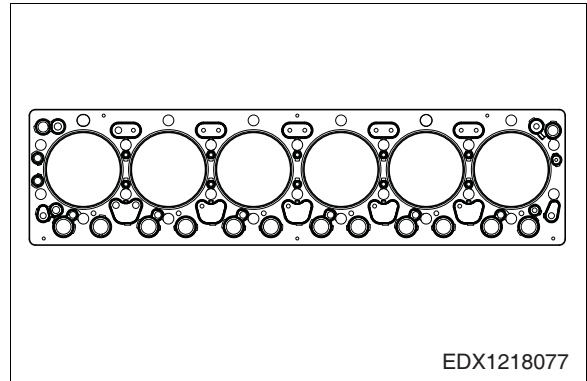

- Check for any foreign matter in the combustion chamber. Then, mount the cylinder head by aligning it with the offset pin.
- Be careful not to damage the gasket. If the pin hole is not aligned, lift the cylinder head and put it down again.
- When removing the cylinder head bolts after installation, replace the gasket with a new one.

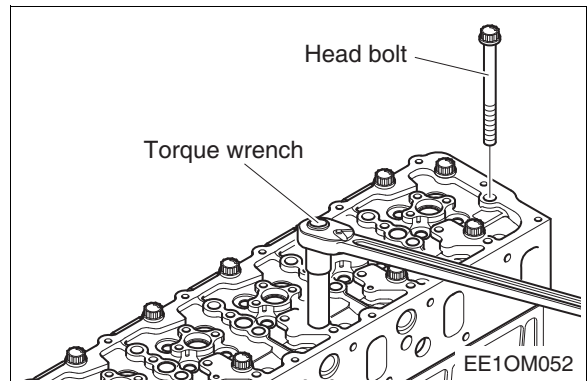

- Assemble at the specified tightening torque in the correct order of assembly.

<Cylinder head bolts>

Type 5 (10.9T)	
Specifications	 M16×1.5×161
Torque	1st tightening: 6 kg×m 2nd tightening: 90° + 90° Final tightening: 30°

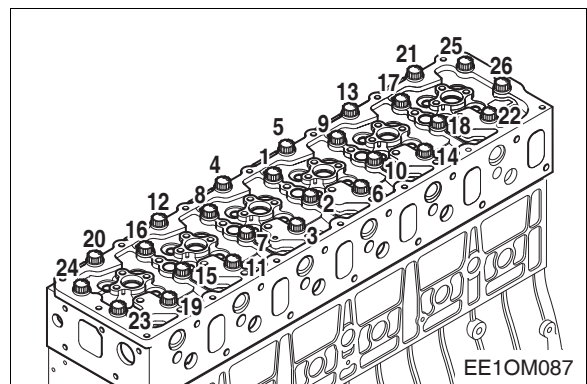



- Adjust the valve clearance according to the following procedure and clearance adjustment method.

<Valve clearance adjustment guide>



- Turn the crankshaft to set the piston of cylinder no. 1 at TDC of the compression stroke; then, adjust the valve clearance. (Cylinder no. 1 starts at the front of the engine while cylinder no. 6 starts at the rear where the flywheel is mounted.)



- Unscrew the rocker arm mounting nut and fit the feeler gauge between the rocker arm and valve. Adjust each clearance with the adjusting screw, then tighten the mounting nut.
- Adjust the valve clearance as follows when the engine is cold:

Reference value	
Intake valve	Exhaust Valve
0.4 mm	0.7 mm

< Valve clearance adjustment method no.1 >

- After turning the crankshaft to align cylinder no.1 with the TDC position, adjust the valve in position "O" in the following picture. At this time, cylinder no.1 must be in the TDC position of the ignition stroke (O.T.).

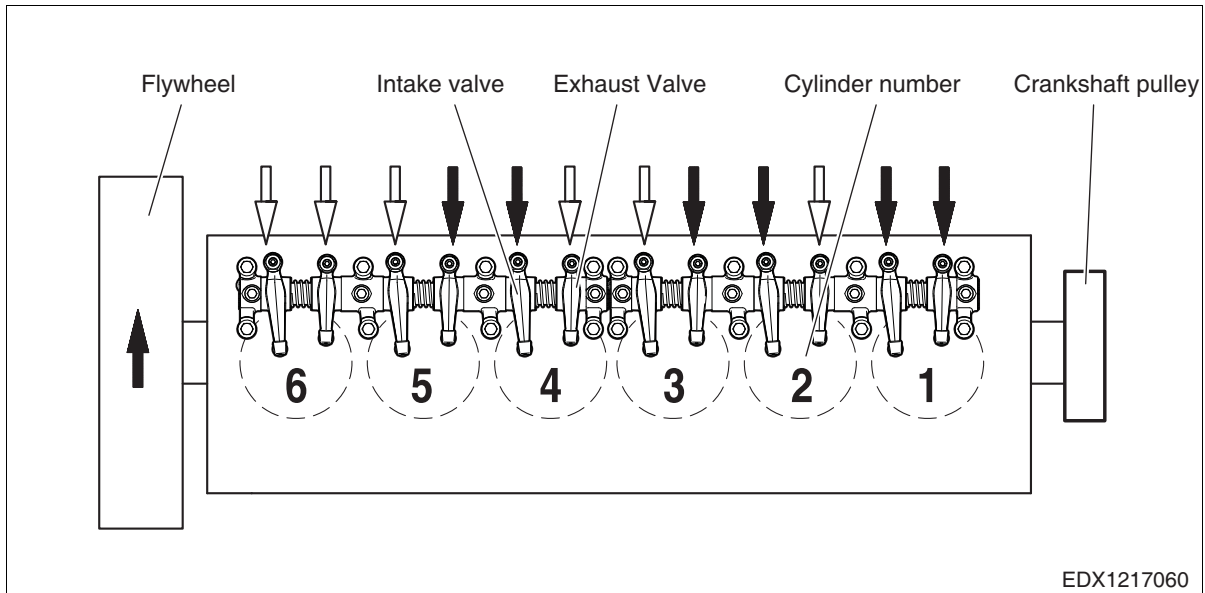

Cylinder number	1		2		3		4		5		6	
	Exhaust	Intake	Exhaust	Intake	Exhaust	Intake	Exhaust	Intake	Exhaust	Intake	Exhaust	Intake
Cylinder #1 TDC (Cylinder #6 valve overlap)	●	●		●	●			●	●			
Rotate 360°			●			●	●			●	●	●

< Valve clearance adjustment method no.2 >

- Valve adjustments for the valve overlap of each cylinder are to be performed as follows.

Valve overlap of each cylinder (Cylinder firing order)	1	5	3	6	2	4
Valve adjustment cylinder number	6	2	4	1	5	3



- Use a feeler gauge to adjust the valve clearance and tighten the mounting nuts to the specified torque.



Torque	4.4 kg·m
--------	----------

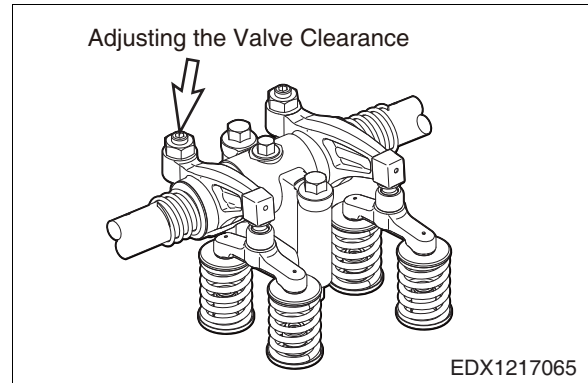

6.3.21. Rocker arm assembly



- Apply oil to the rocker arm bushing and shaft, use mounting bolts to align the parallel pins installed on the bracket with the top of the cylinder head, then tighten the bolts.



- When tightening bolts, tighten them to the specified torque in a zig-zag tightening pattern.

Torque	M10 (x8) : 6.2 kg·m M8 : 2.2 kg·m
--------	--------------------------------------

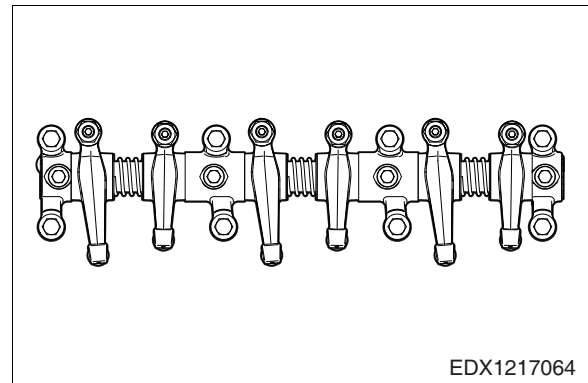

- Temporarily fit the valve clearance adjustment screw into the rocker arm.
- Install the spring, rocker arm, bracket, rocker arm, spring, washer and snap ring in the sequence described.



- Install the rocker arm and bracket in the same direction.

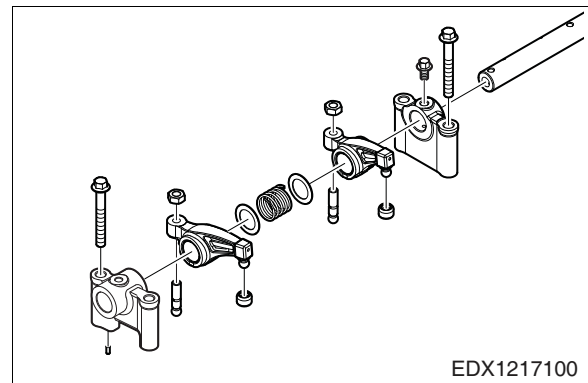

6.3.22. Oil cooler

- Insert the gasket, taking care to avoid oil leaks. Then, assemble the oil cooler with the oil cooler cover.
- Assemble the oil cooler cover assembly with the cylinder block, taking care not to damage the gasket.
- Assemble the connecting pipe between the coolant pump and oil cooler.

Torque	2.2 ±0.22 kg·m
--------	----------------

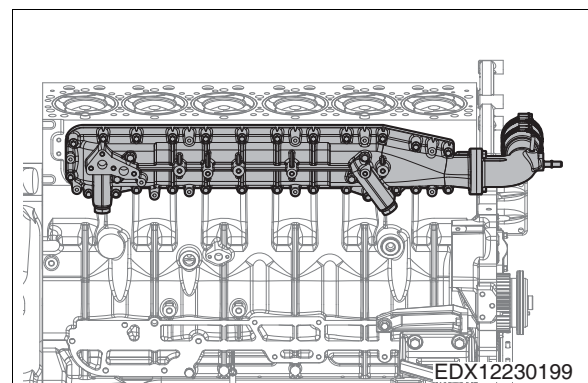

6.3.23. Oil filter

- Assemble the oil filter after inserting the gasket into the cylinder block.
- Install the oil packing and use a filter wrench to bring the surface of the O-ring on the oil filter cartridge into contact with the head seating surface. Then, tighten it an additional 3/4 to one turn.

Torque	3.1 kg·m
--------	----------

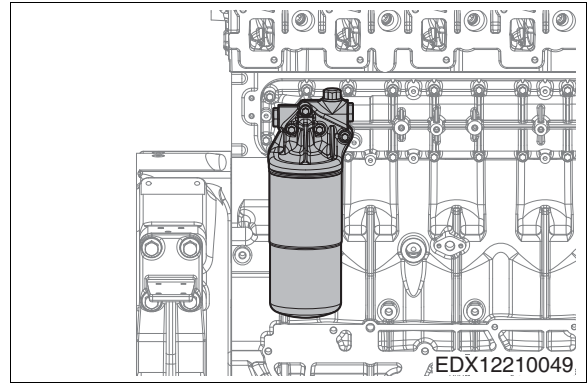

EDX12210049

6.3.24. Injection pump

- After greasing the O-ring on the high-pressure fuel pump, align the drive gear spline teeth with the timing gear case and insert it. (Assemble the spline teeth and high-pressure pump teeth regardless of the timing.)

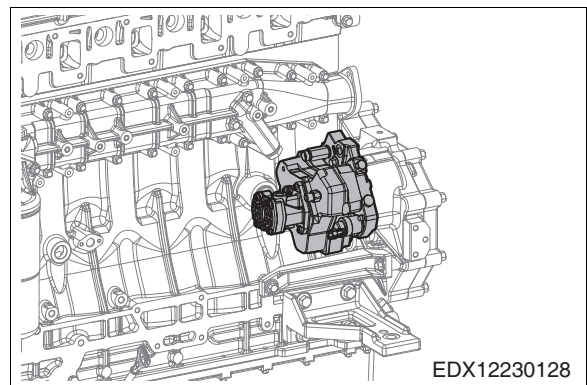

EDX12230128

- After inserting the high-pressure pump, assemble mounting bolts (A).
- Install fuel delivery inlet adapter (B) of the fuel pump.

Torque	Mounting bolt (A)	6.5 ±0.5 kg·m
	Adapter (B)	2.5 ±0.2 kg·m

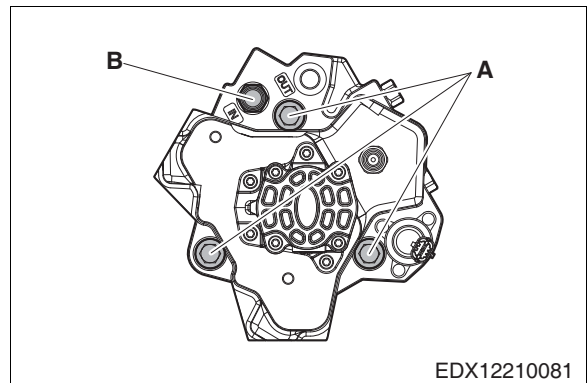

EDX12210081



Note:

Install one rubber coated washer on the adapter as well.

6.3.25. Vibration damper and crank pulley

- Assemble the vibration damper with the crankshaft pulley separately.



- After installing this assembly on the crankshaft, attach the thrust washers and tighten the bolts to the specified torque.

Part number	120121-00113A
Specifications	M14 × 1.5 × 110
Tightening Torque	22 ±2.2 kg·m

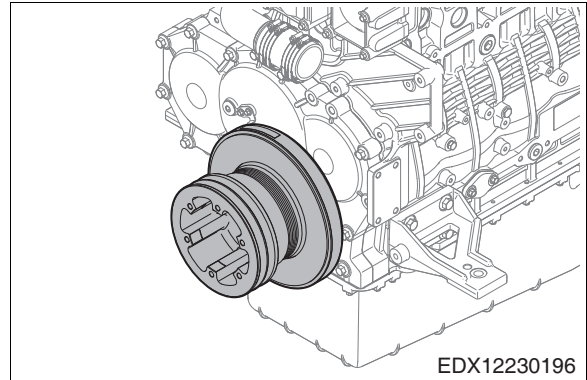

6.3.26. Fresh water pump

- Use the mounting bolts to assemble the fresh water pump with the TGC.
- Connect and assemble the coolant supply pipe with the bypass pipe and hose connected to the reservoir tank.

Torque	4.4 ±0.4 kg·m
--------	---------------

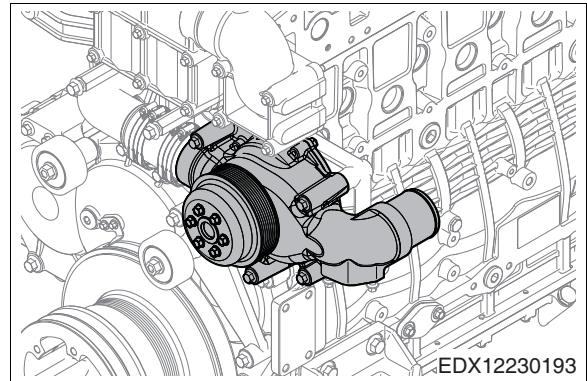

6.3.27. Saltwater pump

- Assemble the saltwater pump with the TGC, insert a new O-ring into the O-ring groove on the inlet/ outlet pipe flange, then assemble the pipe and hose.

Torque	6.2 ±1.55 kg·m
--------	----------------

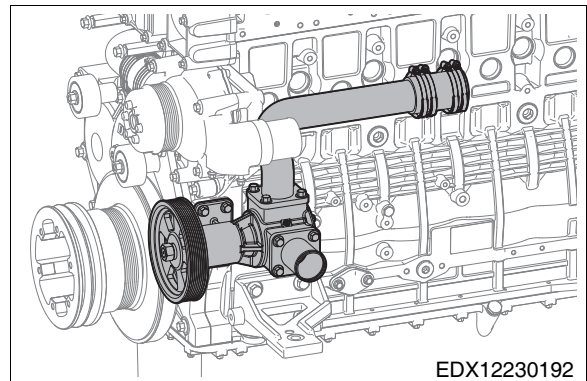

6.3.28. Exhaust manifold

- After temporarily assembling the heat exchanger and exhaust manifold, assemble the thermostat housing first in order to achieve the correct level of flatness of these parts. Then, adjust the flatness to the correct level and finally, tighten the mounting bolts on the heat exchanger.



- Assemble the exhaust manifold and heat exchanger assembly with the cylinder head. These parts are heavy so be especially careful when handling them. Assemble the exhaust manifold and coolant pipe. Then, assemble the hose connecting the heat exchanger to the saltwater pump.

Torque	6.6 ±0.66 kg·m
--------	----------------

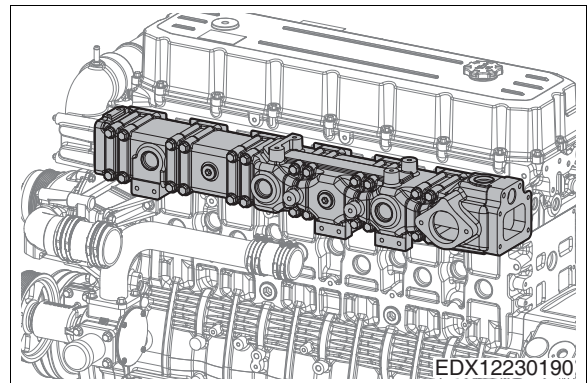

6.3.29. Heat exchanger

- Tighten the mounting bolts to install the heat exchanger.

Description	Torque
Mounting Bolt	6.2 ±1.55 kg·m

- Connect the coolant hose to the heat exchanger.

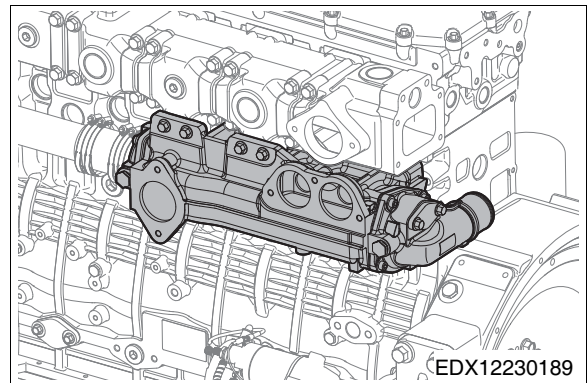

CAUTION

Assemble the heat exchanger tube so that the mark on top of the tube faces upwards. This is to secure a suitable baffle position for the heat exchanger tube, enabling smooth distribution of fresh water.

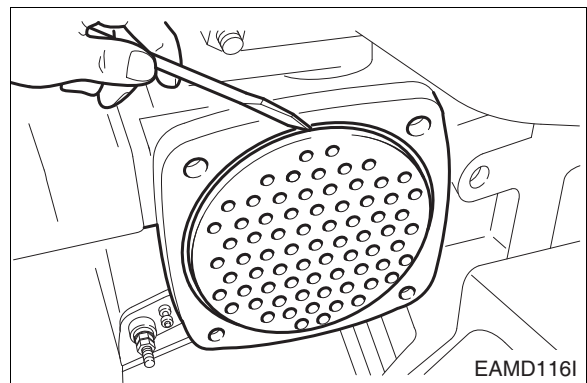

6.3.30. Thermostat

- Mount the thermostat in the thermostat housing along with a new gasket and O-ring.

Torque	4.4 ±0.4 kg·m
--------	---------------

- Assemble this assembly with the exhaust manifold and the body of the heat exchanger. Then, assemble them with the coolant bypass pipe.

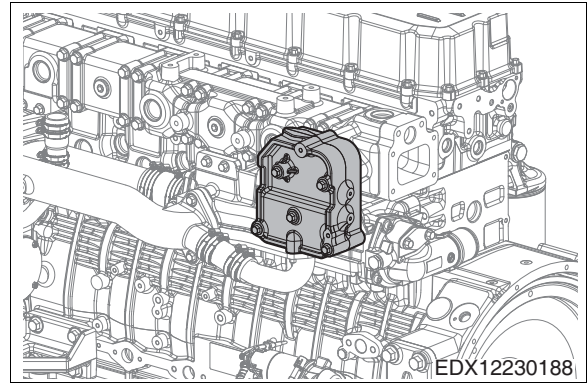

6.3.31. Intake manifold

- Attach the gasket and install the intake manifold.
- Install the fuel injection pump's negative pressure operated air hose on the intake manifold.

Torque	4.4 ±1.1 kg·m
--------	---------------



Note:

Ensure to install the steel gasket correctly with its projection facing the correct direction.

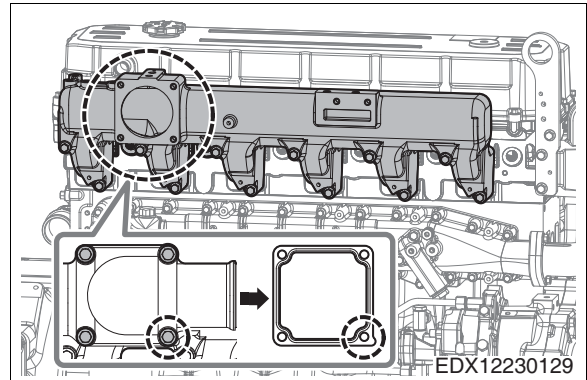

6.3.32. Engine stop solenoid

- After mounting the bracket, assemble the solenoid as shown in the picture and tighten the solenoid mounting bolts.
- Connect the stop lever and solenoid on the fuel injection pump with a cable and adjust the length of the cable.

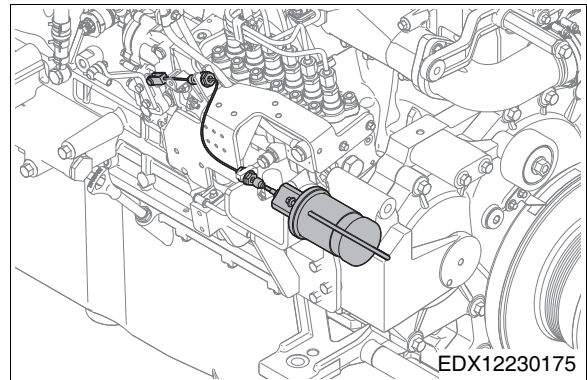

6.3.33. Common rail and high-pressure fuel pipes

- Install the common rail bracket and the common rail on the oil cooler.
- Install the high-pressure pipe between the common rail and the fuel pump.
- Install the high-pressure pipes between the high-pressure fuel connectors and the common rail.

Name	Torque
Common rail bracket, Common rail mounting bolts	2.2 kg-m
High-pressure fuel pipe Nut torque	4.0 ±0.4 kg-m

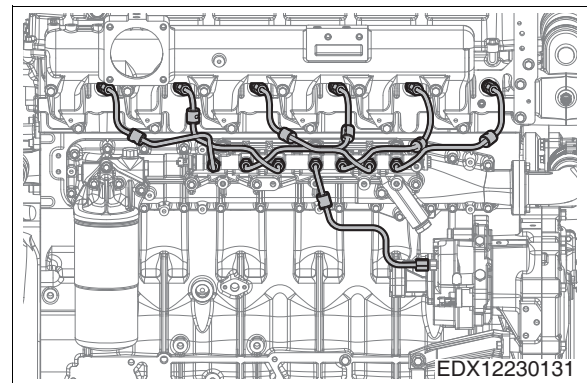
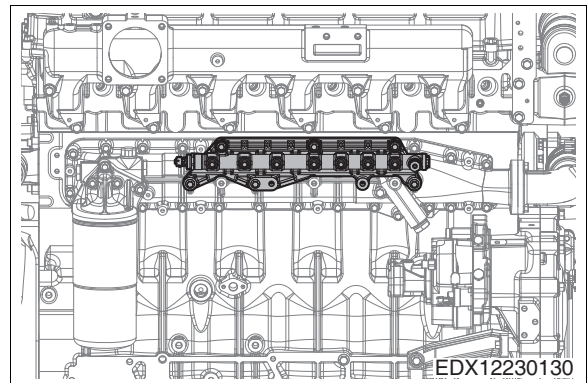

6.3.34. Fuel delivery pipe and fuel return pipe

Fuel delivery/return bracket

- Assemble the fuel delivery/return bracket using mounting bolts.
- Install the fuel delivery/return adapter and nuts.

Name	Torque
Nut tightening torque	7.5 kg-m

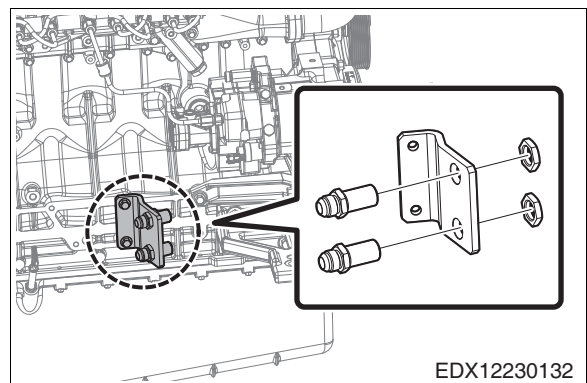

Fuel delivery pipe

- Install the fuel delivery pipe between the fuel pump and the fuel delivery/return bracket.
- Temporarily tighten the fuel pump using hollow screw (A), and temporarily tighten the bracket using union nut (B).



Note

When installing hollow screw (A), assemble one rubber coated washer on each side of the banjo union as well.

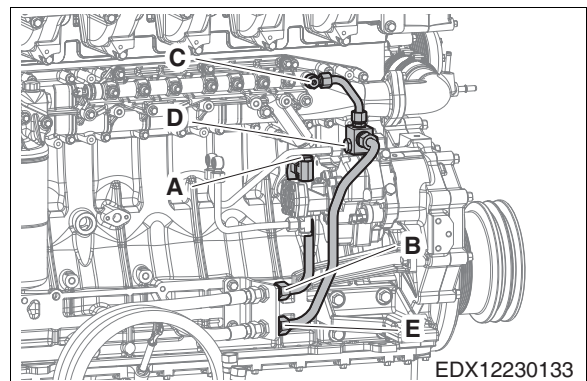

Fuel Return Pipe

- Install the fuel delivery pipe between the common rail, the fuel pump and the fuel delivery/return bracket.
- Temporarily tighten the common rail and fuel pump using hollow screws (C, D), and temporarily tighten the bracket using pipe union nut (B).



Note

When installing hollow screws (C, D), assemble one rubber coated washer on each side of the banjo union as well.

- Finish tightening the hollow screws on the common rail and fuel pump.

Name	Torque
Hollow screw tightening torque	2.5 kg·m

- Install pipe union nut (E) in the same way as the cutting rings.
- Install the injector fuel return pipe between the cylinder head and the common rail.
- Install it using hollow screws (F).

Name	Torque
Hollow screw tightening torque	0.8 kg·m



Note

When installing hollow screws (C, D), assemble one rubber coated washer on each side of the banjo union as well.

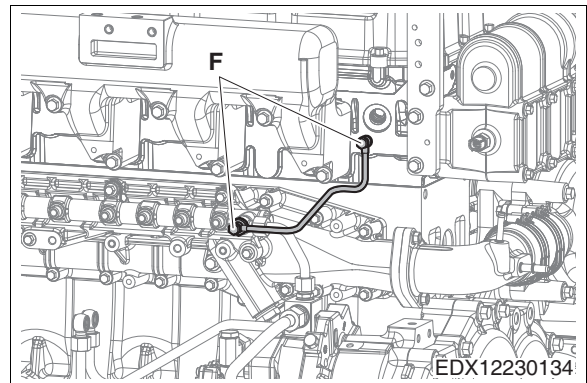

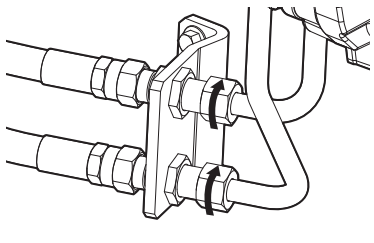
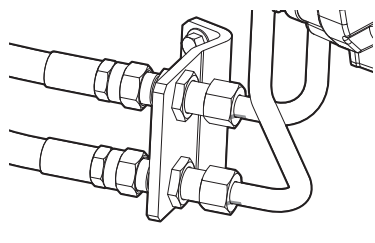
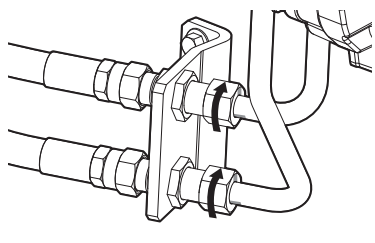
		
Turn the union nut by hand as far as it will go.	Align the union nut with the pipe in a straight line.	Turn the union nut 120°. (Two movements of the edges of the union nut)

6.3.35. Starter Motor

- Assemble the starter motor with the fly-wheel housing.

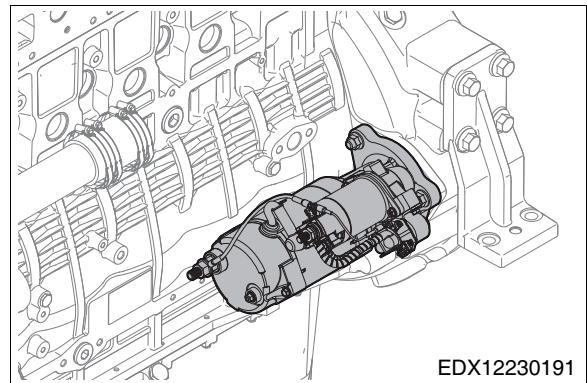

6.3.36. Turbocharger

- Install a new gasket on the exhaust manifold stud bolts, install a turbo-charger mounting spacer and insert a turbocharger gasket on top of it. Then, assemble the turbocharger with the mounting bolts.
- Assemble the oil supply pipe and return pipe with the top and bottom of the turbocharger.
- Install the gasket on the turbocharger exhaust outlet and assemble the exhaust elbow.

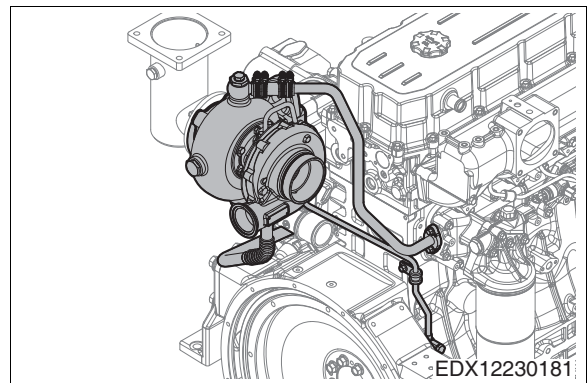

Description	Screws	Torque
Head socket bolt	M10 × 1.5	4.4 ±1.1 kg·m
Head socket bolt	M12 × 1.5	8 ±2 kg·m
Flange Nut	M10 × 1.25	6.6 ±0.6 kg·m
Oil Return Pipe		2.2 ±0.2 kg·m

6.3.37. Air filter

- Assemble the air filter with the turbo-charger air inlet. Then, install the filter element on top of it as shown in the picture.

Torque	0.8 ±0.08 kg·m
--------	----------------

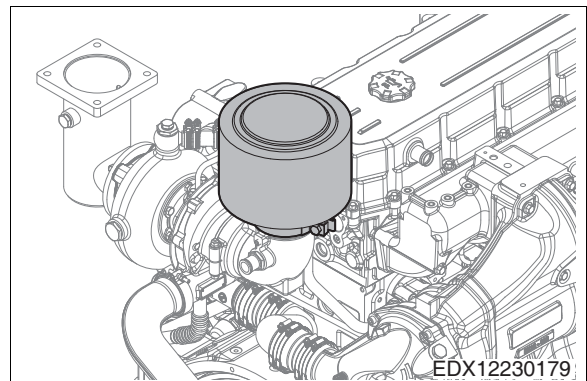

6.3.38. Intercooler

- Mount the intercooler bracket and assemble the intercooler.
- Connect the intake stake to the intake manifold.
- Assemble the pipe and hose connected to the intercooler and turbocharger inlet as shown in the picture.
- Install a support bracket so that the connecting pipe does not detach from the turbocharger inlet.

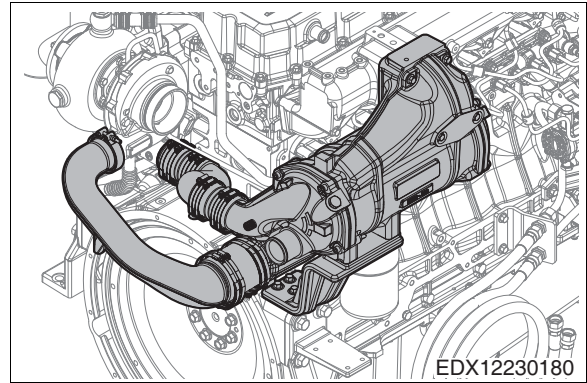

6.3.39. Reservoir tank

- Assemble the fresh water reservoir tank, assemble the rubber connecting hose and air bleeding hose with the bypass pipe, then tighten them with the clamps.

Description	Torque
Expansion tank mounting bolt	6.2 kg·m
Hose Clamp	0.2 +0.5 kg·m
Air bleeding clamp	0.13 ±0.1 kg·m

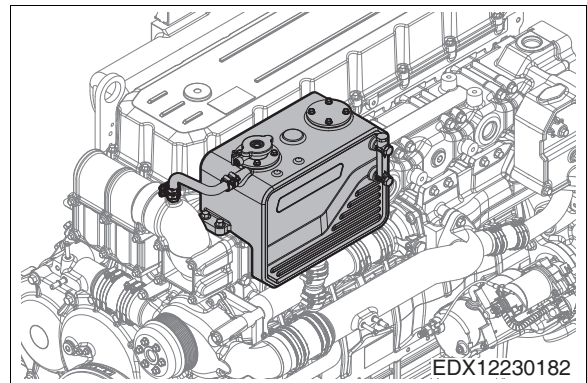

6.3.40. Fuel Filter

- Install the fuel filter bracket on the oil cooler using mounting bolts.
- Install the fuel filter on the fuel filter bracket using mounting bolts.
- Install fuel filter adapter (A) on the fuel filter.



Note

Install one rubber coated washer on the adapter as well.

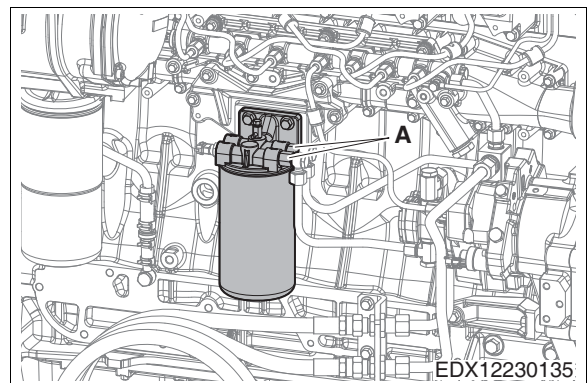

Assembling fuel filter pipes

- Install the fuel filter pipes between the fuel filter and the fuel pump.
- Temporarily tighten hollow screws (B, C) on the fuel filter and the fuel gear pump, and temporarily tighten pipe union nut (D) on the fuel pump.

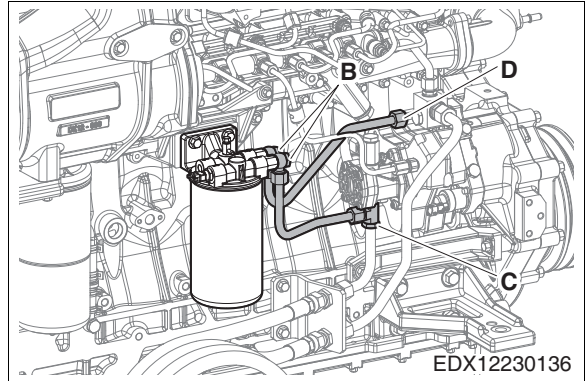

Note

When installing hollow screws (C, D), assemble one rubber coated washer on each side of the banjo union as well.

- Finish tightening the hollow screws on the fuel filter and fuel gear pump.

Name	Torque
Hollow screw tightening torque	2.5 kg·m

- Install pipe union nut (D) in the same way as the cutting rings.

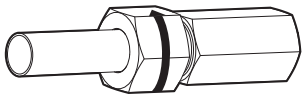
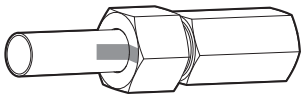
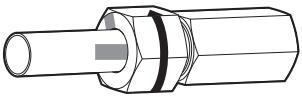
		
Turn the union nut by hand as far as it will go.	Align the union nut with the pipe in a straight line.	Turn the union nut 120°. (Two movements of the edges of the union nut)

Assembling low-pressure fuel pipes (cutting rings)

- Check to make sure that cutting rings and nuts are installed on the low-pressure fuel pipes.
- Check for foreign matter on the adapter mated with the pipe and wash the part if necessary.
- Apply engine oil to the threaded and conical sections of the adapter, the nut threads, and the outer circumference of the cutting ring (the red dotted part).

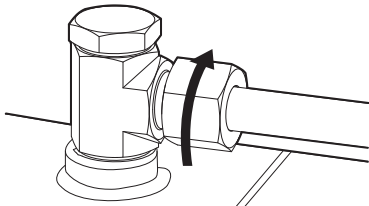
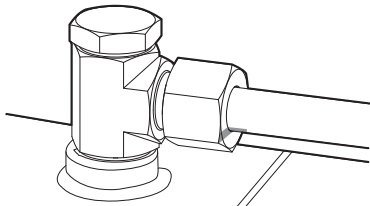
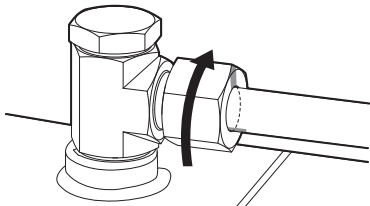
		
Insert the pipe into the adapter and tighten the union nut by hand as far as it will go.	Align the union nut with the pipe in a straight line.	Turn the union nut 120°. (Two movements of the edges of the union nut)

6.3.41. Cylinder head cover



- Assemble the cover packing with the cover and temporarily assemble the cover on top of the cylinder head. Then, tighten the mounting bolts to the specified tightening torque in the usual tightening order, starting from the inside and working outwards.

Torque	2.2 ±0.2 kg·m
--------	---------------

- Assemble the breather hose with the breather assembly.

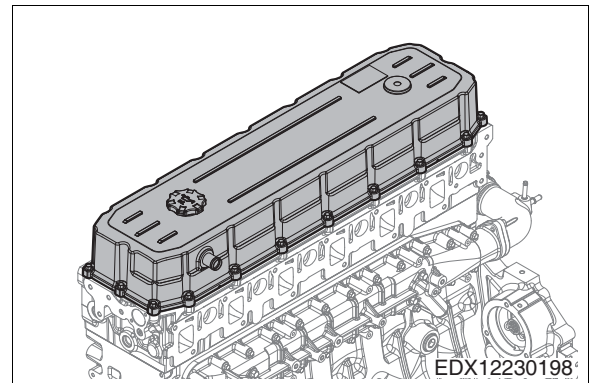

6.3.42. Alternator

- Assemble the alternator mounting bracket.
- Assemble the alternator and the alternator's protective cover with the bracket using mounting bolts.

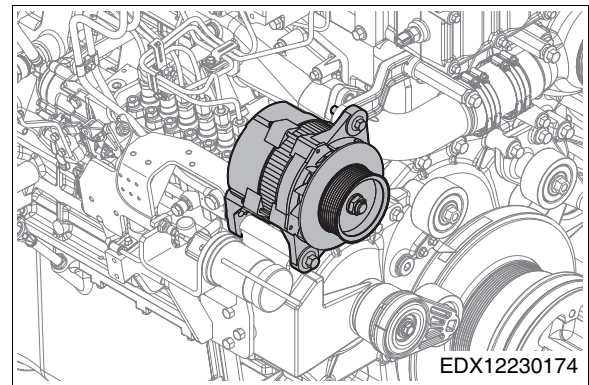

6.3.43. V-belt



- Use a tool in the square groove of the auto tensioner to rotate the tensioner clockwise. Then, install the Micro-V Belt on the crank pulley, generator pulley and fan drive pulley.

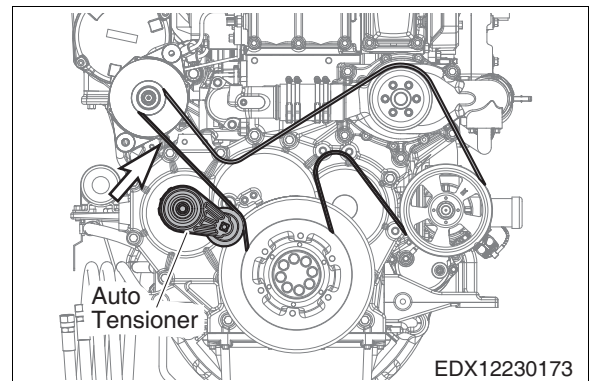

6.4. Test Operation After Maintenance

After performing maintenance and replacing (boring) the parts in the engine, the various lubricated drive components reassembled within the engine have not been broken in sufficiently. Hence, if the engine is initially operated at a high speed or under an excessive load, the oil film is easily destroyed, causing premature or uneven wear in lubricated drive components. This can lead to premature breakdown within the engine, making it difficult to guarantee longterm durability.

In order to prevent this danger, the operator must follow the instructions in the section "3.3 Operating the Engine."

7. Maintenance of Main Components

7.1. Lubrication System

Foreign matter in the engine oil pumped from the oil pan by the gear-type oil pump is filtered out by the oil filter. Then, the oil passes through the oil cooler to be cooled before arriving in the main oil passage in the cylinder block. Having arrived here, the oil is delivered to the various sliding parts of the engine, as well as the fuel injection pump, turbocharger and saltwater pump to lubricate the relevant parts. Next, it is returned to the oil pan to keep the engine functioning normally.

7.1.1. Specifications

Item	Specifications
Lubrication method	Forced circulation
Oil pump type	Gear driven
Oil pump relief valve Opening pressure	11 ±1.5 kg/cm ²
Valve opening pressure for oil spray nozzle	2.0 ±0.1 kg/cm ²
Oil filter type	Full flow

Item	Specifications
Filter	Cartridge type
Opening pressure of bypass valve (ships/generators/ excavators)	2.1 +0.3 kg/cm ²
Opening pressure of oil main gallery valve	4.0 +1.0 kg/cm ²

7.1.2. Oil filter

The oil filter is a cartridge-type filter. It must be replaced regularly along with the oil.

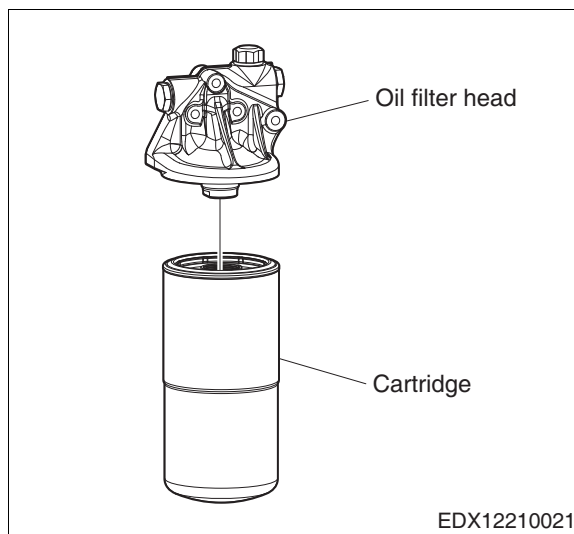

7.2. Cooling System

7.2.1. Coolant pump

- Loosen the bolts (5) and disconnect the pulley (4).
- After slightly heating the hub (3), use a puller jig to remove it.
- Loosen bolt (9) and remove housing cover (7).
- After slightly heating the impeller (6), use a puller jig to remove it.
- Remove the mechanical seal (10).
- Remove the snap ring (11) and the unit bearing (2).
- Reassemble in the reverse order.
- In order to reassemble the impeller (6), use a gauge to maintain a consistent clearance (5 ~ 9).

* The water pump assembly and disassembly processes involve a significant amount of press-fitting, making them difficult to do without the necessary tools and jigs.

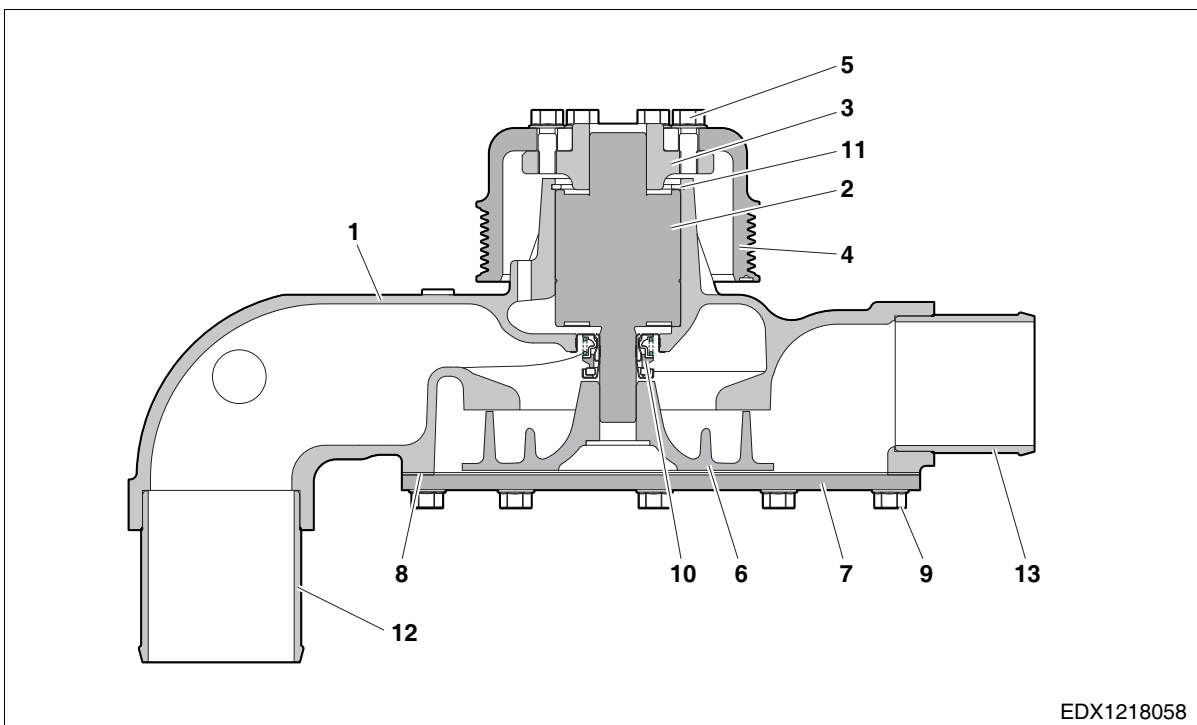

- | | | |
|-----------------------------|-------------------------|---------------------|
| 1. Fresh water pump housing | 5. Pulley mounting bolt | 10. Mechanical seal |
| 2. Unit bearing | 6. Impeller | 11. Snap ring |
| 3. Hub | 7. Housing cover | 12. Outlet pipe |
| 4. Pulley | 8. Gasket | 13. Inlet pipe |
| | 9. Cover mounting bolt | |

7.3. Fuel System

7.3.1. General fuel system information

This engine is equipped with a high-pressure common rail fuel injection system and consists of the components shown in the "fuel system schematic diagram" below. The system is designed to function optimally according to the engine performance.

After leaving the fuel tank and passing through the primary fuel filter (oil-water separator), fuel is filtered of all water and large particles of foreign matter; then, the fuel is sent to the secondary fuel filter by the low-pressure gear pump installed in the high-pressure fuel pump. Here, small particles of foreign matter which may cause problems in the injection system are removed. Then, after the fuel is pressurized to a suitably high pressure for the required engine performance, the fuel is sent to the common rail where it is injected into the combustion chamber at a high pressure by injectors controlled by the ECU. The fuel remaining after combustion is complete and the fuel used to lubricate and cool the high-pressure pump, common rail and injectors are gathered together and returned to the fuel tank.

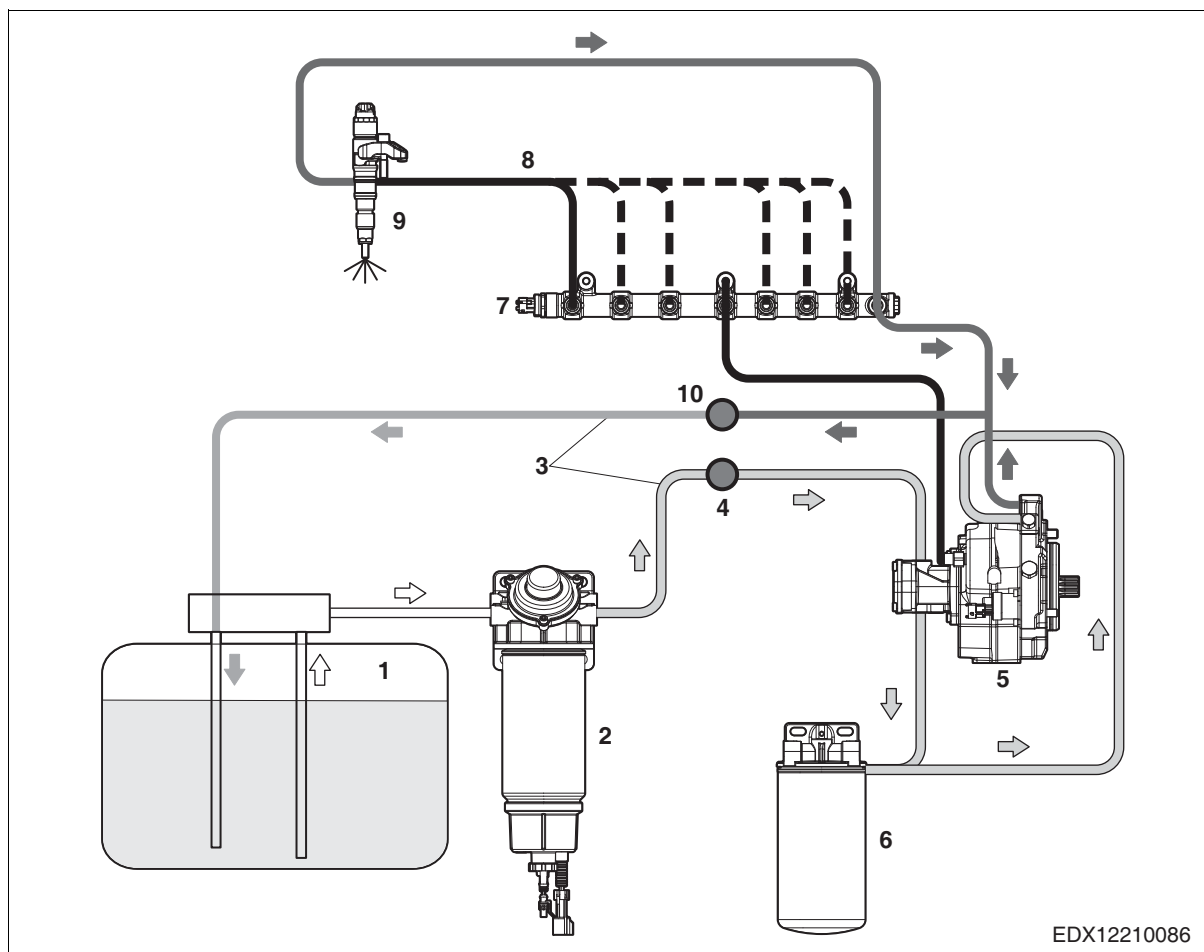

No.	Part Name
1.	Fuel tank
2.	Primary Fuel Filter
3.	Fuel hose SAE J516 37° FLARE COUPLING (7/8-14 UNF)
4.	Engine fuel inlet port (7/8-14 UNF SAE J516 37° MALE CONE)

No.	Part Name
5.	High-pressure fuel pump
6.	Secondary fuel filter
7.	Common rail
8.	High-pressure fuel pipe
9.	Injectors
10.	Engine fuel outlet port (7/8-14 UNF SAE J516 37° MALE CINE)

7.3.2. High-pressure fuel pump

The high-pressure fuel pump consists of the pump body, the low-pressure fuel pump, and the metering unit.

The high-pressure fuel pump pressurizes fuel from the low-pressure fuel pump and secondary fuel filter to the high pressures (DX12: 1,800 bar) required for engine operation and supplies this high-pressure fuel to the common rail and injectors. The metering unit controls the amount of fuel supplied to the common rail depending on the engine load conditions.

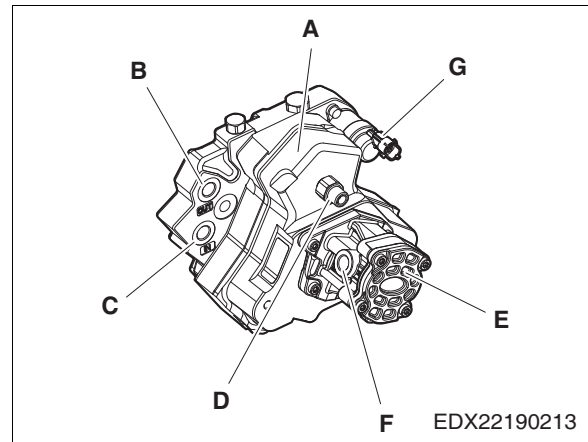

A	High-pressure fuel pump
B	High-pressure fuel pump return fuel outlet (To. Engine fuel outlet port)
C	High-pressure fuel pump inlet (From. Secondary fuel filter)
D	High-pressure fuel pump inlet (To. Common rail)
E	Low-pressure fuel pump
F	Low-pressure fuel pump inlet (From. Engine fuel inlet port)
G	Metering unit
H	Low-pressure fuel pump outlet (To. Secondary fuel filter)

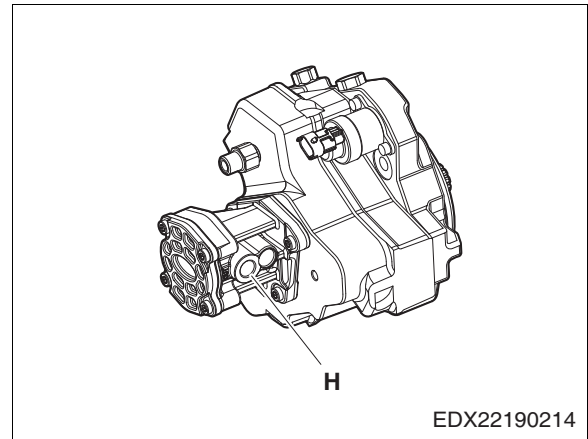

7.3.3. Common rail

The common rail consists of the common rail body, pressure sensor, and pressure limiter valve. The common rail maintains a constant fuel pressure (DX12: 1,800 bar) required by the injectors for fuel injection regardless of the engine load and operating mode.

A	Common rail
B	Bolts (M8 x 1.25 x 35 mm)

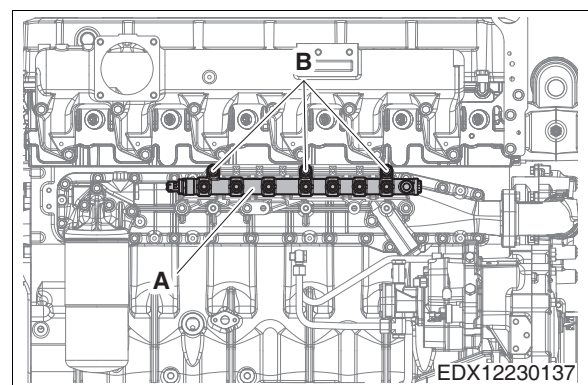

7.3.4. High-pressure fuel pipe

The high-pressure fuel pipes consist of pipes for transporting fuel, nuts for securing the pipes, and washers for distributing stress between the nuts and pipes. They serve to deliver high-pressure fuel compressed in the common rails to the injectors.

A	High-pressure fuel pipe
B	High-pressure fuel connector
C	High-pressure fuel connector nut
D	Injectors

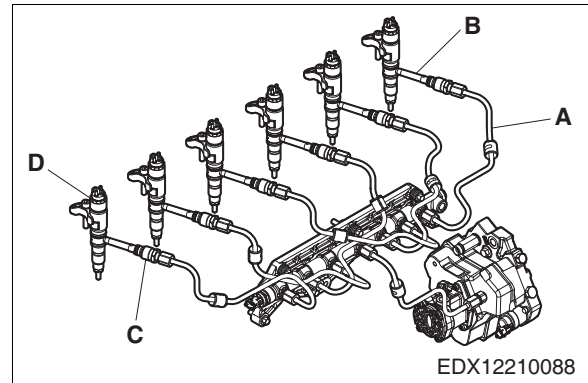

7.3.5. Injectors, High-Pressure Fuel Connectors

The injectors serve to inject fuel into the combustion chamber by controlling the solenoid valves based on signals from the ECU. The high-pressure fuel connectors consist of the connector body, edge filter, and O-ring for preventing leaks in the return fuel. The connectors are used to deliver fuel from the high-pressure fuel pipes to the injectors through connections between the high-pressure fuel pipes and injectors.

- Fuel lines connecting the common rail to the injectors require particular cleanliness as they lack a filtration function.
- Clean and remove all foreign matter from the holes drilled in the cylinder head for inserting high-pressure fuel connectors and holes for injectors.
- When the injector is disassembled, the high-pressure fuel connector must be replaced with a new one.
- In the event that fuel remaining in the fuel return line enters the combustion chamber while disassembling the injector, it must either be sucked out using a hand pump or discharged by cranking the starter motor with the fuel shut off.



CAUTION

When installing a new high-pressure fuel pipe after disconnecting the high-pressure fuel pipe connected to a high-pressure fuel connector (HPC), make sure to retighten the HPC mounting nuts to the specified torque. In addition, do not reuse high-pressure fuel pipes as the seal for high-pressure fuel is deformed while tightening them.

8. Electrical System

8.1. Circuit Diagram

8.1.1. General Information

- 1) This section provides information on the engine wire harnesses and the circuit number of connectors.

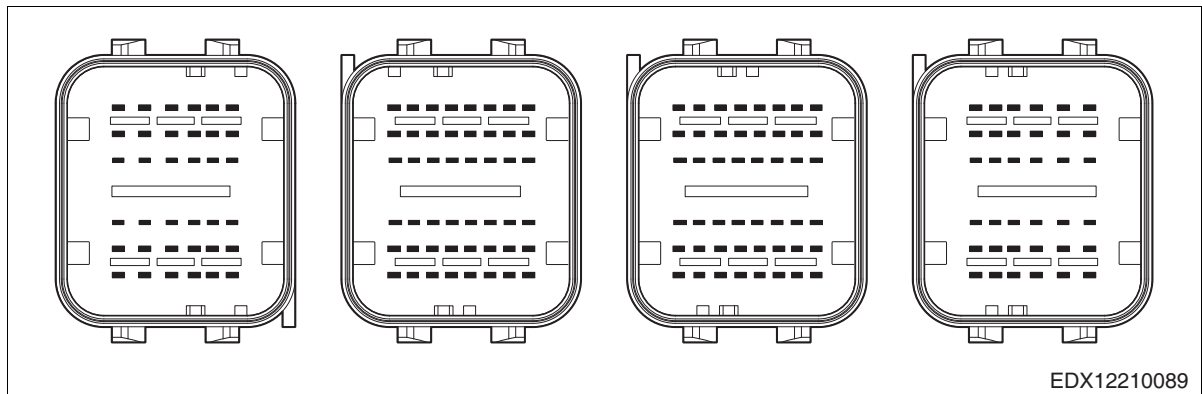

- 2) The wire colors are as follows.

- B : Black
- Brn : Brown
- G : Green
- Gra : Gray
- L : Blue
- O : Orange
- W : White
- Y : Yellow
- R : Red

- 3) The ECU pin no. refers to the pin number of each engine connector.
- 4) The sensor pin no. refers to the pin number of each sensor connector.

8.1.2. Engine Connectors

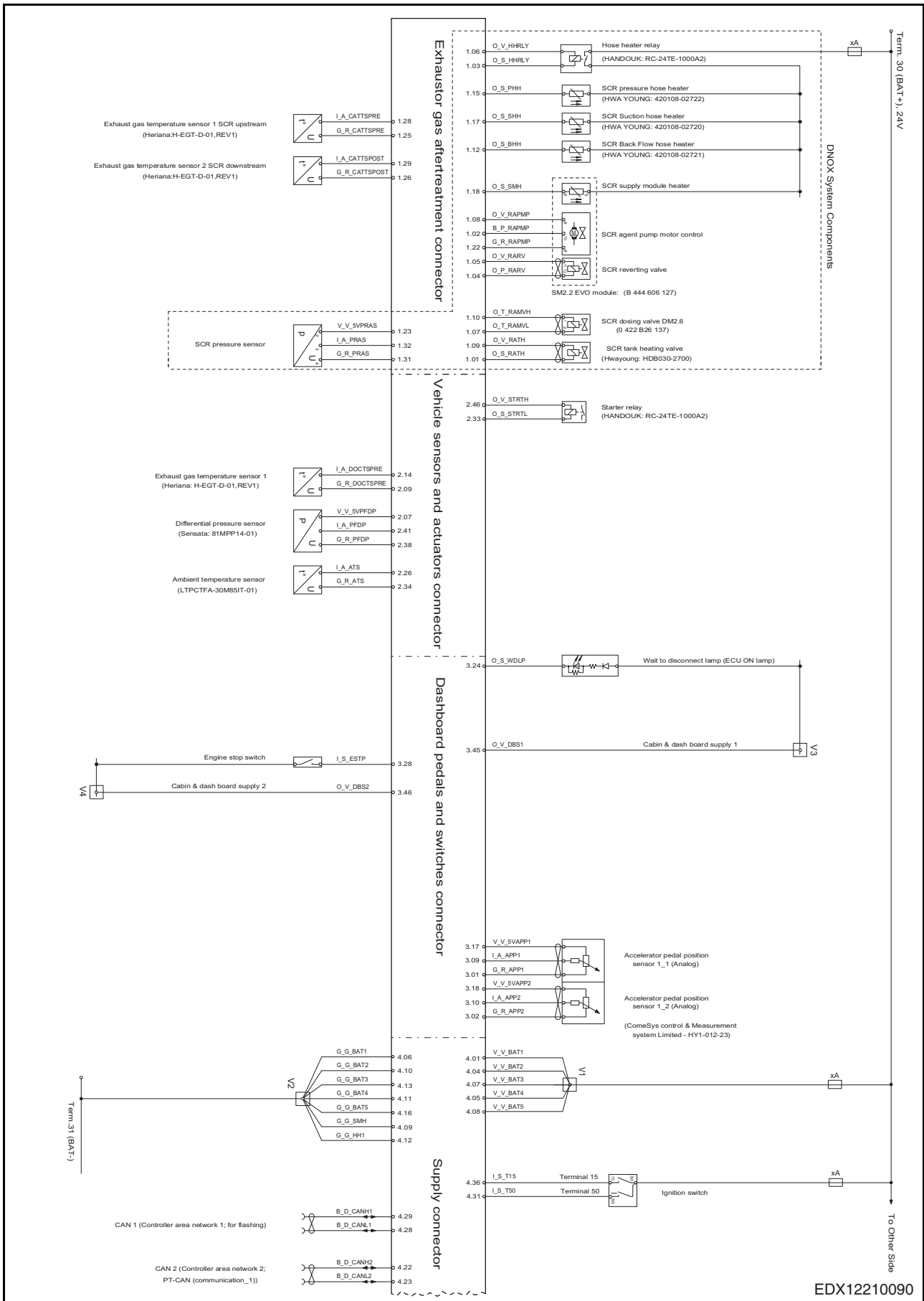

EDX12210090

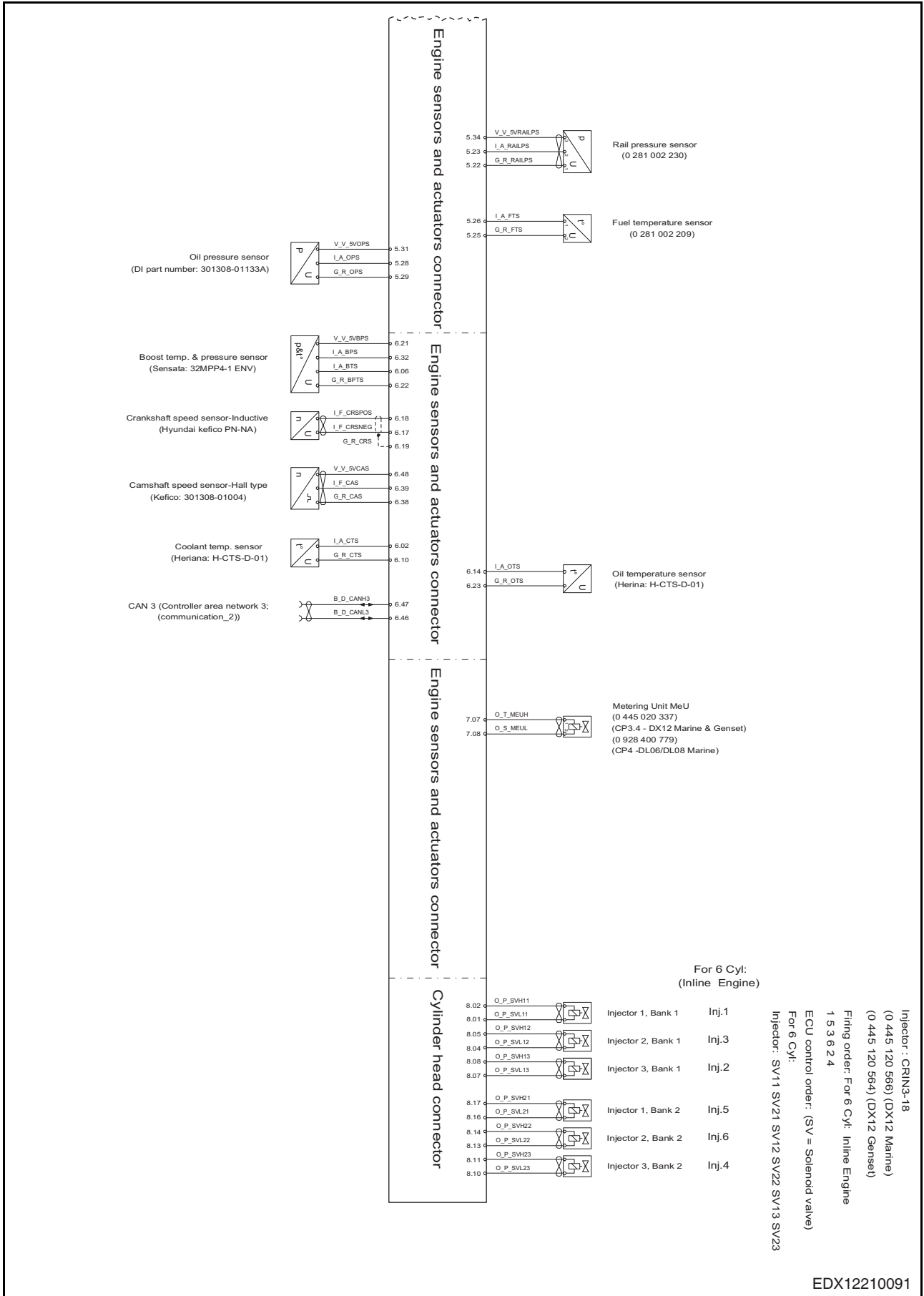

EDX12210091

8.1.3. Engine Control Unit (ECU) Engine Connectors

Engine Connector

No.	Wire Label	Size (mm ²)	Color	Circuit Description	From	No.	To	No.	Remark
1	8.16	1.50	B	Injector 1, Bank 2 Low	ECU 8	16	Injector CONN (INJ)	10	Twist Pair (8.16/8.17)
2	8.13	1.50	B	Injector 2, Bank 2 Low	ECU 8	13	Injector CONN (INJ)	12	Twist Pair (8.13/8.14)
3	8.10	1.50	B	Injector 3, Bank 2 Low	ECU 8	10	Injector CONN (INJ)	8	Twist Pair (8.10/8.11)
4	6.23	0.75	B	Oil Temp Sensor GND	ECU 6	23	Oil Temp Sensor (OTS)	1	
5	6.21	0.75	O	Boost Press/Temp Sensor PWR	ECU 6	21	Boost P/T Sensor (BPTS)	3	
6	5.34	0.75	O	Rail Press Sensor PWR	ECU 5	34	Rail Press Sensor (RPS)	3	Twist Pair (5.22/5.23/5.34)
7	5.26	0.75	R	Fuel Temp Sensor Signal	ECU 5	26	Fuel Temp Sensor (FTS)	1	
8	6.14	0.75	Brn	Oil Temp Sensor Signal	ECU 6	14	Oil Temp Sensor (OTS)	2	
9	4.22	0.75	R	CAN2 High	ECU 4	22	Inter CONN 1 (INT 1)	3	Twist Pair (4.22/4.23)
10	4.23	0.75	Brn	CAN2 Low	ECU 4	23	Inter CONN 1 (INT 1)	2	Twist Pair (4.22/4.23)
11	4.29	0.75	R	CAN1 High	ECU 4	29	OBD Connector (OBD)	2	Twist Pair (4.28/4.29)
12	4.28	0.75	Brn	CAN1 Low	ECU 4	28	OBD Connector (OBD)	1	Twist Pair (4.28/4.29)
13	1R	1.50	B	Fuel Heater Relay G	SP_03		Junction Box (JBOX) Fuel Heater Relay	85	Splice 03
14	19R	1.50	Br	Fuel Heater Relay S	SP_4.36		Junction Box (JBOX) Fuel Heater Relay	86	Splice 4.36
15	8.17	1.50	L	Injector 1, Bank 2 High	ECU 8	17	Injector CONN (INJ)	9	Twist Pair (8.16/8.17)
16	8.14	1.50	L	Injector 2, Bank 2 High	ECU 8	14	Injector CONN (INJ)	11	Twist Pair (8.13/8.14)
17	8.11	1.50	L	Injector 3, Bank 2 High	ECU 8	11	Injector CONN (INJ)	7	Twist Pair (8.10/8.11)
18									
19									
20	5.23	0.75	W	Rail Press Sensor Signal	ECU 5	23	Rail Press Sensor (RPS)	2	Twist Pair (5.22/5.23/5.34)
21	6.06	0.75	R	Boost Temp Sensor PWR	ECU 6	6	Boost P/T Sensor (BPTS)	2	
22	6.02	0.75	W	Coolant Temp Sensor Signal	ECU 6	2	Coolant Temp Sensor (CTS)	2	
23	8.02	1.50	L	Injector 1, Bank 1 High	ECU 8	2	Injector CONN (INJ)	1	Twist Pair (8.02/8.01)
24	8.05	1.50	L	Injector 2, Bank 1 High	ECU 8	5	Injector CONN (INJ)	5	Twist Pair (8.05/8.04)
25	8.08	1.50	L	Injector 3, Bank 1 High	ECU 8	8	Injector CONN (INJ)	3	Twist Pair (8.08/8.07)
26	7.07	0.75	R	Fuel Metering Unit	ECU 7	7	Fuel Metering Unit (FMU)	1	Twist Pair (7.07/7.08)
27	5.25	0.75	B	Fuel Temp Sensor GND	ECU 5	25	Fuel Temp Sensor (FTS)	2	

No.	Wire Label	Size (mm ²)	Color	Circuit Description	From	No.	To	No.	Remark
28	6.10	0.75	B	Coolant Temp Sensor GND	ECU 6	10	Coolant Temp Sensor (CTS)	1	
29	5.22	0.75	B	Rail Press Sensor GND	ECU 5	22	Rail Press Sensor (RPS)	1	Twist Pair (5.22/5.23/5.34)
30	12R	1.50	R	Starter Relay 1 30	SP_13R		Junction Box (JBOX) Starter Relay	30	Splice 13R
31	6.17	0.75	O	Crank Shaft Speed Sensor NEG	ECU 6	17	Crank Shaft Speed Sensor (CRS)	1	Shield 6.17/6.18
32	6.18	0.75	W	Crank Shaft Speed Sensor POS	ECU 6	18	Crank Shaft Speed Sensor (CRS)	2	Shield 6.17/6.18
33	6.48	0.75	O	Cam Shaft Speed Sensor Supply	ECU 6	48	Cam Shaft Speed Sensor (CAS)	3	Twist Pair (6.38/6.39/6.48)
34	6.39	0.75	W	Cam Shaft Speed Sensor Output	ECU 6	39	Cam Shaft Speed Sensor (CAS)	2	Twist Pair (6.38/6.39/6.48)
35	2.34	0.75	B	Ambient Temp Sensor Signal GND	ECU 2	34	Ambient Temp Sensor (ATS)	2	
36	6.19	0.75	B	Crank Shaft Sensor GND	ECU 6	19	Crank Shaft Speed Sensor (CRS)	3	Shield Drain (6.17/6.18)
37	6.38	0.75	B	Cam Shaft Sensor GND	ECU 6	38	Cam Shaft Speed Sensor (CAS)	1	Twist Pair (6.38/6.39/6.48)
38	8.01	1.50	B	Injector 1, Bank 1 Low	ECU 8	1	Injector CONN (INJ)	2	Twist Pair (8.02/8.01)
39	8.04	1.50	B	Injector 2, Bank 1 Low	ECU 8	4	Injector CONN (INJ)	6	Twist Pair (8.05/8.04)
40	8.07	1.50	B	Injector 3, Bank 1 Low	ECU 8	7	Injector CONN (INJ)	4	Twist Pair (8.08/8.07)
41	7.08	0.75	Brn	Fuel Metering Unit	ECU 7	8	Fuel Metering Unit (FMU)	2	Twist Pair (7.07/7.08)
42	2.26	0.75	Y	Ambient Temp Sensor Signal	ECU 2	26	Ambient Temp Sensor (ATS)	1	
43	6.32	0.75	W	Boost Press Sensor Signal	ECU 6	32	Boost P/T Sensor (BPTS)	4	
44	2C	0.75	B	Water In Fuel Sensor GND	Inter CONN 1 (INT 1)	5	Water In Fuel Sensor (WIF)	2	
45	6.22	0.75	B	Boost Press/Temp Sensor GND	ECU 6	22	Boost P/T Sensor (BPTS)	1	
46	3.17	0.75	R	Accelerator Pedal 1-1 V	ECU 3	17	Position Sensor (PSS)	F	Twist Pair (3.01/3.09/3.17)
47	4.01	0.75	R	ECU Power Supply	ECU 4	1	SP_02		Splice 02
48	1C	0.75	R	Water In Fuel Sensor (V)	Inter CONN 1 (INT 1)	4	Water In Fuel Sensor (WIF)	1	
49	20R	1.50	R	ECU Power Supply	SP_02		Junction Box (JBOX) Fuse 5 (25A)	2	Splice 02
50	4.06	0.75	B	ECU Ground	ECU 4	6	SP_03		Splice 03
51	4.09	0.75	B	ECU Ground	ECU 4	9	SP_03		Splice 03
52	3.28	0.75	R	E/G Emergency Stop Switch S	ECU 3	28	Inter CONN 1 (INT1)	14	
53	1.28	0.75	Y	SCR Upstream Signal	ECU 1	28	Inter CONN 2 (INT2)	21	
54	1.25	0.75	R	SCR Upstream GND	ECU 1	25	Inter CONN 2 (INT2)	22	
55	4.04	0.75	R	ECU Power Supply	ECU 4	4	SP_02		Splice 02
56	4.05	0.75	R	ECU Power Supply	ECU 4	5	SP_02		Splice 02

No.	Wire Label	Size (mm ²)	Color	Circuit Description	From	No.	To	No.	Remark
57	4.10	0.75	B	ECU Ground	ECU 4	10	SP_03		Splice 03
58	4.11	0.75	B	ECU Ground	ECU 4	11	SP_03		Splice 03
59	3.09	0.75	W	Accelerator Pedal 1-1 Signal	ECU 3	9	Position Sensor (PSS)	E	Twist Pair (3.01/3.09/3.17)
60	4.07	0.75	R	ECU Power Supply	ECU 4	7	SP_02		Splice 02
61	4.12	0.75	B	ECU Ground	ECU 4	12	SP_03		Splice 03
62	3.01	0.75	B	Accelerator Pedal 1-1 GND	ECU 3	1	Position Sensor (PSS)	D	Twist Pair (3.01/3.09/3.17)
63	4.31	0.75	W	Key Switch "START" (T50)	ECU 4	31	Inter CONN 1 (INT1)	29	
64	3.18	0.75	R	Accelerator Pedal 1-2 V	ECU 3	18	Position Sensor (PSS)	C	Twist Pair (3.02/3.10/3.18)
65	4.36	0.75	Br	Key-ON (T15)	ECU 4	36	Inter CONN 1 (INT1)	20	
66	4.08	0.75	R	ECU Power Supply	ECU 4	8	SP_02		Splice 02
67	3.46	0.75	R	E/G Emergency Stop Switch Supply	ECU 3	46	Inter CONN 1 (INT1)	22	
68	4.13	0.75	B	ECU Ground	ECU 4	13	SP_03		Splice 03
69	4.16	0.75	B	ECU Ground	ECU 4	16	SP_03		Splice 03
70	3.10	0.75	Y	Accelerator Pedal 1-2 Signal	ECU 3	10	Position Sensor (PSS)	B	Twist Pair (3.02/3.10/3.18)
71	3.02	0.75	B	Accelerator Pedal 1-2 GND	ECU 3	2	Position Sensor (PSS)	A	Twist Pair (3.02/3.10/3.18)
72	15R	2.00	R	SCR Relay 30	SP_04		Junction Box (JBOX) SCR Relay	30	Splice 04
73	2M	8.00	B	Starter Ground	Starter G (STS G)	1	SP_03		Splice 03
74	3M	1.50	B	Gauge Panel Ground	SP_03		Inter CONN 1 (INT1)	13	Splice 03
75	10R	1.50	R	Gauge Panel B	SP_13R		Inter CONN 1 (INT1)	17	Splice 13R
76	1B	1.50	R	Charge Signal	Alternator I (L)	1	Inter CONN 1 (INT1)	19	
77	14R	1.50	Y	Starter Signal	Starter S	1	Junction Box (JBOX) Starter Relay	87	
78	7D	0.75	O	Gearbox Oil Press Sensor Power	Gearbox O/P Sensor	1	Inter CONN 1 (INT1)	30	Shield 7D/15A
79	15A	0.75	W	Gearbox Oil Press Sensor Signal	Gearbox O/P Sensor	2	Inter CONN 1 (INT1)	31	Shield 7D/15A
80	2R	8.00	R	Battery	Alt B (ALTB)	1	SP_01		Splice 01
81	1.10	1.50	L	Dosing Valve High Side	ECU 1	10	Inter CONN 2 (INT2)	1	
82	1.07	1.50	B	Dosing Valve Low Side	ECU 1	7	Inter CONN 2 (INT2)	2	
83	1.18	1.50	W	SCR Supply Module Heater	ECU 1	18	Inter CONN 2 (INT2)	3	
84	1.08	1.50	R	SCR Agent Pump Motor Control (24V)	ECU 1	8	Inter CONN 2 (INT2)	4	
85	1.02	1.50	O	SCR Agent Pump Motor Control (B_P)	ECU 1	2	Inter CONN 2 (INT2)	5	
86	1.22	0.75	B	SCR Agent Pump Motor Control (GND)	ECU 1	22	Inter CONN 2 (INT2)	6	
87	1.05	1.50	R	SCR Reverting Valve (24V)	ECU 1	5	Inter CONN 2 (INT2)	7	
88	1.04	1.50	L	SCR Reverting Valve (P)	ECU 1	4	Inter CONN 2 (INT2)	8	

No.	Wire Label	Size (mm ²)	Color	Circuit Description	From	No.	To	No.	Remark
89	1.23	0.75	R	SCR Pressure Sensor (5V)	ECU 1	23	Inter CONN 2 (INT2)	9	
90	1.32	0.75	W	SCR Pressure Sensor (I)	ECU 1	32	Inter CONN 2 (INT2)	10	
91	1.31	0.75	B	SCR Pressure Sensor (G)	ECU 1	31	Inter CONN 2 (INT2)	11	
92	1.15	1.50	Brn	SCR Pressure Hose Heater	ECU 1	15	Inter CONN 2 (INT2)	12	
93	1.17	1.50	G	SCR Suction Hose Heater	ECU 1	17	Inter CONN 2 (INT2)	13	
94	1.12	1.50	W	SCR Back Flow Hose Heater	ECU 1	12	Inter CONN 2 (INT2)	14	
95	1.09	1.50	R	SCR Tank Heating Valve (24V)	ECU 1	9	Inter CONN 2 (INT2)	15	
96	1.01	1.50	Y	SCR Tank Heating Valve (S)	ECU 1	1	Inter CONN 2 (INT2)	16	
97	1.29	0.75	R	SCR Downstream Signal	ECU 1	29	Inter CONN 2 (INT2)	17	
98	1.26	0.75	B	SCR Downstream GND	ECU 1	26	Inter CONN 2 (INT2)	18	
99	16R	2.50	R	SCR Sensor Ubatt	SP_33		Junction Box (JBOX) SCR Relay	87	Splice 33
100	11A	1.50	B	SCR Sensor GND	SP_03		Inter CONN 2 (INT2)	20	Splice 03
101	6.46	0.75	Brn	CAN3 Low	ECU 6	46	Inter CONN 2 (INT2)	28	Twist Pair (6.46/6.47)
102	6.47	0.75	R	CAN3 High	ECU 6	47	Inter CONN 2 (INT2)	29	Twist Pair (6.46/6.47)
103	2.14	0.75	Y	Exhaust Gas Temperature Sensor (I)	ECU 2	14	EGT1 Sensor (EGT1)	2	
104	2.09	0.75	B	Exhaust Gas Temperature Sensor (G)	ECU 2	9	EGT1 Sensor (EGT1)	1	
105	2.07	0.75	R	DPF DP Sensor 5V Sensor Supply 1B	ECU 2	7	Inter CONN 2 (INT2)	23	
106	2.41	0.75	Brn	DPF DP Sensor Flex I/O 18	ECU 2	41	Inter CONN 2 (INT2)	24	
107	2.38	0.75	B	DPF DP Sensor GDN	ECU 2	38	Inter CONN 2 (INT2)	25	
108	1.06	1.50	R	SCR Relay S	ECU 1	6	Junction Box (JBOX) SCR Relay	86	
109	1.03	1.50	Y	SCR Relay G	ECU 1	3	Junction Box (JBOX) SCR Relay	85	
110	2.46	0.75	R	Starter Relay S	ECU 2	46	Junction Box (JBOX) Starter Relay	86	
111	2.33	0.75	Y	Starter Relay G	ECU 2	33	Junction Box (JBOX) Starter Relay	85	
112	17R	5.00	R	Fuel Heater Relay	SP_01		Junction Box (JBOX) Fuel Heater Relay	30	Splice 01
113	3R	5.00	R	Battery	SP_01		SP_04		Splice 01, Splice 04
114	18R	5.00	R	Fuel Heater Relay	SP_06		Junction Box (JBOX) Fuel Heater Relay	87	Splice 06
115	3.24	0.75	B	Wait To Disconnect LED Lamp GND	ECU 3	24	Inter CONN 1 (INT1)	7	
116	3.45	0.75	R	Wait To Disconnect LED Lamp Supply	ECU 3	45	Inter CONN 1 (INT1)	8	
117	9R	1.50	R	Urea Tank/NOX Sensor Supply	Inter CONN 2 (INT2)	26	Junction Box (JBOX) Fuse 1 (15A)	2	
118	8R	1.50	R	Fuel Heater V	Fuel Heater (BOWL)	A	Junction Box (JBOX) Fuse 2 (15A)	2	
119	5M	1.50	B	Fuel Heater GND	Fuel Heater (BOWL)	B	SP_03		Splice 03
120	21R	1.50	R	Urea Tank/NOX Sensor Supply Fuse	SP_16R		Junction Box (JBOX) Fuse 1 (15A)	1	Splice 16R

No.	Wire Label	Size (mm ²)	Color	Circuit Description	From	No.	To	No.	Remark
121	22R	1.50	R	Fuel Heater V Fuse	SP_06		Junction Box (JBOX) Fuse 2 (25A)	1	Splice 06
122	13R	1.50	R	Battery	Inter CONN 1 (INT1)	27	Junction Box (JBOX) Fuse 4 (5A)	2	
123	4R	1.50	R	Auxiliary Relay B Fuse	Inter CONN 2 (INT2)	19	Junction Box (JBOX) Fuse 3 (25A)	1	
124	5R	1.50	R	Battery Fuse	SP_04		Junction Box (JBOX) Fuse 4 (5A)	1	Splice 04
125	6R	1.50	R	ECU Power Supply Fuse	SP_04		Junction Box (JBOX) Fuse 5 (25A)	1	Splice 04
132	32R	1.50	R	Fuel Heater V Fuse	SP_06		Junction Box (JBOX) Fuse 6 (25A)	1	Splice 06
133	31R	1.50	R	Fuel Heater V	Fuel Heater (Stick)	A	Junction Box (JBOX) Fuse 6 (25A)	2	
144	4G	1.50	B	Fuel Heater GND	Fuel Heater (Stick)	B	SP_03		Splice 03
145	4.23A	0.75	Brn	CAN2 Low	OBD Connector (OBD)	5	SP_4.23		Splice 4.23, Twist Pair (4.22A/4.23A)
146	4.23A	0.75	R	CAN2 High	OBD Connector (OBD)	6	SP_4.22		Splice 4.22, Twist Pair (4.22A/4.23A)
147	1G	1.50	B	OBD GND	OBD Connector (OBD)	3	SP_03		Splice 03
148	2G	1.50	B	GND	Inter CONN 1 (INT 1)	6	SP_03		Splice 03
149	30R	1.50	R	OBD V	OBD Connector (OBD)	4	SP_13R		Splice 13R
150	5.28	0.75	W	Oil Press Sensor Signal	ECU 5	28	Oil Press Sensor (OPS)	1	Twist Pair (5.28/5.29/5.31)
151	5.29	0.75	B	Oil Press Sensor GND	ECU 5	29	Oil Press Sensor (OPS)	2	Twist Pair (5.28/5.29/5.31)
152	5.31	0.75	O	Oil Press Sensor Supply	ECU 5	31	Oil Press Sensor (OPS)	3	Twist Pair (5.28/5.29/5.31)
153	33R	1.50	R	SCR Sensor Ubatt	Junction Box (JBOX) Fuse 3 (25A)	2	SP_33		Splice 33
154	1.30	0.75	Y	Exhaust Gas Temperature Sensor (I)	ECU 1	30	EGT 2 Sensor (EGT 2)		
155	1.27	0.75	B	Exhaust Gas Temperature Sensor (I)	ECU 1	27	EGT 2 Sensor (EGT 2)		
156	4.36A	0.75	Brn	OBD Key-on (T15)	OBD Connector (OBD)	6	SP_4.36		Splice 4.36

Aftertreatment System Connectors

No.	Wire Label	Size (mm ²)	Color	Circuit Description	From	No.	To	No.	Remark
1	1.23	0.75	R	SCR Pressure Sensor (5V)	Inter Connector2 for Engine (INT2)	9	Urea Supply Module (SPP)	2	
2	1.32	0.75	W	SCR Pressure Sensor (I)	Inter Connector2 for Engine (INT2)	10	Urea Supply Module (SPP)	3	
3	1.31	0.75	B	SCR Pressure Sensor (G)	Inter Connector2 for Engine (INT2)	11	Urea Supply Module (SPP)	4	Splice_1
4	16RA	1.50	R	SCR Supply Module Heater BAT+	SP_1		Urea Supply Module (SPP)	5	
5	1.18	1.50	W	SCR Supply Module Heater Output Low-side	Inter Connector2 for Engine (INT2)	3	Urea Supply Module (SPP)	6	
6	1.22	0.75	B	SCR Agent Pump Motor Control (Ground)	Inter Connector2 for Engine (INT2)	6	Urea Supply Module (SPP)	8	
7	1.08	1.50	R	SCR Agent Pump Motor Control (24V)	Inter Connector2 for Engine (INT2)	4	Urea Supply Module (SPP)	9	
8	1.02	1.50	Or	SCR Agent Pump Motor Control (B_P)	Inter Connector2 for Engine (INT2)	5	Urea Supply Module (SPP)	10	
9	1.05	1.50	R	SCR Preheating Valve (24V)	Inter Connector2 for Engine (INT2)	7	Urea Supply Module (SPP)	11	
10	1.04	1.50	L	SCR Preheating Valve (P)	Inter Connector2 for Engine (INT2)	8	Urea Supply Module (SPP)	12	
11	1.15	1.50	Brn	Outlet Line Heater Output Low-side	Inter Connector2 for Engine (INT2)	12	Outlet Line Heater (OUTH)	1	
12	16RB	1.50	R	Outlet Line Heater BAT	SP_1		Outlet Line Heater (OUTH)	2	Splice_1
13	1.17	1.50	G	Inlet Line Heater Output Low-side	Inter Connector2 for Engine (INT2)	13	Inlet Line Heater (OUTH)	1	
14	16RC	1.50	R	Inlet Line Heater BAT	SP_1		Inlet Line Heater (OUTH)	2	Splice_1
15	1.12	1.50	W	Back Flow Line Heater Output Low-side	Inter Connector2 for Engine (INT2)	14	Back Flow Line Heater (BFH)	1	
16	16RD	1.50	R	Back Flow Line Heater BAT	SP_1		Back Flow Line Heater (BFH)	2	Splice_1
17	16R	1.50	R	BAT+	Inter Connector2 for Engine (INT2)	19	SP_1		Splice_1
18	1.09	1.50	R	SCR Tank Heating Valve (24V)	Inter Connector2 for Engine (INT2)	15	Tank Heating Valve (THV)	1	
19	1.01	1.50	Y	SCR Tank Heating Valve (S)	Inter Connector2 for Engine (INT2)	16	Tank Heating Valve (THV)	2	
20	9R	1.50	R	Urea/NOX Sensor Supply	Inter Connector2 for Engine (INT2)	26	SP_2		Splice_2
21	11A	1.50	B	Urea/NOX Sensor Ground	Inter Connector2 for Engine (INT2)	20	SP_3		Splice_3
22	9RA	1.50	R	NOX Sensor Supply	SP_2		NOX Sensor (NOX)	1	Splice_2
23	6.46A	0.75	Brn	NOX Sensor CAN3 Low	SP_4		NOX Sensor (NOX)	2	Splice_4, Twist Pair (6.46A/ 6.47A)
24	6.47A	0.75	R	NOX Sensor CAN3 High	SP_5		NOX Sensor (NOX)	3	Splice_5, Twist Pair (6.46A/ 6.47A)
25	11B	1.50	B	NOX Sensor Ground	SP_3		NOX Sensor (NOX)	4	Splice_3
26	9RB	1.50	R	Urea Tank Supply	SP_2		Urea Tank (UREA)	1	Splice_2

No.	Wire Label	Size (mm ²)	Color	Circuit Description	From	No.	To	No.	Remark
27	6.46B	0.75	Brn	Urea Tank CAN3 Low	SP_4		Urea Tank (UREA)	4	Splice_4, Twist Pair (6.46B/6.47B)
28	6.47B	0.75	R	Urea Tank CAN3 High	SP_5		Urea Tank (UREA)	3	Splice_5, Twist Pair (6.46B/6.47B)
29	11C	1.50	B	Urea Tank Ground	SP_3		Urea Tank (UREA)	2	Splice_3
30	6.46C	0.75	Brn	CAN3 Low Resistor	SP_4		Resistance (R120)	2	Splice_4, Twist Pair (6.46C/6.47C)
31	6.47C	0.75	R	CAN3 High Resistor	SP_5		Resistance (R120)	1	Splice_5, Twist Pair (6.46C/6.47C)
32	6.46	0.75	Brn	CAN3 Low	Inter Connector2 for Engine (INT2)	28	SP_4		Splice_4, Twist Pair (6.46/6.47)
33	6.47	0.75	R	CAN3 High	Inter Connector2 for Engine (INT2)	29	SP_5		Splice_5, Twist Pair (6.46/6.47)
34	1.10	1.50	L	SCR Dosing Valve Output High-side	Inter Connector2 for Engine (INT2)	1	Dosing Module (DM)	1	Twist Pair (1.10/1.07)
35	1.07	1.50	B	SCR Dosing Valve Output Low-side	Inter Connector2 for Engine (INT2)	2	Dosing Module (DM)	2	Twist Pair (1.10/1.07)
36	2.07	0.75	R	DPF Sensor Supply	Inter Connector2 for Engine (INT2)	23	SCR DP Sensor (DPS)	1	
37	2.38	0.75	B	DPF Sensor Ground	Inter Connector2 for Engine (INT2)	25	SCR DP Sensor (DPS)	2	
38	2.41	0.75	Brn	DPF Sensor I/O	Inter Connector2 for Engine (INT2)	24	SCR DP Sensor (DPS)	3	
39	1.25	0.75	B	SCR Upstream Ground	Inter Connector2 for Engine (INT2)	22	SCR Up Temp Sensor (SCR1)	1	
40	1.28	0.75	B	SCR Upstream Signal	Inter Connector2 for Engine (INT2)	21	SCR Up Temp Sensor (SCR1)	2	
41	1.26	0.75	B	SCR Downstream Ground	Inter Connector2 for Engine (INT2)	18	SCR Down Temp Sensor (SCR2)	1	
42	1.29	0.75	R	SCR Downstream Signal	Inter Connector2 for Engine (INT2)	17	SCR Down Temp Sensor (SCR2)	2	

Extension Wires

No.	Wire Label	Size (mm ²)	Color	Circuit Description	From	No.	To	No.	Remark
1	3.24	0.75	B	Wait to disconnect LED Lamp GND	Inter Connector1 for Engine (INT1)	7	Gauge Panel (GPA)	6	
2	3.45	0.75	R	Wait to disconnect LED Lamp Supply	Inter Connector1 for Engine (INT1)	8	Gauge Panel (GPA)	5	
3	1C	0.75	Y	Water In Fuel Sensor Signal	Inter Connector1 for Engine (INT1)	4	Gauge Panel (GPA)	19	
4	2C	0.75	B	Water In Fuel Sensor GND	Inter Connector1 for Engine (INT1)	5	Gauge Panel (GPA)	20	
5	15A	1.00	B	Gearbox Oil Press Sensor GND	Inter Connector1 for Engine (INT1)	31	Gauge Panel (GPA)	17	
6	3.46	0.75	R	E/G Emergency Stop Switch Supply	Inter Connector1 for Engine (INT1)	22	Gauge Panel (GPA)	28	
7	3.28	0.75	W	E/G Emergency Stop Switch Signal	Inter Connector1 for Engine (INT1)	14	Gauge Panel (GPA)	29	
8	4.22	0.75	R	CAN2 High	Inter Connector1 for Engine (INT1)	3	Gauge Panel (GPA)	11	Twist Pair (4.23/4.22)
9	4.23	0.75	Brn	CAN2 Low	Inter Connector1 for Engine (INT1)	2	Gauge Panel (GPA)	12	Twist Pair (4.23/4.22)
10	1B	1.50	R	Alternator I	Inter Connector1 for Engine (INT1)	19	Gauge Panel (GPA)	13	
11	10R	1.50	R	Panel Power	Inter Connector1 for Engine (INT1)	17	Gauge Panel (GPA)	2	
12	13R	1.50	R	Panel Power	Inter Connector1 for Engine (INT1)	27	Gauge Panel (GPA)	3	
13	4.36	0.75	Brn	Key ON (T15)	Inter Connector1 for Engine (INT1)	20	Gauge Panel (GPA)	4	
14	4.31	0.75	W	Key Switch "START" (T50)	Inter Connector1 for Engine (INT1)	29	Gauge Panel (GPA)	1	
15	4.06	1.50	B	Panel GND	Inter Connector1 for Engine (INT1)	13	Gauge Panel (GPA)	24	
16	13B	1.50	B	Panel GND	Inter Connector1 for Engine (INT1)	6	Gauge Panel (GPA)	25	
17	7D	1.00	R	Gearbox Oil Press Sensor Supply (24V)	Inter Connector1 for Engine (INT1)	30	Gauge Panel (GPA)	14	
18	10A	0.75	Y	Fuel Leakage S/W Signal	Inter Connector1 for Engine (INT1)	10	Gauge Panel (GPA)	10	
19	24A	0.75	B	Fuel Leakage S/W GND	Inter Connector1 for Engine (INT1)	24	Gauge Panel (GPA)	33	

CAN Wires

No.	Wire Label	Size (mm ²)	Color	Circuit Description	From	No.	To	No.	Remark
1	2A	0.85	B	GND	CONN A	2	CONN B	2	Splice 2A
2	3A	0.85	R	CAN High	CONN A	3	CONN B	3	
3	4A	0.85	B	CAN Low	CONN A	4	CONN B	4	
4	2A-1	-		Shielding Wire	Shielding Wire		2A		Splice 2A
5	5A	0.85	R	Battery (+)	CONN A	5	CONN B	5	
6	6A	0.85	G	GND	CONN A	6	CONN B	6	

8.2. Switches and Sensors

8.2.1. Boost Pressure and Temperature Sensor

When the boost pressure and temperature sensor is installed on the intake manifold, it measures the absolute pressure and temperature inside the intake manifold.

The output signal is sent to the electronic control unit (ECU) which calculates the boost pressure based on the programmed characteristic curve.

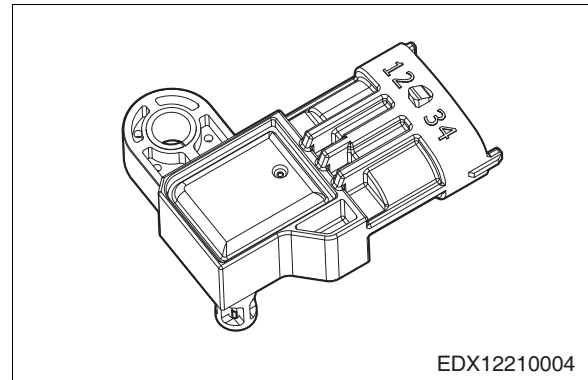

8.2.2. Crank Sensor

The position of the piston in the combustion chamber plays a very important role in fuel injection. All engine pistons are connected to the crankshaft by means of connecting rods. The crankshaft speed sensor installed in the flywheel housing provides information on the position of every piston.

The rotation speed is defined as the number of rotations of the crankshaft per minute, and the main input variables are calculated by the electronic control unit (ECU) using signals from the crankshaft speed sensor.

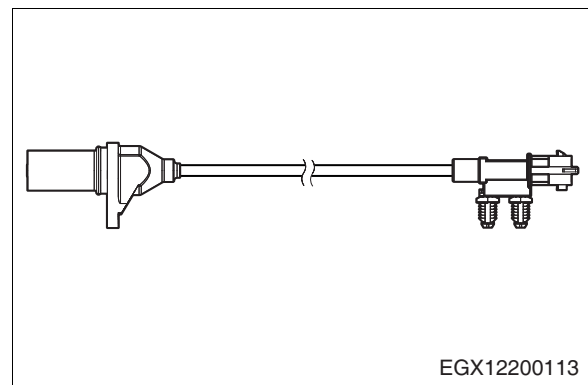

8.2.3. Common Rail Pressure Sensor

The common rail pressure sensor measures the pressure of fuel entering the common rail. This sensor, which converts the measured fuel pressure into an electrical signal, amplifies the measured signal and calculates the value in the electronic control unit (ECU).

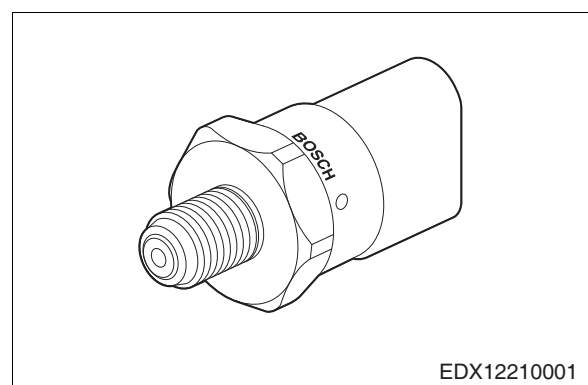

8.2.4. Coolant Temperature Sensor

The engine coolant temperature sensor detects the temperature of the engine coolant and conveys it to the electronic control unit (ECU).

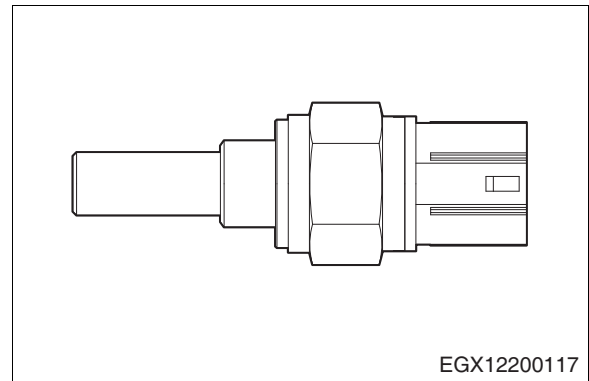

8.2.5. Cam Sensor

The cam sensor controls the engine's intake and exhaust valves. Rotating at half the speed of the crankshaft, this sensor determines whether the camshaft is on the compression stroke or exhaust stroke as the pistons move toward TDC.

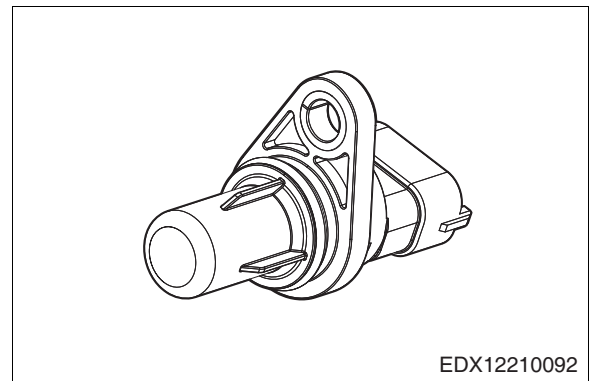

8.2.6. Exhaust Gas Temperature Sensor

The temperature sensor installed in the exhaust pipe measures the temperature of the engine exhaust gas and sends the data to the electronic control unit (ECU) where the value is calculated.

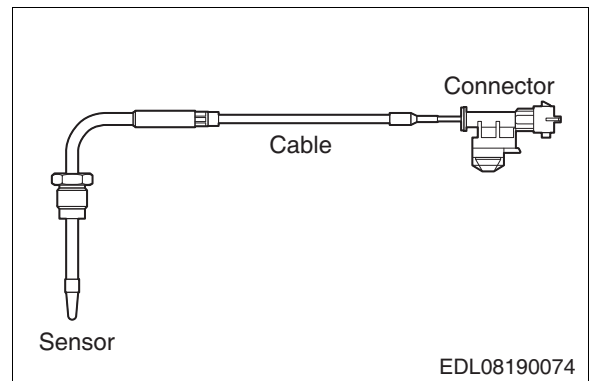

8.2.7. Oil Pressure Sensor

The temperature sensor installed in the exhaust pipe measures the temperature of the engine exhaust gas and sends the data to the electronic control unit (ECU) where the value is calculated.

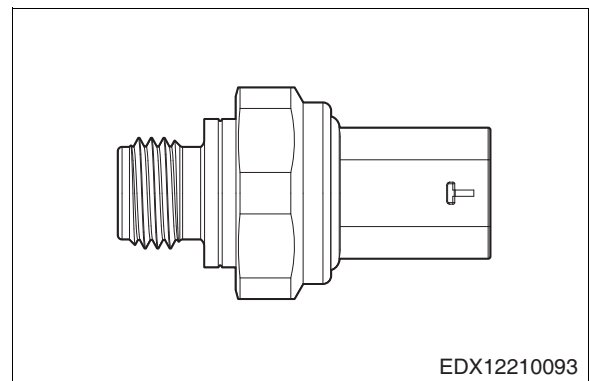

8.2.8. Oil Temperature Sensor

The engine oil temperature sensor detects the temperature of the engine oil and conveys it to the electronic control unit (ECU).

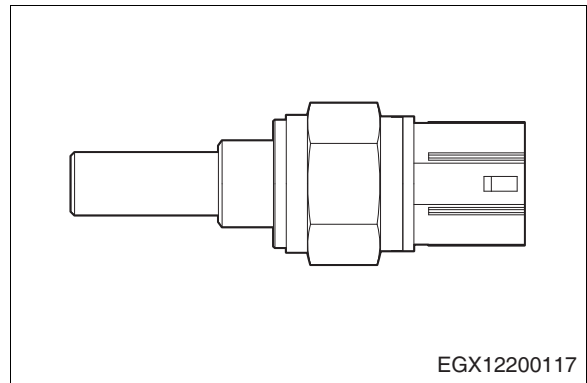

8.2.9. Aftertreatment Exhaust Gas Temperature Sensor

This sensor measures the temperature upstream/downstream of the selective catalytic reduction (SCR) unit and sends the data to the electronic control unit (ECU).

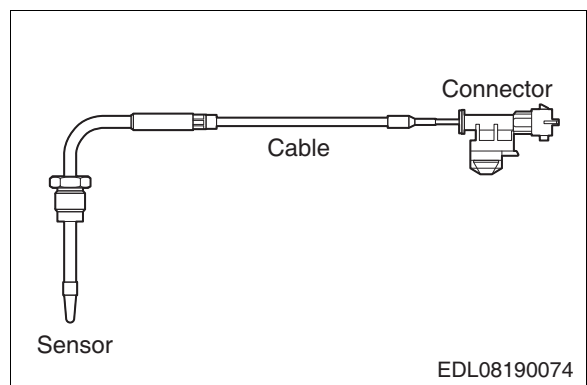

8.2.10. Urea Quality Sensor

This sensor measures the urea concentration, temperature, and level and sends the data to the electronic control unit (ECU). Installed on top of the urea tank, the sensor is connected to the coolant line to thaw the urea in cold weather.

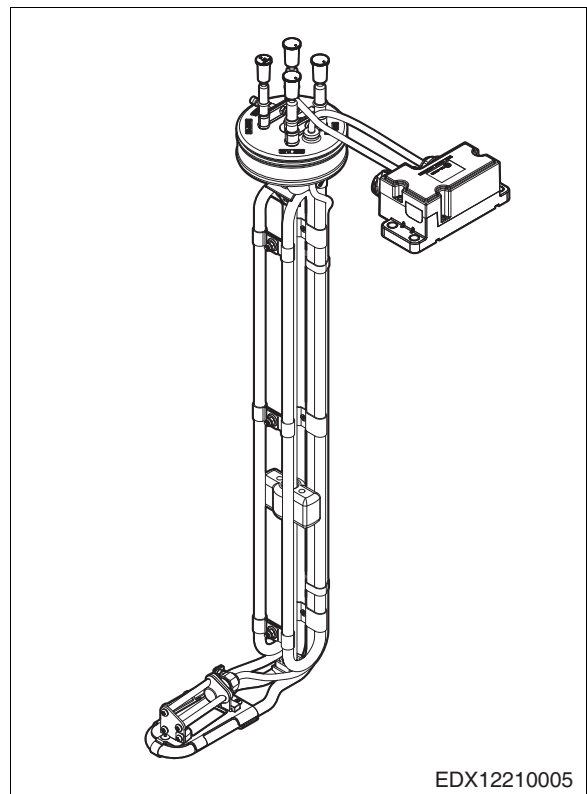

8.2.11. Fuel Temperature Sensor

The engine fuel temperature sensor detects the engine fuel temperature and conveys it to the electronic control unit (ECU).

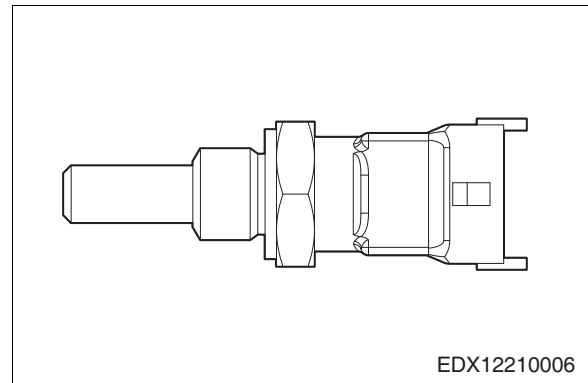

8.2.12. Differential Pressure Sensor

This sensor compares the pressure levels upstream/downstream of the selective catalytic reduction (SCR) unit, detects whether there is any clogging based on changes in the differential pressure within the selective catalytic reduction (SCR) unit, and sends the data to the electronic control unit (ECU).

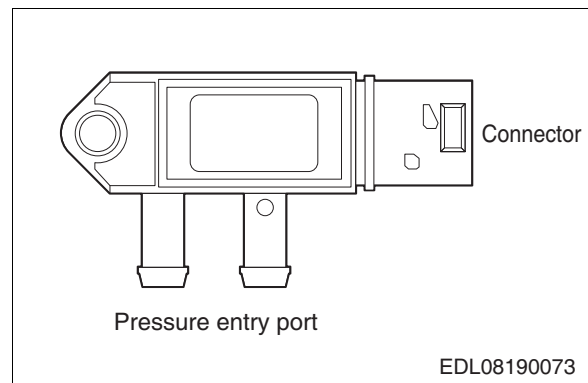

8.2.13. NOx Sensor

This sensor measures the amount of NOx based on the amount of oxygen in the exhaust gas and relays the data to the electronic control unit (ECU).
The sensor measures downstream of the selective catalytic reduction (SCR) system.

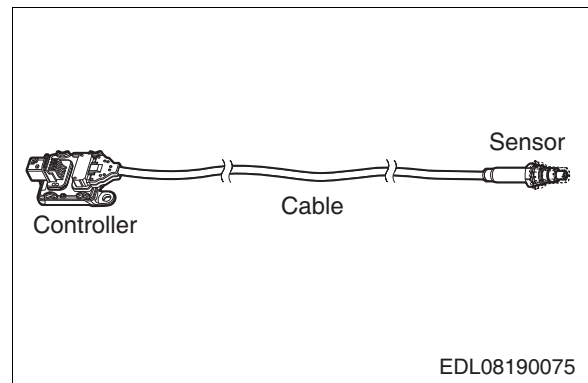

8.2.14. Ambient Temperature Sensor

This sensor measures the ambient temperature around the engine and relays the data to the electronic control unit (ECU).
The sensor measures the engine's ambient temperature in order to determine when to activate the NOx sensor.

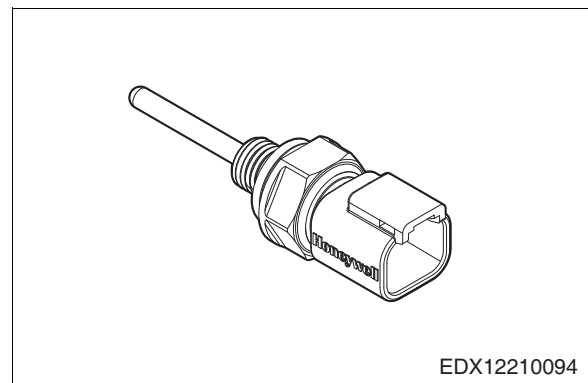

8.2.15. Position Sensor

This sensor measures the amount of movement of the control lever in the steering room and sends the data to the electronic control unit (ECU).

The electronic control unit (ECU) adjusts the engine rpm based on the output value of the position sensor.

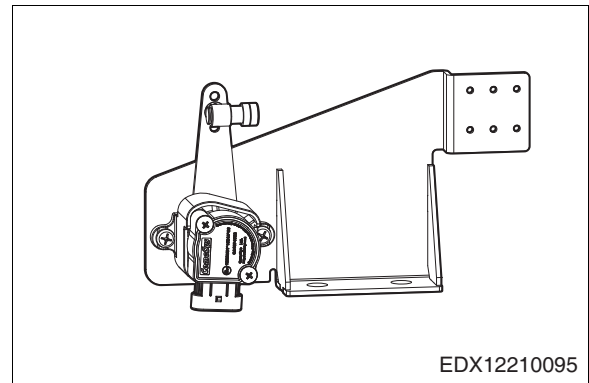

8.3. Engine Control Unit (ECU)

8.3.1. Engine Control Unit (ECU) Connectors

Engine control unit (ECU) connectors consist of connectors for connecting to the ship and connectors for connecting to the engine.

- ECU assembly
 - 1) Secure the ECU mounting plate.
 - 2) Install the ECU.

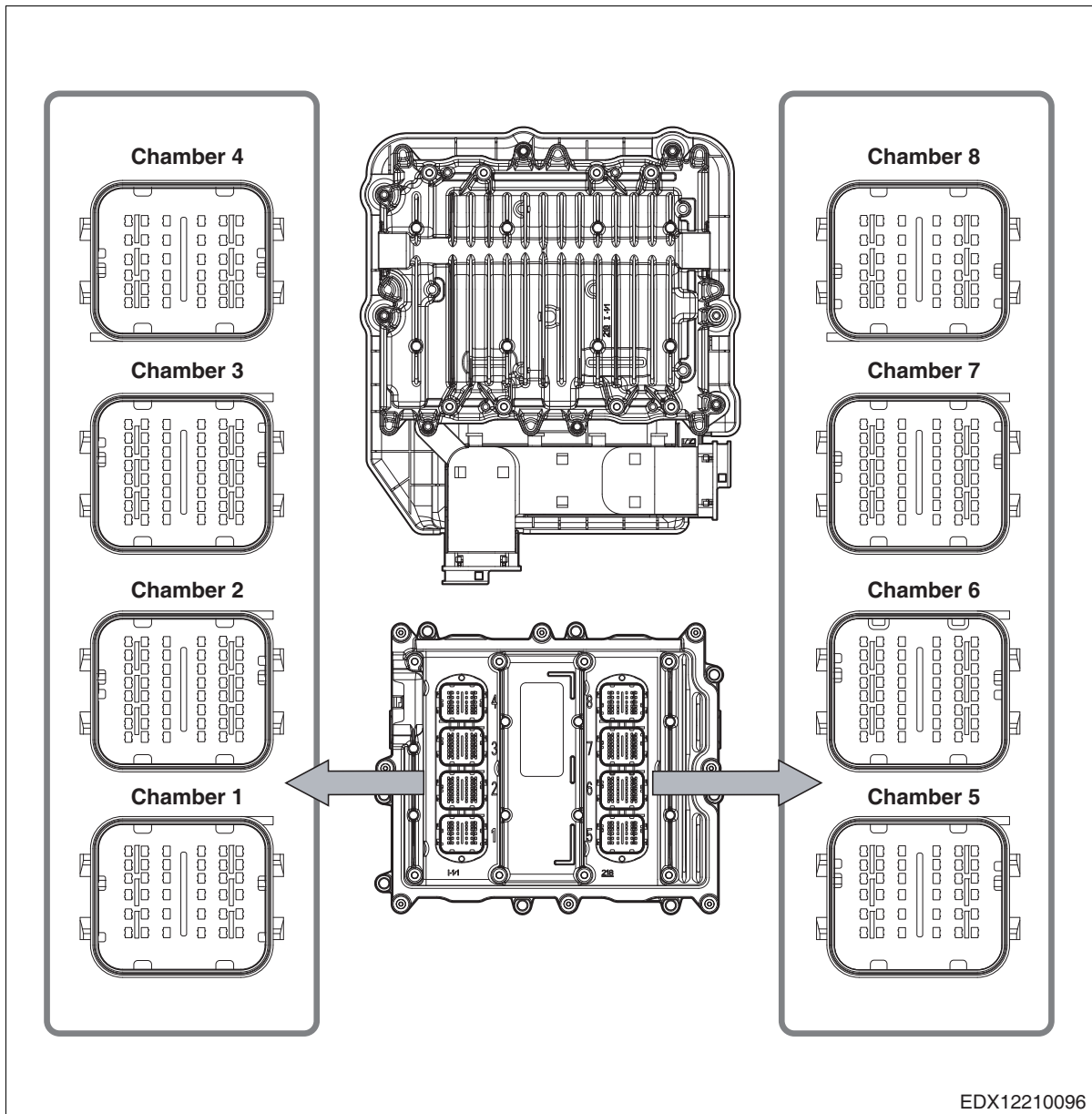

8.3.2. Engine Control Unit (ECU) Input/Output

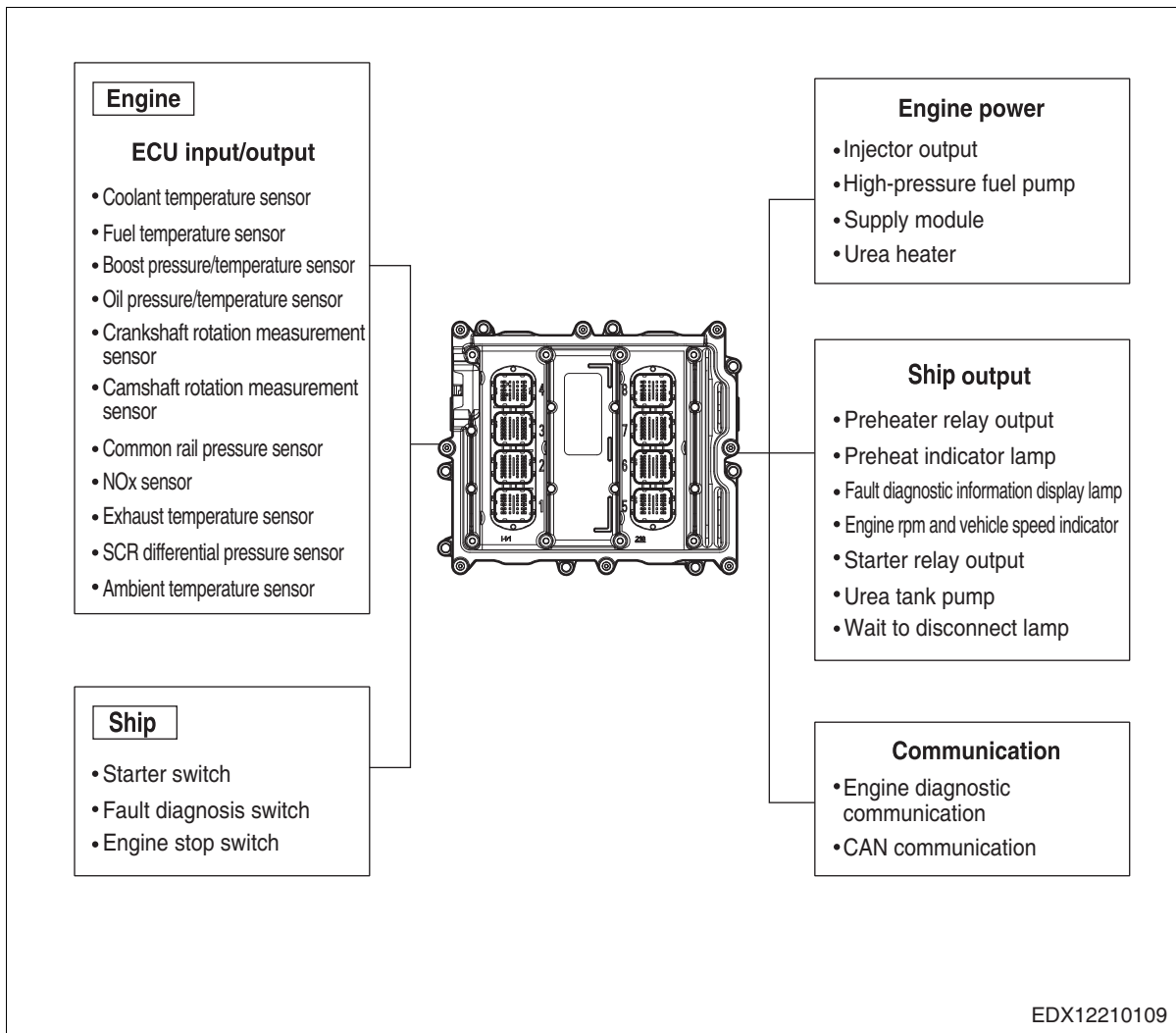

8.3.3. Engine Control Unit (ECU) Operating Conditions

- 1) Starting the engine
 - a) To set the reference temperature for determining whether or not to perform preheating, the ECU sets the lowest temperature among the coolant temperature, fuel temperature, intake air temperature, and oil temperature as the reference temperature.
 - b) To set the reference temperature for determining the amount of fuel, the ECU sets the engine coolant temperature as the reference temperature.
 - c) After determining a suitable amount of fuel for starting the engine, the ECU supplies the fuel to the engine and uses the crankshaft speed sensor to measure the engine rpm signal.
- 2) Sailing
 - a) It calculates essential data required for sailing, such as CAN data received from the ship control unit and the engine rpm, etc..
- 3) Adjusting the engine rpm to the needs of the driver
 - a) The ECU controls the engine rpm according to the needs of the driver and controls the engine according to the engine rpm required by the vehicle control unit.
- 4) Failure Diagnosis
 - a) The fault diagnosis information lamp on the gauge panel activates in the event of a fault.
 - b) The fault diagnosis information lamp can be used to check the fault code.



CAUTION

It can also be checked using the fault diagnosis information on the gauge panel.

- c) The type of fault can be diagnosed by connecting a diagnostic tool to the check connector on the back of the driver's seat.
- 5) Sailing record
 - a) Sailing-related information is recorded in the engine control unit.
 - b) Information such as the fuel consumption rate, engine operating time, and engine control unit operating time is recorded in the engine control unit.
 - c) Information can be monitored using the ECU diagnostic system.

8.4. TMS 3.0 (Option)

8.4.1. Outside Drawing

● TMS 3.0 TYPE A (LTE)

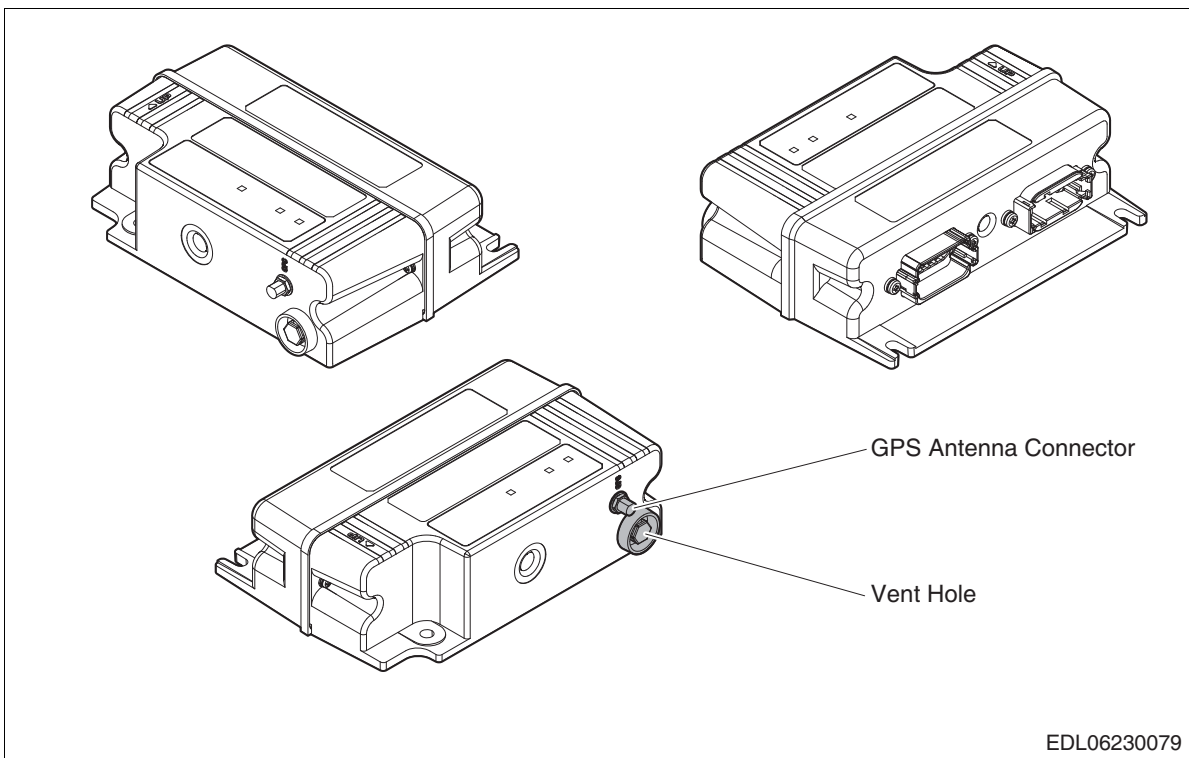

● TMS 3.0 TYPE B (LTE+SAT)

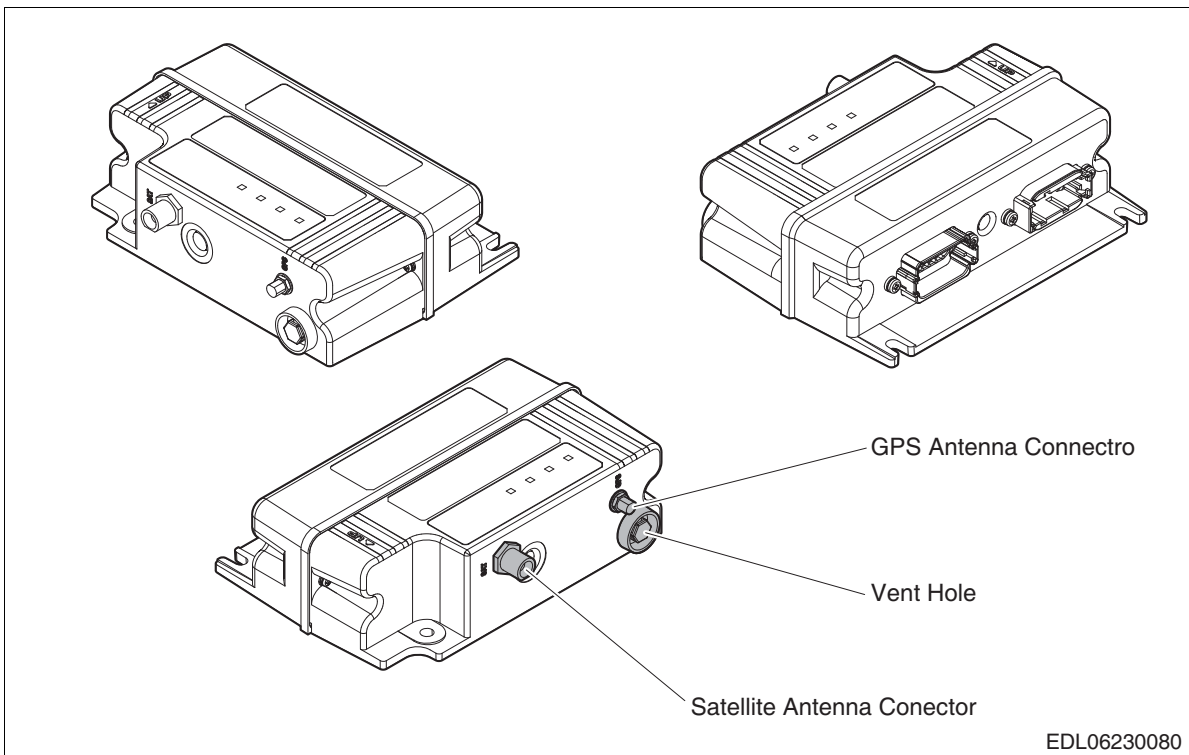

8.4.2. Front PIN Map

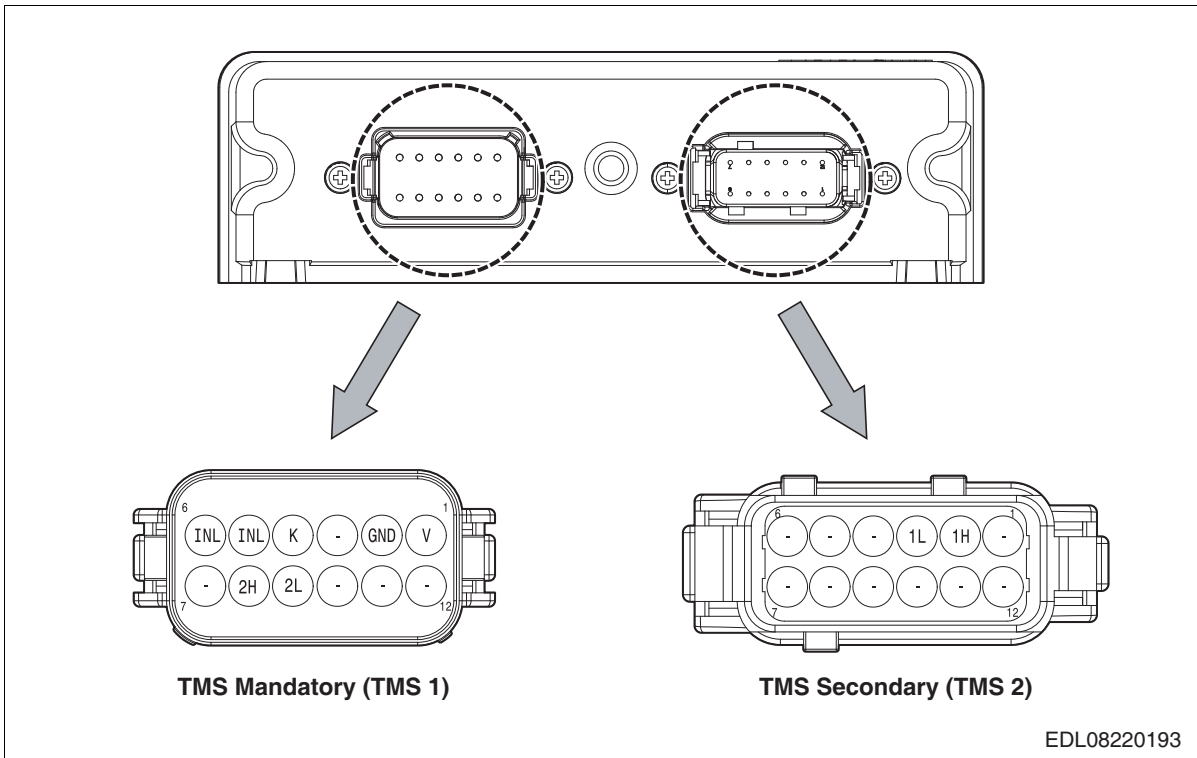

No.	Circuit Description	Description
1	V	Power (24V)
2	GND	Ground
4	K	Key On
8	2H	CAN 2H
9	2L	CAN 2L

No.	Circuit Description	Description
2	1H	CAN 1H
3	1L	CAN 1L

8.4.3. TMS 3.0 TYPE A (LTE) Module (EG25-G) Specification

- 1) Key Benefits
 - LTE Cat 4 Module (Max 150 Mbps (DL), Max 50 Mbps (UL))
Worldwide LTE, UMTS/HSPA (+) and GSM/GPRS/EDGE coverage
 - Pin Compatible with EG25-X/EC20
- 2) Supported Frequency Bands
 - a) LTE-FDD: B1/B2/B3/B4/B5/B7/B8/B12/B13/B18/B19/B20/B25/B26/B28
 - b) LTE-TDD: B38/B39/B40/B41
 - c) WCDMA: B1/B2/B4/B5/B6/B8/B19
 - d) GSM: 850/900/1,800/1,900 MHz
- 3) Internet Protocol Features
 - a) Support TCP/UDP//PPP/FTP/HTTP/HTTPS/NTP/PING/QMI/NITZ
SMTP/SPI/MQTT/CMUX/SMTPS protocols
- 4) Key Features
 - a) (U)SIM Interface: Support USIM/SIM card: 1.8V, 3.3V
 - b) Rx-diversity: Support LTE/WCDMA Rx-diversity
 - c) Antenna Indication: ANT_MAIN(Main antenna interface)
ANT_DIV(Rx-diversity antenna interface)
 - d) Physical Characteristics
 - Size: 29.0 (±0.15 mm) x 32.0 (±0.15 mm) x 2.4 (±0.2 mm)
 - Package: LGA
 - Weight: approx.4.9g
 - e) Temperature Range: -40°C to +85°C
- 5) Approvals
 - a) Carrier:
 - Deutsche Telekom (Europe)
 - Verizon/AT&T/Sprint/U.S. Cellular/T-Mobile* (North America)
 - Telus/Rogers* (Canada)
 - b) Regulatory:
 - GCF (Global)
 - CE (Europe)
 - FCC/PTCRB (North America)
 - IC (Canada)
 - Anatel (Brazil)
 - IFETEL (Mexico)
 - SRRC/CCC/NAL (China)
 - KC (South korea)
 - NCC (Taiwan, China)
 - RCM (Australia & New Zealand)
 - FAC* (Russia)
 - NBTC (Thailand)
 - IMDA (Singapore)
 - ICASA (South Africa)
 - c) Others:
 - RoHS
 - WHQL

8.4.4. Schematic diagram

- TMS 3.0

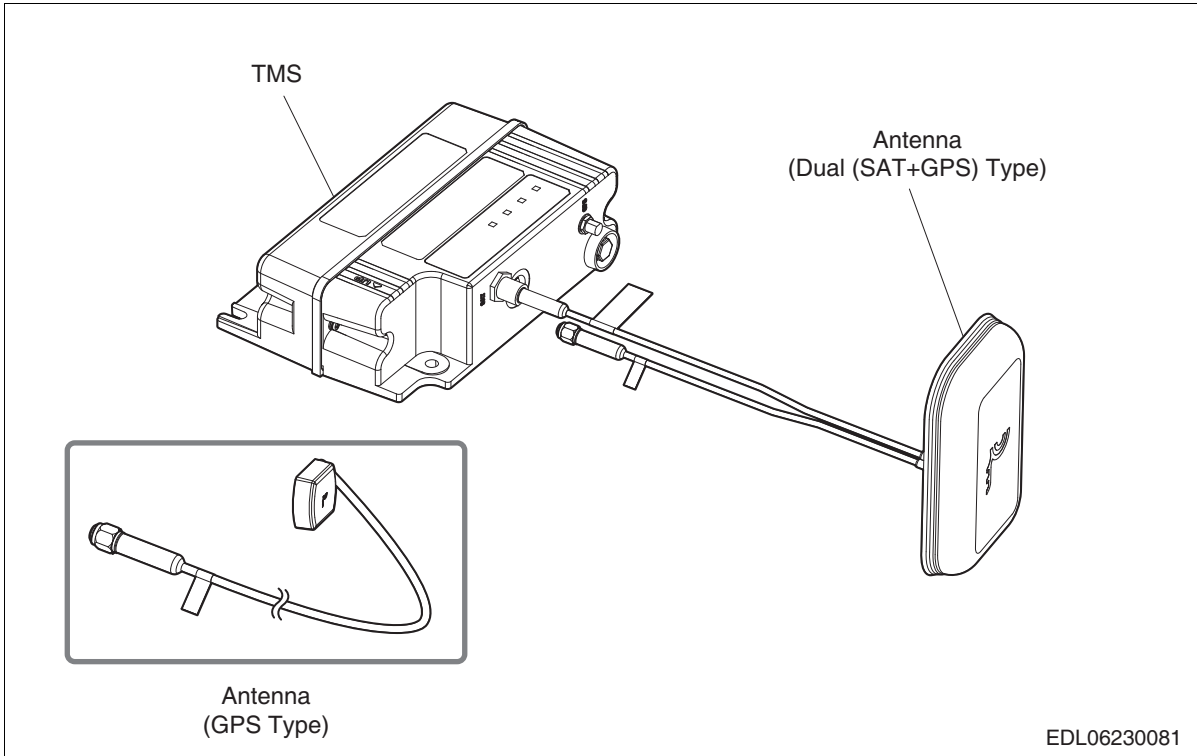

8.4.5. Connect DGP (Digital Gage Panel) and TMS cable

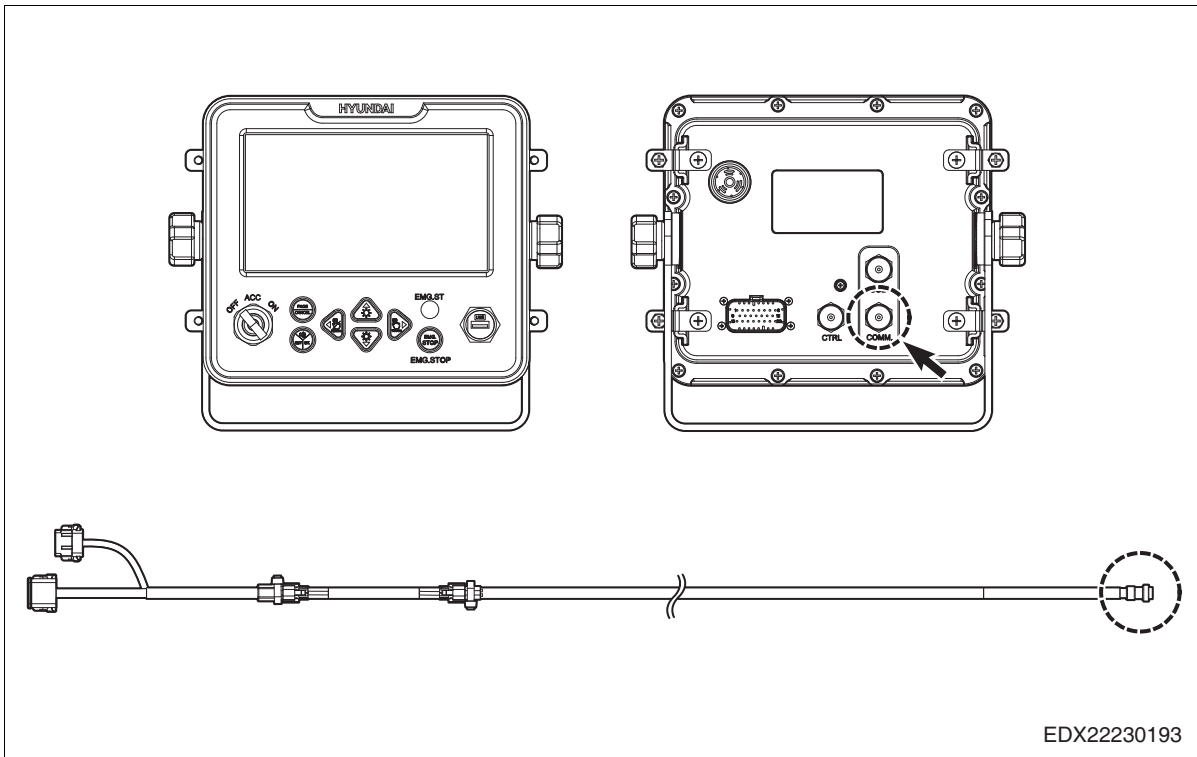

Note
TMS cable size: 2 m, 3 m, 5 m, 7.5m

8.5. Starter Motor



CAUTION

Do not dispose of the battery anywhere with flames around. Discard it in a designated place.

Do not dispose of the battery in a place which could pollute the environment, such as streams, rivers and mountains.

Seal the battery and dispose of it as far away as possible so that it cannot be reused.

HD Hyundai Infracore is not responsible for problems arising as a result of the user arbitrarily disassembling parts or problems arising due to changes made to the structure of the product without prior consent from HD Hyundai Infracore.

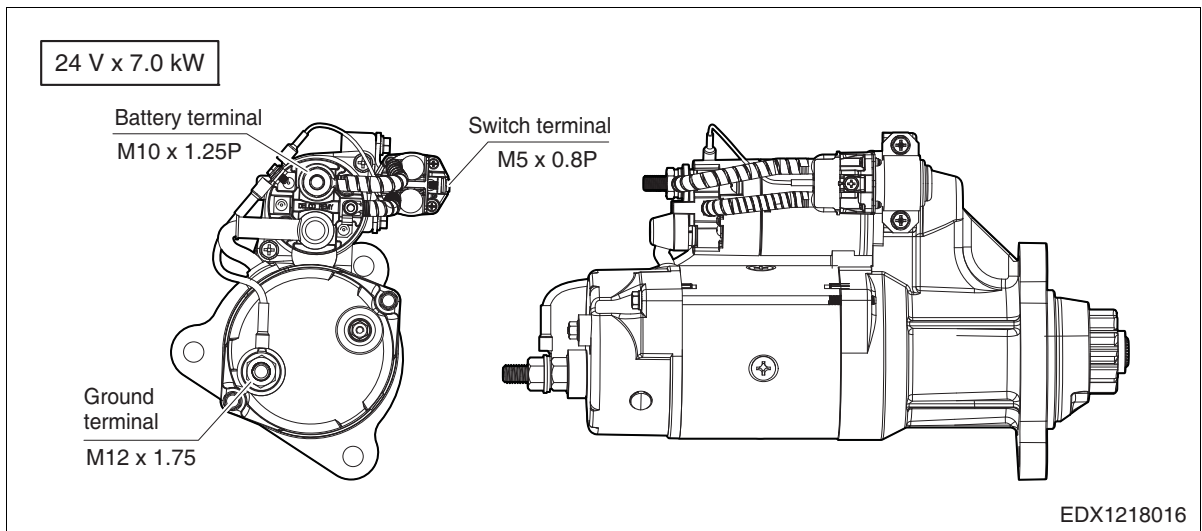

The starter motor is installed on the back left side of the flywheel. When servicing the engine, soak the starter motor pinion and ring gear in fuel and clean them thoroughly with a brush. Then, apply grease to them to prevent rust.

When cleaning the starter motor, take particular care to ensure that moisture does not enter the wiring and cause a short circuit.



CAUTION

The starter motor should always be protected from moisture.



WARNING

Before working on the electrical systems, disconnect the negative ("-") battery cable.

To prevent a short circuit while working, reconnect the cable after the work is complete.

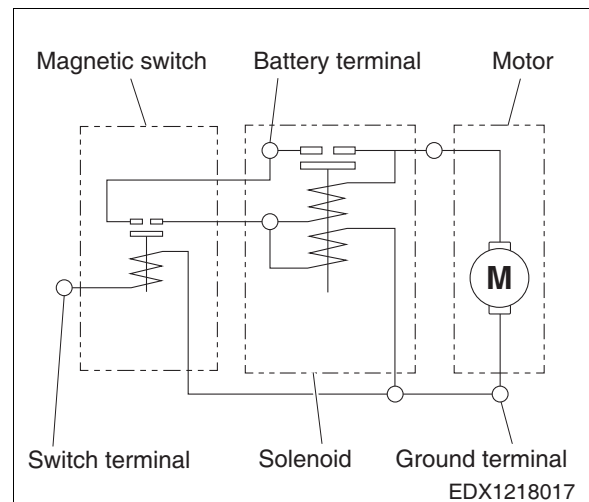

8.6. Alternator

The alternator is equipped with a silicon rectifier. The transistor-type regulator installed in the body of the alternator restricts the voltage of the alternator. In order to prevent damage to the rectifier and regulator, do not run the alternator unless the regulator and battery are connected to the circuit.

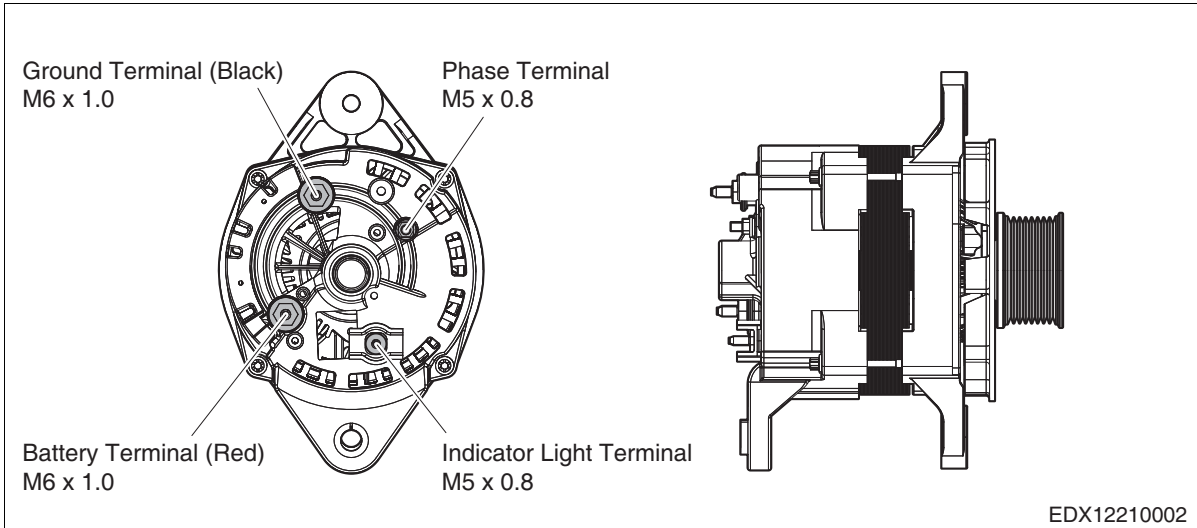

CAUTION

The alternator does not require maintenance, but it must be protected from dust, moisture and water.

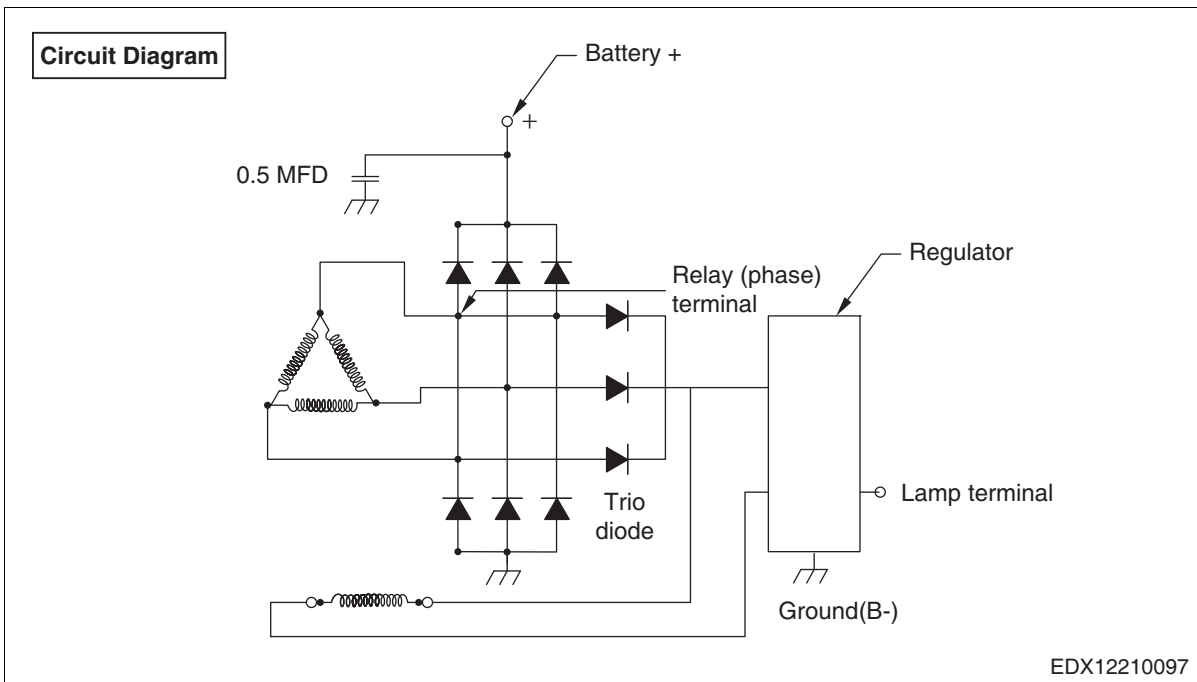

CAUTION

Run the alternator in accordance with the guidelines provided in this chapter.

8.7. Fault Code List

No.	Fault	P-Code	SPN	FMI	EnvRef	Shut-down	Torque Limit	Speed Limit	Description
1	ARlySCB_6	P270C	520903	3	xSet2	OFF	OFF	OFF	Short circuit to battery error at ECU internal relay 6 (DEF tank coolant valve/DEF hos line heater)
2	ARlySCB_7	P270D	520904	3	xSet2	OFF	OFF	OFF	Short circuit to battery error at ECU internal relay 7 (Engine stop switch/DEF overflow lamp/ECU on lamp)
3	ARlySCB_8	P270E	520905	3	xSet14	OFF	OFF	OFF	Short circuit to battery error at ECU internal relay 8 (Supply module/reverting valve)
4	ARlySCG_6	P271C	520908	4	xSet2	OFF	OFF	OFF	Short circuit to ground error at ECU internal relay 6 (DEF tank coolant valve/DEF hos line heater)
5	ARlySCG_7	P271D	520909	4	xSet2	OFF	OFF	OFF	Short circuit to ground error at ECU internal relay 7 (Engine stop switch/DEF overflow lamp/ECU on lamp)
6	ARlySCG_8	P271E	520910	4	xSet14	OFF	OFF	OFF	Short circuit to ground error at ECU internal relay 8 (Supply module/reverting valve)
7	BattUHi	P0563	158	0	xSet2	OFF	OFF	OFF	High battery voltage error
8	BattULo	P0562	158	1	xSet2	OFF	OFF	OFF	Low battery voltage error
9	BattUSRCMax	P1563	158	3	xSet2	OFF	OFF	OFF	High voltage error for battery sensor
10	BattUSRCMin	P1562	158	4	xSet2	OFF	OFF	OFF	Low voltage error for battery sensor
11	CEngDsTOVerT1	P2185	110	2	xSet5	OFF	OFF	OFF	High coolant temperature error (Alarm)
12	CEngDsTPhysRngHi	P0116	110	0	xSet5	ON	OFF	OFF	High coolant temperature error
13	CEngDsTSRCMax	P0118	110	3	xSet5	OFF	50% ↓	200rpm ↓	High voltage error for coolant temperature sensor
14	CEngDsTSRCMin	P1119	110	4	xSet5	OFF	50% ↓	200rpm ↓	Low voltage error for coolant temperature sensor
15	ComCSTSC1TE	U0130	520214	0	xSet2	OFF	OFF	OFF	CAN communication check sum error of TSC1TE(TCU)
16	ComToA1DEFI	U0105	520824	12	xSet15	OFF	OFF	OFF	CAN communication timeout error of A1DEFI (DEF Tank)
17	ComToAT1OG1	U029E	520657	12	xSet2	OFF	OFF	OFF	CAN communication timeout error of downstream NOx sensor
18	ComToAT1T1I	U0110	520201	12	xSet2	OFF	OFF	OFF	CAN communication timeout error of AT1T1I
19	ComToSMVCU	U0107	520823	12	xSet2	OFF	OFF	OFF	CAN communication timeout error of SMVCU(VCU)
20	ComToTSC1TE	U0132	520214	12	xSet2	OFF	OFF	OFF	CAN communication timeout error of TSC1TE(TCU)
21	DevLibBattUHi	P1564	520616	3	xSet2	OFF	OFF	OFF	Disabled powerstage diagnostic error due to high battery voltage
22	DevLibBattULo	P1565	520616	4	xSet2	OFF	OFF	OFF	Disabled powerstage diagnostic error due to low battery voltage
23	ECBtnStopSig	P1102	970	12	xSet2	OFF	OFF	OFF	Emergency stop switch stuck error
24	EcuOnLampOL	P1161	520923	5	xSet2	OFF	OFF	OFF	Open circuit error for ECU on lamp
25	EcuOnLampSCB	P1162	520924	3	xSet2	OFF	OFF	OFF	Short circuit to battery error for ECU on lamp
26	EcuOnLampSCG	P1163	520925	4	xSet2	OFF	OFF	OFF	Short circuit to ground error for ECU on lamp
27	EngPrtOvrSpd	P0219	606	0	xSet2	ON	OFF	OFF	Engine overspeed detection error
28	EnvTPhysRngHi	P0071	171	0	xSet11	OFF	OFF	OFF	High environment temperature error
29	EnvTSRCMax	P0073	171	3	xSet11	OFF	OFF	OFF	High voltage error for environment temperature sensor
30	EnvTSRCMin	P0072	171	4	xSet11	OFF	OFF	OFF	Low voltage error for environment temperature sensor
31	EpmCaSI1ErrSig	P0341	520200	0	xSet30	OFF	50% ↓	200rpm ↓	Disturbed camshaft signal error
32	EpmCaSI1NoSig	P0340	520200	2	xSet30	OFF	50% ↓	200rpm ↓	No camshaft signal error
33	EpmCaSI1OfsErr	P1212	520224	12	xSet30	OFF	50% ↓	200rpm ↓	Camshaft signal offset error
34	EpmCrSErrSig	P0336	520199	0	xSet29	OFF	OFF	OFF	Disturbed crankshaft signal error
35	EpmCrSNoSig	P0335	520199	2	xSet29	OFF	OFF	OFF	No crankshaft signal error
36	FuelTPhysRngHi	P0181	174	0	xSet6	OFF	50% ↓	200rpm ↓	High fuel temperature error
37	FuelTSRCMax	P0183	174	3	xSet6	OFF	OFF	OFF	High voltage error for fuel temperature sensor

No.	Fault	P-Code	SPN	FMI	EnvRef	Shut-down	Torque Limit	Speed Limit	Description
38	FuelTSRCMin	P0182	174	4	xSet6	OFF	OFF	OFF	Low voltage error for fuel temperature sensor
39	HegnMntgPlausS4B1	P1206	520795	12	xSet28	OFF	OFF	OFF	Detection error of not correctly mounted downstream NOx sensor
40	InjVlv_DI_DcDc	P062B	520693	0	xSet38	OFF	OFF	OFF	Low Injector booster voltage error
41	InjVlv_DI_NoLd_0	P0201	734	5	xSet38	OFF	OFF	OFF	Open circuit error of injector 1 powerstage
42	InjVlv_DI_NoLd_1	P0202	735	5	xSet38	OFF	OFF	OFF	Open circuit error of injector 5 powerstage
43	InjVlv_DI_NoLd_2	P0203	736	5	xSet38	OFF	OFF	OFF	Open circuit error of injector 3 powerstage
44	InjVlv_DI_NoLd_3	P0204	737	5	xSet38	OFF	OFF	OFF	Open circuit error of injector 6 powerstage
45	InjVlv_DI_NoLd_4	P0205	738	5	xSet38	OFF	OFF	OFF	Open circuit error of injector 2 powerstage
46	InjVlv_DI_NoLd_5	P120B	739	5	xSet38	OFF	OFF	OFF	Open circuit error of injector 4 powerstage
47	InjVlv_DI_ScBnk_0	P162E	520626	3	xSet38	OFF	OFF	OFF	Short circuit to battery error for injection bank1 power stage
48	InjVlv_DI_ScBnk_1	P1209	520691	3	xSet38	OFF	OFF	OFF	Short circuit to battery error for injection bank2 power stage
49	InjVlv_DI_ScCyl_0	P0262	734	4	xSet38	OFF	OFF	OFF	Short circuit to ground error for injector 1 low-side powerstage
50	InjVlv_DI_ScCyl_1	P0265	735	4	xSet38	OFF	OFF	OFF	Short circuit to ground error for injector 5 low-side powerstage
51	InjVlv_DI_ScCyl_2	P0268	736	4	xSet38	OFF	OFF	OFF	Short circuit to ground error for injector 3 low-side powerstage
52	InjVlv_DI_ScCyl_3	P0271	737	4	xSet38	OFF	OFF	OFF	Short circuit to ground error for injector 6 low-side powerstage
53	InjVlv_DI_ScCyl_4	P0274	738	4	xSet38	OFF	OFF	OFF	Short circuit to ground error for injector 2 low-side powerstage
54	InjVlv_DI_ScCyl_5	P1277	739	4	xSet38	OFF	OFF	OFF	Short circuit to ground error for injector 4 low-side powerstage
55	InjVlv_DI_ScHsLs_0	P086A	734	12	xSet38	OFF	OFF	OFF	Short circuit error between highside and low-side of the power stage 0(cylinder 1)
56	InjVlv_DI_ScHsLs_1	P086B	735	12	xSet38	OFF	OFF	OFF	Short circuit error between highside and low-side of the power stage1(cylinder 5)
57	InjVlv_DI_ScHsLs_2	P086C	736	12	xSet38	OFF	OFF	OFF	Short circuit error between highside and low-side of the power stage2 (cylinder 3)
58	InjVlv_DI_ScHsLs_3	P086D	737	12	xSet38	OFF	OFF	OFF	Short circuit error between highside and low-side of the power stage3 (cylinder 6)
59	InjVlv_DI_ScHsLs_4	P086E	738	12	xSet38	OFF	OFF	OFF	Short circuit error between highside and low-side of the power stage4 (cylinder 2)
60	InjVlv_DI_ScHsLs_5	P086F	739	12	xSet38	OFF	OFF	OFF	Short circuit error between highside and low-side of the power stage5 (cylinder 4)
61	IVAdjDialIVAdj_0	P268C	520813	2	xSet2	OFF	OFF	OFF	Injector 1 adjustment value error
62	IVAdjDialIVAdj_1	P2690	520814	2	xSet2	OFF	OFF	OFF	Injector 5 adjustment value error
63	IVAdjDialIVAdj_2	P268E	520815	2	xSet2	OFF	OFF	OFF	Injector 3 adjustment value error
64	IVAdjDialIVAdj_3	P2691	520816	2	xSet2	OFF	OFF	OFF	Injector 6 adjustment value error
65	IVAdjDialIVAdj_4	P268D	520817	2	xSet2	OFF	OFF	OFF	Injector 2 adjustment value error
66	IVAdjDialIVAdj_5	P268F	520818	2	xSet2	OFF	OFF	OFF	Injector 4 adjustment value error
67	MeUnNoDiagInfo	P125A	157	2	xSet31	OFF	50% ↓	200rpm ↓	No information error of the metering unit power stage
68	MeUnOIHsLs	P0255	520694	5	xSet31	OFF	OFF	OFF	Open circuit error of the metering unit
69	MeUnScbHs	P0254	520694	3	xSet31	OFF	OFF	OFF	Short circuit to battery error on high side of the metering unit
70	MeUnScbLs	P1254	520695	3	xSet31	OFF	OFF	OFF	Short circuit to battery error on low side of the metering unit
71	MeUnScgHs	P0253	520694	4	xSet31	OFF	OFF	OFF	Short circuit to ground error on high side of the metering unit
72	MeUnScgLs	P1253	520695	4	xSet31	OFF	50% ↓	200rpm ↓	Short circuit to ground error on low side of the metering unit
73	MeUnScHsLs	P0256	520694	12	xSet31	OFF	OFF	OFF	Short circuit error between high side and low side of the metering unit
74	OilPSwmpPhysRngLo	P1521	100	1	xSet7	ON	OFF	OFF	Low oil pressure error
75	OilPSwmpSRCMax	P1522	100	3	xSet7	OFF	50% ↓	200rpm ↓	High voltage error for oil pressure sensor
76	OilPSwmpSRCMin	P1523	100	4	xSet7	OFF	50% ↓	200rpm ↓	Low voltage error for oil pressure sensor

No.	Fault	P-Code	SPN	FMI	EnvRef	Shut-down	Torque Limit	Speed Limit	Description
77	OilPhysRngHi	P0196	175	0	xSet8	OFF	50% ↓	200rpm ↓	High oil temperature error
78	OilTSRCMax	P0198	175	3	xSet8	OFF	OFF	OFF	High voltage error for oil temperature sensor
79	OilTSRCMin	P0197	175	4	xSet8	OFF	OFF	OFF	Low voltage error for oil temperature sensor
80	PCRGovDvtMax	P2263	5465	0	xSet13	OFF	50% ↓	200rpm ↓	Under boost pressure error(air leakage)
81	PCRGovDvtMin	P1263	5465	1	xSet13	OFF	OFF	OFF	Over boost pressure error(blocked)
82	PEnvRngChkMax	P2227	108	0	xSet13	OFF	OFF	OFF	High atmospheric pressure error
83	PEnvRngChkMin	P1227	108	1	xSet13	OFF	OFF	OFF	Low atmospheric pressure error
84	PEnvSigRngMax	P2229	108	3	xSet13	OFF	OFF	OFF	High voltage atmospheric pressure sensor
85	PEnvSigRngMin	P2228	108	4	xSet13	OFF	OFF	OFF	Low voltage atmospheric pressure sensor
86	PEnvSnsrPlaus	P006D	108	12	xSet13	OFF	OFF	OFF	Atmospheric pressure sensor plausibility error
87	PFItCharPDiffMax	P1457	520621	0	xSet18	OFF	50% ↓	200rpm ↓	Maximum SCR differential pressure error
88	PFItCharPDiffMin	P1456	520621	1	xSet18	OFF	OFF	OFF	Minimum SCR differential pressure error
89	PlntkVUsLineHiB1	P0238	102	3	xSet9	OFF	OFF	OFF	High voltage error for boost pressure sensor
90	PlntkVUsLineLoB1	P0237	102	4	xSet9	OFF	OFF	OFF	Low voltage error for boost pressure sensor
91	PlntkVUsPhysRngHi	P0236	102	0	xSet9	OFF	OFF	OFF	High boost pressure error
92	PPFitDiffSRCMax	P2465	4767	3	xSet18	OFF	OFF	OFF	High voltage error for SCR differential pressure sensor
93	PPFitDiffSRCMin	P2464	4767	4	xSet18	OFF	OFF	OFF	Low voltage error for SCR differential pressure sensor
94	PRVctOpnMax	P0089	520203	12	xSet33	OFF	OFF	OFF	Maximum opening counter excess error of pressure relief valve
95	PRVFrOpnPresInc	P108C	520709	12	xSet33	OFF	OFF	OFF	Forced opening error of pressure relief valve by pressure increase
96	PRVFrOpnPresShck	P108D	520710	12	xSet33	ON	OFF	OFF	Forced opening error of pressure relief valve by pressure shock
97	PRVOpn	P108E	520711	7	xSet33	OFF	50% ↓	200rpm ↓	Open error of pressure relief valve
98	PRVQBalChk	P1036	520712	12	xSet33	OFF	OFF	OFF	Quantity balance check if a successful pressure relief valve opening is ensured
99	PRVRPOutOfRng	P1037	520713	12	xSet33	OFF	OFF	OFF	Out of tolerance rage error of averaged rail pressure
100	PRVtiOpnMax	P108F	520714	12	xSet33	OFF	OFF	OFF	Maximum allowed opening time excess error of pressure relief valve
101	PRVUnExptRailPDRp	P0194	129	5	xSet4	OFF	OFF	OFF	Unexpected rail pressure drop error
102	RailMeUn0	P0251	520196	12	xSet4	OFF	50% ↓	200rpm ↓	Maximum positive deviation excess error of rail pressure (Fuel leakage)
103	RailMeUn10	P1251	520715	12	xSet4	OFF	50% ↓	200rpm ↓	Leakage detection error of balancing the fuel volumes flows (leakage)
104	RailMeUn2	P1252	520716	12	xSet4	OFF	50% ↓	200rpm ↓	Maximum negative rail pressure deviation excess error(blocked)
105	RailMeUn3	P0087	520717	12	xSet4	ON	50% ↓	200rpm ↓	Monitoring error for rail pressure
106	RailMeUn4	P1090	520719	12	xSet4	OFF	50% ↓	200rpm ↓	Maximum rail pressure excess error
107	RailMeUn7	P1050	520720	12	xSet4	OFF	50% ↓	200rpm ↓	Rail pressure setpoint plausibility error in over-run mode
108	RailMeUn8	P1257	520721	12	xSet4	OFF	50% ↓	200rpm ↓	Plausibility error of the volume flow of the metering unit at low idle
109	RailPCVLimpExtd4	P1192	520722	12	xSet4	ON	OFF	OFF	Monitoring error for maximum rail pressure in limp home mode
110	RailPGradMon	P1039	520702	2	xSet4	OFF	OFF	OFF	Rail pressure gradient monitoring error
111	RailPOfsTstMax	P0191	129	0	xSet4	OFF	50% ↓	200rpm ↓	Maximum offset excess error of the rail pressure sensor
112	RailPOfsTstMin	P1191	129	1	xSet4	OFF	50% ↓	200rpm ↓	Minimum offset of the rail pressure excess error
113	RailPSRCMax	P0193	129	3	xSet3	OFF	OFF	OFF	High voltage error of the rail pressure sensor
114	RailPSRCMin	P0192	129	4	xSet3	OFF	OFF	OFF	Low voltage error of the rail pressure sensor
115	RBA_IOEXTLIB_KEE-PALIVE_DRV	P1123	520111	0	xSet2	OFF	OFF	OFF	KeepAlive error during runtime at an external device
116	RBA_IOEXTLIB_KEE-PALIVE_INI	P1124	520111	1	xSet2	OFF	OFF	OFF	KeepAlive error during initialization phase at an external device

No.	Fault	P-Code	SPN	FMI	EnvRef	Shut-down	Torque Limit	Speed Limit	Description
117	rba_IoSigRtc_Stop-Counter	P1125	520112	2	xSet2	OFF	OFF	OFF	StopCounter counts slower/faster than allowed or no communication with counter possible
118	rba_MemDiag_Mem-ReadErr	P1126	520113	0	xSet2	OFF	OFF	OFF	Read diagnosis for ECU non volatile memory
119	rba_MemDiag_Mem-WrErr	P1127	520113	1	xSet2	OFF	OFF	OFF	Write diagnosis for ECU non volatile memory
120	rba_MRly_Diag_Stk_Event	P1128	520114	0	xSet2	OFF	OFF	OFF	Sticky Main - ECU relay error
121	rba_MultiStackTrace_Threshold	P1129	520115	0	xSet2	OFF	OFF	OFF	ECU stack memory threshold overrun
122	rba_SyC_IrrSwOffTrigEngRun_Event	P1130	520116	0	xSet2	OFF	OFF	OFF	ECU observation counter irregular switch off counter triggered by engine running
123	SCRChkEta1	P10EE	520664	1	xSet34	OFF	OFF	OFF	Low NOx conversion efficiency error
124	SCRMonDetMode-BLPlaus	P1703	520751	12	xSet34	OFF	OFF	OFF	DEF backflow line plausibility error
125	SCRMonDetMode-PresStab	P1702	520753	12	xSet34	OFF	OFF	OFF	DEF pressure stabilization error
126	SCRMonDetnModP-Drp	P1105	520752	12	xSet34	OFF	OFF	OFF	Abnormal DEF pressure drop error
127	SCRMonMetCtlOvr-PresErr	P20E9	520755	12	xSet34	OFF	OFF	OFF	Overpressure error during DEF dosing mode
128	SCRMonMetCtlUn-drPresErr	P20E8	520757	12	xSet34	OFF	OFF	OFF	Under pressure error during DEF dosing mode
129	SCRMonOvrPresErr	P1706	520758	12	xSet34	OFF	OFF	OFF	DEF over pressure error
130	SCRMonPresBuildUp-Err	P1106	520209	12	xSet34	OFF	OFF	OFF	Abnormal DEF pressure build-up error
131	SCRPODMonTnkT	P115C	3031	31	xSet16	OFF	OFF	OFF	Overheating error of DEF tank temperature
132	SMNoAvl	P1766	520632	31	xSet34	OFF	OFF	OFF	No information error for supply module temperature measurement
133	SMPerPwm	P1767	520632	0	xSet34	OFF	OFF	OFF	Invalid supply module PWM signal error
134	SMPwm	P1768	520632	2	xSet34	OFF	OFF	OFF	Supply module temperature PWM signal error
135	SRCHighAPP1	P0123	91	3	xSet35	OFF	OFF	OFF	High voltage error of accelerator pedal signal 1
136	SRCHighAPP2	P0223	29	3	xSet35	OFF	OFF	OFF	High voltage error of accelerator pedal signal 2
137	SRCLowAPP1	P0122	91	4	xSet35	OFF	OFF	OFF	Low voltage error of accelerator pedal signal 1
138	SRCLowAPP2	P0222	29	4	xSet35	OFF	OFF	OFF	Low voltage error of accelerator pedal signal 2
139	SRMinUPmpP	P204C	4334	4	xSet14	OFF	OFF	OFF	Low voltage error of DEF pump pressure sensor
140	SSpMon1	P0643	3511	7	xSet14	OFF	OFF	OFF	Collective error at sensor supply 1 (DEF pressure/fan speed sensor)
141	SSpMon1OT	P06B1	3511	12	xSet14	OFF	OFF	OFF	Over temperature error in ECU internal chip at sensor supply 1 (DEF pump pressure/fan speed sensor)
142	SSpMon1OV	P06B2	3511	0	xSet14	OFF	OFF	OFF	Over voltage error at sensor supply 1 (DEF pump pressure/fan speed sensor)
143	SSpMon1SCG	P06B4	3511	4	xSet14	OFF	OFF	OFF	Short circuit to ground error at sensor supply 1 (DEF pump pressure/fan speed sensor)
144	SSpMon1UV	P06B5	3511	1	xSet14	OFF	OFF	OFF	Under voltage error at sensor supply 1 (DEF pump pressure/fan speed sensor)
145	SSpMon2	P0653	3512	7	xSet18	OFF	OFF	OFF	Collective error for sensor supply 2 (SCR differential pressure/camshaft sensor)
146	SSpMon2OT	P06B3	3512	12	xSet18	OFF	OFF	OFF	Over temperature error in ECU internal chip at sensor supply 2 (SCR differential pressure/camshaft sensor)
147	SSpMon2OV	P16B5	3512	0	xSet18	OFF	OFF	OFF	Over voltage error at sensor Supply 2 (SCR differential pressure/camshaft sensor)
148	SSpMon2SCG	P1606	3512	4	xSet18	OFF	OFF	OFF	Short circuit to ground error at sensor Supply 2 (SCR differential pressure/camshaft sensor)
149	SSpMon2UV	P1610	3512	1	xSet18	OFF	OFF	OFF	Under voltage error at sensor supply 2 (SCR differential pressure/camshaft sensor)

No.	Fault	P-Code	SPN	FMI	EnvRef	Shut-down	Torque Limit	Speed Limit	Description
150	SSpMon3	P0699	3513	7	xSet4	OFF	OFF	OFF	Collective error at sensor supply 3 (throttle valve/rail pressure sensor)
151	SSpMon3OT	P1607	3513	12	xSet4	OFF	OFF	OFF	Over temperature Error in ECU internal chip at sensor supply 3 (throttle valve/rail pressure sensor)
152	SSpMon3OV	P16B2	3513	0	xSet4	OFF	OFF	OFF	Over voltage error at sensor supply 3 (throttle valve/rail pressure sensor)
153	SSpMon3SCG	P1608	35	4	xSet4	OFF	OFF	OFF	Short circuit to ground error at sensor supply 3 (throttle valve/rail pressure sensor)
154	SSpMon3UV	P16B1	3514	18	xSet4	OFF	OFF	OFF	Under voltage error at sensor supply 3 (throttle valve/rail pressure sensor)
155	SSpMon4	P16B3	3514	12	xSet2	OFF	OFF	OFF	Collective error at sensor supply 4 (boost pressure/oil pressure/VGT speed sensor)
156	SSpMon4OT	P1609	3514	7	xSet2	OFF	OFF	OFF	Over temperature error in ECU internal chip at sensor supply 4 (boost pressure/oil pressure/VGT speed sensor)
157	SSpMon4OV	P16B4	3514	0	xSet2	OFF	OFF	OFF	Over voltage error at sensor supply 4 (boost pressure/oil pressure/VGT speed sensor)
158	SSpMon4SCG	P1700	3514	4	xSet2	OFF	OFF	OFF	Short circuit to ground error at sensor supply 4 (boost pressure/oil pressure/VGT speed sensor)
159	SSpMon4UV	P1701	3514	1	xSet2	OFF	OFF	OFF	Under voltage error at sensor supply 4 (boost pressure/oil pressure/VGT speed sensor)
160	StrtHSSCB	P1617	520522	3	xSet1	OFF	OFF	OFF	Short circuit to battery error at starter high side powerstage
161	StrtHSSCG	P1616	520522	4	xSet1	OFF	OFF	OFF	Short circuit to ground error at starter high side powerstage
162	StrtLSOL	P0615	520523	5	xSet1	OFF	OFF	OFF	Open load error at starter low side powerstage
163	StrtLSOvrTemp	P0618	520523	12	xSet1	OFF	OFF	OFF	Over temperature error in ECU internal chip at starter low side powerstage
164	StrtLSSCB	P0617	520523	3	xSet1	OFF	OFF	OFF	Short circuit to battery error at starter low side powerstage
165	StrtLSSCG	P0616	520523	4	xSet1	OFF	OFF	OFF	Short circuit to ground error at starter low side powerstage
166	SyncAPP	P2135	91	12	xSet35	OFF	OFF	OFF	Synchronization error for pedal signals
167	TCACDsPhysRngHi	P0110	105	0	xSet10	OFF	OFF	OFF	High boost temperature error
168	TCACDsSRCMax	P0113	105	3	xSet10	OFF	OFF	OFF	High voltage error for boost temperature sensor
169	TCACDsSRCMin	P0112	105	4	xSet10	OFF	OFF	OFF	Low voltage error for boost temperature sensor
170	TECUPhysRngHi_0	P0669	1207	0	xSet2	OFF	OFF	OFF	High ECU internal temperature error [1]
171	TECUPhysRngHi_1	P166A	1208	0	xSet2	OFF	OFF	OFF	High ECU internal temperature error [2]
172	TECUPhysRngLo_0	P0668	1207	1	xSet2	OFF	OFF	OFF	Low ECU internal temperature error [1]
173	TECUPhysRngLo_1	P166B	1208	1	xSet2	OFF	OFF	OFF	Low ECU internal temperature error [2]
174	TECUSigRngMax	P1670	1208	2	xSet2	OFF	OFF	OFF	Short circuit to battery or CRC error for ECU temperature sensor
175	TECUSigRngMin	P1671	1208	3	xSet2	OFF	OFF	OFF	Short circuit to ground or CRC error for ECU temperature sensor
176	TECUSnsrPlaus	P1672	1208	12	xSet2	OFF	OFF	OFF	Plausibility error for internal ECU temperature sensor
177	TECUSRCMax	P1669	1207	3	xSet2	OFF	OFF	OFF	High voltage error for ECU temperature sensor
178	TECUSRCMin	P1668	1207	4	xSet2	OFF	OFF	OFF	Low voltage error for ECU temperature sensor
179	TOxiCatUsPhysRngHi	P2080	4765	0	xSet19	OFF	50% ↓	200rpm ↓	High Turbocharger downstream temperature error
180	TOxiCatUsSRCMax	P0546	4765	3	xSet19	OFF	OFF	OFF	High voltage error for Turbocharger downstream temperature
181	TOxiCatUsSRCMin	P0545	4765	4	xSet19	OFF	OFF	OFF	Low voltage error for Turbocharger downstream temperature
182	UCatDsTPhysRngHi	P043B	4363	0	xSet22	OFF	50% ↓	200rpm ↓	High SCR downstream temperature error
183	UCatDsTSRCMax	P043D	4363	3	xSet22	OFF	OFF	OFF	High voltage error for SCR downstream temperature sensor

No.	Fault	P-Code	SPN	FMI	EnvRef	Shut-down	Torque Limit	Speed Limit	Description
184	UCatDsTSRCMin	P043C	4363	4	xSet22	OFF	OFF	OFF	Low voltage error for SCR downstream temperature sensor
185	UCatUsTPhysRngHi	P0436	4360	0	xSet21	OFF	50% ↓	200rpm ↓	High SCR upstream temperature error
186	UCatUsTSRCMax	P0438	4360	3	xSet21	OFF	OFF	OFF	High voltage error for SCR upstream temperature
187	UCatUsTSRCMin	P0437	4360	4	xSet21	OFF	OFF	OFF	Low voltage error for SCR upstream temperature
188	UDCRdcAgRmn	P103C	1761	7	xSet15	OFF	OFF	OFF	Low DEF tank level error
189	UDosVlvOL	P1739	520828	5	xSet34	OFF	OFF	OFF	Open circuit error for dosing valve actuator
190	UDosVlvSCB	P1718	520765	3	xSet34	OFF	OFF	OFF	Short circuit to battery error for DEF dosing valve actuator
191	UDosVlvSCG	P1716	520765	4	xSet34	OFF	OFF	OFF	Short circuit to ground error for DEF dosing valve actuator
192	UDosVlvSCHSLS	P1717	520766	4	xSet34	OFF	OFF	OFF	Short circuit to ground error for DEF dosing valve high side
193	UHCEnfShOffWiEmp	P1730	520822	12	xSet34	OFF	OFF	OFF	DEF pressure line heater error (Perform after-run)
194	UHtrBLOL	P20B9	4354	5	xSet25	OFF	OFF	OFF	Open circuit error for DEF backflow line heater
195	UHtrBLSCB	P20BC	4354	3	xSet25	OFF	OFF	OFF	Short circuit to battery error for DEF backflow line heater
196	UHtrBLSCG	P20BB	4354	4	xSet25	OFF	OFF	OFF	Short circuit to ground error for DEF backflow line heater
197	UHtrPLOL	P20BD	4355	5	xSet25	OFF	OFF	OFF	Open circuit error for DEF pressure line heater
198	UHtrPLSCB	P20C0	4355	3	xSet25	OFF	OFF	OFF	Short circuit to battery error for DEF pressure line heater
199	UHtrPLSCG	P20BF	4355	4	xSet25	OFF	OFF	OFF	Short circuit to ground error for DEF pressure line heater
200	UHtrRlyOL	P202A	4358	5	xSet25	OFF	OFF	OFF	Open circuit error for DEF tank heating relay
201	UHtrRlySCB	P202C	4358	3	xSet25	OFF	OFF	OFF	Short circuit to battery error for DEF tank heating relay
202	UHtrRlySCG	P202B	4358	4	xSet25	OFF	OFF	OFF	Short circuit to ground error for DEF tank heating relay
203	UHtrSLOL	P20C1	4356	5	xSet25	OFF	OFF	OFF	Open circuit error for DEF suction line heater
204	UHtrSLSCB	P20C4	4356	3.0	xSet25	OFF	OFF	OFF	Short circuit to battery error for DEF suction line heater
205	UHtrSLSCG	P20C3	4356	4	xSet25	OFF	OFF	OFF	Short circuit to ground error for DEF suction line heater
206	UHtrSMOL	P20C5	4357	5	xSet25	OFF	OFF	OFF	Open circuit error for DEF supply module heater
207	UHtrSMSCB	P20C8	4357	3	xSet25	OFF	OFF	OFF	Short circuit to battery error for DEF supply module heater
208	UHtrSMSCG	P20C7	4357	4	xSet25	OFF	OFF	OFF	Short circuit to ground error for DEF supply module heater
209	UHtrTnkOL	P20B1	3363	5	xSet25	OFF	OFF	OFF	Open circuit error for coolant valve
210	UHtrTnkSCB	P20B4	3363	3	xSet25	OFF	OFF	OFF	Short circuit to battery error for coolant valve
211	UHtrTnkSCG	P20B3	3363	4	xSet25	OFF	OFF	OFF	Short circuit to ground error for coolant valve
212	UPmpMotNoAvl	P1723	520771	12	xSet36	OFF	OFF	OFF	DEF pump motor no activation error
213	UPmpMotOL	P208A	520772	5	xSet36	OFF	OFF	OFF	Open circuit error for DEF pump motor
214	UPmpMotSCB	P208D	520772	3	xSet14	OFF	OFF	OFF	Short circuit to battery error for DEF pump motor
215	UPmpMotSCG	P208C	520772	4	xSet14	OFF	OFF	OFF	Short circuit to ground error for DEF pump motor
216	UQISensPhyRngHi	P206D	3516	0	xSet17	OFF	OFF	OFF	High DEF quality error
217	UQISensPhyRngLo	P206C	520811	1	xSet17	OFF	OFF	OFF	Low DEF quality error
218	URRevVlvOL	P20A0	4376	5	xSet34	OFF	OFF	OFF	Open circuit error for DEF reverting valve
219	URRevVlvSCB	P20A3	4376	3	xSet34	OFF	OFF	OFF	Short circuit to battery error for DEF reverting valve
220	URRevVlvSCG	P20A2	4376	4	xSet34	OFF	OFF	OFF	Short circuit to ground error for DEF reverting valve

9. Aftertreatment System (IMO Tier3/Stage-V)

9.1. Exhaust Gas Reduction System

9.1.1. Selective Catalytic Reduction (SCR)

- Selective catalytic reduction (SCR) is a device which injects DEF (Diesel Exhaust Fluid, urea) into the exhaust gas produced by the engine and causes a catalytic reaction with the nitrogen oxide in the exhaust gas, thereby converting it into harmless nitrogen (N₂) and water vapor (H₂O).

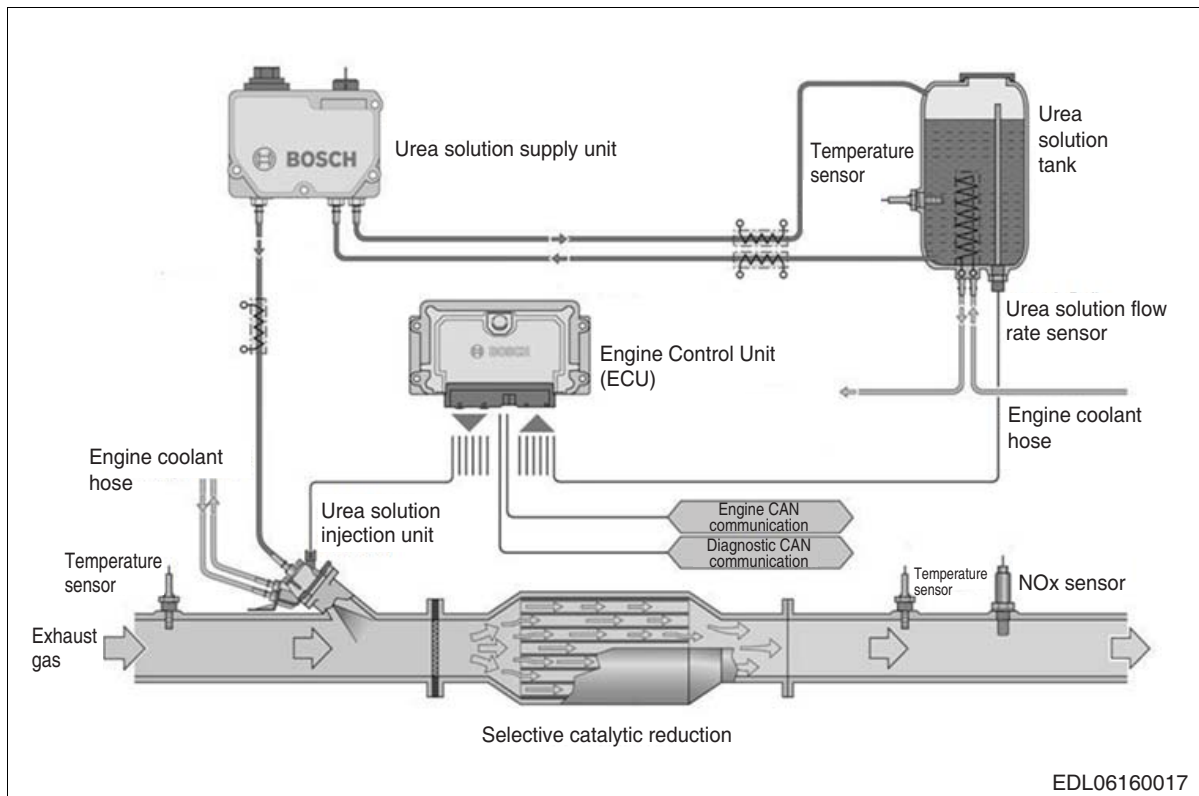

- DEF (Diesel Exhaust Fluid, Urea)

1) DEF (Diesel Exhaust Fluid, urea) is not a toxic material, but a fluid in which clean water and urea are mixed together.

(Urea : 32.5%, water : 67.5%)

2) In selective catalytic reduction, the following chemical reaction takes place, thereby converting nitrogen oxide (NO_x) into nitrogen (N₂) and water vapor.

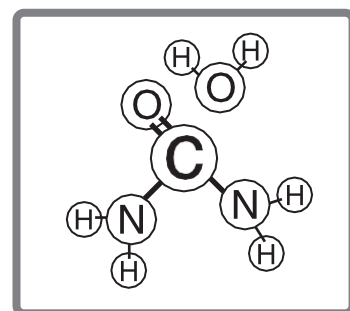
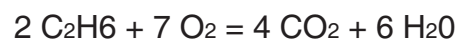

EDL06160022

9.1.2. Aftertreatment Muffler and Catalyst

The aftertreatment muffler consists of a removable SCR (Selective Catalytic Reduction) unit and an inlet/outlet; the SCR catalyst has a sensor bracket for mounting related sensors.

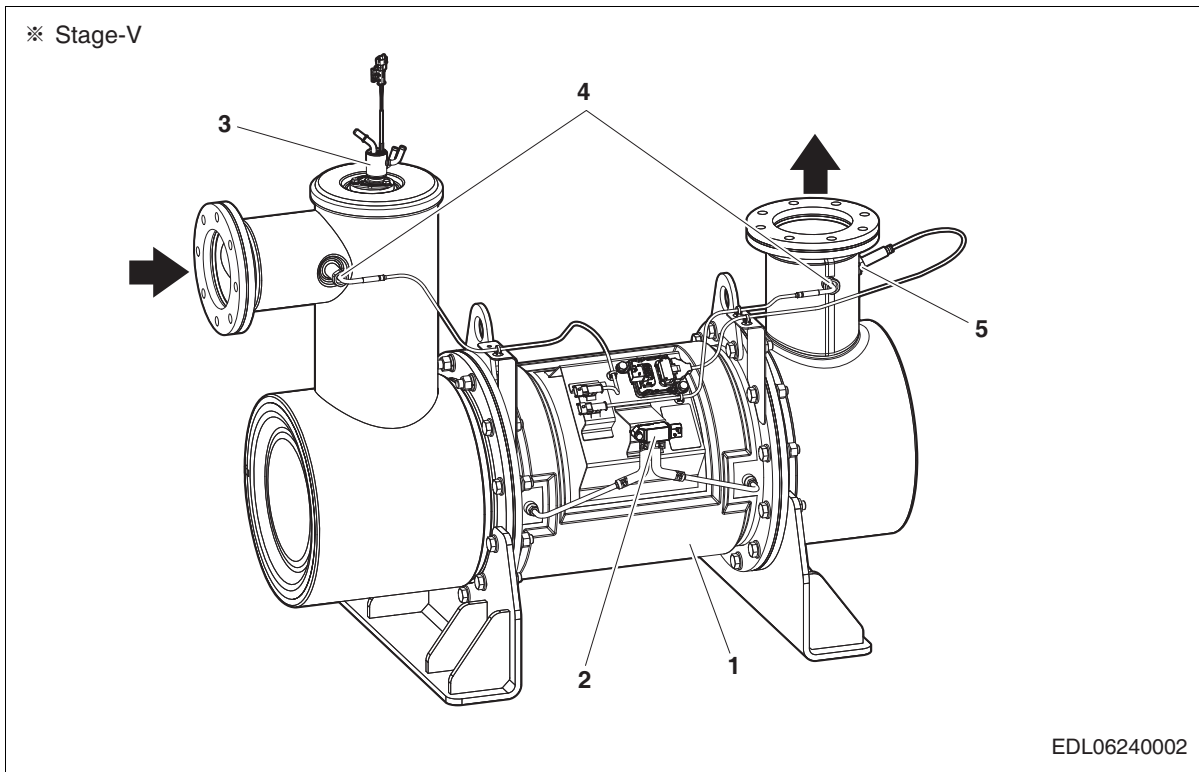
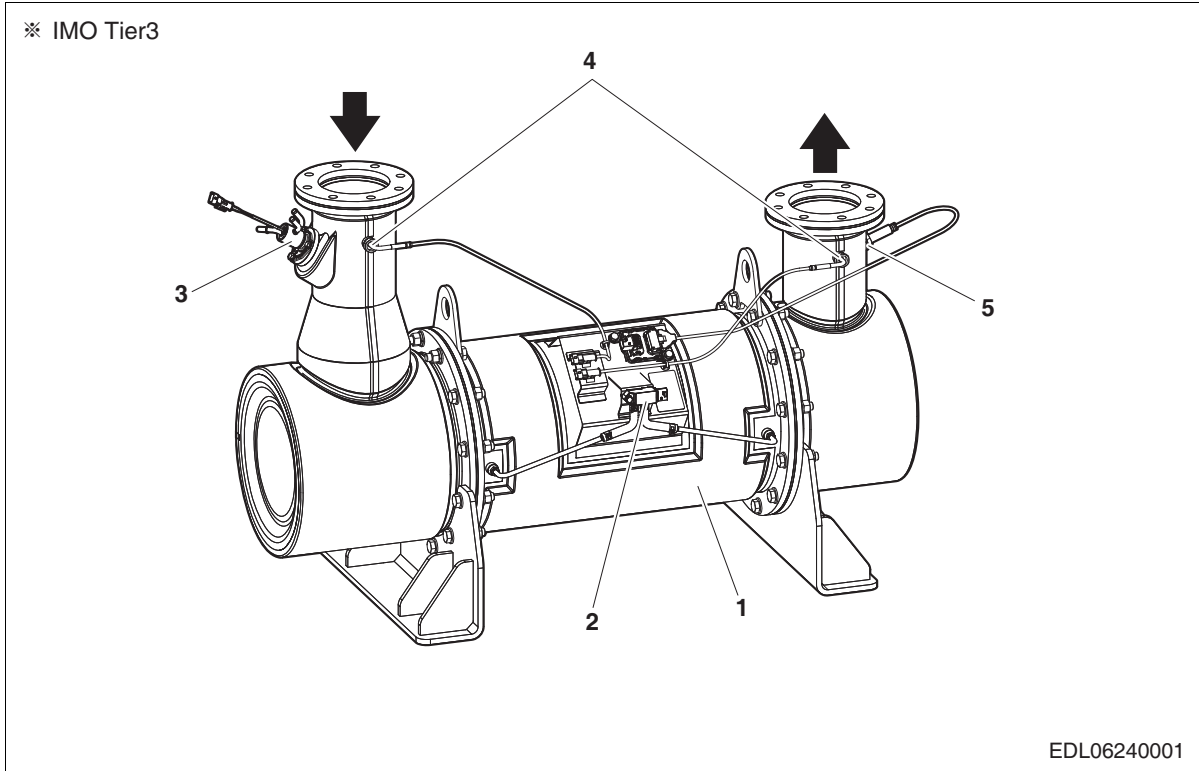

- 1. SCR catalyst
- 2. DP sensor

- 3. Dosing module
- 4. Temperature sensor

- 5. NOx sensor



CAUTION:

As an important part necessary for satisfying emissions regulations, the SCR catalyst requires regular yearly maintenance; if a problem occurs, the relevant measures must be taken and the SCR catalyst must be replaced.

Monitoring of SCR reducing agent slip or SCR efficiency degradation is checked through the NOx sensor, and "P10EE" occurs when an error occurs, and SCR ATS inspection is required when the error occurs.

Internal damage and blockage monitoring of SCR is monitored through DP sensor, and "P1456" and "P1457" occur when an error occurs, and SCR ATS inspection is required when the error occurs.

9.1.3. DNOX 2.2 EVO System

The DNOX 2.2 EVO system injects DEF (Diesel Exhaust Fluid, urea) into the SCR catalyst to reduce NOx (nitrogen oxide) emissions. The system consists of a supply module acting as a pump, a dosing module which injects DEF, an ECU which controls the entire system, a DEF tank for storing DEF, and DEF/coolant lines.

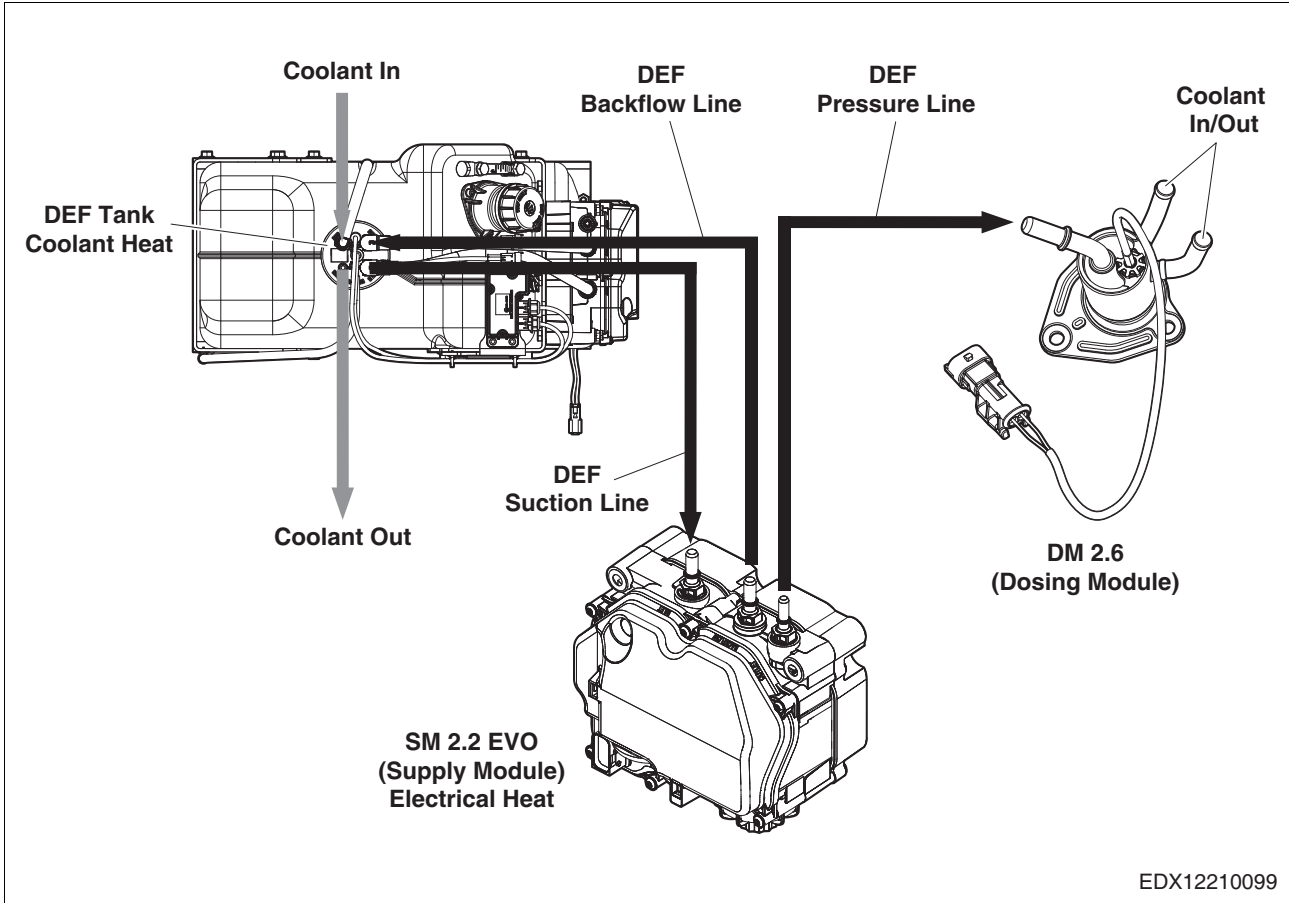

CAUTION:

DEF (Urea) should not exceed the "F" line of the level indicator attached to the DEF TANK.

(Reference for models that HD Hyundai Infracore supplies DEF TANK.)

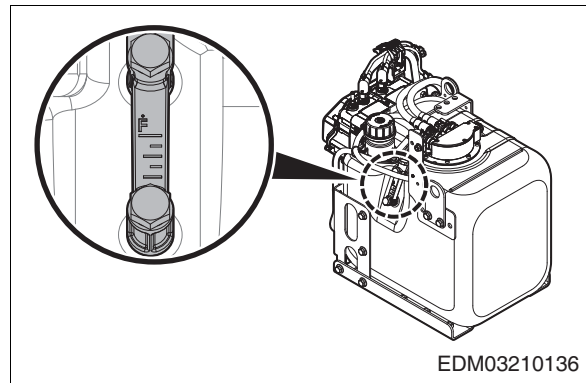

The images shown represent the standard model; they do not include all models.

9.1.4. DEF Tank

The DEF tank is used to store DEF (Diesel Exhaust Fluid, Urea). Be sure to install connecting lines in their designated positions. Take care not to apply any excessive force or shocks to the DEF tank during maintenance.

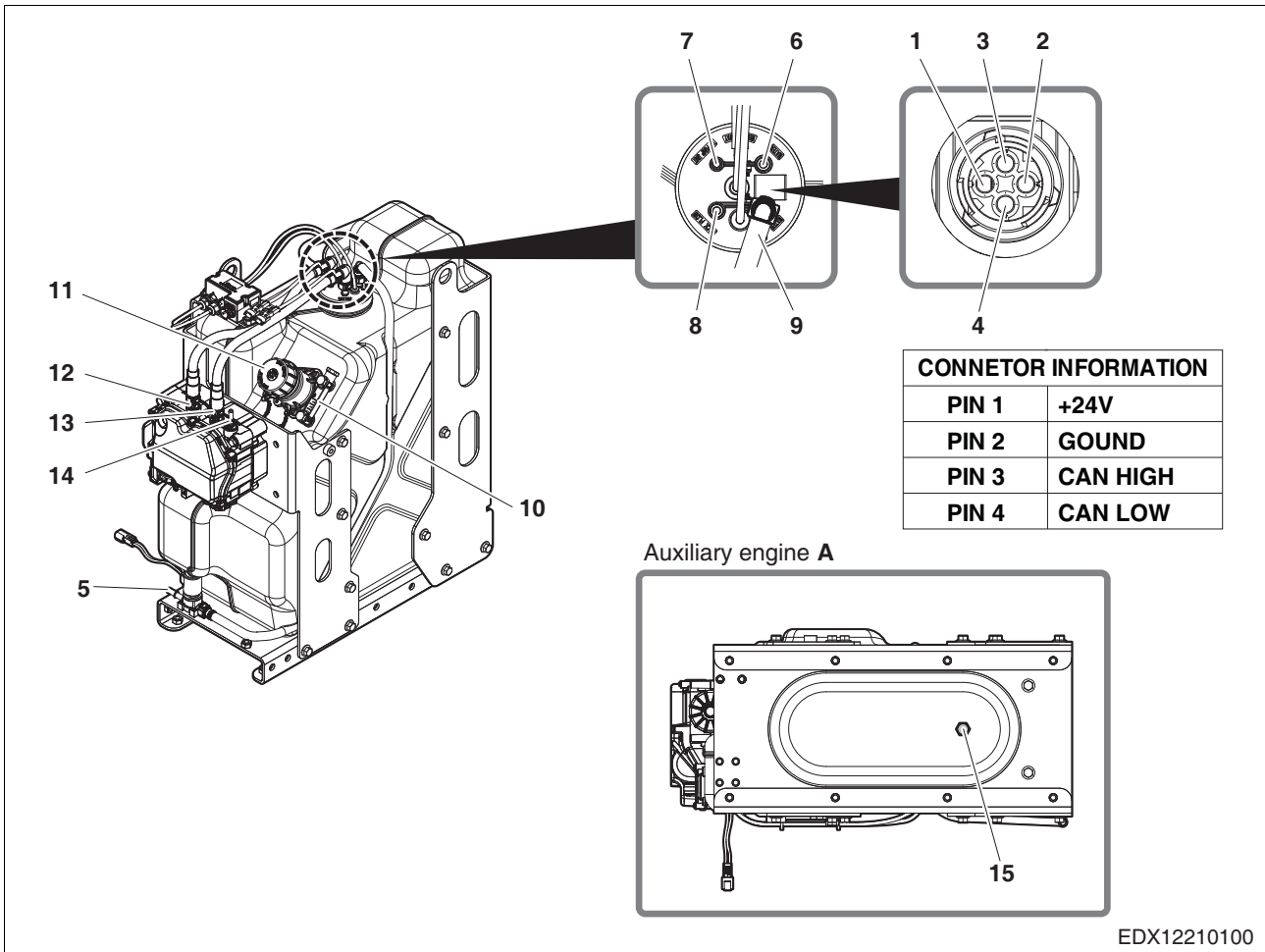

- | | | |
|------------------------|---------------------|--------------------------------|
| 1. +24V (Pin No.1) | 6. Coolant outlet | 11. DEF tank cap |
| 2. Ground (Pin No.2) | 7. DEF outlet | 12. DEF intake (from the tank) |
| 3. CAN HIGH (Pin No.3) | 8. DEF inlet | 13. DEF return line |
| 4. CAN LOW (Pin No.4) | 9. Coolant inlet | 14. DEF pressurized outlet |
| 5. Coolant inlet | 10. Level indicator | 15. Drain plug |

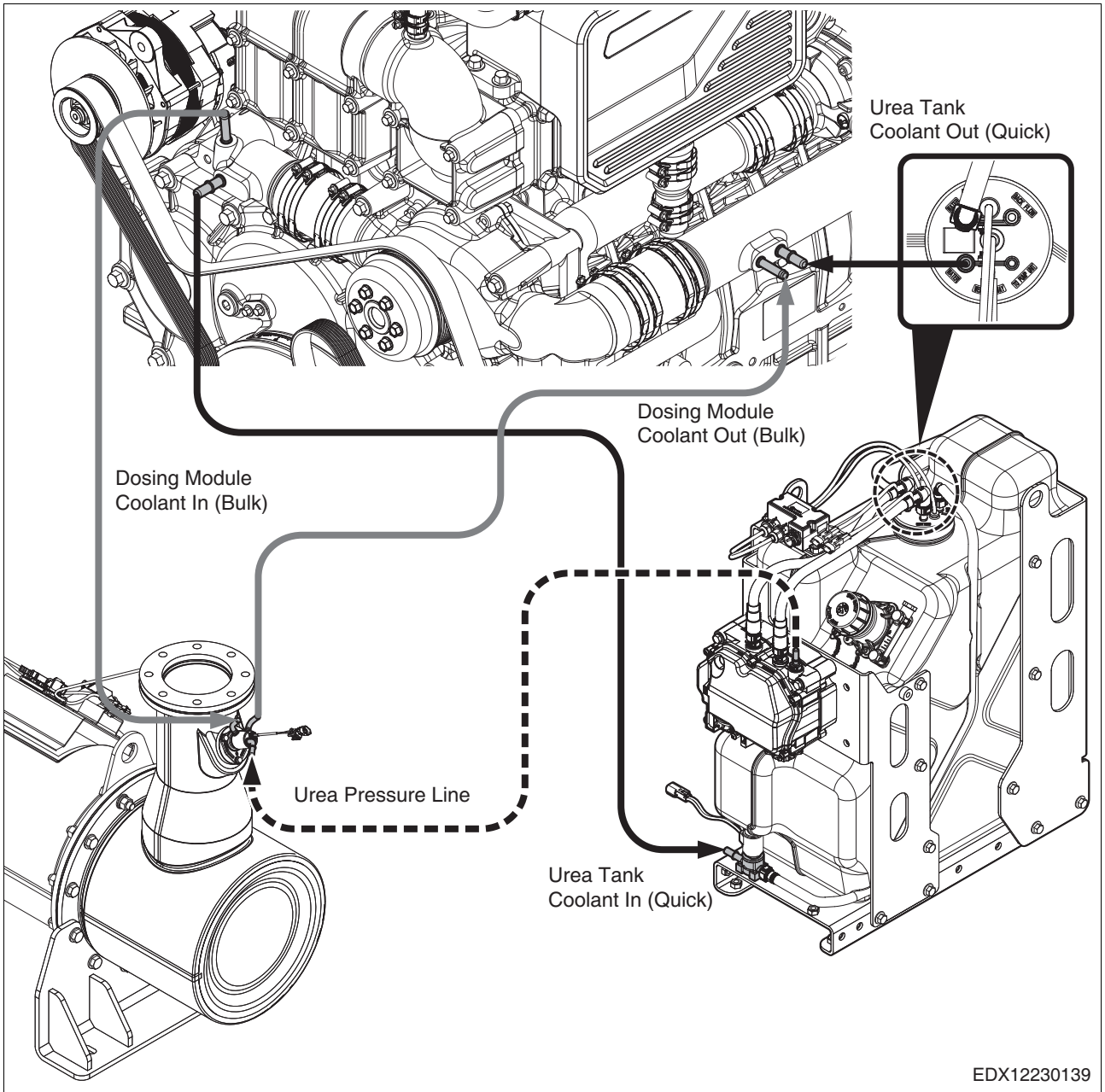

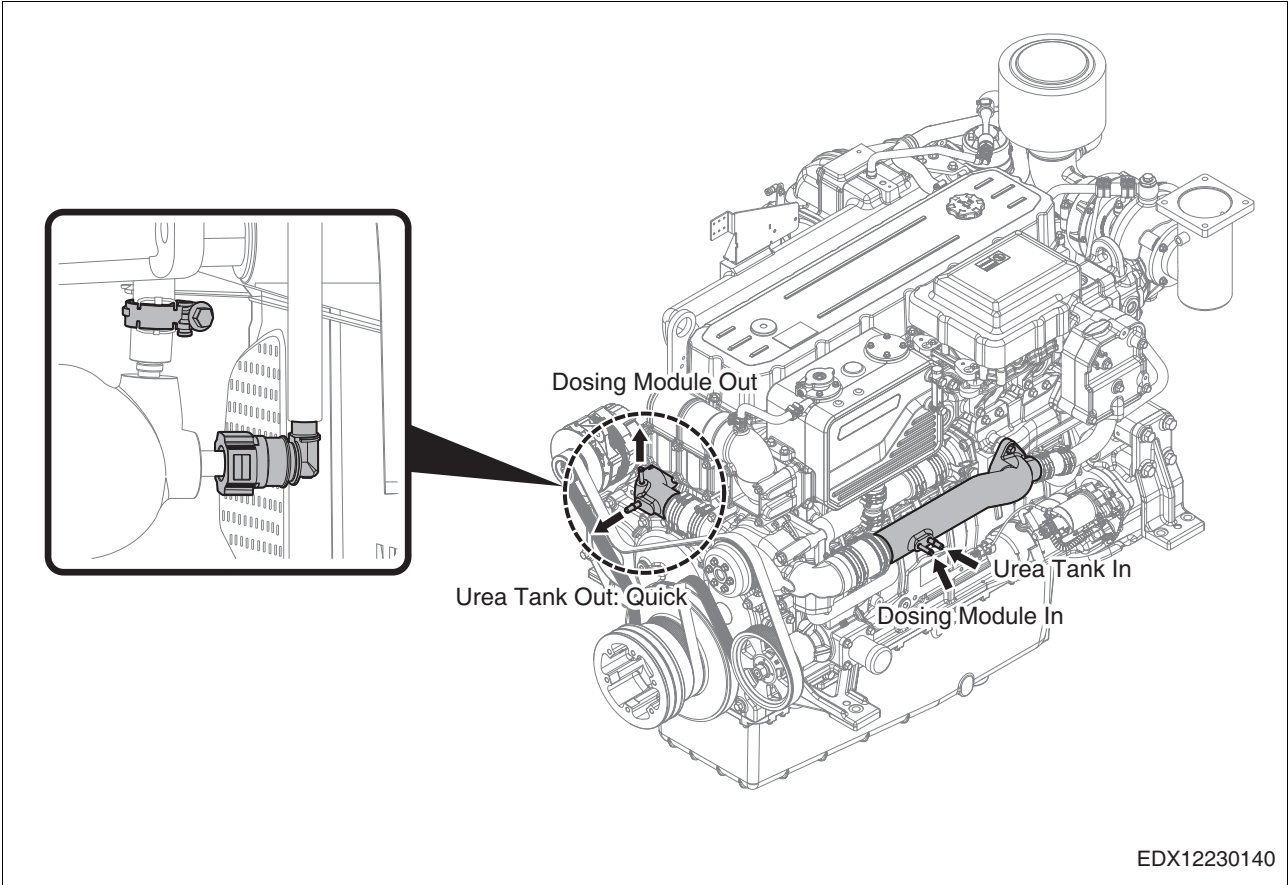

EDX12230140

9.1.5 DEF (Diesel Exhaust Fluid, Urea) pre-heater (heating of the urea solution)

- DEF (Diesel Exhaust Fluid, urea) is frozen at or below $-11\text{ }^{\circ}\text{C}$, and therefore, the DEF tank should be heated with the engine coolant.

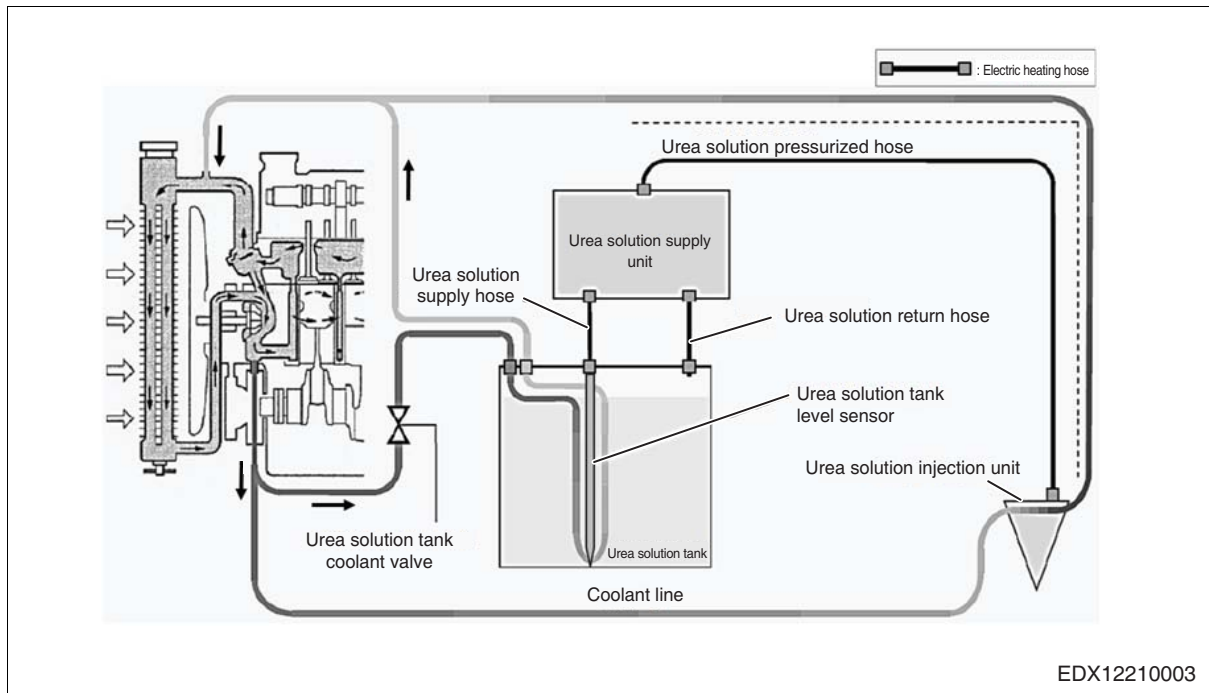

9.1.6. Supply Module

The supply module is a device which pressurizes DEF in the DEF tank to a constant pressure and delivers it to the dosing module.

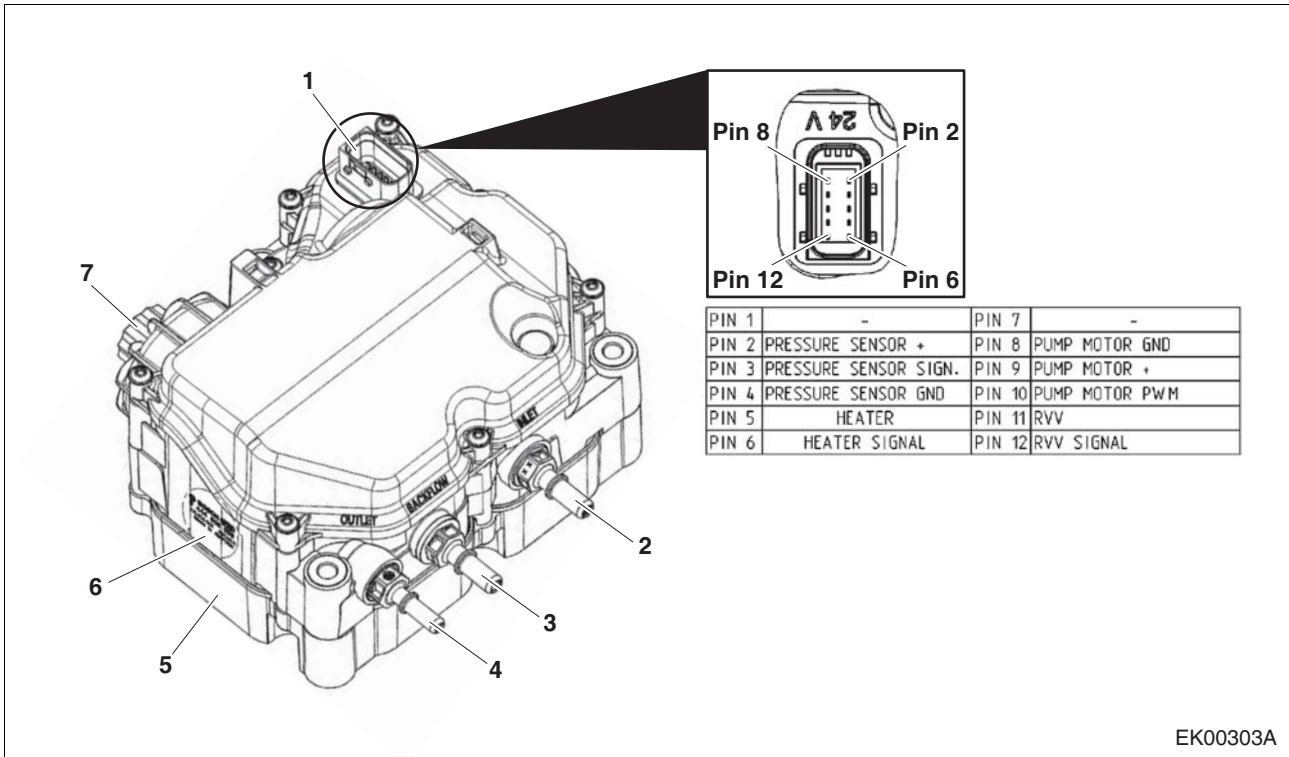

- | | |
|----------------------|---------------------|
| 1. Connector | 5. Cover plate |
| 2. DEF inlet | 6. Detailed display |
| 3. DEF return outlet | 7. Filter cover |
| 4. DEF outlet | |

9.1.7. Dosing Module

The dosing module injects the pressurized DEF from the supply module into the exhaust gas.

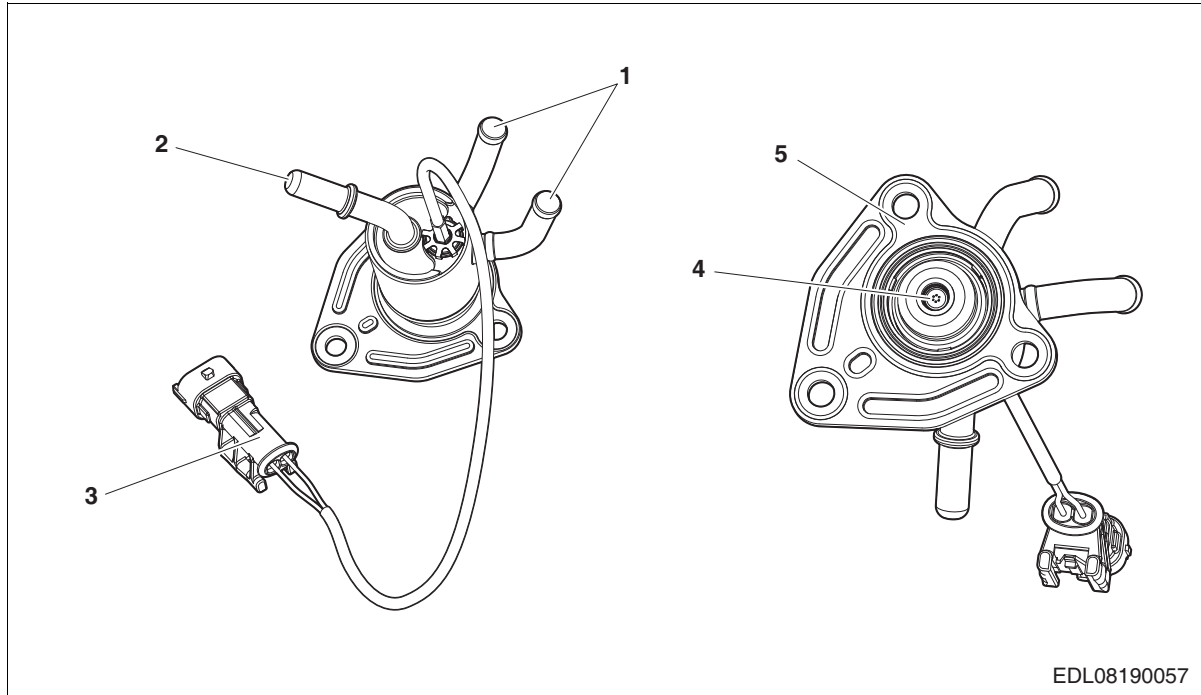

1. Coolant inlet/outlet

2. DEF inlet

3. Connector

4. DEF injection nozzle

5. Flange

9.1.8. Replacing the DEF Filter

1) Remove the filter cover.

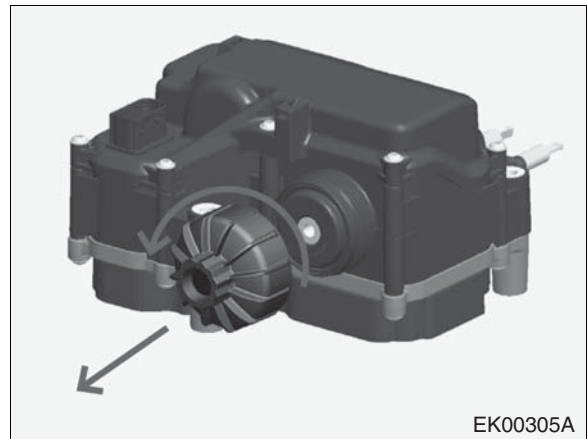

2) Remove the equalizing element.

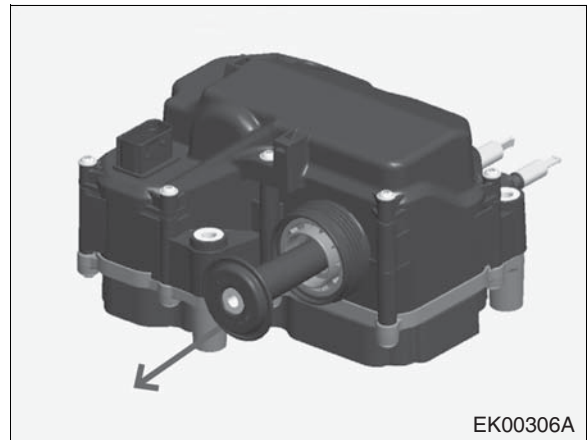

3) Check the color of the inside of the filter (gray/green).

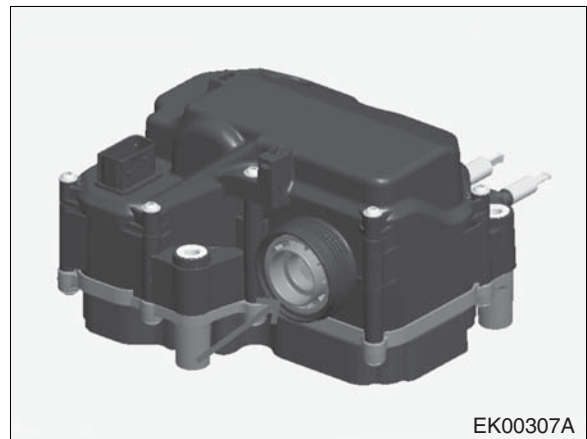

4) Adjust the filter removal tool so that the color on the end of the tool faces the same direction as the color of the filter.

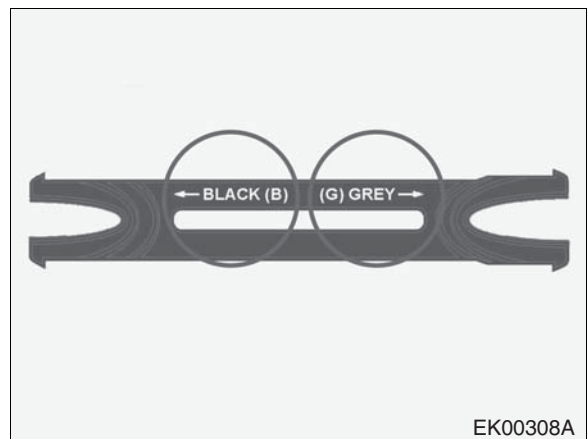

- 5) Insert the end of the filter removal tool into the filter until a click is heard or until it grips the filter.

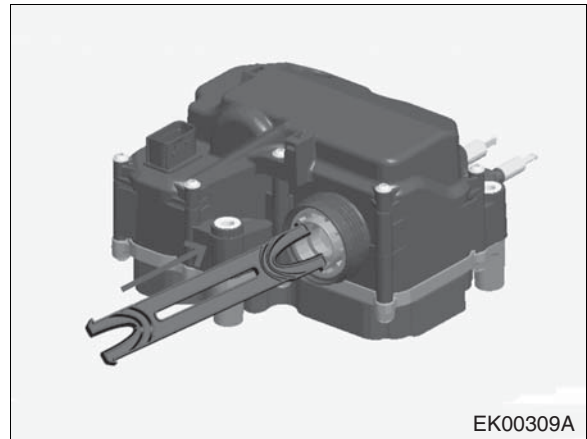

- 6) Pull on the filter removal tool to remove the filter.

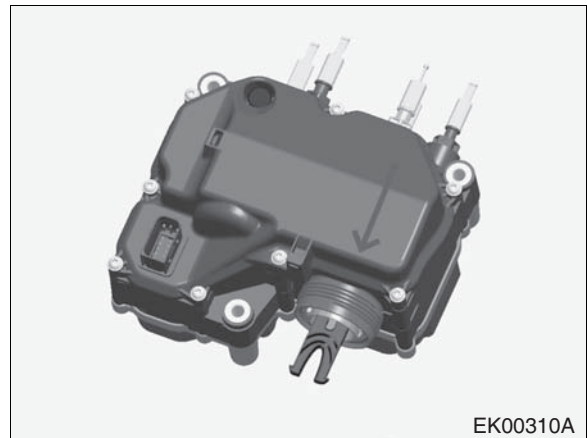

- 7) Keep the surface clean and wash the surface with water only.

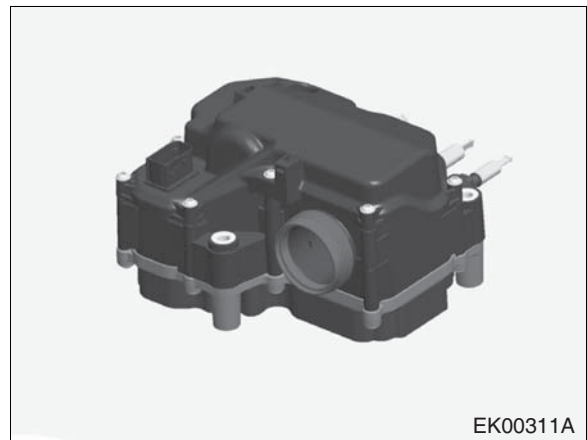

- 8) Apply oil to an O-ring and install a new filter.



CAUTION:
Use the Mobil Velocite No.6 oil sold by Bosch.

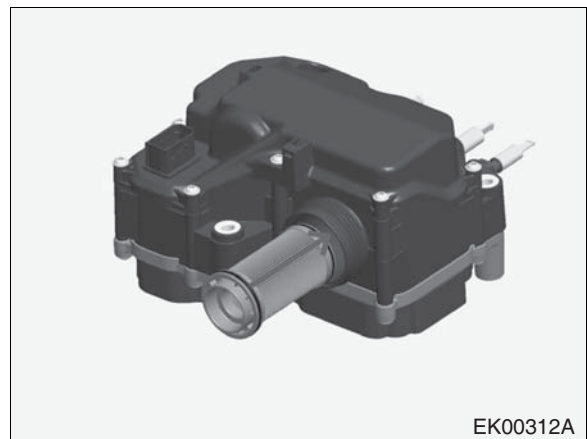

9) Install a new equalizing element.

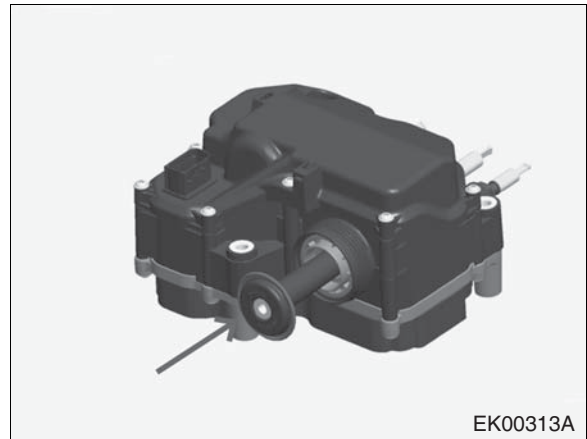

10) Tighten the filter cover to a tightening torque of 20 +5 N·m.



CAUTION:

Check whether the surface of the filter cover is clean. The surface can only be washed with water.

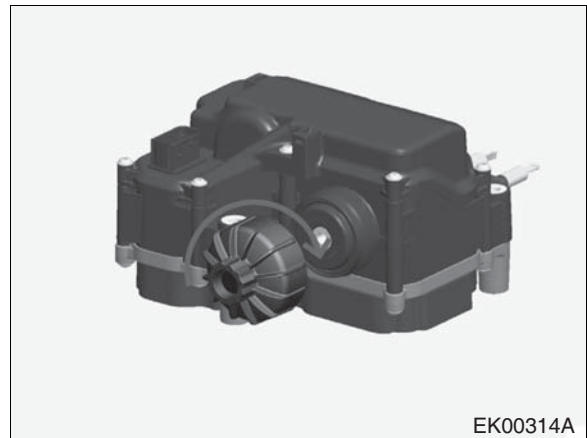

9.1.9. Components of the DNOX 2.2 EVO System

1) The components of the DNOX 2.2 EVO are installed throughout the ship where they are most essential. Each part is designed to be protected from damage due to the surroundings.



CAUTION:

The supply module is mounted on the DEF tank.

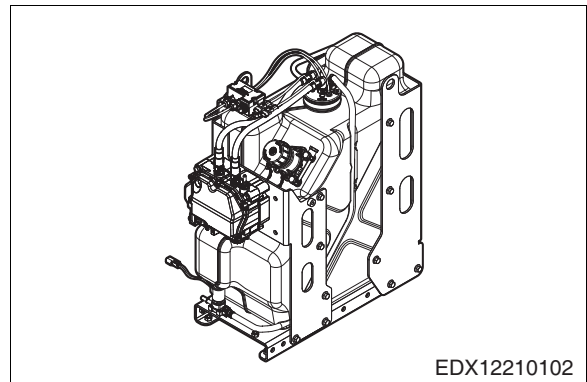

9.1.10. Inspecting the DNOX 2.2 EVO System for Faults

1) Dosing Module

Dosing module faults can be caused by exposure of the DEF injection nozzle tip to high temperatures, poor contact in the electric harness, and damage or poor contact in DEF hose lines, etc. The following DM faults can be inspected visually.

- a) Air leak due to insufficiently tightened bolt or DM (Dosing Module) and bolt damaged due to overtightened bolt during replacement or installation of the DM.
- b) Improperly installed electrical connector or connector contaminated by foreign matter.
- c) DEF leak due to improperly connected DEF line.
- d) Coolant leak due to improperly connected coolant line or DM exposed to high temperatures due to disconnected coolant line.
- e) DM exposed to high temperatures due to improperly installed gasket.
- f) DEF leak due to reuse of gasket.

2) Supply Module

Supply module (SM) fault modes may be caused by damaged or improperly connected DEF lines and electrical connectors. Faults may occur due to incorrect installation during regular replacements of the main urea filter.



CAUTION:

When replacing a filter, remove the packaging on the new filter immediately before performing the replacement.

- a) Fault due to improper assembly or improperly connected line while connecting DEF lines.
- b) Improperly installed electrical connector or connector contaminated by foreign matter.
- c) Filter damaged due to use of improper tools during replacement of SM filter or residue build-up in SM filter.
- d) Cap damaged by overtightening of DEF cap during filter replacement or filter loose due to incorrect installation.

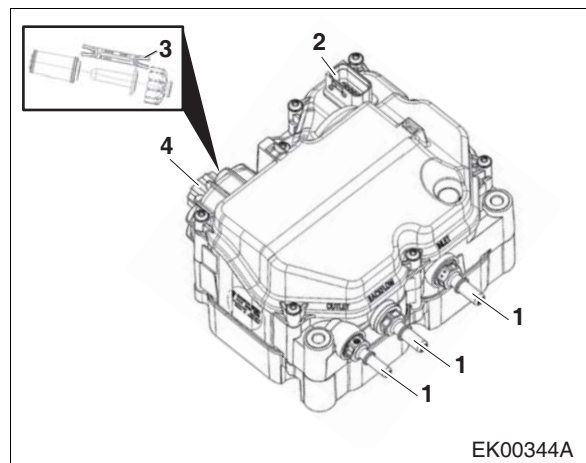
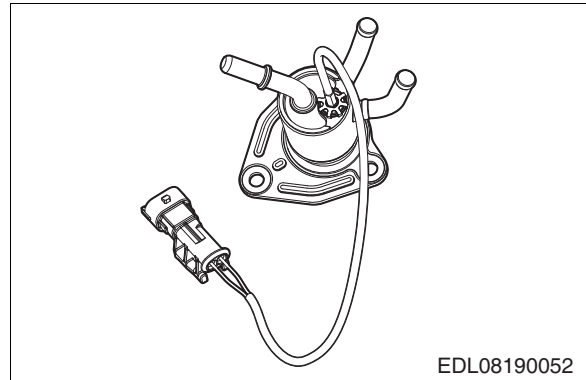

3) DEF Tank

The DEF tank is used to store DEF (Diesel Exhaust Fluid, Urea).

Be sure to install connecting lines in their designated positions. Take care not to apply any excessive force or shocks to the DEF tank during maintenance.

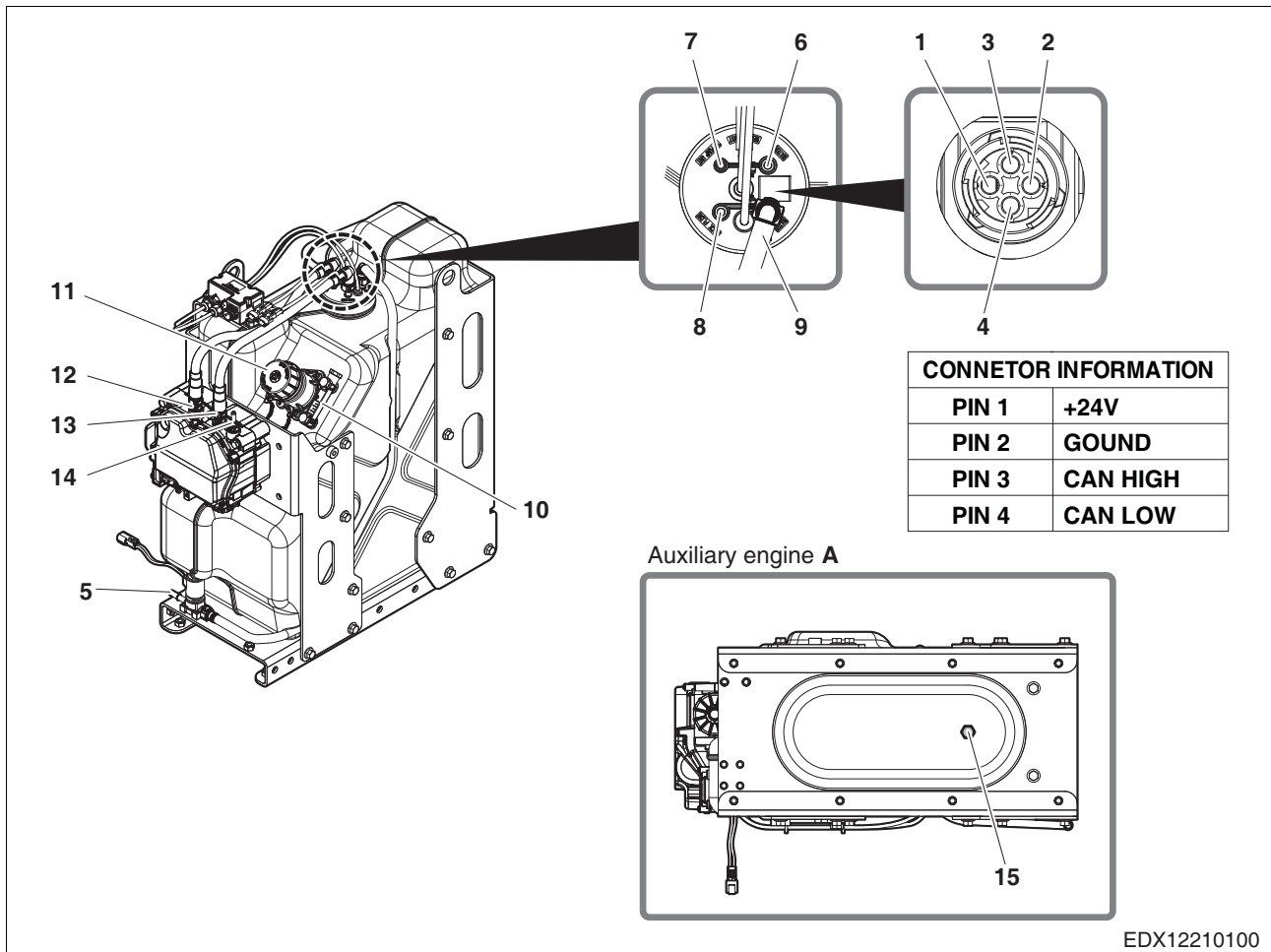

CAUTION:

Although a DEF inlet hose and backflow hose are already installed prior to release from the factory, take care not to mix them up during removal and reassembly.



CAUTION:

- Check whether the DEF tank mounting bracket has been tightened. Failing to tighten it may lead to damage due to vibrations.
- Check the tank temperature and the connection of the level sensor connector, taking care to avoid damaging or contaminating the connector with foreign matter.
- Coolant lines must be installed in their proper positions. Failing to tighten coolant lines may cause coolant leakage.
- Check the connection of the DEF line heater (2-PIN). There is a risk of freezing and bursting in winter if the heater is not working.

4) Muffler and other pipes

The preassembled muffler and various pipes do not need to be replaced, removed, or relocated unless there is a fault or problem due to external influences.

If replacement or removal is necessary due to a fault or problem, make sure to tighten each part to its specified tightening torque in order to prevent leaks.

9.1.11. DEF (Diesel Exhaust Fluid, Urea)

Component	Unit	Range		Test Method
		Minimum	max	
Urea concentration ^a	% (m/m) ^b	31.8	33.2	ISO 22241-2 Annex B ^c ISO 22241-2 Annex C ^c
Density (at 20°C ^d)	kg/m ³	-	1,093	ISO 3675 or ISO 12185
Deflection (at 20°C ^e)	-	-	1.3843	ISO 22241 2 Annex C
Ammonia alkaline	% (m/m) ^b	-	0.2	ISO 22241 2 Annex D
Biuret	% (m/m) ^b	-	0.3	ISO 22241 2 Annex E
Aldehydes	mg/kg	-	5	ISO 22241 2 Annex F
Insoluble matter	mg/kg	-	20	ISO 22241 2 Annex G
Phosphate (PO ₄)	mg/kg	-	0.5	ISO 22241 2 Annex H
Calcium	mg/kg	-	0.5	ISO 22241 2 Annex I
Iron	mg/kg	-	0.5	
Copper	mg/kg	-	0.2	
Zinc	mg/kg	-	0.2	
Chrome	mg/kg	-	0.2	
Nickel	mg/kg	-	0.2	
Aluminum	mg/kg	-	0.5	
Magnesium	mg/kg	-	0.5	
Sodium	mg/kg	-	0.5	
Potassium	mg/kg	-	0.5	
Identity	-	Identical		

a) Reference value: 32.5% (m/m).

b) The unit "%(m/m)" is used to express the mass of matter as a fraction according to international standards.

c) Calculated without subtracting nitrogen from ammonia.

d) Reference value: 1,090 kg/m³

e) Reference value: 1.3829

DEF requires the addition of a tracer element. Take care to ensure that the quality of AUS 32 indicated in the table and the tracer element do not damage the SCR system.



CAUTION:

The conditions of ISO 4259 must be applied between the maximum and minimum values within the specified range. Be sure to take the minimum difference of 4 x R (R is the reproducibility of the test method) into account. However, for the sake of maintaining high quality, 4 x R is not factored into the urea concentration.



CAUTION:

The urea concentration, density and deflection are the actual values. (For the actual values, please refer to ISO 4259)



CAUTION:

The values defined in notes a, d and e are standard among DEF manufacturers.



CAUTION:

Be sure to check whether the DEF (Diesel Exhaust Fluid, urea) satisfies the required specifications. Be sure to apply the conditions of ISO 4259.

9.1.12. Disassembling the SCR Catalyst

- 1) Disconnect dosing module (A) coolant hose and DEF hose.



CAUTION:

Take care not to spill hot coolant or DEF during removal.

- 2) Remove temperature sensor and NOx sensor (B).
- 3) Unscrew flange bolts (C) and disassemble the SCR catalyst.



CAUTION:

Gaskets and clamps are intended for single use only; do not reuse them.

- 4) Perform reassembly in the reverse order of disassembly, tightening parts to their specified tightening torque.

Name	Tightening Torque
NOx sensor	50 ±5 Nm
Temperature sensor	45 ±5 Nm
M6 bolt (DP sensor & dosing module)	8 ±2 Nm
M14 bolt	98 – 117 Nm

A temperature sensor is installed in the SCR muffler inlet and outlet to measure the temperature of the aftertreatment system's SCR catalyst.

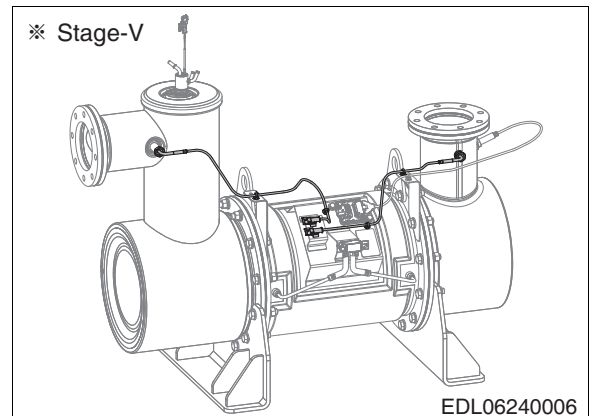
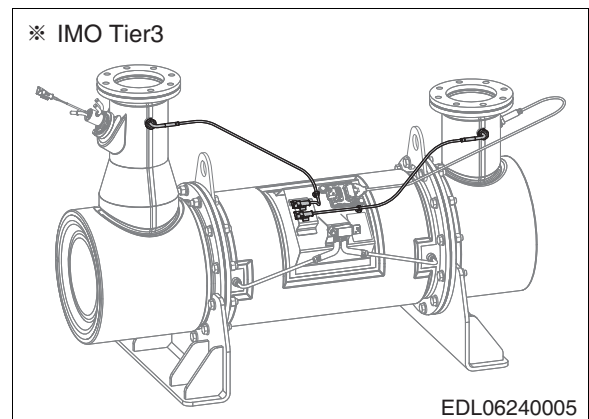
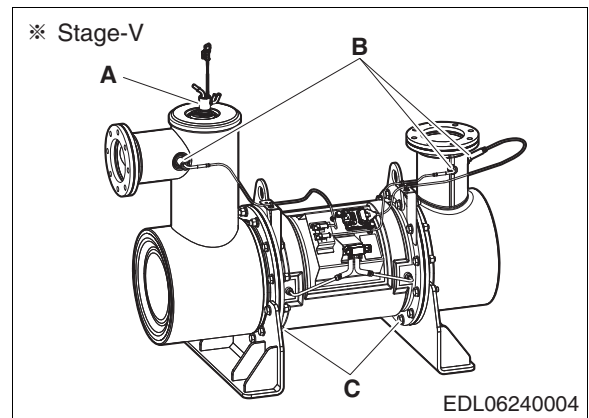
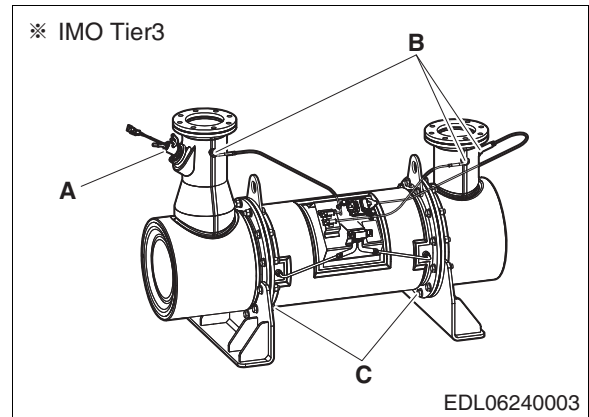

- The SCR catalyst temperature sensor measures the temperature for DEF injection and serves to detect abnormal exhaust gas temperatures; the ECU monitors this data and warns the operator. In the event of a fault, suitable measures must be taken in accordance with the user's manual.

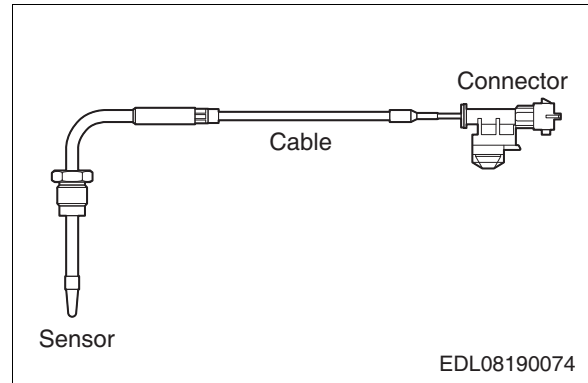

- A differential pressure sensor is installed to measure the pressure difference upstream and downstream of the SCR catalyst and check for clogging in the SCR catalyst.

Connector Pin No.	Pin Name
1	Supply voltage (VCC)
2	Ground
3	Output signal

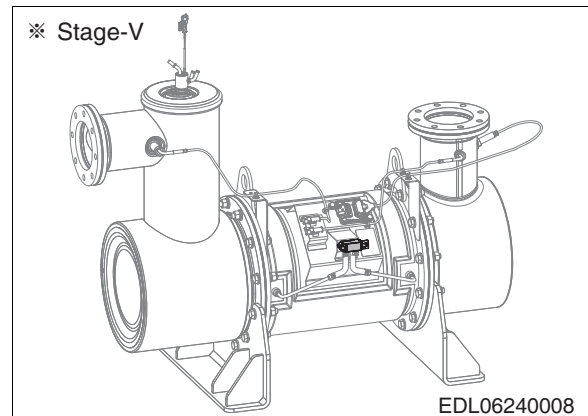
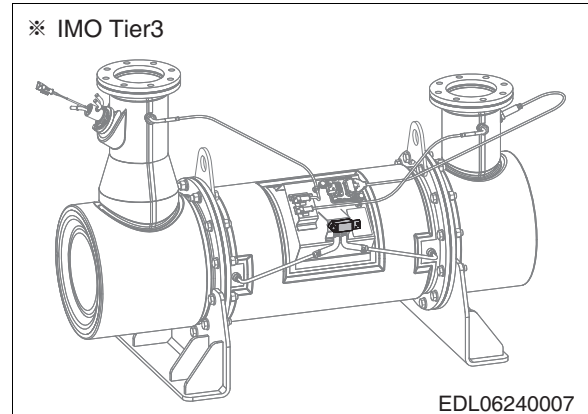

- The differential pressure sensor measures for clogging in the SCR catalyst; when abnormal differential pressure occurs, the ECU detects this and warns the operator. In the event of a fault, suitable measures must be taken in accordance with the user's manual.

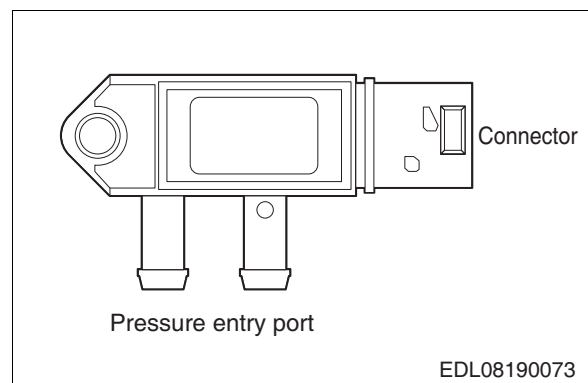

CAUTION

Due to high-sulfur fuel for ships, catalyst clogging can occur, and in case of excessive differential pressure, operation at maximum power for over one hour is recommended.

In case of continuous faults after that, appropriate measures should be taken according to the User Manual.

- The NOx sensor mounted downstream of the SCR muffler measures the amount of nitrogen oxide (NOx); if the NOx value increases relative to the reference value, the operator is warned. In the event of a fault, suitable measures must be taken in accordance with the user's manual.



CAUTION

In case of faults because of the degraded catalyst efficiency with the use of high-sulfur fuel for ships, operation at maximum power for over one hour is recommended. In case of continuous faults after that, appropriate measures should be taken according to the User Manual.

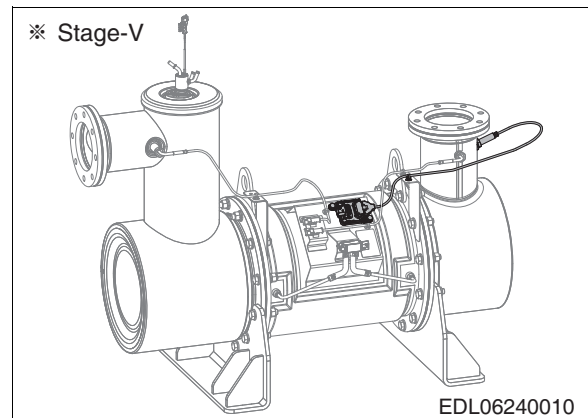
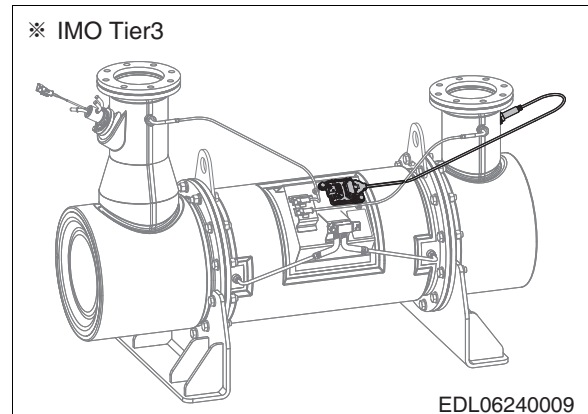

9.1.13. Cautions for Handling the SCR Muffler

- 1) The muffler weighs around 102 kg, and the SCR catalyst is sensitive to impacts, so be careful.
- 2) When replacing the differential pressure sensor, take care to ensure that foreign matter does not enter the differential pressure sensor pipe. If foreign matter enters the pipe, a fault may occur due to a misreading of the differential pressure.
- 3) After removing the SCR assembly, take care to prevent foreign matter from entering the inlet/outlet. If foreign matter enters the system, the SCR catalyst may be damaged.
- 4) Be careful not to damage the differential pressure sensor and temperature sensor during removal and installation.
- 5) Reusing gaskets removed during the removal of the SCR catalyst may cause leaks, so make sure to use new gaskets.
- 6) Air leaks in the exhaust system can lead to violation of emissions regulations, increased noise, and increased exhaust smoke, so be sure to tighten parts to their specified tightening torque.

Appendix

● Main Tightening Torques

<Chart of Specified Tightening Torques>

Main Components	Screw (dia. X pitch)	Strength (class)	Tightening Torque
Cylinder head bolt	M16 × 1.5	10.9T	6 kg·m + 90° + 90° + 30°
Connecting rod bearing cap bolt	M16 × 1.5	12.9T	8 kg·m + 60° (0° ~ 10°)
Crankshaft main bearing cap bolt	M16 × 1.5	12.9T	30.0 kg·m
Balance weight mounting bolt	M14 × 1.5	10.9T	9.0 kg·m
Flywheel mounting bolt	M14 × 1.5	10.9T	18.0 kg·m
Crankshaft mounting bolt	M14 × 1.5	12.9T	22 kg·m

<Tightening Torque for Injection Pump System>

Components	Tightening Torque
HPC nut	Temporary tightening: 0.3 ±0.1 kg·m
	Final torque: 5.3 ±0.3 kg·m
High-pressure fuel pipe	4.0 ±0.4 kg·m

<Standard Bolt Tightening Torque by Specification>

Refer to the following table for bolts not mentioned in previous chapters.

Unit : mm

Dia. x pitch (mm)	Strength class										
	3.6 (4A)	4.6 (4D)	4.8 (4S)	5.6 (5D)	5.8 (5S)	6.6 (6D)	6.8 (6S)	6.9 (6G)	8.8 (8G)	10.9 (10K)	12.9 (12K)
M5 x Std.	0.15	0.16	0.25	0.22	0.31	0.28	0.43	0.48	0.50	0.75	0.90
M6 x Std.	0.28	0.30	0.45	0.40	0.55	0.47	0.77	0.85	0.90	1.25	1.50
M7 x Std.	0.43	0.46	0.70	0.63	0.83	0.78	1.20	1.30	1.40	1.95	2.35
M8 x Std.	0.70	0.75	1.10	1.00	1.40	1.25	1.90	2.10	2.20	3.10	3.80
M8 x 1	0.73	0.80	1.20	1.00	1.50	1.35	2.10	2.30	2.40	3.35	4.10
M10 x Std.	1.35	1.40	2.20	1.90	2.70	2.35	3.70	4.20	4.40	6.20	7.20
M10 x 1.25	1.50	1.60	2.50	2.10	3.10	2.80	4.30	4.90	5.00	7.00	8.40
M12 x Std.	2.40	2.50	3.70	3.30	4.70	4.20	6.30	7.20	7.50	10.50	12.50
M12 x 1.25	2.55	2.70	4.00	3.50	5.00	4.50	6.80	7.70	8.00	11.20	13.40
M14 x Std.	3.70	3.90	6.00	5.20	7.50	7.00	10.00	11.50	12.00	17.00	20.00
M14 x 1.5	4.10	4.30	6.60	5.70	8.30	7.50	11.10	12.50	13.00	18.50	22.00
M16 x Std.	5.60	6.00	9.00	8.00	11.50	10.50	15.50	17.90	18.50	26.00	31.00
M16 x 1.5	6.20	6.50	9.70	8.60	12.50	11.30	17.00	19.50	20.00	28.00	35.50
M18 x Std.	7.80	8.30	12.50	11.00	16.00	14.50	21.00	27.50	28.50	41.00	43.00
M18 x 1.5	9.10	9.50	14.40	12.50	18.50	16.70	24.50	27.50	28.50	41.00	49.00
M20 x Std.	11.50	12.00	18.00	16.00	22.00	19.00	31.50	35.00	36.00	51.00	60.00
M20 x 1.5	12.80	13.50	20.50	18.00	25.00	22.50	35.00	39.50	41.00	58.00	68.00
M22 x Std.	15.50	16.00	24.50	21.00	30.00	26.00	42.00	46.00	49.00	67.00	75.00
M22 x 1.5	17.00	18.50	28.00	24.00	34.00	29.00	47.00	52.00	56.00	75.00	85.00
M24 x Std.	20.50	21.50	33.00	27.00	40.00	34.00	55.00	58.00	63.00	82.00	92.00
M24 x 2.0	23.00	35.00	37.00	31.00	45.00	38.00	61.00	67.00	74.00	93.00	103.00

Notes :

1. The torque classes specified above are based on a 70% bolt elastic limit.
2. The tensile force is the tensile strength multiplied by the cross-sectional area of the screw.
3. Special screws should be tightened to only 85% of the standard value. For example, MoS2-coated screws should be tightened to 60% of the standard value.

● Specification Chart for Maintenance of Main Components

Unit : mm

Item	Component	Check Items	Assembly standard	Usable Limit	Repairs	Remarks	
Engine body	Cylinder block and liner	Worn inside diameter of cylinder liner	Ø123 ~ Ø123.025	Ø123.223	Replace cylinder liner.	Measure non-worn part under upper rim	
		Liner protrusion	0.03 ~ 0.08		There must be protrusion	0.15 ↓ difference in protrusion with nearby liner	
		Flatness of warped upper surface of cylinder block	0.05		Correct with surface grinder Modified	For length of 200 mm	
		Hydrostatic test (one minute) (kg/cm ²)	4		Replace if leaking oil		
	Cylinder head and valve	Valve seat depression	0 ~ 0.3	0.55	-	Replace the valve seat	
			0 ~ 0.3	0.55	-		
		Cylinder head height	154.7 ~ 155.3	153.7	Replace cylinder head		
	Hydrostatic test (one minute) (kg/cm ²)	4		Replace if leaking oil	Water temperature: 70 °C		
Major drive components	Pistons	Piston O.D.	Ø122.854 - Ø122.886		Replace the liner	Measure at a point 13 mm from the bottom surface of the piston	
		Clearance between piston and liner	0.123 ~ 0.162		Replace if wear exceeds the specification		
		Piston ring groove width	3.5			Replace the piston if the groove width exceeds the specified amount	
			3.060 ~ 3.080				
			4.040 ~ 4.060				
		Piston protrusion from upper surface of cylinder block	0 ~ 0.12				Measure under non-worn edge of top part
	Allowable weight difference among pistons	±15 g	96 g ↓	Replace piston			
	Piston ring	Piston ring gap	Top ring	0.30 ~ 0.45	0.7	Replace ring	Standard gauge I.D. : Ø123
			Second ring	1.0 ~ 1.2	1.45		
			Oil ring	0.30 ~ 0.50	0.7		
		Piston ring side gap	Top ring			Replace ring or piston Replace	Usable limit for standard gap Usable Limit
			Second ring	0.07 ~ 0.102	Ø0.125		
			Oil ring	0.05 ~ 0.085	Ø0.11		
		Direction of ring clearance			Install rings at 120° intervals from one another		

Item	Component	Check Items	Assembly standard	Usable Limit	Repairs	Remarks
Major drive components	Crankshaft	Unevenly worn journal and pin	0.05	0.1	Repair with grinder	Measure in vertical and horizontal directions
		Journal O.D.	Ø95.966 ~ Ø95.988	Ø94.966	Replace crankshaft	Ø96g6
		Pin O.D.	Ø85.966 ~ Ø85.988	Ø84.966	Replace crankshaft	Ø86g6
		Ovalness of journal and pin	0.008	0.025		
		Allowable concentricity of journal and pin	0.01	0.03		
		Allowable inclination of journal and pin	0.01	0.03		
		Crankshaft and bearing clearance	0.072 ~ 0.142	0.25	Replace the bearing	Measure on crown
		Crankshaft free play	0.1 ~ 0.3	0.5	Thrust bearing Replace	
		Deflection of crankshaft	0.1	0.15 or less	Correct deflection with a press	Measure at no. 4 (Supporting No. 1 and 7)
		Crankshaft balance (g.cm)	60	60 or less	Check dynamic balancing	Measure at 400 rpm
		Journal bearing cap bolt tightening torque (kg.m)	30		Apply oil to bolt	There should be no foreign material on the bearing cap mounting surface
		Journal bearing crush	0.16 ~ 0.24			Tighten the metal cap and unscrew one stud bolt for measurement
	Worn oil seal (Back side of crankshaft)			Replace oil seal if there are any oil leaks	Replace with new part, Use a shim	
	Connecting rods	Connecting rod free play	0.22 ~ 0.319	0.50	Replace connecting rod	
		Clearance between connecting rod bearing and crankpin	0.049 ~ 0.119	0.20	Replace the bearing	
		Clearance between small end bushing and piston pin	0.050 ~ 0.080	0.12		Unscrew one bolt and measure after installing bearing
		Height of connecting rod bearing crush	0.17 ~ 0.25			Unscrew one stud bolt and measure after tightening bearing cap
		Allowable weight difference among connecting rods	±18 g			
		Connecting rod bearing cap bolt torque (kg.m)	8 kg.m + 60° (0° ~ 10°)		Do not apply oil to the bolt	
	Camshaft	Camshaft O.D.	Ø59.86 ~ Ø59.88	Ø59.56		Ø60
		Clearance between camshaft and bushing	0.045 ~ 0.100	0.20		
		Camshaft axial play	0.14 ~ 0.25	0.50	Replace thrust plate	

Item	Component	Check Items	Assembly standard	Usable limit	Repairs	Remarks		
Major drive components	Timing gear	Clearance between idler gear shaft and insertion hole	0.048 ~ 0.096	0.19				
		End play of idler gear shaft	0.107 ~ 0.203	0.25	Replace thrust collar			
		Clearance between crank gear and oil pump idler gear	0.060 ~ 0.184	0.26	Replace gear			
		Between oil pump idler gear and oil pump gear	0.020 ~ 0.292	0.41				
		Crank gear and idler gear A	0.062 ~ 0.194	0.27				
		Between idler gear B and camshaft gear	0.090 ~ 0.236	0.33				
		Clearance between idler gear and high-pressure fuel pump idler gear	0.072 ~ 0.189					
		Clearance between high-pressure fuel pump idler gears A and B	0.071 ~ 0.191	0.33				
Valve system	Valves	Intake valve stem O.D.	Ø7.963 ~ Ø7.977	Ø7.943	Replace valve and guide	When replacing the valve, replace the valve guide as well		
		Exhaust valve stem O.D.	Ø7.950 ~ Ø7.964	Ø7.920				
		Clearance between valve stem and valve guide	Intake	0.023 ~ 0.052	0.10	Replace valve and guide		
			Exhaust	0.036 ~ 0.065	0.15	Replace		
		Valve thickness	Intake	3.3 ~ 3.7	2.8	Replace		
			Exhaust	4.0 ~ 4.4	3.5			
		Clearance between valve guide and cylinder head mounting hole		0.01 ~ 0.039			Apply oil to valve guide	
		Allowable radial runout between valve stem and valve head	Intake	0.04 ~ 0.07	0.2	Replace		
			Exhaust	0.06 ~ 0.09	0.25			
		Intake spring	Exterior	Free length	62.5	-	Replace the valve spring	
				Spring tension (P1/P2) kg	44.0 31.6	37.4 ~ 41.4 63.3 ~ 68.3		
				Straightness (compared to free length)	1.6	2.0		
		Exhaust spring	Exterior	Free length	62.5	-	Replace the valve spring	
				Spring tension (P1/P2) kg	44.0 31.6	37.4 ~ 41.4 63.3 ~ 68.3		
Straightness (compared to free length)	1.6			2.0				

Item	Component	Check Items	Assembly standard	Usable Limit	Repairs	Remarks
Valve system	Tappet	Clearance between rocker arm shaft and rocker arm bushing	0.015 ~ 0.059	0.12	Replace the bushing or shaft	
		Rocker arm shaft wear	Ø24.953 ~ Ø24.976	Ø24.916	Replace	
		Allowable pushrod taper	0.3		Replace	
		Clearance between tappet and cylinder block	0.035 ~ 0.077	0.15	Replace tappet	
		Tappet O.D.	Ø19.944 ~ Ø19.965		Replace tappet	
		Contact surface of tappet and cam	-	-	Replace if excessively deformed or worn	
Lubrication system	Oil pressure	Oil pressure (normal speed) kg/cm ²	4.5 or less	3.5	Oil leak Check clearance and angle	
		Oil pressure (no load) kg/cm ²	0.8 ~ 1.4	0.6	Use recommended oil	
	Oil temperature	Max. allowable oil temp. °C	-	105		No temperatures higher than this are allowed
		Instant allowable oil temp. °C	-	120		
	Valve opening pressure	Oil pressure adjustment valve (kg/cm ²)	4.0 ~ 5.0	-	Replace valve	
		Bypass valve for oil filter element (kg/cm ²)	1.8 ~ 2.4			
		Oil pump relief valve (kg/cm ²)	9.5 ~ 12.5			
		Spray nozzle adjustment valve (kg/cm ²)	1.9 ~ 2.1			
	Oil filter	Damaged oil filter cartridge			Clean and replace	

Item	Component	Check Items	Assembly standard	Usable Limit	Repairs	Remarks
Cooling system	Coolant pump	Displacement l/min - Engine rpm : 1,800 rpm - Water temp. : 80 °C - Negative pressure : 0.5 kg/cm ²	Approx. 270		Repair or replace	
		Clearance between pump impeller and housing body	0.5 ~ 0.9		Replace if impeller and housing are touching one another	
	Coolant Temperature	Operating temperature (suitable temperature) °C	94 ~ 98	98		No temperatures higher than this are allowed
		Instant allowable temp. °C	105	105		
	Thermostat	Thermostat opening temperature °C (at atmospheric pressure)	79		Replace	
		Fully open temperature of thermostat °C	94 or less		Replace if defective	Lift : Min. 8 mm
Fuel system	Piping, etc. Misc.	Damaged or cracked fuel pipe, injection pipe or nozzle holder; defective packing			Repair or replace	
		Damaged fuel filter cartridge			Replace cartridge	
	Height of nozzle protrusion from cylinder head surface (mm)	2.53		Replace cylinder head and nozzle		

Digital Panel

for Electronic Controlled Marine Engines

User Manual

Ver.1.1



HYUNDAI

► Contents

1. General Information	
1.1 Product Information	3
1.2 Components	3
1.3 Product Specification	4
2. Product Installation	
2.1 Cautions	5
2.2 Desk Mounting Type	6
2.3 Flush Mounting Type	7
3. Part Names, Operation and Settings	
3.1 Front Side	8
3.2 Back Side	8
3.3 External Connection Terminals	9
3.3.1 Main Connector	9
3.3.2 CAN Communication Connector	10
3.3.3 External Buzzer Connector	10
3.3.4 USB Connector	10
3.4 Fuse and Internal Buzzer	11
3.4.1 Fuse	11
3.4.2 Internal Buzzer	11
3.5 Key Switch	11
3.6 Start Button	12
3.7 Emergency Stop Button	12
3.8 Function Keys	13
3.8.1 Detailed Settings	14
3.9 Display Structure	15
3.9.1 Engine Speed (Tachometer)	15
3.9.2 Engine Water Temperature	16
3.9.3 Engine Oil Pressure	16
3.9.4 Exhaust Gas Temperature	16
3.9.5 Gearbox Oil Pressure	17
3.9.6 Battery Voltage	17
3.9.7 Sensor Check Lamp	17
3.9.8 Engine Alarm	18
3.9.9 Engine Stop	18
3.10 Sensor etc.	19

► Contents

3.11	Fault Code Inform.	-----	20
3.12	Event Summary	-----	21
3.13	System Booting and Functional Check	-----	22
4.	Multi Panel Structure		
4.1	Multi Panels	-----	23
4.2	How to Install Multi Panels	-----	24
4.3	Multi Panel Settings	-----	25
5.	Maintenance		
5.1	Maintenance	-----	26
5.2	Troubleshooting	-----	26
6.	Warranty and A/S Service		
6.1	Warranty	-----	27
6.2	A/S Service Information	-----	27



1. General Information

1.1 Product Information

The name of the product model is a digital panel applicable to electronic engine type ships and other various marine e-engines. The product is intended to improve problems of existing analog panels and allow users to check engine controls and conditions by means of a digital visualization product. It provides information in analog graphic gauges and digital displays for enhanced user experiences.

1.2 Components

- Refer to the components for this digital panel below table1-1

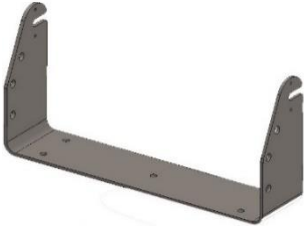
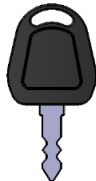
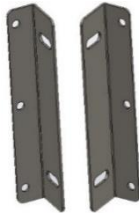
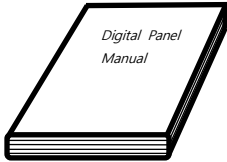
NO	Components	Name	NO	Components	Name
1		Digital Panel	4		Desk Mounting Type Parts 2SET
2		Desk Mounting Type Bracket	5		Key 2EA
3		Flush Mounting Type Bracket 2EA	6		User Manual

[Table 1-1]

1. General Information

1.3 Product Specification

- Refer to Table 1-2 below for the hardware specifications of this electronic engine digital panel.

Digital Panel Specification

No.	Item	Description
1	Microprocessor	<ul style="list-style-type: none">• Cortex-A8, dsPIC33FJ256
2	Software	<ul style="list-style-type: none">• Windows CE 6.0 R2
3	Display	<ul style="list-style-type: none">• 10.2" Color TFT LCD• 800 * 480 (Pixels)• 16:9
4	Flash Memory	<ul style="list-style-type: none">• 256MB (Flash)• 8GB (MicroSD card)
5	RAM	<ul style="list-style-type: none">• 512MB
6	Operating Voltage	<ul style="list-style-type: none">• DC 24V (16 to 30V)
7	USB	<ul style="list-style-type: none">• USB 2.0 1 Port
8	Operating Temperature	<ul style="list-style-type: none">• - 20°C to 70°C
9	Internal Buzzer	<ul style="list-style-type: none">• Piezo Buzzer 98dB
10	Communication	<ul style="list-style-type: none">• J1939 CAN Communication• RS232
11	Dimensions	<ul style="list-style-type: none">• W 343.5 x H 270.5 x D 120

[Table 1-2]

2. Product Installation

2.1 Cautions

- Unskilled personnel should read this manual before use.
- Do not use or keep the product close to combustible sprays or inflammable.
- Use soft and dry cloth to clean the monitor.
- Turn off the product, pull out the harness cable and then contact our service center when you see smoke from the monitor or have strange smells.
- When you see an alarm on, you always need to check the product before operation.
- Do not disassemble the product cover at discretion (warranty does not cover unauthorized disassembly).
- Excessive impact may damage the display although a reinforced display is used.
- Use connectors matching each other when connecting them to the back of the product.
- Do not contact or remove connectors while the power is on. It may cause electric shock or lead to malfunction.
- Do not exercise excessive force when rotating to ON/OFF with the key inserted.
- Do not use the product with wet hands.
- Use protective caps for back side connectors that are not used.

2. Product Installation

2.2 Desk Mounting Type

- Desk Mounting types are installed in the bridge by using Desk Mounting brackets delivered with the product.

※ Mounting Hole Spec : M6 bolt

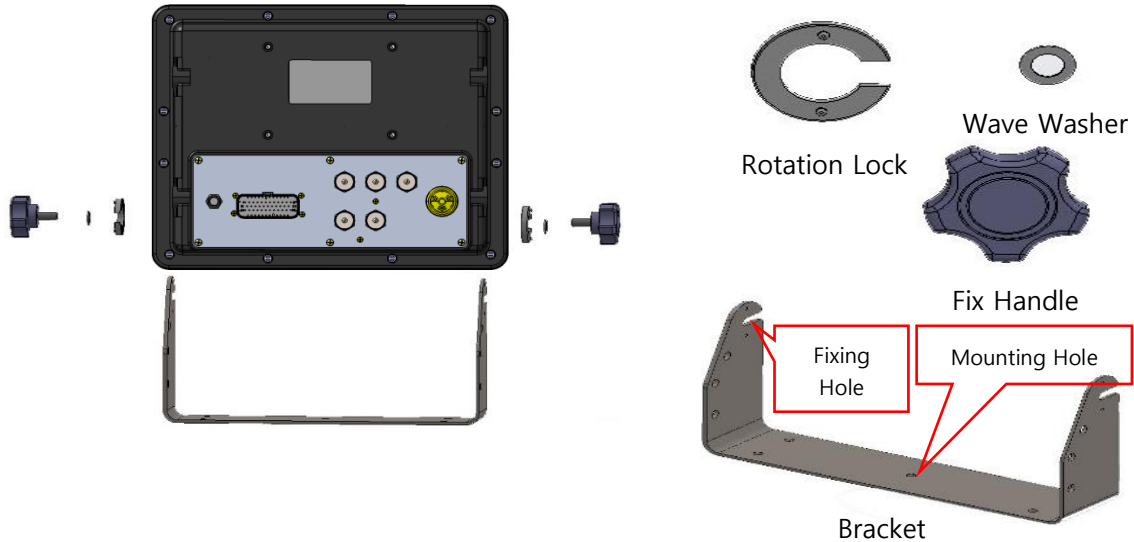

[Fig. 2-1] Desk Mounting Type Diagram

► Installing Desk Mounting type digital panel

- ① Check whether the bridge has engine harness wiring.
- ② Use the mounting hole to fix the bracket in a place within reach of the engine harness wiring.
- ③ Place the product inside the bracket connected with the rotation lock to connect it with the rotation lock.
- ④ Put the wave washer in the fix handle and connect it with the fix handle to the direction indicated by an arrow and adjust the viewing angle of the LCD.

※ Where there are things to which the product can be fixed, use spare holes with the bolt or other accessories.

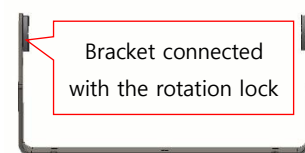

[Fig. 2-2]

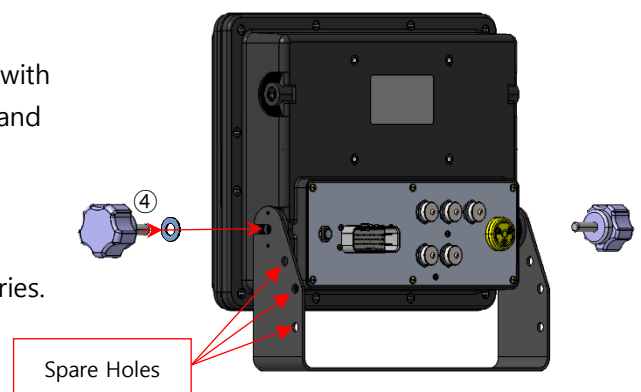

[Fig. 2-3]

2. Product Installation

2.3 Flush Mounting Type

- Flush Mounting types are installed in the bridge by using optional mounting brackets (2pcs).
※ Bolt Spec: ① M6 ② M8, Length - 12mm



[Fig. 2-4] Flush Mounting Type Diagram

► Installing Flush Mounting type digital panel

- ① Check whether the bridge has engine harness wiring.
- ② As shown in Fig. 2-6, fix the mounting brackets to both sides of the panel.
- ③ Check the location within reach of the engine harness wiring and the mounting location and then mount the panel using proper bolts.
- ④ Finish gaps between the product and the structure depending on the mounting conditions and connect the engine harness (you may connect the engine harness first depending on conditions).

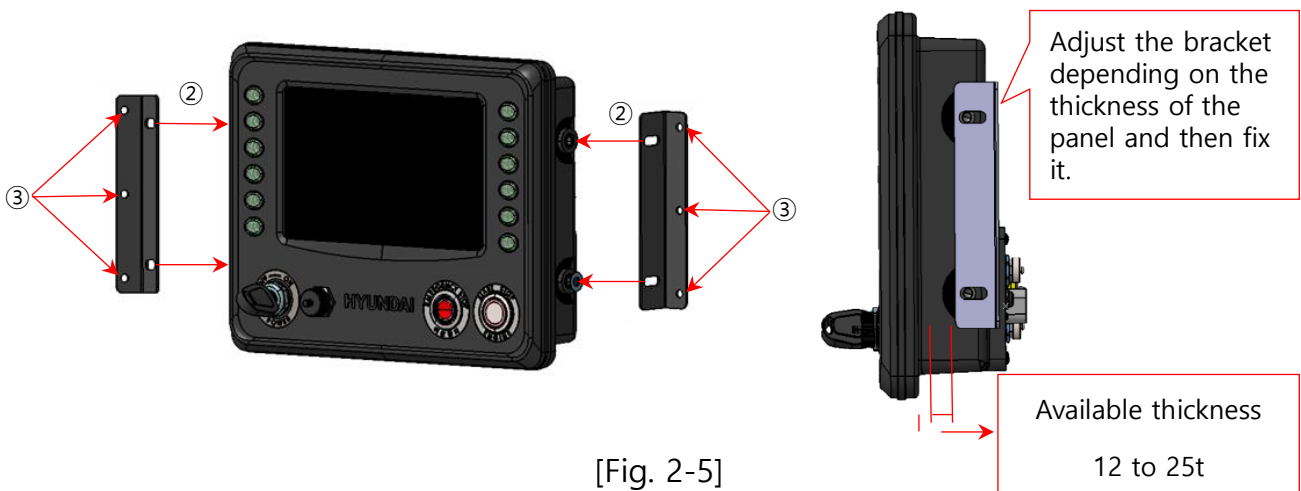

[Fig. 2-5]

3. Part Names, Operation and Settings

3.1 Front

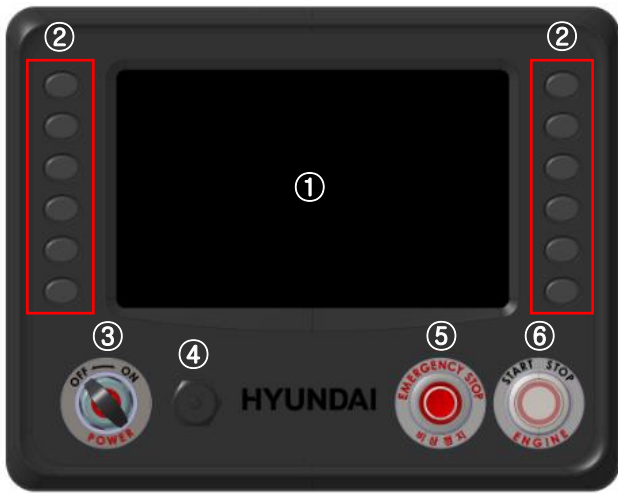

[Fig. 3-1]

No.	Name	Reference
①	LCD	-
②	Function Keys	Page 13
③	Key Switch	Page 11
④	USB	Page 10
⑤	Emergency Stop	Page 12
⑥	Start Button	Page 12

[Table 3-1]

3.2 Rear

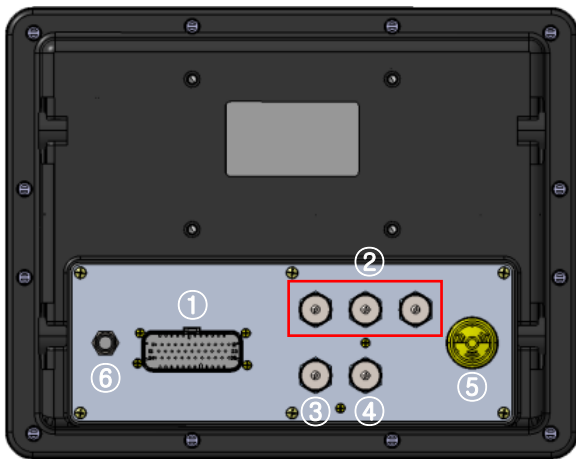

[Fig. 3-2]

No.	Name	Reference
①	Main Connector	Page 9
②	CAN/RS-232	Page 10
③	Engine Control(Only for e-Digital Panel for generators)	-
④	External Buzzer	Page 10
⑤	Built in Buzzer	Page 11
⑥	Fuse	Page 11

[Table 3-2]

3. Part Names, Operation and Settings

3.3 External Connection Terminals

- Input/output connector for engine control signal and sensor signal with ECU

3.3.1 Main Connector

- I/O connector for engine control signal and sensor signal to ECU.

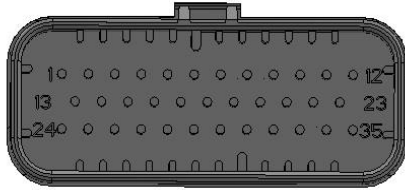

[Fig. 3-3]

No.	Pin Description	Remark	No.	Pin Description	Remark
1	Start Signal	-	19	Water In Fuel Switch	-
2	Battery(+)(DC 24V)	Fuse In	20	GND	-
3	Battery(+)(DC 24V)	Fuse In	21	-	-
4	Key On	-	22	-	-
5	Wait To Disconnect Suply	-	23	-	-
6	Wait To Disconnect	-	24	GND	-
7	-	-	25	GND	-
8	-	-	26	-	-
9	-	-	27	-	-
10	Fuel Leakage Switch	-	28	EMG Stop Button Supply	-
11	CAN2 H	-	29	EMG Stop Button Signal	-
12	CAN2 L	-	30	-	-
13	Alternator	-	31	-	-
14	Battery(+)(DC 24V)	GOPS SUPPLY	32	-	-
15	-	-	33	GND	-
16	-	-	34	GND	-
17	Gearbox Oil Pressure	Sensor	35	GND	-
18	GND	-	-	-	-

[Table 3-3]

3. Part Names, Operation and Settings

3.3.2 CAN Communication Connector

- CAN harness (optional) connection
- CAN1 / CAN2 : for multi panels
- CAN3 : PC communication, firmware download, Spare CAN

No.	CAN1	CAN2	CAN3
1	+12V Out	+12V Out	+12V Out
2	GND	GND	GND
3	CAN1_H	CAN1_H	CAN2_H
4	CAN1_L	CAN1_L	CAN2_L
5	Battery (+)	Battery (+)	PC_RXD1
6	GND	GND	PC_TXD1

[Table 3-4]



[Fig. 3-4]

3.3.3 External Buzzer Connector

- Additional connection for external buzzer harness
- Generating external buzzer alarms for warnings

No.	Name
1	Battery (+) – Fuse Output
2	Alarm Out

[Table 3-5]

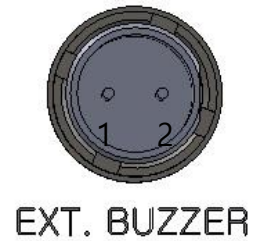

[Fig. 3-5]

3.3.4 USB Connector

- USB memory can be inserted for data backup and S/W upgrade.
(Only FAT32 format available)



USB
[Fig. 3-6]

3. Part Names, Operation and Settings

3.4 Fuse and Internal Buzzer

3.4.1 Fuse

- Shut down the power for overcurrent exceeding 5A
- Press the fuse button for 10 seconds to restore fuse operation.

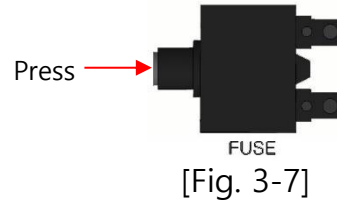

3.4.2 Internal Buzzer

- Generate alarms for sensor problems



3.5 Key Switch

- Key switch is used to boot, turn off the digital panel system and stop the engine.
 - 1) Use the key contained in the product to insert it and rotate to the right by 45~90° (ON) (when the key is ON, the key should remain inserted).
 - 2) When the key is ON, the product will boot and the gauge display will appear in about 17 seconds.
 - 3) Rotate the key to the left by 90° (OFF) to turn it off.
 - When rotating the key to the left (OFF) while ECU running, the display will show a popup message Fig3-11 for Wait To Disconnect. The engine will stop with digital panel power off simultaneously.
 - When the popup window appears, rotate the key to the right (ON) to remove the window and keep the engine on.

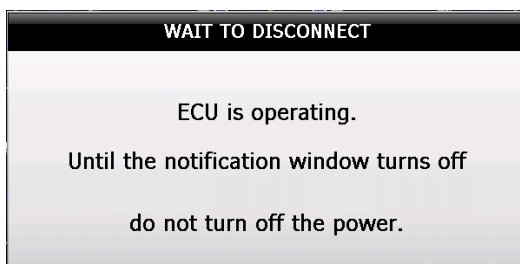
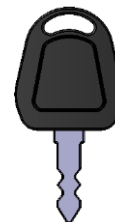

[Fig. 3-11]



Key Switch
[Fig. 3-10]

3. Part Names, Operation and Settings

3.6 Start Button

- Start button is used to start control for the engine.
 - 1) Press the button for more than 1 second while the key is ON, the engine will start (the button LED will flash when pressing the button).
 - ※ You can set the time to 1~3 second for emergency response in Digital Panel Manager.
 - ※ Plastic protection cover label installed.
 - ※ Be careful of strong force because it can be confirmed by LED flashing during pushing operation.

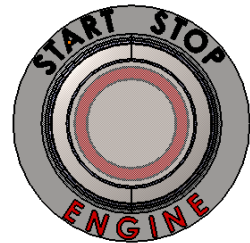

Start Button
[Fig. 3-12]

3.7 Emergency Stop Button

- Emergency Stop Button is used to urgent engine stop for the emergency situation.
 - 1) Press immediately when an emergency situation occurs in the engine run state.
 - Red LED on while pressing
 - 2) Engine RPM drops while depressed.
 - 3) Release the button after the engine is completely stopped.
 - LED off when released
 - ※ If you release the button before stopping the engine, the engine will restart.



Emergency Stop
Button
[Fig. 3-13]

3. Part Names, Operation and Settings

3.8 Function Keys

- Function keys are used to adjust LCD brightness, stop alarming (mute), Close Fault Code Pop-up, Digit, Home and other settings, move to and select menus, and reset the system.

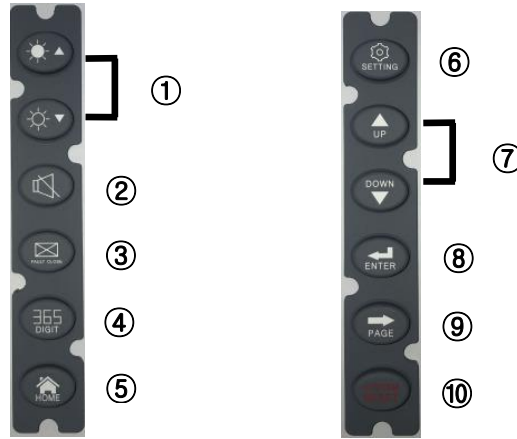

[Fig. 3-14] Function Keys

No.	Function Key	Action Feature
①	LCD dimmer	<ul style="list-style-type: none"> LCD brightness adjustable for 5 different levels (when rebooting the system, the previous setting will be maintained).
②	Alarm Mute	<ul style="list-style-type: none"> Turn off the buzzer sound
③	Fault Code Close	<ul style="list-style-type: none"> Closing the Fault Code window displays all the fault messages from ECU
④	Digit On/Off	<ul style="list-style-type: none"> Default On Press once : number light will be off Press once again : number light will be on
⑤	Home	<ul style="list-style-type: none"> Move to main gauge display. Move to main display without saving when pressing it in page mode.
⑥	Configuration	<ul style="list-style-type: none"> Engine Model setting Master/Slave setting and ON/OFF setting to start the slave USB backup and time (year/month/hour) settings Convert Korean/English Set date
⑦	Up/Down	<ul style="list-style-type: none"> Move the cursor up and down in setting window
⑧	Select	<ul style="list-style-type: none"> Select menus or functions in the setting window
⑨	Page	<ul style="list-style-type: none"> Move to spare sensor display (display page 2) / Move to event summary display (display page 3)
⑩	System Reboot	<ul style="list-style-type: none"> Rebooting for system errors (press it for more than 3 seconds to reboot)

[Table 3-6]

3. Part Names, Operation and Settings

3.8.1 Detailed Settings

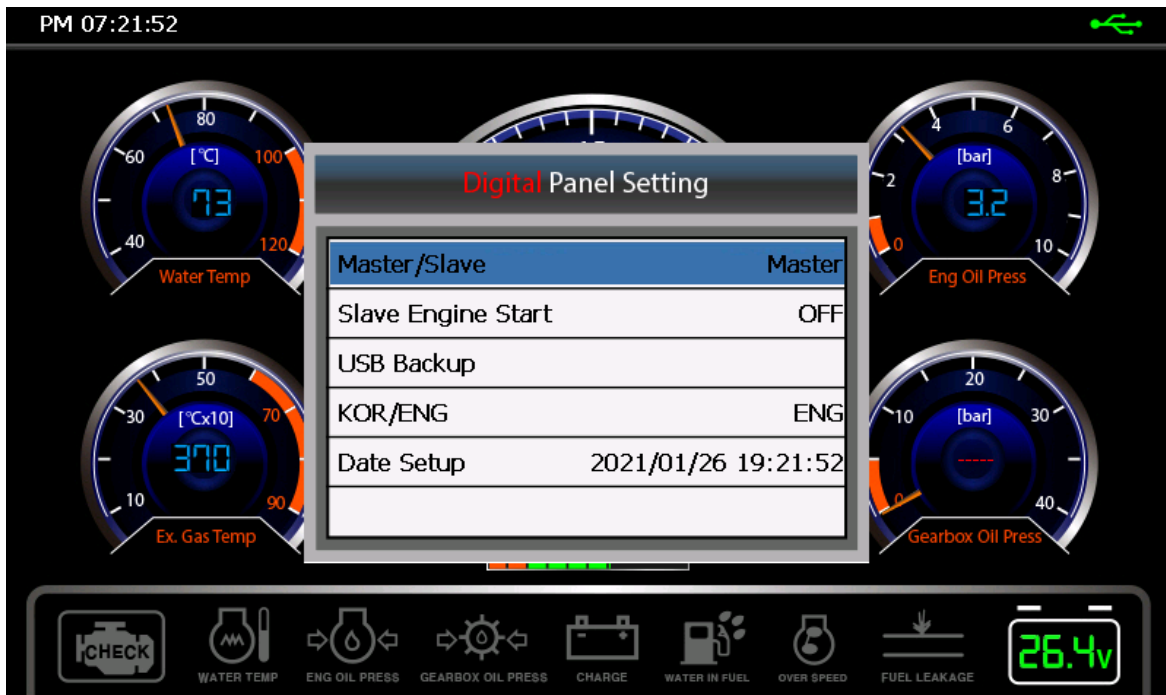

[Fig. 3-15] Detailed Settings

► Setting Functions and Descriptions

- Press button and then use or button to move to functions to be changed.
- Press button to go back to gauge display (changes will be automatically saved).

No.	Function	Description	Function Key
1	Master / Slave	• Master/Slave setting for multi panels	
2	Slave Engine Start	• ON/OFF setting to start from the slave	
3	USB Back Up	• USB backup for event save files	
4	KOR/ENG	• Convert Korean to English	
5	Date Setup	• Date and time setting	

[Table 3-7]

3. Part Names, Operation and Settings

3.9 Display Structure

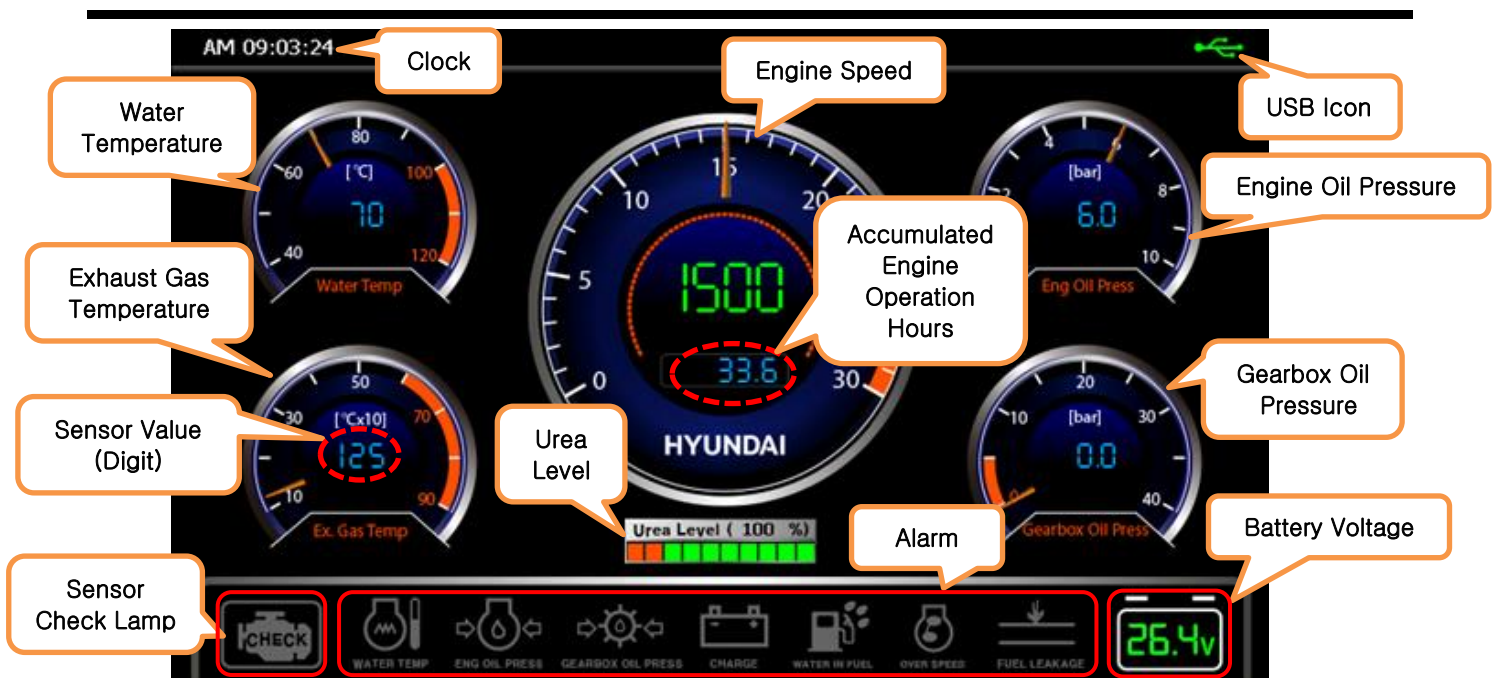

[Fig. 3-16] Gauge Display

- Gauge display shows various gauge data including pick up (RPM) sensor, coolant temperature, exhaust gas temperature, engine oil pressure, Ureal Level and gearbox oil pressure.
- It also includes Current Clock, battery voltage indication, accumulated engine operation hours, coolant temperature, engine oil pressure, gearbox oil pressure, charging, fuel leakage and overspeed alarms.

3.9.1 Engine Speed (Tachometer)

- It shows engine RPM in gauge and digital values and counts accumulated engine operation hours.

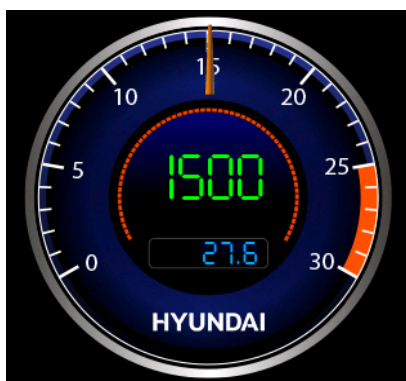

[Fig. 3-17]

Engine Speed Gauge

- 1) It shows the RPM indicated by the gauge hand in digital values (green) for better accuracy (however, it is available off by the 'DIGIT' button).
- 2) It shows Fault Code P0219 when engine speed is over.
→ Engine overspeed detection error
- 3) It shows accumulated engine operation hours by hour unit (engine speed of 1RPM or faster will be counted and the function is always on)

3. Part Names, Operation and Settings

3.9.2 Engine Water Temperature

- It shows the coolant temperature in gauge and digital values.



[Fig. 3-18]

- 1) It shows the temperature indicated by the gauge hand in digital values (blue) for better accuracy (however, it is available off by the 'DIGIT' button).
- 2) It shows Fault Code P0116 when engine speed is over.
➔ High coolant temperature error Alarm
- 3) It activates alarm and warning beep when under alarm conditions from ECU.

Engine Water Temperature Gauge

3.9.3 Engine Oil Pressure

- It shows engine oil pressure in gauge and digital values.



[Fig. 3-19]

Engine Oil Pressure Gauge

- 1) It shows the pressure indicated by the gauge hand in digital values (blue) for better accuracy (however, it is available off by the 'DIGIT' button).
- 3) It activates alarm and warning beep when the pressure is 1bar or lower.
- 4) When the pressure is 0.5bar or lower, the engine will stop(detects in 10 seconds).
- 5) It shows Fault Code P1521 when engine speed is over.
➔ Low oil pressure error

3.9.4 Exhaust Gas Temperature

- It shows exhaust gas temperature in gauge and digital values.



[Fig. 3-20]

Exhaust Gas Temperature

- 1) It shows the temperature indicated by the gauge hand in digital values (blue) for better accuracy (however, it is available off by the 'DIGIT' button).

3. Part Names, Operation and Settings

3.9.5 Gearbox Oil Pressure

- It shows gearbox oil pressure in gauge and digital values.



[Fig. 3-21]

Gearbox Oil Pressure

- 1) It shows the pressure indicated by the gauge hand in digital values (blue) for better accuracy (however, it is available off by the 'DIGIT' button).
- 2) It shows the open/short diagnosis for sensor problems.
 - ☞ Open: '- - - - -' / Short (Power): 'ERROR'
- 3) It activates alarm and warning beep when the pressure is 1bar or lower (detects in 10 seconds).

3.9.6 Battery Voltage

- It shows battery voltage to indicate its conditions.



[Fig. 3-22] Battery Voltage

- 1) It will show in green for voltage of 24V or higher or red for voltage lower than 24V.
- 2) It activates warning beep when the low voltage with fault code P0562.

➔ Low battery voltage error

3.9.7 Check Sensor Light

- When there are sensor errors (Open or Short), the check sensor light will turn on.



[Fig. 3-23] Check Sensor Light

- 1) When the check sensor light is on, it will show in red.

※ Open and Short gauge displays for sensor problems

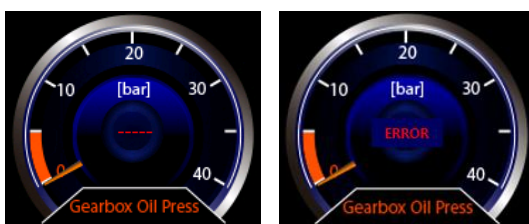

Open

Short

3. Part Names, Operation and Settings

3.9.8 Engine Alarms

- The alarm will be activated with buzzer beeping when problems for coolant temperature, engine oil pressure, gearbox oil pressure, charging, water in fuel, fuel leakage and over speed are detected.

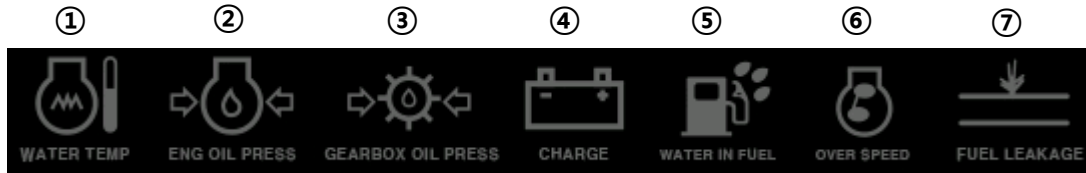

[Fig. 3-24] Engine Alarms

No.	Alarm	Action Feature
①	Coolant temperature	• Alarm (buzzer) will be activated when the temperature is 93°C or higher
②	Engine oil pressure	• Alarm (buzzer) will be activated on when the pressure is 1 bar or lower
③	Gearbox oil pressure	• Alarm (buzzer) will be activated on when the pressure is 1 bar or lower
④	Charging	• Alarm (buzzer) will be activated when the battery voltage is lower than 27V
⑤	Water In Fuel	• Alarm (buzzer) will be activated when the WIF switch is on
⑥	Engine over speed	• Alarm (buzzer) will be activated when the speed exceeds 110% of the rate speed
⑦	Fuel leakage	• Alarm (buzzer) will be activated when oil leak occurs (default setting is 'disabled')

[Table 3-8] Alarm Features

※ How to deactivate the engine alarm

- Press SYSTEM RESET button on the right for 3 seconds, the system will reboot and the alarm will be deactivated (rebooting is available while the ship navigates without causing problems).

3.9.9 Engine Shutdown

- 1) When the over speed exceeds **110%** of the rate speed
- 2) When the coolant temperature exceeds **105°C**
- 3) When the oil pressure is **0.5bar** or lower
- 4) When fuel leakage occurs
- 5) When the engine is normally stopped, key-off from the panel or other ECU is determined to be necessary

3. Part Names, Operation and Settings

3.10 Sensor etc.

- It identifies the status of the other sensors, product S/N, ECU MAP VERSION and GUI/FIRMWARE version. To see this page, press  button from main page.

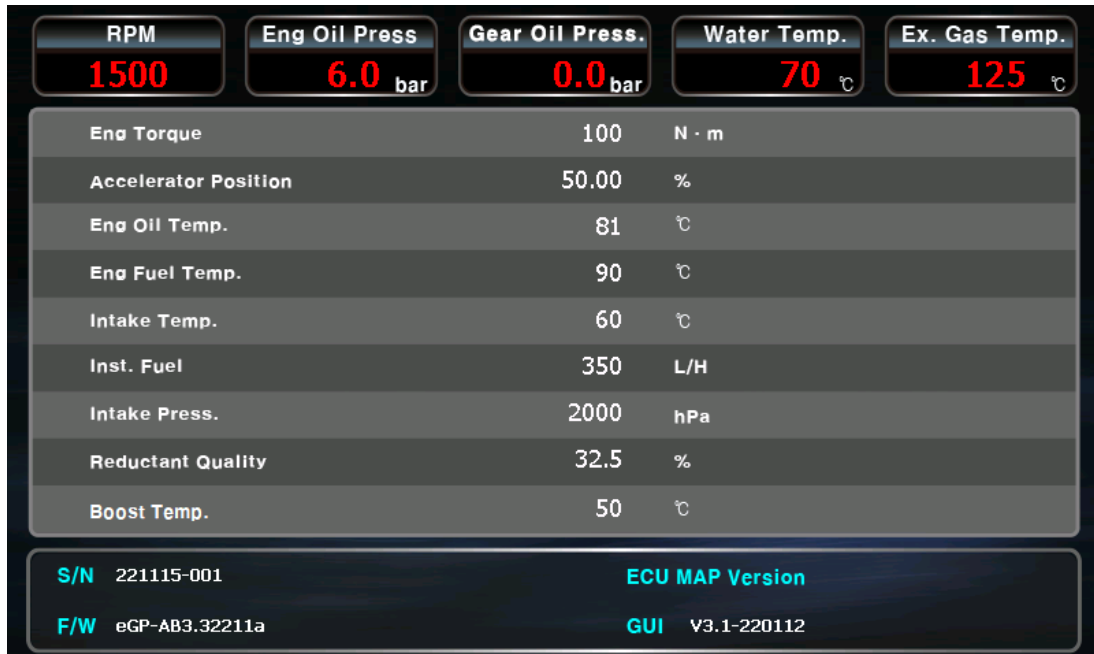

[Fig. 3-25] Other Sensors and S/W information

Item	Condition
Engine Torque	• Current torque of the engine, expressed in Nm
Accelerator Position	• Accelerator position, expressed in%
Engine Oil Temperature	• Engine oil temperature and marked above -40°C
Engine Fuel Temperature	• Engine fuel temperature and marked above -40°C
Intake Temperature	• Intake manifold temperature and marked above -40°C
Instantaneous Fuel	• Instant fuel consumption rate, expressed in L/H
Intake Pressure	• Booster pressure, expressed in bar
Reductant Quality	• Urea concentration, expressed in%
Boost Temperature	• Boost Temperature and marked above -40°C

[Table 3-9] Sensors Conditions

3. Part Names, Operation and Settings

3.11 Fault Code Information

- ECU detects whether there is an abnormality in the engine while the engine is running, and when a fault condition is met, the fault code is transmitted through CAN communication, and the code is received from the digital panel, and the fault code and fault details are output to the monitor as shown in Figure 3-26.
- Figure 3-26 displays all faults received in real time.
- The fault code alarm window in Figure 3-27 appears on the screen when a fault code occurs, regardless of which page the user is working on.

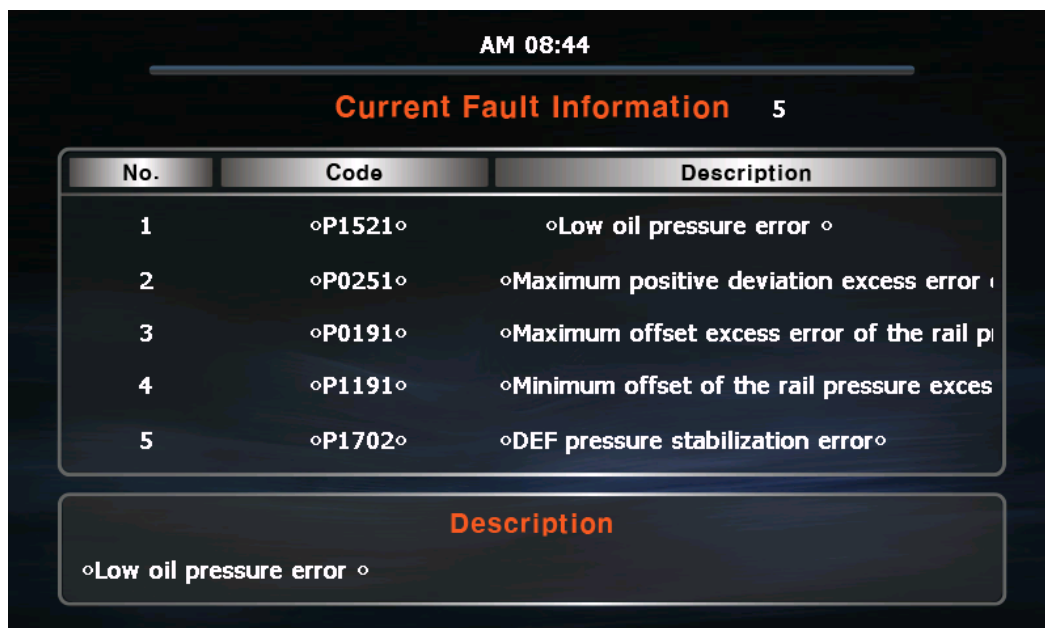

AM 08:44

Current Fault Information 5

No.	Code	Description
1	◦P1521◦	◦Low oil pressure error ◦
2	◦P0251◦	◦Maximum positive deviation excess error ◦
3	◦P0191◦	◦Maximum offset excess error of the rail pi
4	◦P1191◦	◦Minimum offset of the rail pressure exces
5	◦P1702◦	◦DEF pressure stabilization error◦

Description

◦Low oil pressure error ◦

[Fig. 3-26] Fault Code List

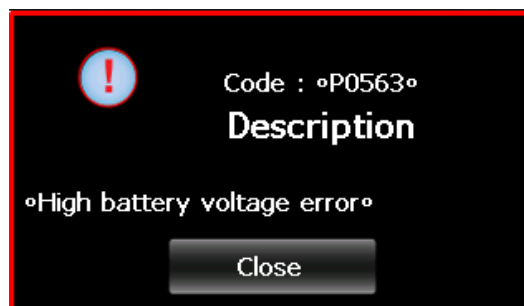

[Fig. 3-27] Fault Code pop-up window

3. Part Names, Operation and Settings

3.12 Event Summary

- It shows the numbers of normal operations, normal stops, emergency stops and sensor errors together with dates of recent errors.
- Press  button in spare sensor page to move to event summary page.

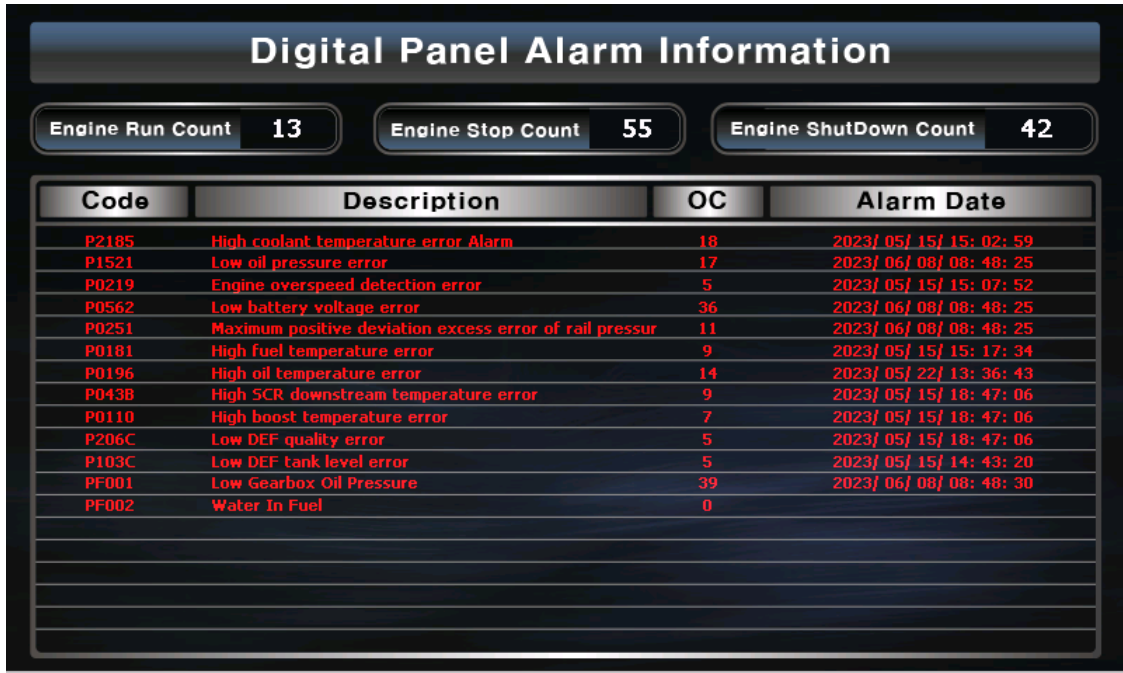

[Fig. 3-28] Event Summary Screen

Event List			
P2185	High coolant temperature error Alarm	P043B	High SCR downstream temperature error
P1521	Low oil pressure error	P0110	High boost temperature error
P0219	Engine overspeed detection error	P206C	Low DEF quality error
P0562	Low battery voltage error	P103C	Low DEF tank level error
P0251	Maximum positive deviation excess error of rail pressure	PF001	Low Gearbox Oil Pressure
P0181	High fuel temperature error	PF002	Water In Fuel
P0196	High oil temperature error		

[Table 3-10] Event List

3. Part Names, Operation and Settings

3.13 System Booting and Functional Check

- You can check whether the product is properly installed or not.

▶ Normal System Booting

- 1) Insert the key into the key switch and rotate it to the right (ON).
- 2) HYUNDAI logo will appear for 15 seconds while the system is booting (refer to the image).
 - ※ If the logo does not appear after rotating the key,
 - Rotate it to the left (OFF) and then to the right (ON) again
 - Check the harness connection at the back of the panel
 - Check whether the battery is discharged
- 3) The gauge display will appear after normal booting.
 - Gauge: check whether each gauge hand is within the normal range and 'ERROR' or '-----' is displayed on the screen.
 - ※ Where 'ERROR' or '-----' is displayed on the screen
 - Check the harness connection
 - Function keys: check whether each function key is active on the screen by pressing them.
 - Alarm: check whether the alarm is turned on.
 - Battery: Check whether the battery is ok.
- 4) Where the initial gauge screen is normal, press START button for 1 second to start the engine (the time can be set to 1~3 second. Refer to Digital Panel Manager).
- 5) Check whether the operation is in normal RPM (initial operation in 400RPM or faster with the oil pressure of 1bar or higher) and whether is turned on.

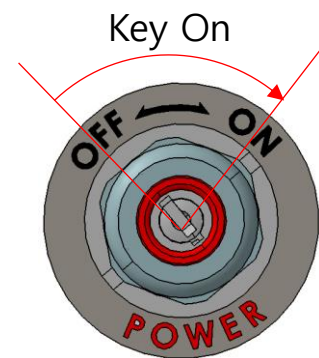

[Fig. 3-29] Key Switch



[Fig. 3-30] Booting Logo



[Fig. 3-31] Gauge Display

4. Multi Panel Structure

4.1 Multi Panels

- Panels can be installed up to 4 units except Master in the ship and you can check the ship conditions and control those panels at any places of installation.
- However, note that the battery voltage drops as the harness length increases.



4. Multi Panel Structure

4.2 How to Install Multi Panels

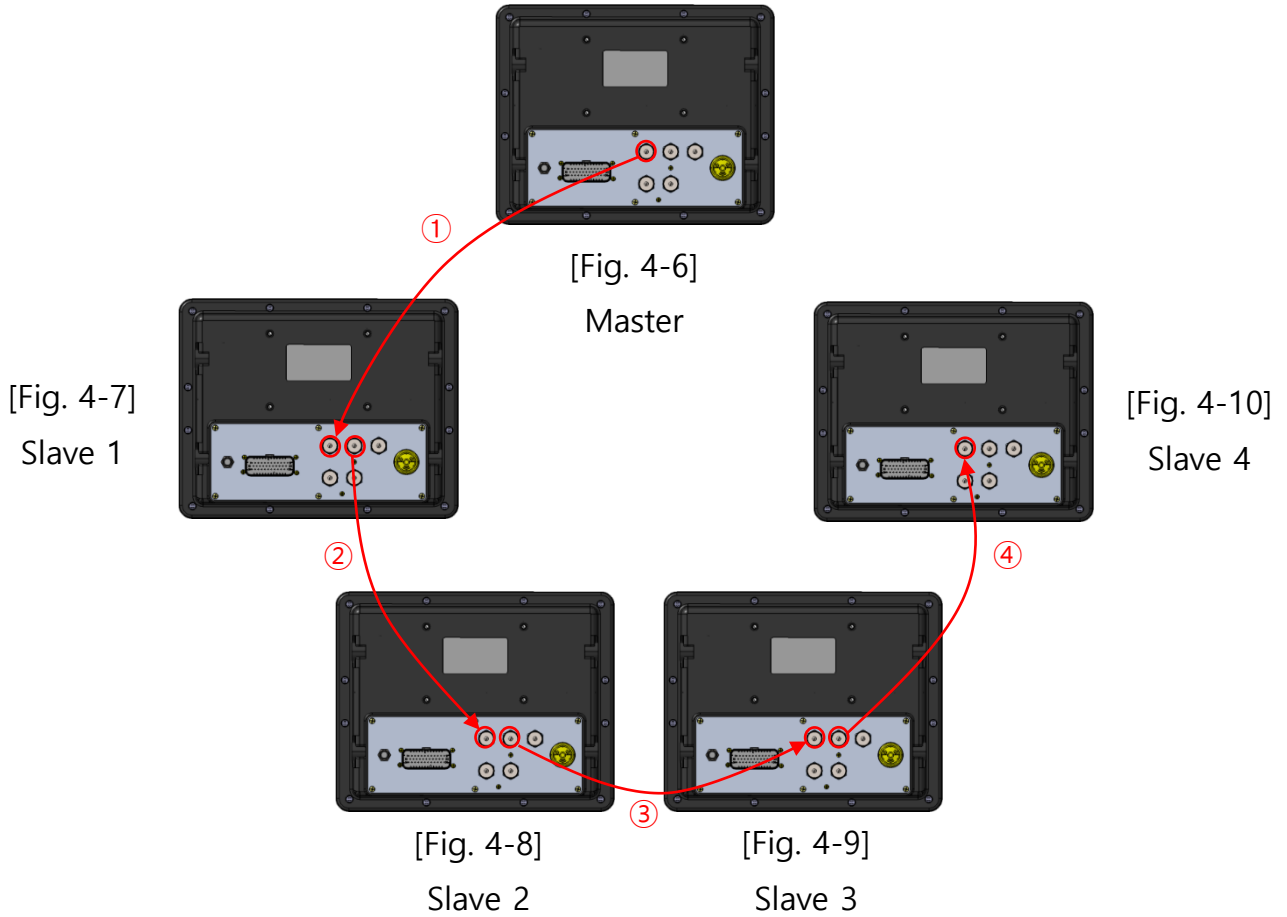

※ In order to install multi panels, all the necessary cables should be ready in advance (use the cables with specification recommended by HYUNDAI).

(1) Connect the CAN1 terminal of the Master panel and the CAN1 terminal of the Slave 1 panel as shown in ① (2 panels).

- Master and Slave 1 connection completed

(2) Connect Slave 1 (CAN1) and Slave 2 (CAN1) as shown in ② while maintaining connection as described in ① (3 panels).

- Master, Slave 1 and Slave 2 connection completed

(3) Connect Slave 2 (CAN2) and Slave 3 (CAN1) as shown in ③ while maintaining connection as described in ② (4 panels).





- Master, Slave 1, Slave 2 and Slave 3 connection completed

(4) Connect Slave 3 (CAN2) and Slave 4 (CAN1) as shown in ④ while maintaining connection as described in ③ (5 panels)

- Master, Slave 1, Slave 2, Slave 3 and Slave 4 connection completed

4. Multi Panel Structure

4.3 Multi Panel Settings

- (1) Press  button of the panel to be configured as Slave.
- (2) Move to ① when the setting screen appears (use  or  button to move).
- (3) Press  button to switch configuration between Master and Slave.
- (4) Configure the Master panel as described above.

※ Notes

- Master mode is available for one panel only and Slave mode is up to 2 units recommended.
- If the length of the harness between the Master and the Slave is more than 30m, the battery voltage drop may occur more than 1V, so check it.
- You can permit Slaves to start the engine with Master panel only. Where you enable Slave Engine Start setting, all Slave panels will be able to start the engine.

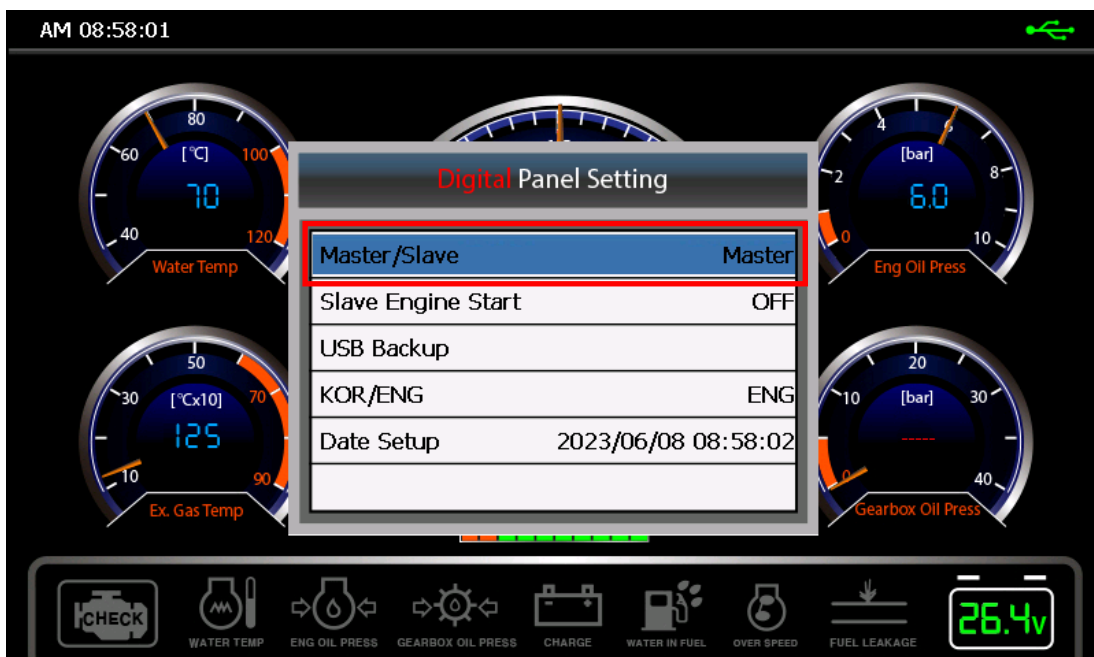

[Fig. 4-11] Multi Panel Setting Window

5. Maintenance

5.1 Maintenance

- To maintain the performance of the device, regular maintenance is required.
- 1. Use soft cloth to clean the LCD without damaging it.
 - 1) Clean the LCD after turning the power off.
 - 2) Do not use cleaners with acids or ammonia.
 - 3) Do not use neutral detergents to remove oil stains.
 - 4) Use cloth slightly wet in clean water to remove salt residuals or dust particles for natural drying. If there remain stains, clean them with soft cloth (microfibers) once again.
- 2. Check whether the connectors or harnesses at the back of the device are properly connected or whether they have dust or other foreign substances.
- 3. Check whether cables are damaged.
- 4. Request for checking when the software needs upgrade as follows:
 - When the manufacturer releases official software for performance improvements

5.2 Troubleshooting

- It describes possible measures for users to resolve problems while using the device.
- 1. The device is not turned on.
 - 1) Check whether harness cables at the back of the product are properly connected.
 - 2) Where harness cables have too much dust or moisture, remove them and clean the dust or moisture. Connect them once again after a while.
 - 3) Check whether the fuse button at the back of the product is pulled out.
 - 4) Check whether the battery is discharged.
- 2. You can see lines or shaking on the screen.
 - 1) Reboot the product.
 - 2) As the LCD is connected inside the product, do not disassemble it and contact the service team.
- 3. You can see alarm or hear warning beeps at the bottom of the product screen.
 - 1) Check where the alarm occurs and then take measures as necessary (if you need to confirm which alarm occurs, refer to Page 21 of this manual).
- 4. You cannot control buttons.
 - 1) Check whether there are foreign substances at the panel buttons.
 - 2) As the button connecting parts may be damaged, do not disassemble the product and contact the service team.

6. Warranty and A/S Service

6.1 Warranty

As this manual contains important contents related to safety, use and maintenance of the product. So please read this manual carefully and then use the product in a proper manner.

Those who are not familiar with the product should keep this manual close to it.

We are not responsible for human injuries or property damages caused by the following reasons:

- Where you use the product for purposes other than the ones described in this manual
- Where you alter the product or its components at discretion
- Where you disassemble the product at discretion to resolve problems
- Where you use accessories or parts not supplied or recommended by us
- ※ Where you use accessories or parts manufactured by other companies, please contact our service center to check their compatibility.

6.2 A/S Service Information

- When you request A/S service, please let us know the model name, breakdown conditions and your contact information.
- Please ask the seller.

Digital Panel for Electronic Marine Generator's User Manual

Ver.1.1



HYUNDAI

► Contents

1. General Information	
1.1 Product Information	3
1.2 Components	3
1.3 Product Specification	4
2. Product Installation	
2.1 Cautions	5
2.2 Desk Mounting Type	6
2.3 Flush Mounting Type	7
3. Part Names, Operation and Settings	
3.1 Front Side	8
3.2 Back Side	8
3.3 External Connection Terminals	9
3.3.1 Main Connector	9
3.3.2 Circular Connector	10
3.3.3 USB Connector	10
3.4 Fuse and Internal Buzzer	11
3.4.1 Fuse	11
3.4.2 Internal Buzzer	11
3.5 Key Switch	11
3.6 Start/Stop Button	12
3.7 Emergency Stop Button	12
3.8 Function Keys	13
3.8.1 Detailed Settings	14
3.8.2 Engine Control Settings	15
3.9 Display Structure	17
3.9.1 Engine Speed (Tachometer)	17
3.9.2 Engine Water Temperature	18
3.9.3 Engine Oil Pressure	18
3.9.4 Exhaust Gas Temperature	18
3.9.5 Battery Voltage	19
3.9.6 Sensor Check Lamp	19
3.9.7 Engine Alarm	19
3.9.8 Engine Stop	20
3.10 Sensor etc.	21
3.11 Fault Code Information	22

► Contents

3.12	Event Summary	-----	23
3.13	System Booting and Functional Check	-----	24
4. Multi Panel Structure			
4.1	Multi Panel	-----	25
4.2	How to Install Multi Panels	-----	26
4.3	Multi Panel Settings	-----	27
5. Maintenance			
5.1	Maintenance	-----	28
5.2	Troubleshooting	-----	28
6. Warranty and A/S Service			
6.1	Warranty	-----	29
6.2	A/S Service Information	-----	29

1. General Information





1.1 Product Information

The name of the product model is a digital panel applicable to electronic generator engine type ships and other various marine e-engines. The product is intended to improve problems of existing analog panels and allow users to check engine controls and conditions by means of a digital visualization product. It provides information in analog graphic gauges and digital displays for enhanced user experiences.

1.2 Components

- Refer to the components for this digital panel below table1-1

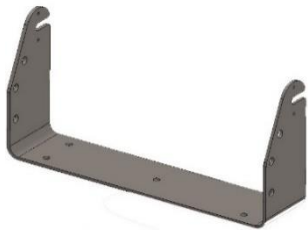
Components

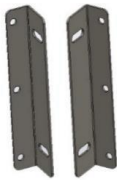
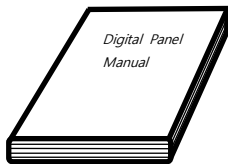
NO	Components	Name	NO	Components	Name
1		Digital Panel	4		Desk Mounting Type Parts 2SET
2		Desk Mounting Type Bracket	5		Key 2EA
3		Flush Mounting Type Bracket 2EA	6		User Manual

[Table 1-1]

1. General Information

1.3 Product Specification

- Refer to Table 1-2 below for the hardware specifications of this electronic engine digital panel.

Digital Panel Specification

No.	Item	Description
1	Microprocessor	<ul style="list-style-type: none">Cortex-A8, dsPIC33FJ256
2	Software	<ul style="list-style-type: none">Windows CE 6.0 R2
3	Display	<ul style="list-style-type: none">10.2" Color TFT LCD800 * 480(Pixels)16 : 9
4	Flash Memory	<ul style="list-style-type: none">256MB(Flash)8GB(MicroSD card)
5	RAM	<ul style="list-style-type: none">512MB
6	Operating Voltage	<ul style="list-style-type: none">DC 24V (16 ~ 32V)
7	USB	<ul style="list-style-type: none">USB 2.0 1Port
8	Operating Temperature	<ul style="list-style-type: none">- 20°C ~ 70°C
9	Internal Buzzer	<ul style="list-style-type: none">Piezo Buzzer 98dB
10	Communication	<ul style="list-style-type: none">J1939 CAN CommunicationRS232
11	Dimensions	<ul style="list-style-type: none">W 343.5 x H 270.5 x D 120

[Table 1-2]

2. Product Installation

2.1 Cautions

- Unskilled personnel should read this manual before use.
- Do not use or keep the product close to combustible sprays or inflammable.
- Use soft and dry cloth to clean the monitor.
- Turn off the product, pull out the harness cable and then contact our service center when you see smoke from the monitor or have strange smells.
- When you see an alarm on, you always need to check the product before operation.
- Do not disassemble the product cover at discretion (warranty does not cover unauthorized disassembly).
- Excessive impact may damage the display although a reinforced display is used.
- Use connectors matching each other when connecting them to the back of the product.
- Do not contact or remove connectors while the power is on. It may cause electric shock or lead to malfunction.
- Do not exercise excessive force when rotating to ON/OFF with the key inserted.
- Do not use the product with wet hands.
- Use protective caps for back side connectors that are not used.

2. Product Installation

2.2 Desk Mounting Type

- Desk Mounting types are installed in the bridge by using Desk Mounting brackets delivered with the product.

※ Mounting Hole Spec: M6 bolt

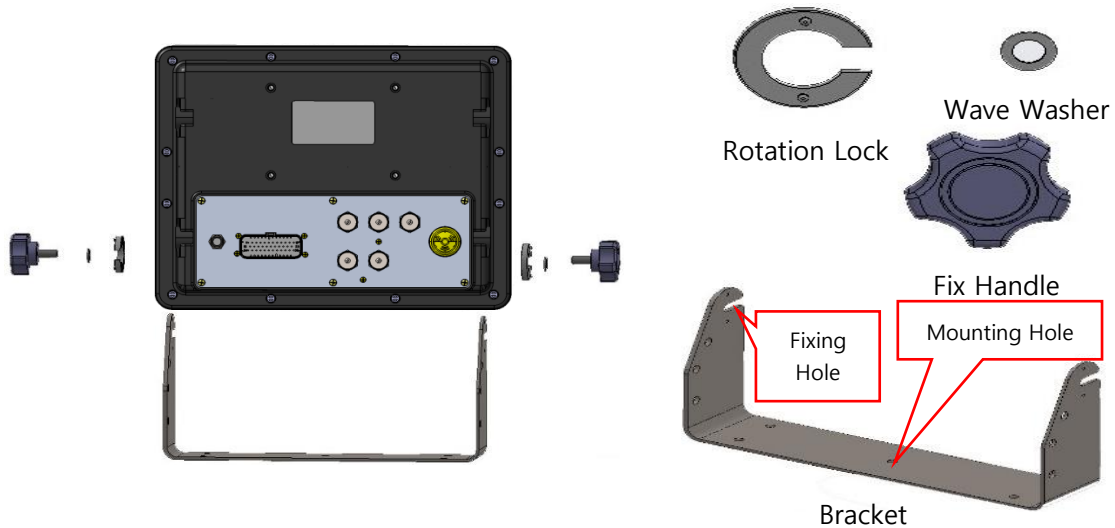

[Fig. 2-1] Desk Mounting Type Diagram

▶ Installing Desk Mounting type digital panel

- ① Check whether the bridge has engine harness wiring.
- ② Use the mounting hole to fix the bracket in a place within reach of the engine harness wiring.
- ③ Place the product inside the bracket connected with the rotation lock to connect it with the rotation lock.
- ④ Put the wave washer in the fix handle and connect it with the fix handle to the direction indicated by an arrow and adjust the viewing angle of the LCD.

※ Where there are things to which the product can be fixed, use spare holes with the bolt or other accessories.

⑤

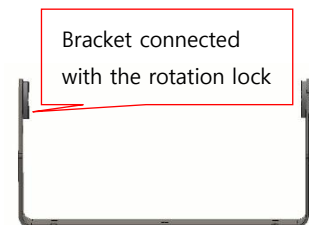

[Fig. 2-2]

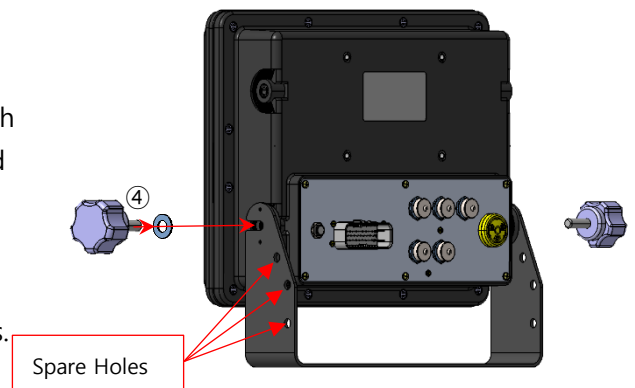

[그림 2-3]

3. Part Names, Operation and Settings

2.3 Flush Mounting Type

- Flush Mounting Types are installed in the bridge by using optional mounting brackets (2pcs).
※Bolt Spec: ① M6 ② M8, Length-12mm



[Fig. 2-4] Flush Mounting Type Diagram

► Installing Flush Mounting Type digital panel

- ① Check whether the bridge has engine harness wiring.
- ② As shown in Fig. 2-6, fix the mounting brackets to both sides of the panel.
- ③ Check the location within reach of the engine harness wiring and the mounting location and then mount the panel using proper bolts.
- ④ Finish gaps between the product and the structure depending on the mounting conditions and connect the engine harness (you may connect the engine harness first depending on conditions).

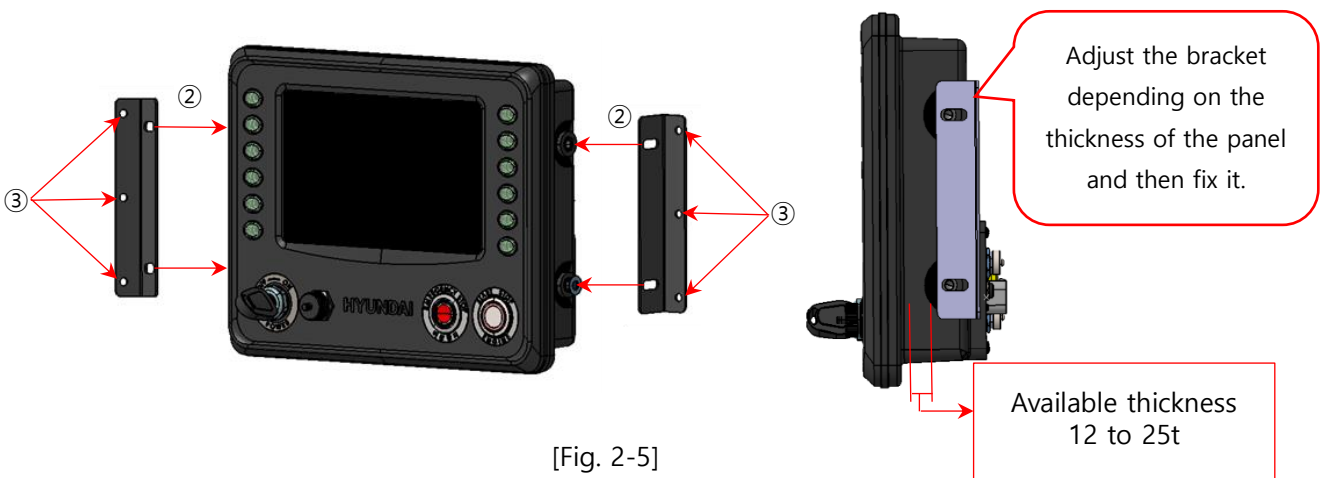

[Fig. 2-5]

3. Part Names, Operation and Settings

3.1 Front

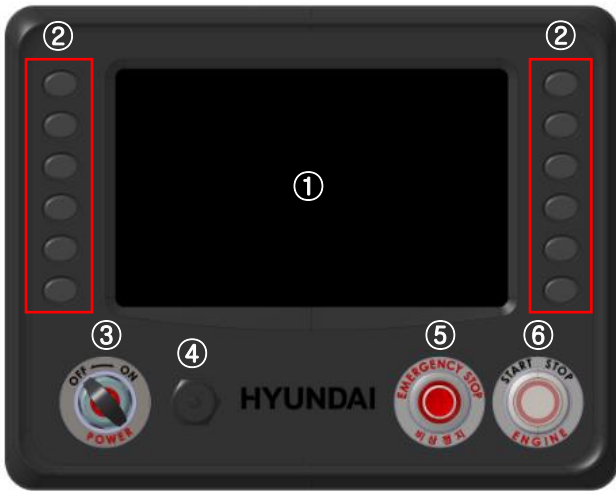

[Fig. 3-1]

No.	Name	Reference
①	LCD	-
②	Function Keys	13 Page
③	Key Switch	11 Page
④	USB	10 page
⑤	Emergency Stop	12 Page
⑥	Start/Stop Button	12 Page

[Table 3-1]

3.2 Rear

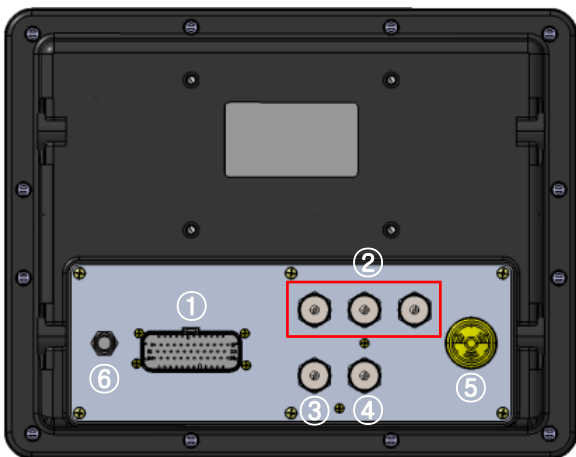

[Fig. 3-2]

No.	Name	Reference
①	Main Connector	9 Page
②	Circular Connectors (CAN / RS-232)	10 Page
③	Engine Control	10 Page
④	External Buzzer	10 Page
⑤	Built in Buzzer	11 Page
⑥	Fuse	11 Page

[Table 3-2]

3. Part Names, Operation and Settings

3.3 External Connection Terminals

- Input/output connector for engine control signal and sensor signal with ECU

3.3.1 Main Connector

- Input/Output connector for engine control signals and sensor signals to ECU.

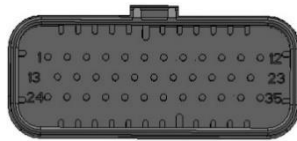

[Fig. 3-3]

No.	Pin Description	Remark	No.	Pin Description	Remark
1	Start Signal	-	19	Water In Fuel Switch	-
2	Battery(+)(DC 24V)	Fuse In	20	GND	-
3	Battery(+)(DC 24V)	Fuse In	21	-	-
4	Key On	-	22	-	-
5	Wait To Disconnect Suply	-	23	-	-
6	Wait To Disconnect	-	24	GND	-
7	-	-	25	GND	-
8	-	-	26	-	-
9	-	-	27	-	-
10	Fuel Leakage Switch	-	28	EMG Stop Button Supply	-
11	CAN2 H	-	29	EMG Stop Button Signal	-
12	CAN2 L	-	30	-	-
13	Alternator	-	31	-	-
14	Battery(+)(DC 24V)	GOPS SUPPLY	32	-	-
15	-	-	33	GND	-
16	-	-	34	GND	-
17	-	-	35	GND	-
18	GND	-	-	-	-

[Table 3-3]

3. Part Names, Operation and Settings

3.3.2 Circular Connectors

- CAN harness (optional) connection
- CAN1 / CAN2 : for multi panels
- CAN3 : PC communication, firmware download, Spare CAN
- ENG. CTRL : External TRIM(Digital Panel out for VCC) and AUX input
- EXT. BUZZER : User connection for external buzzer (External buzzer operating when alarming)



[Fig. 3-4]

No.	CAN1	CAN2	CAN3	ENG. CTRL	EXT. BUZZER
1	+12V Out	+12V Out	+12V Out	VCC(Output)	Battery(+) – Fuse Output
2	GND	GND	GND	TRIM Input	Alarm Out
3	CAN2 H	CAN2 H	CAN1 H	GND	-
4	CAN2 L	CAN2 L	CAN1 L	AUX (+) Input	-
5	Battery(+)	Battery(+)	PC_RXD1	AUX (-) Input	-
6	GND	GND	PC_TXD1	-	-

[Table 3-4]

3.3.3 USB Connector

- USB memory can be inserted for data backup and S/W upgrade.
(Only FAT32 format available)



[Fig. 3-5]

3. Part Names, Operation and Settings

3.4 Fuse and Internal Buzzer

3.4.1 Fuse

- Shut down the power for overcurrent exceeding 5A
- Press the fuse button for 10 seconds to restore fuse operation.

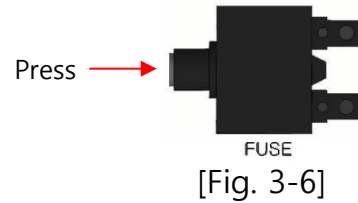

3.4.2 Internal Buzzer

- Generate alarms for sensor problems



3.5 Key Switch

- Key switch is used to boot, turn off the digital panel system and stop the engine.
 - 1) Use the key contained in the product to insert it and rotate to the right by 45~90° (ON) (when the key is ON, the key should remain inserted).
 - 2) When the key is ON, the product will boot and the gauge display will appear in about 17 seconds.
 - 3) Rotate the key to the left by 90° (OFF) to turn it off.
 - When rotating the key to the left (OFF) while ECU running, the display will show a popup message Fig3-10 for Wait To Disconnect. The engine will stop with digital panel power off simultaneously.
 - When the popup window appears, rotate the key to the right (ON) to remove the window and keep the engine on.

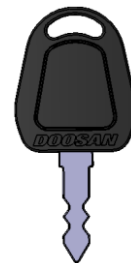

[Fig. 3-8] Key

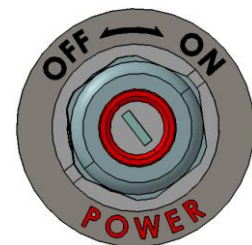

[Fig. 3-9]
Key Switch

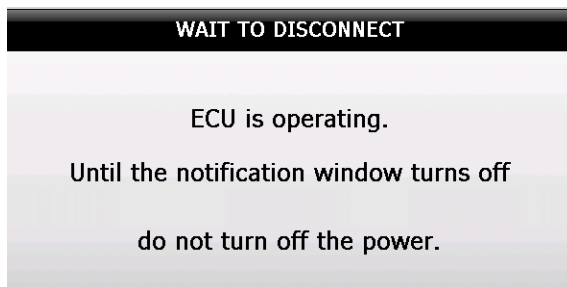

[Fig. 3-10]

3. Part Names, Operation and Settings

3.6 Start/Stop Button

- Start/Stop button is used to start and stop control for the engine.
 - 1) Press the button for more than 1 second while the key is ON, the engine will start (the button LED will flash when pressing the button).
 - 2) Press the button for more than 1 second to stop the engine (Key Off also available for engine stop)
 - ※ You can set the time to 1~3 second for emergency response in Digital Panel Manager.
 - ※ Plastic protection cover label installed.
 - ※ Be careful of strong force because it can be confirmed by LED flashing during pushing operation.

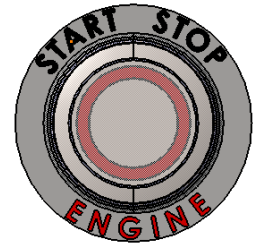

Start Button
[Fig. 3-11]

3.7 Emergency Stop Button

- Emergency Stop Button is used to urgent engine stop for the emergency situation.
 - 1) Press immediately when an emergency situation occurs in the engine run state.
 - Red LED on while pressing
 - 2) Engine RPM drops while depressed.
 - 3) Release the button after the engine is completely stopped.
 - LED off when released
 - ※ If you release the button before stopping the engine, the engine will restart.



Emergency Stop
Button
[Fig. 3-12]

3. Part Names, Operation and Settings

3.8 Function Keys

- Function keys are used to adjust LCD brightness, stop alarming (mute), Close Fault Code Pop-up, Digit, Home and other settings, move to and select menus, and reset the system.

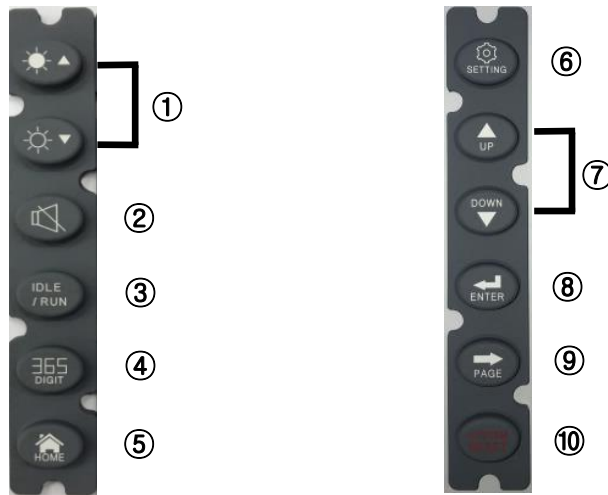

[Fig. 3-13] Function Keys

NO.	Function Key	Action Feature
①	LCD dimmer	<ul style="list-style-type: none"> • LCD brightness adjustable for 5 different levels (when rebooting the system, the previous setting will be maintained).
②	Alarm Mute	<ul style="list-style-type: none"> • Turn off the buzzer sound
③	IDLE / RUN	<ul style="list-style-type: none"> • Change engine running state to IDLE or RUN state
④	Digit On/Off	<ul style="list-style-type: none"> • Default On • Press once : number light will be off • Press once again : number light will be on
⑤	Home	<ul style="list-style-type: none"> • Move to main gauge display. • Move to main display without saving when pressing it in page mode.
⑥	Configuration	<ul style="list-style-type: none"> • Master/Slave setting • ON/OFF setting to start the slave • USB Backup • Convert Korean/English • Set date • Setting Engine Control
⑦	Up/Down	<ul style="list-style-type: none"> • Move the cursor up and down in setting window
⑧	Select	<ul style="list-style-type: none"> • Select menus or functions in the setting window
⑨	Page	<ul style="list-style-type: none"> • Move to spare sensor display (display page 2) / Move to current fault display (display page 3) / Move to event summary display (display page 4)
⑩	System Reboot	<ul style="list-style-type: none"> • Rebooting for system errors (press it for more than 3 seconds to reboot).

[Table 3-5]





3. Part Names, Operation and Settings









3.8.1 Detailed Settings



[Fig. 3-14] Detailed Settings

► Setting Functions and Descriptions

- Product general setting function and engine control setting information.
- Press  button and then use  or  button to move to functions to be changed.
- Press  button to go back to gauge display (changes will be automatically saved).

Digital Panel Setting			
No.	Function	Description	Function Key
1	Master / Slave	• Master/Slave setting for multi panels	
2	USB Back Up	• USB backup for event save files	
3	KOR/ENG	• Convert Korean to English	
4	Date Setup	• Date and time setting	  
5	Slave Engine Start	• ON/OFF setting to start from the slave	
6	Engine Control Setup	• Setting for engine control function • An additional setting window pops up and sets Trim, Aux, Speed Ramping, and Droop.	

[Table 3-6]

3. Part Names, Operation and Settings

Setup Information		
No.	Item	Description
1	RPM	• Current digital TRIM adjustment target RPM
2	TRIM	• Current TRIM setting status information • Off / Analog / Digital mode • When setting analog mode, the user configures devices such as potentiometer
3	AUX	• AUX setting status information • 0~5V / -5~5V mode
4	DROOP	• DROOP setting status information
5	RAMPING	• SPEED RAMPING setting status information

[Table 3-7]

3.8.2 Engine Control Settings

- Set the SPEED TRIM, AUX, SPEED RAMPING and DROOP functions.

- 1) TRIM ENABLE - Selectable digital input or analog input with TRIM function for fine tuning of engine speed (Select with the ENTER button and press the SETTING button to set).
- 2) TRIM RPM - Input of the \pm change of RPM when digital input is selected
 - ⇒ Set to "DIGITAL" in the TRIM ENABLE setting window. If TRIM RPM = 10, output as 1810 in case of 1800 target rpm.
- 3) TRIM GAIN – Set the maximum amount of change when TRIM is potentiometer analog input
 - ⇒ Set as "ANALOG" in the TRIM ENABLE setting window. If TRIM GAIN = $\pm 5.0\%$, it can be set within $\pm 5.0\%$ of target rpm 1800, that is, $\pm 90\text{RPM}$.
 - ⇒ If the input voltage from the potentiometer is 0V, it outputs 1710rpm, if it is 2.5V, it outputs 1800rpm, and if it is 5V, it outputs 1890rpm.
 - ⇒ Refer to the ENG. CTRL pinmap above [Table3-4] and connect the external potentiometer.



3. Part Names, Operation and Settings

- 4) AUX ENABLE - In parallel operation, an input signal from an external load sharer or synchronization device is used, and from -5~5V / 0~5V two modes can be selected.
 - ⇒ Refer to the ENG. CTRL pinmap above [Table 3-4] and connect the external potentiometer.
- 5) AUX SPEED - When setting AUX, setting the amount of change in speed for stable engine operation
 - ⇒ When setting -5V ~ 5V mode, if AUX SPEED = ±10RPM, external input -5V is 1790RPM, 0V is 1800RPM, +5V is 1810RPM output
 - ⇒ When setting 0V ~ 5V mode, if AUX SPEED = ±10RPM, external input 0V is 1790RPM, +5V is 1810RPM output
- 6) SPEED RAMPING – Time to stabilize when speed is raised by engine run or when lowered by idle
 - ⇒ ex) In case of setting 10, it takes 10 seconds from 600rpm to 1800rpm or 1800rpm to 600rpm
- 7) DROOP ENABLE - Set to use the DROOP function
- 8) DROOP GAIN – The DROOP gain should not exceed the maximum 8%, and the maximum DROOP rpm range is set by the GAIN setting.
 - ⇒ ex) When DROOP GAIN is 5% and TARGET RPM is 1800, the displacement of DROOP RPM is ±90RPM

When the current torque is less than the No Load Torque set in the setting window, it is controlled by 1890RPM, which adds 90RPM of DROOP RPM to the TARGET RPM 1800.

Engine Control Setting	
TRIM ENABLE	OFF
TRIM RPM	0 RPM
TRIM GAIN	±0.0%
AUX ENABLE	OFF
AUX SPEED	±0 RPM
SPEED RAMPING	5 SEC
DROOP ENABLE	OFF
DROOP GAIN	0.7%
F-LOAD TORQUE	0Nm
N-LOAD TORQUE	0Nm

[Fig. 3-15] Gauge Display

※ When the current torque is greater than or equal to the maximum torque, normally, the maximum torque is default 250, so the current torque cannot exceed the maximum torque, but the formula in case of exceeding the range is

$$\text{Set RPM} = 1800, \quad \text{target RPM} = \text{Set RPM} - \frac{(\text{Present Engine Torque} - \text{Max60Hz Torque}) \times \text{Droop RPM}}{\text{Max60Hz Torque} - \text{NO Load Torque}}$$

If the current torque value is less than or equal to the maximum torque value, the formula is

$$\text{Set RPM} = 1800, \quad \text{target RPM} = \text{Set RPM} + \frac{(\text{Max60Hz Torque} - \text{Present Engine Torque}) \times \text{Droop RPM}}{\text{Max60Hz Torque} - \text{NO Load Torque}}$$

3. Part Names, Operation and Settings

3.9 Display Structure

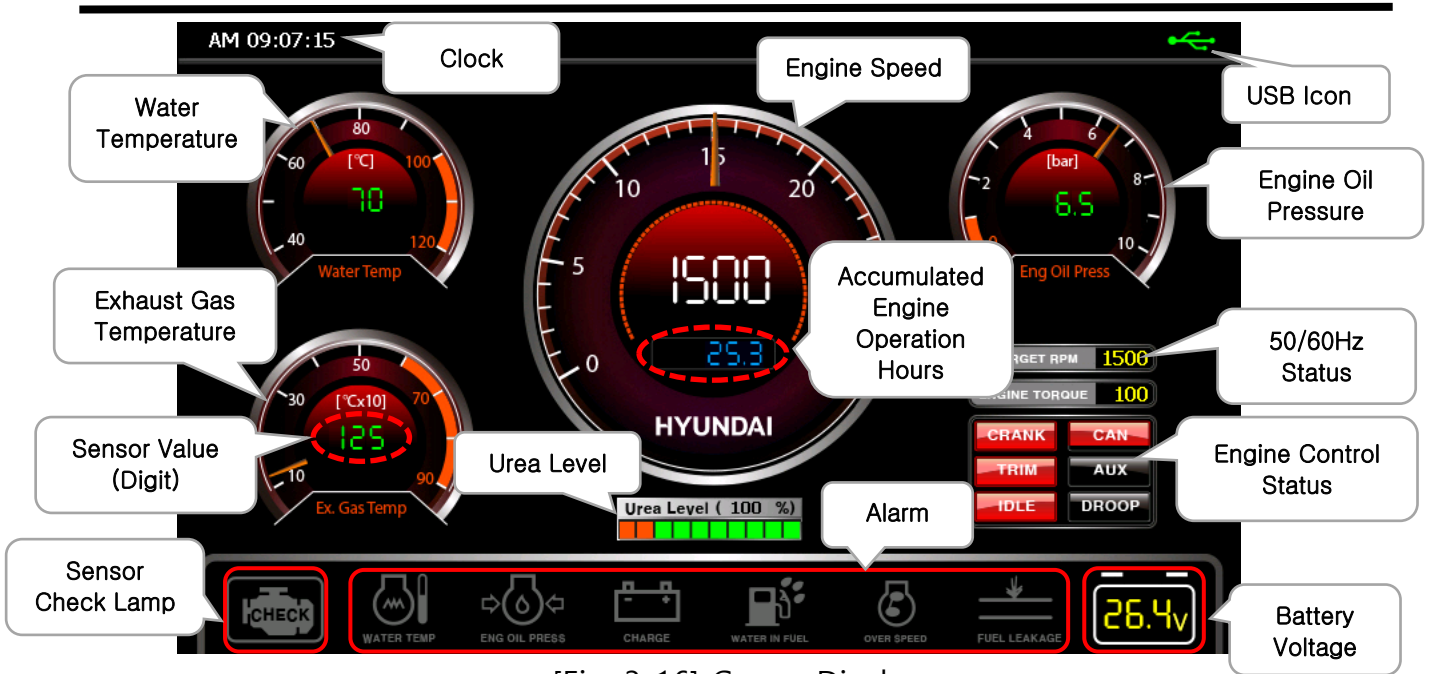

[Fig. 3-16] Gauge Display

- Gauge display shows various gauge data including pick up (RPM) sensor, coolant temperature, exhaust gas temperature, engine oil pressure and Urea Level(enable/disable based on engine specification) and Engine rpm control function according to load.
- It also includes Current Clock, battery voltage indication, accumulated engine operation hours, Target RPM Status, Engine Control Status, coolant temperature, engine oil pressure, charging, fuel leakage and overspeed alarms.

3.9.1 Engine Speed (Tachometer)

- It shows engine RPM in gauge and digital values and counts accumulated engine operation hours.

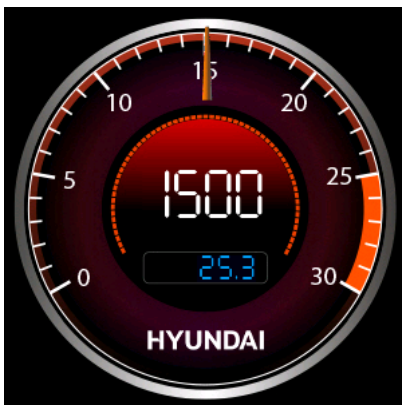

[Fig. 3-17]

Engine Speed Gauge

- 1) It shows the RPM indicated by the gauge hand in digital values (White) for better accuracy (however, it is available off by the 'DIGIT' button).
- 2) It shows Fault Code P0219 when engine speed is over.
 - ➔ Engine overspeed detection error
- 3) It shows accumulated engine operation hours by hour unit (engine speed of 1RPM or faster will be counted and the function is always on)

3. Part Names, Operation and Settings

3.9.2 Engine Water Temperature

- It shows the coolant temperature in gauge and digital values.

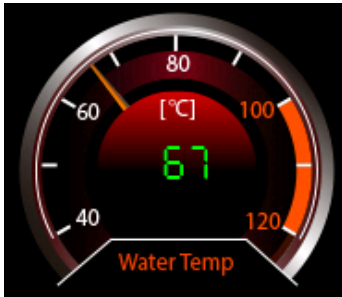

[Fig. 3-18]

Engine Water Temperature Gauge

- 1) It shows the temperature indicated by the gauge hand in digital values (green) for better accuracy (however, it is available off by the 'DIGIT' button).
- 2) Fault Code Occurred P2185 When Coolant High Temperature Detected.
➔ High coolant temperature error Alarm
- 3) It activates alarm and warning beep when under alarm conditions from ECU.

3.9.3 Engine Oil Pressure

- It shows engine oil pressure in gauge and digital values.

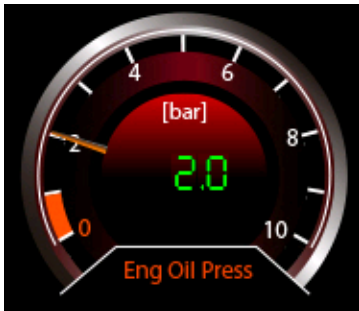

[Fig. 3-19]

Engine Oil Pressure Gauge

- 1) It shows the pressure indicated by the gauge hand in digital values (green) for better accuracy (however, it is available off by the 'DIGIT' button).
- 2) It activates alarm and warning beep when the pressure is 1bar or lower.
- 3) When the pressure is 0.5bar or lower, the engine will stop (detects in 10 seconds).
- 4) It shows Fault Code P1521 when engine speed is over.
➔ Low oil pressure error

3.9.4 Exhaust Gas Temperature

- It shows exhaust gas temperature in gauge and digital values.



[Fig. 3-20]

Exhaust Gas Temperature

- 1) It shows the temperature indicated by the gauge hand in digital values (green) for better accuracy (however, it is available off by the 'DIGIT' button).
- 2) Warning light operates when the temperature exceeds 600°C in the starting state.

3. Part Names, Operation and Settings

3.9.5 Battery Voltage

- It shows battery voltage to indicate its conditions.



[Fig. 3-21] Battery Voltage

- 1) It will show in yellow for voltage of 24V or higher or red for voltage lower than 24V
- 2) It activates warning beep when the low voltage with fault code P0562.
- 3) Low battery voltage error

3.9.6 Sensor Check Lamp

- When a fault code occurs, the sensor check lamp flashes and changes to the lighting state when the alarm is muted.



[Fig. 3-22] Check Sensor Lamp

- 1) When the check sensor light is on, it will show in red.

3.9.7 Engine Alarms

- The alarm will be activated with buzzer beeping when problems for coolant temperature, engine oil pressure, charging, water in fuel, fuel leakage and over speed are detected.

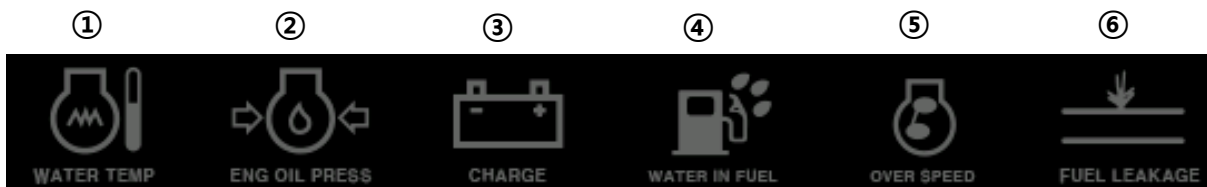

[Fig. 3-23] Engine Alarms

※ How to deactivate the engine alarm

- Press SYSTEM RESET button on the right for 3 seconds, the system will reboot and the alarm will be deactivated (rebooting is available while the ship navigates without causing problems).

3. Part Names, Operation and Settings

NO.	Alarm	Action Feature
①	Water temperature	• Alarm (buzzer) will be activated when the temperature is 100°C or higher
②	Engine oil pressure	• Alarm (buzzer) will be activated on when the pressure is 1 bar or lower
③	Charging	• Alarm (buzzer) will be activated when the battery voltage is lower than 27V
④	Water In Fuel	• Alarm (buzzer) will be activated when the WIF switch is on
⑤	Engine over speed	• Alarm (buzzer) will be activated when the speed exceeds 110% of the rate speed
⑥	Fuel leakage	• Alarm (buzzer) will be activated when oil leak occurs (default setting is 'disabled')

[Table 3-8] Alarm Features

3.9.8 Engine Stop

- Engine stop when the ECU controls the engine directly and under the following conditions

- 1) When the over speed exceeds **110%** of the rate speed
- 2) When the coolant temperature exceeds **105°C**
- 3) When the oil pressure is **0.5bar** or lower
- 4) When fuel leakage occurs
- 5) When the engine is normally stopped, key-off from the panel or other ECU is determined to be necessary

3. Part Names, Operation and Settings

3.10 Sensor etc.

- It identifies the status of the other sensors, product S/N, ECU MAP VERSION and GUI/FIRMWARE version. To see this page, press  button from main page.



[Fig. 3-24] Other Sensors and S/W information

Item	Condition
Max. Torque	• Maximum torque of the engine, expressed in Nm
Eng Torque	• Current torque of the engine, expressed in Nm
Boost Temp.	• booster temperature, marked above -273°C
Eng Oil Temp.	• Engine oil temperature, marked above -40°C
Eng Fuel Temp.	• Engine fuel temperature, marked above -40°C
Intake Temp.	• Intake manifold temperature, marked above -40°C
Inst. Fuel	• Instant fuel consumption rate, expressed in L/H
Intake Press.	• Booster pressure, expressed in bar
Reductant Quality	• Urea concentration, expressed in %

[Table 3-9] Sensors Conditions

3. Part Names, Operation and Settings

3.11 Fault Code Information

- ECU detects whether there is an abnormality in the engine while the engine is running, and when a fault condition is met, the fault code is transmitted through CAN communication, and the code is received from the digital panel, and the fault code and fault details are output to the monitor as shown in Figure 3-25.
- Figure 3-25 displays all faults received in real time.
- The fault code alarm window in Figure 3-26 appears on the screen when a fault code occurs, regardless of which page the user is working on.

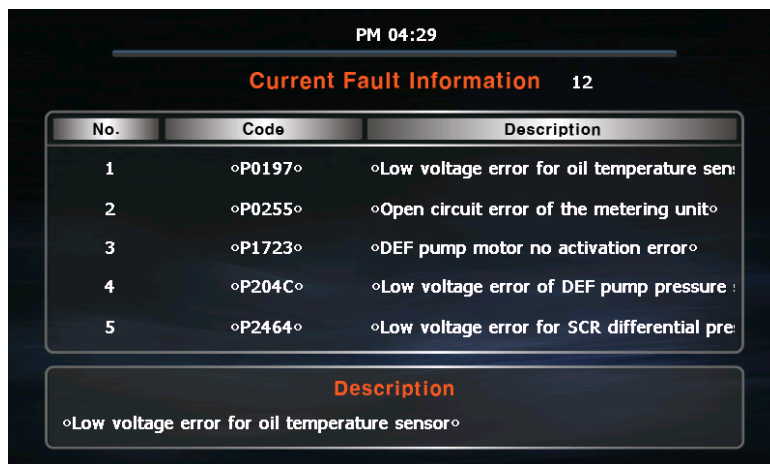

PM 04:29

Current Fault Information 12

No.	Code	Description
1	◦P0197◦	◦Low voltage error for oil temperature sensor◦
2	◦P0255◦	◦Open circuit error of the metering unit◦
3	◦P1723◦	◦DEF pump motor no activation error◦
4	◦P204C◦	◦Low voltage error of DEF pump pressure sensor◦
5	◦P2464◦	◦Low voltage error for SCR differential pressure sensor◦

Description

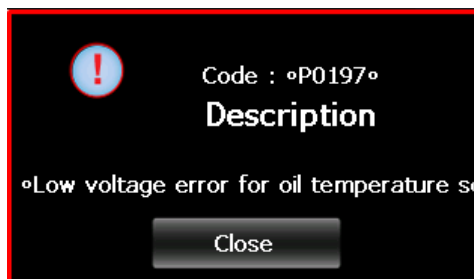

◦Low voltage error for oil temperature sensor◦

[Fig. 3-25] Fault Code List



[Fig. 3-26] Fault Code pop-up window

► How to close the fault code pop-up window

- 1) Figure 3-26 When pop-up, one pop-up window closes each time the  button is pressed.
- 2) Press and hold the  button for more than 3 seconds to close the entire pop-up window.

3. Part Names, Operation and Settings

3.12 Event Summary

- It shows the numbers of normal operations, normal stops, emergency stops and sensor errors together with dates of recent errors.
- Press  button in spare sensor page to move to event summary page.

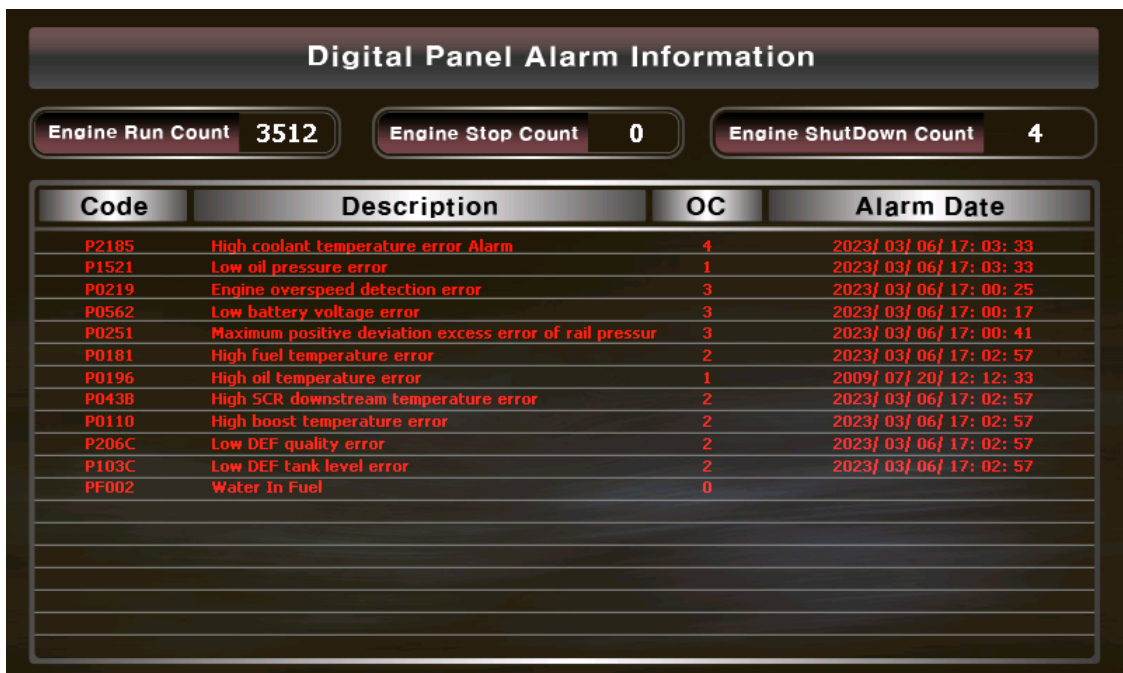

[Fig. 3-27] Event Summary Screen

Event List			
P2185	High coolant temperature error Alarm	P0196	High oil temperature error
P1521	Low oil pressure error	P043B	High SCR downstream temperature error
P0219	Engine overspeed detection error	P0110	High boost temperature error
P0562	Low battery voltage error	P206C	Low DEF quality error
P0251	Maximum positive deviation excess error of rail pressure	P103C	Low DEF tank level error
P0181	High fuel temperature error	PF002	Water In Fuel

[Table 3-10] Event List

3. Part Names, Operation and Settings

3.13 System Booting and Functional Check

- You can check whether the product is properly installed or not.

▶ Normal System Booting

- 1) Insert the key into the key switch and rotate it to the right (ON).
- 2) HYUNDAI logo will appear for 15 seconds while the system is booting (refer to the image).
 - ※ If the logo does not appear after rotating the key,
 - Rotate it to the left (OFF) and then to the right (ON) again
 - Check the harness connection at the back of the panel
 - Check whether the battery is discharged
- 3) The gauge display will appear after normal booting.
 - Gauge: check whether each gauge hand is within the normal range and 'ERROR' or '-----' is displayed on the screen.
 - ※ Where 'ERROR' or '-----' is displayed on the screen
 - Check the harness connection
 - Function keys: check whether each function key is active on the screen by pressing them.
 - Alarm: check whether the alarm is turned on.
 - Battery: Check whether the battery is ok.
- 4) Where the initial gauge screen is normal, press START button for 1 second to start the engine (the time can be set to 1~3 second. Refer to Digital Panel Manager).
- 5) Check whether the operation is in normal RPM (initial operation in 400RPM or faster with the oil pressure of 1bar or higher) and whether is turned on.

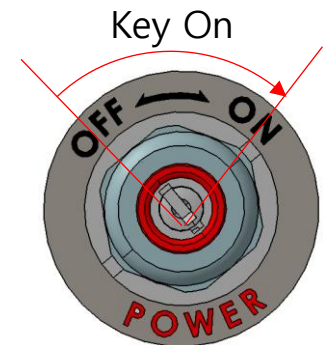

[Fig. 3-28] Key Switch



[Fig. 3-29] Booting Logo

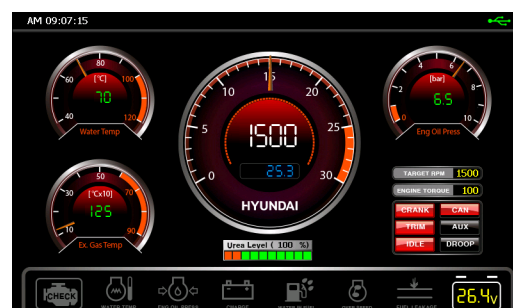

[Fig. 3-30] Gauge Display

4. Multi Panel Structure

4.1 Multi Panel

- Panels can be installed up to 4 units except Master in the ship and you can check the ship conditions and control those panels at any places of installation.
- However, note that the battery voltage drops as the harness length increases.

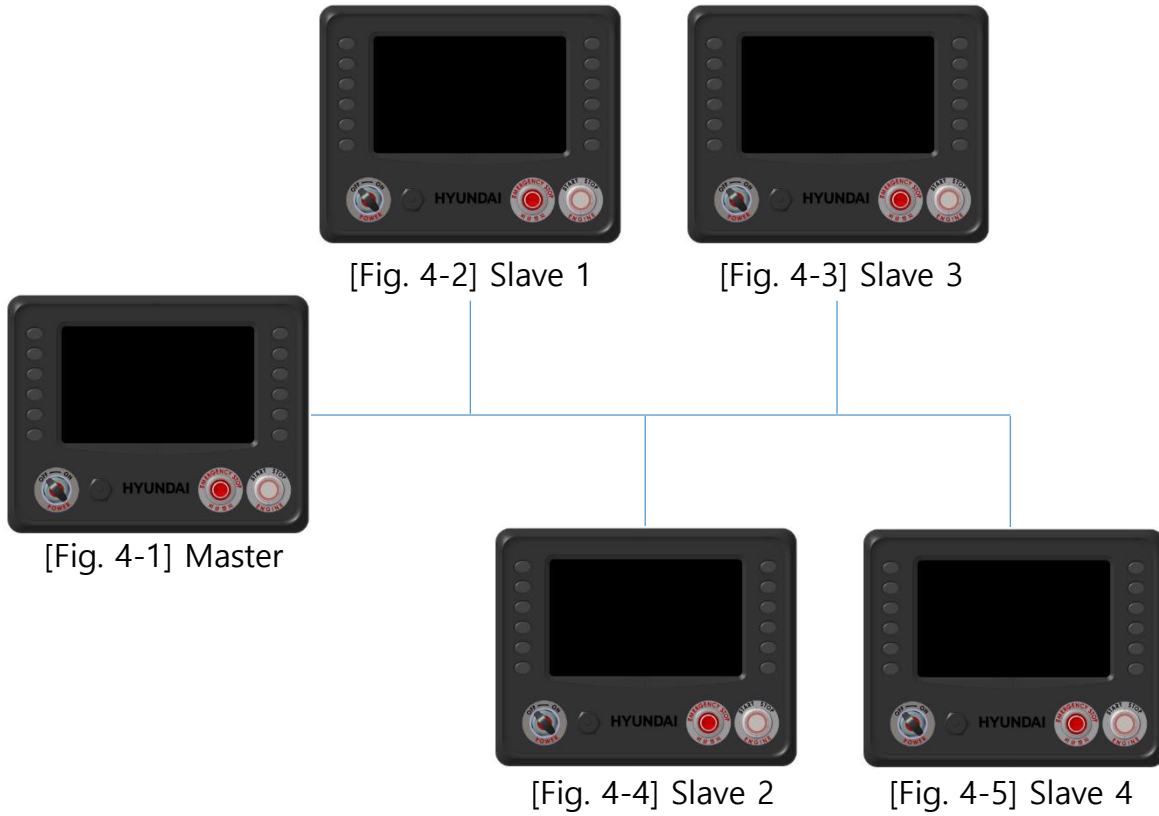

4. Multi Panel Structure

4.2 How to Install Multi Panels

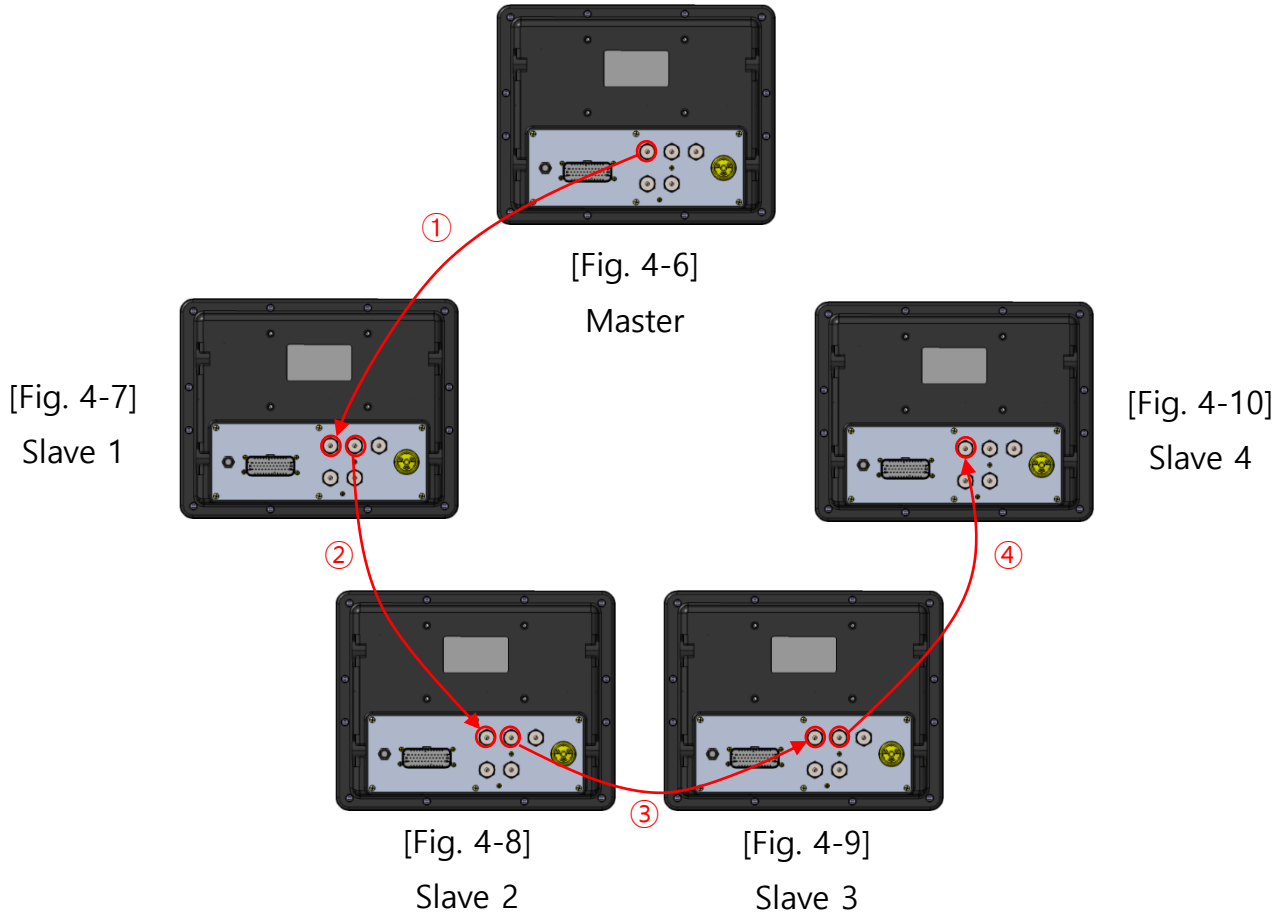

※ In order to install multi panels, all the necessary cables should be ready in advance (use the cables with specification recommended by HYUNDAI).

(1) Connect the CAN1 terminal of the Master panel and the CAN1 terminal of the Slave 1 panel as shown in ① (2 panels).

- Master and Slave 1 connection completed

(2) Connect Slave 1 (CAN2) and Slave 2 (CAN1) as shown in ② while maintaining connection as described in ① (3 panels).

- Master, Slave 1 and Slave 2 connection completed

(3) Connect Slave 2 (CAN2) and Slave 3 (CAN1) as shown in ③ while maintaining connection as described in ② (4 panels).





- Master, Slave 1, Slave 2 and Slave 3 connection completed

(4) Connect Slave 3 (CAN2) and Slave 4 (CAN1) as shown in ④ while maintaining connection as described in ③ (5 panels)

- Master, Slave 1, Slave 2, Slave 3 and Slave 4 connection completed

4. Multi Panel Structure

4.3 Multi Panel Settings

- (1) Press  button of the panel to be configured as Slave.
- (2) Move to ① when the setting screen appears (use  or  button to move).
- (3) Press  button to switch configuration between Master and Slave.
- (4) Configure the Master panel as described above.

※ Notes

- Master mode is available for one panel only and Slave mode is up to 2 units recommended.
- If the length of the harness between the Master and the Slave is more than 30m, the battery voltage drop may occur more than 1V, so check it.
- You can permit Slaves to start the engine with Master panel only. Where you enable Slave Engine Start setting, all Slave panels will be able to start the engine.

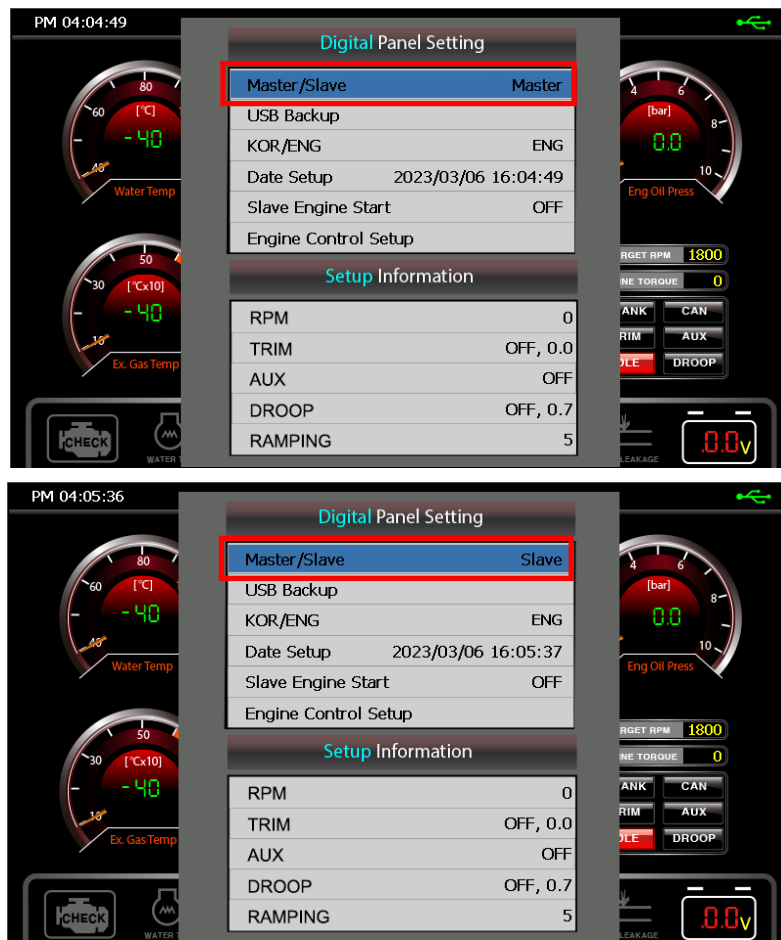

[Fig. 4-11] Multi Panel Setting Window

5. Maintenance

5.1 Maintenance

- To maintain the performance of the device, regular maintenance is required.
 1. Use soft cloth to clean the LCD without damaging it.
 - 1) Clean the LCD after turning the power off.
 - 2) Do not use cleaners with acids or ammonia.
 - 3) Do not use neutral detergents to remove oil stains.
 - 4) Use cloth slightly wet in clean water to remove salt residuals or dust particles for natural drying. If there remain stains, clean them with soft cloth (microfibers) once again.
 2. Check whether the connectors or harnesses at the back of the device are properly connected or whether they have dust or other foreign substances.
 3. Check whether cables are damaged.
 4. Request for checking when the software needs upgrade as follows:
 - When the manufacturer releases official software for performance improvements

5.2 Troubleshooting

- It describes possible measures for users to resolve problems while using the device.
 1. The device is not turned on.
 - 1) Check whether harness cables at the back of the product are properly connected.
 - 2) Where harness cables have too much dust or moisture, remove them and clean the dust or moisture. Connect them once again after a while.
 - 3) Check whether the fuse button at the back of the product is pulled out.
 - 4) Check whether the battery is discharged.
 2. You can see lines or shaking on the screen.
 - 1) Reboot the product.
 - 2) As the LCD is connected inside the product, do not disassemble it and contact the service team.
 3. You can see alarm or hear warning beeps at the bottom of the product screen.
 - 1) Check where the alarm occurs and then take measures as necessary (if you need to confirm which alarm occurs, refer to Page 22 of this manual).
 4. You cannot control buttons.
 - 1) Check whether there are foreign substances at the panel buttons.
 - 2) As the button connecting parts may be damaged, do not disassemble the product and contact the service team.

6. Warranty and A/S Service

6.1 Warranty

- As this manual contains important contents related to safety, use and maintenance of the product. So please read this manual carefully and then use the product in a proper manner.

Those who are not familiar with the product should keep this manual close to it.

We are not responsible for human injuries or property damages caused by the following reasons:

- Where you use the product for purposes other than the ones described in this manual
- Where you alter the product or its components at discretion
- Where you disassemble the product at discretion to resolve problems
- Where you use accessories or parts not supplied or recommended by us
- ※ Where you use accessories or parts manufactured by other companies, please contact our service center to check their compatibility.

6.2 A/S Service Information

- When you request A/S service, please let us know the model name, breakdown conditions and your contact information.
- Please ask the seller.

User Manual for 8 Inch Digital Panel for Electronic Marine Auxiliary Engine

Ver.1.0



HYUNDAI

► Contents

1. General Information

1.1	Product Information	3
1.2	Components and Optional Accessories	3
1.3	Product Specification	4

2. Product Installation

2.1	Cautions	5
2.2	Desk Mounting Type	6
2.3	Flush Mounting Type	7

3. Part Names, Operation and Settings

3.1	Front Side	8
3.2	Back Side	8
3.3	External Connection Terminals	9
3.3.1	DGP 23Pin Main Connector	9
3.3.2	Circular Interface Connector	10
3.3.3	USB Connector	10
3.4	Internal Buzzer	11
3.5	Key Switch	11
3.6	Emergency Start Button	12
3.7	Emergency Stop Button	12
3.8	Function Keys	13
3.8.1	Detailed User Settings	14
3.8.2	Detailed Generator Settings	15
3.9	Display Structure	17
3.9.1	Engine RPM	18
3.9.2	Engine Cooling Water Temperature	18
3.9.3	Engine Oil Pressure	19
3.9.4	Exhaust Gas Temperature	19
3.9.5	Exhaust Gas Temperature LH	19
3.9.6	Exhaust Gas Temperature RH	20
3.9.7	Urea Level	20
3.9.8	Urea Level	20
3.9.9	Water In Fuel	21
3.9.10	Check Sensor Light	21

► Contents

3.9.11	Battery Voltage	-----	21
3.9.12	TRIM, DROOP/AUX	-----	21
3.9.13	Engine Alarm	-----	22
3.9.14	Engine Stop	-----	23
3.10	Spare Status	-----	23
3.11	Current Fault Information Page	-----	25
3.12	Alarm Page	-----	26
3.13	System Booting and Functional Check	-----	28
4. Multi Panel Structure			
4.1	Multi Panel	-----	29
4.2	How to Install Multi Panel	-----	30
4.3	Multi Panel Settings	-----	31
5. Maintenance			
5.1	Maintenance	-----	33
5.2	Troubleshooting	-----	33
6. Warranty and A/S Service			
6.1	Warranty	-----	34
6.2	A/S Service Information	-----	34

1. General Information



1.1 Product Information

This product is a digital panel for electronic auxiliary engine displays and can be applied to various small marine engines. The DGP model is designed to be robust for marine environments and is equipped with digital visualization to clearly monitor engine control and status information. It provides information through graphical analog gauges and digital displays, aiming to enhance user convenience.

1.2 Components and Optional Accessories

- Refer to Table 1-1 below for product components
- Reference
DGP: Digital Gauge Panel

Components

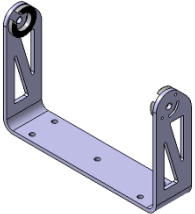
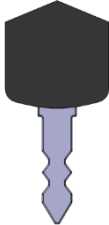
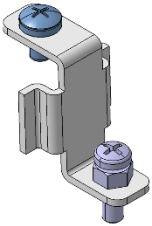
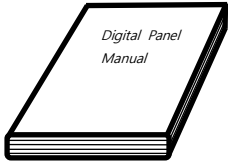
NO	Components	Component Name	NO	Components	Component Name
1		DGP	4		Desk Mounting Type Parts 1set
2		Desk Mounting Type Bracket	5		Key 2EA
3		Flush Mounting Type Bracket 4EA	6		User Manual

[Table 1-1]

1. General Information

1.3 Product Specification

- Refer to Table 1-2 below for the hardware specifications of the digital panel for this electronic engine

Digital Gauge panel product Specification

No.	Item	Remark
1	Microprocessor	<ul style="list-style-type: none">• NXP4330Q / S32K144
2	Software	<ul style="list-style-type: none">• Linux OS GUI + F/W
3	Display	<ul style="list-style-type: none">• 8" Color TFT LCD• 1280 * 720(Pixel)• 16 : 9
4	Flash Memory	<ul style="list-style-type: none">• 4GB(eMMC)
5	Ram	<ul style="list-style-type: none">• 1GB
6	Operating Voltage	<ul style="list-style-type: none">• 9V ~ 30V DC
7	USB	<ul style="list-style-type: none">• USB 2.0 1Port
8	Operating Temperature	<ul style="list-style-type: none">• - 20°C ~ 70°C
9	Operating Temperature	<ul style="list-style-type: none">• Piezo Buzzer 98dB
10	Internal Buzzer	<ul style="list-style-type: none">• SAE J1939 CAN communication• RS232
11	Communication	<ul style="list-style-type: none">• W 287 x H 245.8 x D 107.1(DGP)

[Table 1-2]

2. Product Installation

2.1 Cautions

- Unskilled personnel should read this manual before use.
- Do not use or keep the product close to combustible sprays or inflammables.
- Use soft and dry cloth to clean the panel LCD.
- Turn off the product, pull out the harness cable and then contact our service center when you see smoke from the panel or have strange smells.
- When you see an alarm on, you always need to check the product before operation.
- Do not disassemble the product cover at discretion (warranty does not cover unauthorized disassembly).
- Excessive impact may damage the display although a reinforced display is used.
- Use connectors matching each other when connecting them to the back of the product.
- Do not contact or remove connectors while the power is on. It may cause electric shock or lead to malfunction.
- Do not exercise excessive force when rotating to ON/OFF with the key inserted in.
- Do not use the product with wet hands.
- Put protective caps on back side connectors when they are not in use.

2. Product Installation

2.2 Desk Mounting Type

- ※ Desk Mounting Types are installed in the steering or engine room by using desk mounting brackets delivered with the product.
- ※ Mounting Hole Spec: M6 bolt

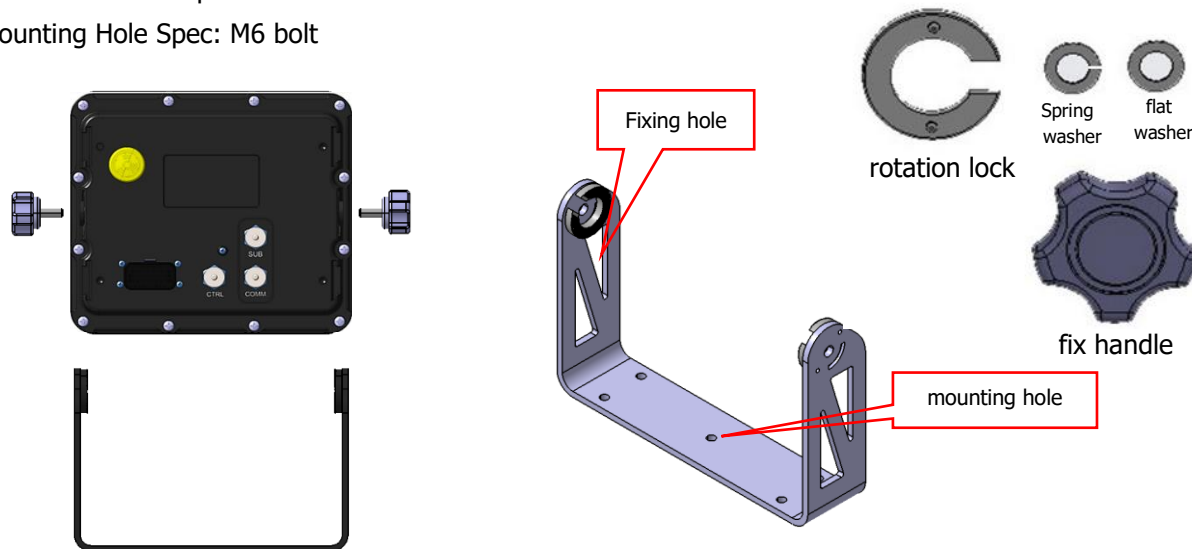

[Fig. 2-1] Desk Mounting Type Diagram

► Installing Desk Mounting Type digital panel

- ① Check if there is cable wiring available in the wheelhouse or engine room.
- ② Fix the bracket using mounting hole of the product at the position where the cable wiring reaches.
- ③ Place the product inside the bracket connected with the rotation lock to connect it with the rotation lock.
- ④ Connect it with the fix handle to the direction indicated by an arrow and adjust the viewing angle of the LCD

※ Where there are things to which the product can be fixed, use spare holes with the bolt or other accessories.

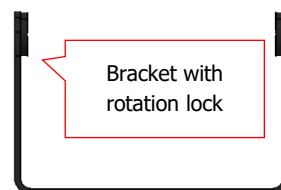

[Fig. 2-2]

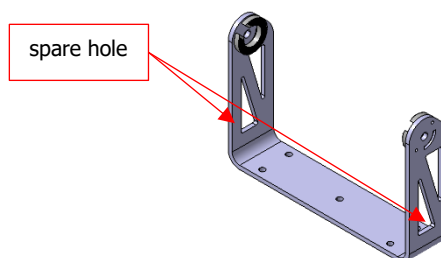
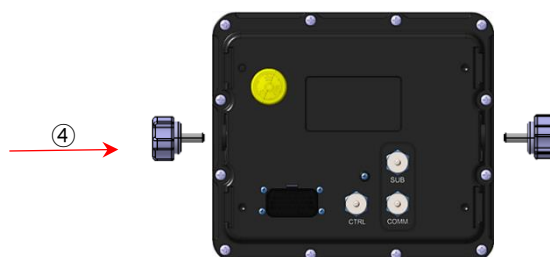

[Fig. 2-3]

2. Product Installation

2.3 Flush Mounting Type

- Flush Mounting types are installed in a steering or engine room by using optional mounting brackets (2pcs).

※ Bolt Spec: ① M6 X 10L ② M6 X 20L

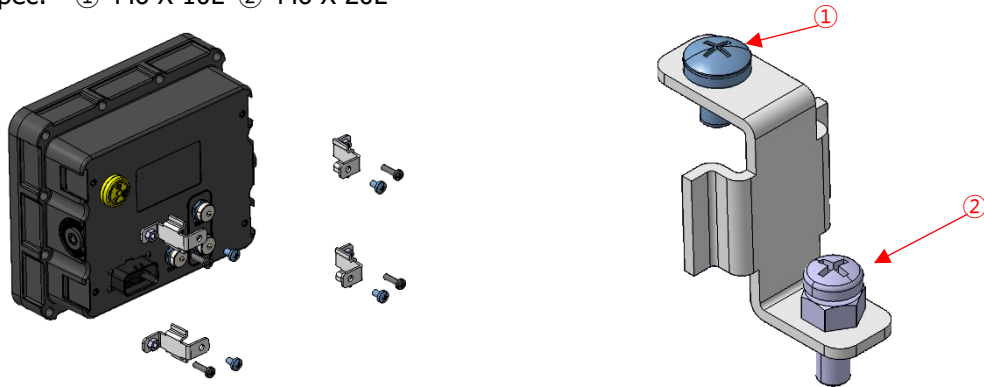

[Fig. 2-4] Flush Mounting Type Diagram

► Installing Flush Mounting Type digital panel

- ① Check the harness is wired in the steering or engine room.
- ② As shown in [Fig. 2-5], fix the mounting brackets to both sides of the panel.
- ③ Check the location within reach of the harness wiring and the mounting location and then mount the panel using proper bolts.
- ④ Finish gaps between the product and the structure depending on the mounting conditions and connect the engine harness (you may connect the engine harness first depending on conditions)

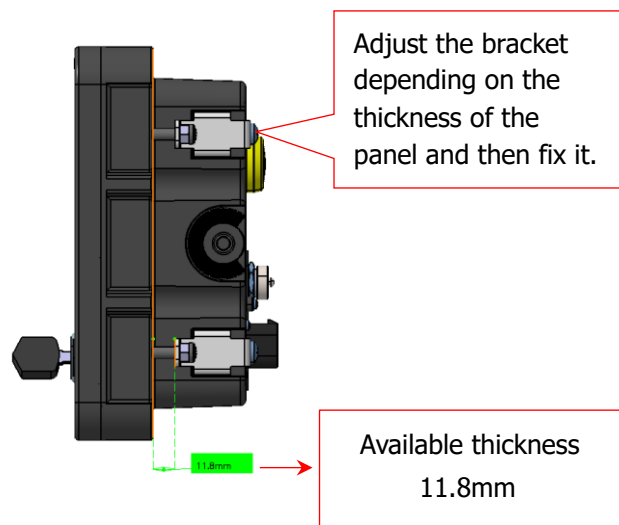

[Fig. 2-5]

3. Part Names, Operation and Settings

3.1 Front Side



[Fig. 3-1]

No.	Name	Reference
①	LCD	-
②	Function Keys	13 Page
③	Key Switch	11 Page
④	USB	10 Page
⑤	Emergency Start Switch	12 Page
⑥	Emergency Stop Switch	12 Page
⑦	IDLE Key	13 Page
⑧	RUN Key	13 Page

[Table 3-1]

3.2 Back Side

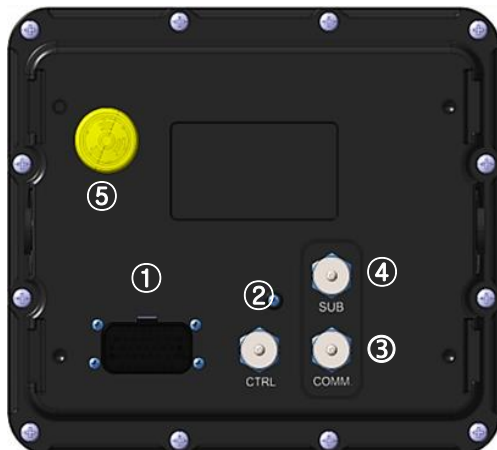

[Fig. 3-2]

No.	Name	Reference
①	Main Connector	9 Page
②	Engine Control (External Buzzer and Function for Ship Generator)	10 Page
③	COMM. (CAN / RS-232)	10 Page
④	SUB	10 Page
⑤	Internal Buzzer	11 Page

[Table 3-2]

3. Part Names, Operation and Settings

3.3 External Connection Terminals

- Input/output connector connecting DGP and ECU
- Input/output connector for various control signals including sensors between ECU and engine

3.3.1 DGP 23Pin Main Connector

- Interface connector for receiving power and vessel operation information from ECU and transmitting and receiving CAN signals

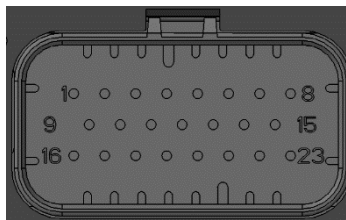

[Fig. 3-3]

No.	Pin Description	Notes	No.	Pin Description	Notes
1	BATT IN	-	13	PC RXD1	-
2	BATT IN	-	14	PC TXD1	-
3	Power GND	-	15	Alternator IN	-
4	Power GND	-	16	Wait to Disconnect Signal	
5	Key ON	-	17	Wait to Disconnect Common	
6	STARTER Signal	-	18	-	
7	Emergency Switch Power	-	19	-	
8	Emergency Switch Signal	-	20	Fuel Leakage Switch	
9	CAN 2(J1939) High	-	21	GND Sensor	
10	CAN 2(J1939) Low	-	22	Water IN Fuel Sensor	
11	CAN 1(UDS) High	Option	23	GND Sensor	
12	CAN 1(UDS) Low		-	-	

[Table 3-3]

3. Part Names, Operation and Settings

3.3.2 Circular Interface Connector

- CTRL : Buzzer output connector for external buzzer connection
- COMM. : Multi-panel[OUT], communication connector for power and CAN communication
- SUB : Multi-panel[IN], communication connector for power and CAN communication

No.	CTRL	COMM.	SUB
1	BUZZ BATT	Key-ON	Key-ON
2	BUZZ OUT	BATT IN	BATT IN
3	VCC	CAN1 H	CAN1 H
4	RPM_TRIM	CAN1 L	CAN1 L
5	GND	CAN2 H	CAN2 H
6	ISO_AUX+	CAN2 L	CAN2 L
7	ISO_AUX-	GND	GND
8	GND	-	-

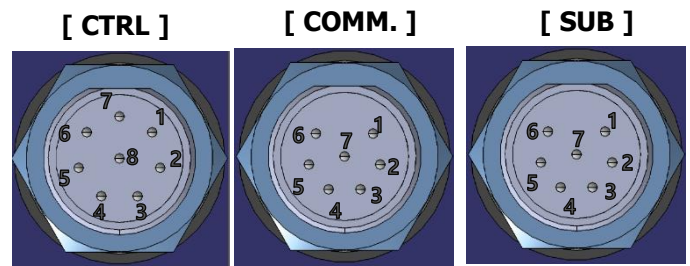

[Fig. 3-4]

[Table 3-4]

3.3.3 USB Connector

- When backing up driving record data and upgrading software, insert a USB memory (FAT32 format is used)

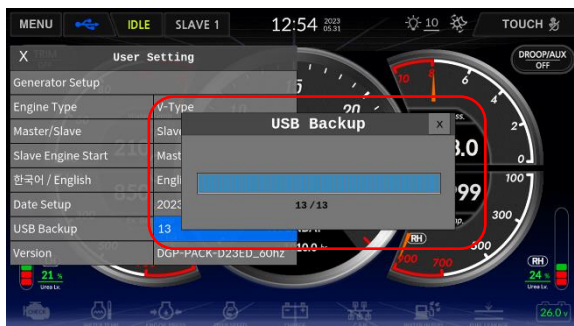

[Fig. 3-5-1]



[Fig. 3-5-2]

3. Part Names, Operation and Settings

3.4 Internal Buzzer

- Buzzer sound when an alarm occurs due to engine abnormality.
- It operates at 98dB, and an external large-capacity buzzer can be additionally installed.



[Fig. 3-6]

3.5 Key Switch

- Digital panel system boot, engine start, and engine stop functions.
 - 1) After inserting the key included in the product in the key switch and turning it to the position of 45° to the right (ACC), the product is booted.
 - 2) Engine starts at the position of 90° turn (ON) and it returns to 45° position (If the key is in the ON state, keep the key lock state)
 - 3) When ACC is ON, the product boots within 5 seconds and the gauge screen is output after the introduction screen.
 - 4) Turn the key 45° to the left (OFF) when the engine is stopped
 - When the key is rotated to the left (OFF) position in Engine operation, in case, the panel power is turned off and the ECU is still operational, the "System Power Shutdown" alarm message window will pop up, and the engine will be shut down as shown in [Fig. 3-9].
 - When the pop-up window appears, rotate the key to the right (ON) position, then the pop-up window will disappear, and the engine will remain in the ON state.

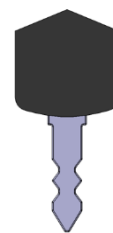

Key

[Fig. 3-7]



Key Switch

[Fig. 3-8]

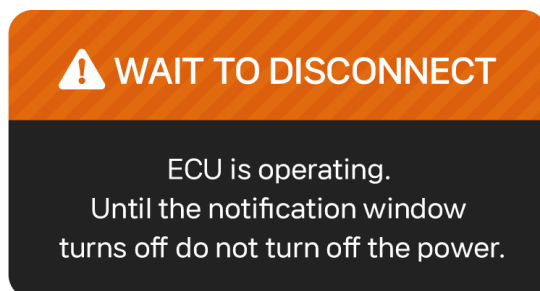

[Fig. 3-9]

3. Part Names, Operation and Settings

3.6 Emergency Start Button

- Used to force the engine to start in an emergency situation.
 - 1) In the OFF state of the key, rotate the key to ON while pressing it with an available device for the buttonhole.
- ※ Application of safety accident prevention function
- ※ Hole Size : Ø7

- ※ It should be used only in emergency situations and product life may be affected when used.

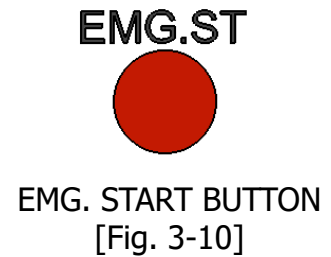

3.7 Emergency Stop Button

- Used to stop the engine in an emergency situation.
 - 1) Press immediately in case of emergency in engine running.
 - 2) When the emergency stop is activated, and audible alarm will sound, and the emergency stop pop up window [Fig. 3-12] will be displayed on the LCD screen, while the engine RPM decreases.
 - 3) The indicator will display the Shutdown icon [Fig. 3-13]
 - 4) Emergency stop status is not lifted until Key is off.
- ※ If the button is released within a short period of time, the engine may not be stopped.
- ※ It should be used only in emergency situations and product life may be affected when used.

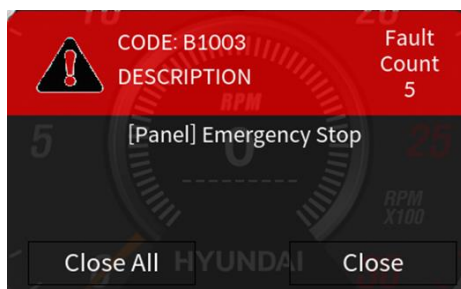

3. Part Names, Operation and Settings

3.8 Function Keys

- Functions such as panel setting, alarm stop, menu movement, and selection.
- The indicator will display the IDLE icon and RUN icon [Fig. 3-15][Fig. 3-16] to indicate the operational state when the IDLE and RUN buttons are pressed.

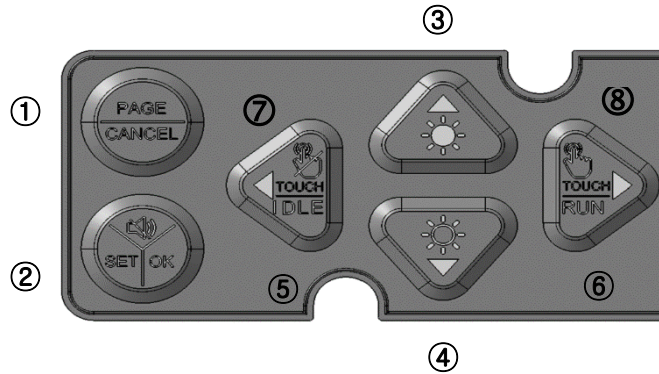

[Fig. 3-14] Function Keys

NO.	Function	Action Characteristics
①	Page	• switch page / cancel
②	Ok	• Enter setting, save setting value
③	Up	• Cursor movement (up), setting value change (increase), screen brightness increase
④	Down	• Cursor movement (down), setting value change (decrease), screen brightness decrease
⑤	Left	• Cursor movement (left), Lock LCD touch function
⑥	Right	• Cursor movement (right), unlock LCD touch function
⑦	IDLE	• The engine is in the IDLE state(operation up to idle RPM) • The operation is performed on the digital panel with start permission
⑧	RUN	• The engine is in the RUN state(operating up to the target RPM) • The operation is performed on the digital panel with start permission

[Table 3-5]



[Fig. 3-15] IDLE Icon



[Fig. 3-16] RUN Icon

3. Part Names, Operation and Settings

3.8.1 Detailed User Setting



[Fig. 3-17] Detailed Settings

► User Setting Function and Description

- Press the setting button in the main screen for 3 seconds to enter the user setting.
- Use the arrow keys to move to the function you want to change.
- Press the Ok button to go to the gauge screen. (Auto save on change)

No.	Function	Description	Remark
1	Generator Setup	<ul style="list-style-type: none"> • Setting Up Engine Control Functions • Fine-tuning Engine RPM with TRIM, DROOP and AUX Settings 	
2	Engine Type	<ul style="list-style-type: none"> • Setting the Engine Model Installed on the Ship 	Reboot after changing the settings
3	Master / Slave	<ul style="list-style-type: none"> • Master / Slave setting when using multi-panel(V-Type/In-Line) 	-
4	Slave Engine Start	<ul style="list-style-type: none"> • Master/Slave start authorization On / Off • The start-up authorization can only be set on the Master Panel 	-
5	Korean/English	<ul style="list-style-type: none"> • Korean / English conversion 	-
6	Date Setup	<ul style="list-style-type: none"> • Set date and time 	-
7	USB BackUp	<ul style="list-style-type: none"> • Backup event and driving history files to USB 	-
8	Version	<ul style="list-style-type: none"> • Show as full integrated version of software 	Select S/W update item

[Table 3-6]

3. Part Names, Operation and Settings

3.8.2 Detailed Generator Setup



[Fig. 3-18] Generator Configuration Settings

No.	Function	Description	Remark
1	TRIM	<ul style="list-style-type: none"> Current TRIM Configuration Status OFF / Analog / Digital Mode 	Display Settings Mode on the Main Screen(①, Refer to Page Page17)
2	DROOP	<ul style="list-style-type: none"> DROOP Configuration Status Information 	Display Settings Mode on the Main Screen (②, Refer to Page Page17)
3	AUX	<ul style="list-style-type: none"> AUX Configuration Status Information 0~5V / -5V~5V Mode 	Display Settings Mode on the Main Screen (②, Refer to Page Page17))
4	SPEED RAMPING	<ul style="list-style-type: none"> SPEED RAMPING Configuration Status Information 	-

[Table 3-7]

► Generator Setup

- Generator Settings Screen Detailed Description: Composed of TRIM ENABLE(OFF, DIGITAL, ANALOG), TRIM Range, TRIM Digital, DROOP/AUX Enable(OFF, 0~5V, -5V~5V), DROOP/AUX Range, F-LOAD TORQUE, N-LOAD TORQUE, SPEED RAMPING
- The generator configuration items (TRIM, AUX, DROOP) are configured and applied through the digital panel set as Master, and can be viewed on the Slave digital panel with the settings made on the Master. However, the values cannot be changed on the Slave panel.
 - TRIM
 - TRIM ENABLE: The TRIM function for fine adjustment of the engine speed can be selected with digital input or analog input (OFF, ANALOG, DIGITAL).

3. Part Names, Operation and Settings

- TRIM Enable 「Digital」: When selected with digital input, the TRIM Digital value is applied.
 - 1) Set TRIM ENABLE to 「Digital」 and set the TRIM Digital value to 10 RPM within the TRIM Range. If the Target RPM is 60Hz 1800 (50Hz 1500), it will be output as 60Hz 1810 (50Hz 1510) (TRIM Digital value can only be set within the TRIM Range).
- TRIM Enable 「Analog」: Applies the ± variation value within the TRIM Range when TRIM is an analog input from a potentiometer.
 - 1) Set TRIM ENABLE to 「Analog」 and set the TRIM Range to ±5.0 RPM. In this case, the Target RPM of 1800 (1500) can be set within the range of ±5.0 RPM.
 - 2) When the input voltage of the potentiometer is 0V, it will output 1795 RPM for 60Hz (1495 RPM for 50Hz). When the voltage is 2.5V, it will output 1800 RPM for 60Hz (1500 RPM for 50Hz). And when the voltage is 5V, it will output 1805 RPM for 60Hz (1505 RPM for 50Hz)
- DROOP
 - DROOP Enable: Select whether to enable the DROOP function.
 - 1) OFF/DOOP ON setting
 - When DROOP Range (rpm) is set to ±10rpm and the Target RPM is for 60Hz, the formula is as follows:
 - 1) Target RPM value (60Hz) = (F-LOAD TORQUE - Engine Torque)/(F-LOAD TORQUE - N-LOAD TORQUE) X DROOP Range (RPM) value
 - 2) Example: F-LOAD TORQUE = 20, N-LOAD TORQUE = 10, Engine Torque = 10, DROOP Range = ±20 RPM. In this case, the Target RPM would be calculated as follows:
Target RPM = (20 - 10)/(20 - 10) X 20 = 1820 RPM
- AUX
 - AUX Enable: This allows the use of input signals from external load sharers or synchronization devices during parallel operation. There are two modes to choose from: -5V5V and 0V5V.
 - DROOP/AUX Range: This setting determines the speed variation of the engine for stable operation when AUX is enabled.
 - Adjustable range: 0 to 999 rpm
 - 1) -5V~5V Mode: When DROOP/AUX Range is set to ±10rpm, the output for -5V input would be 1790rpm (1490rpm for 50Hz) for 60Hz, 1800rpm (1500rpm for 50Hz) for 0V, and 1810rpm (1510rpm for 50Hz) for +5V input.
 - 2) 0V~5V Mode: When DROOP/AUX Range is set to ±10rpm, the output for 0V input would be 1790rpm (1490rpm for 50Hz) for 60Hz, and for +5V input, it would be 1810rpm (1510rpm for 50Hz)
- F-LOAD TORQUE, N-LOAD TORQUE:
 - Adjustable range: 0 to 9999 Nm
 - This setting is applicable only when DROOP is turned ON.
- SPEED RAMPING
 - The engine speed can vary up to the Target RPM based on the speed set by this setting.
 - It allows controlling the variation of the Target RPM based on the speed set in relation to the current RPM. The speed of variation is determined by the configured value. (Adjustable range: 1 to 30 seconds)

3. Part Names, Operation and Settings

3.9 Screen Layout

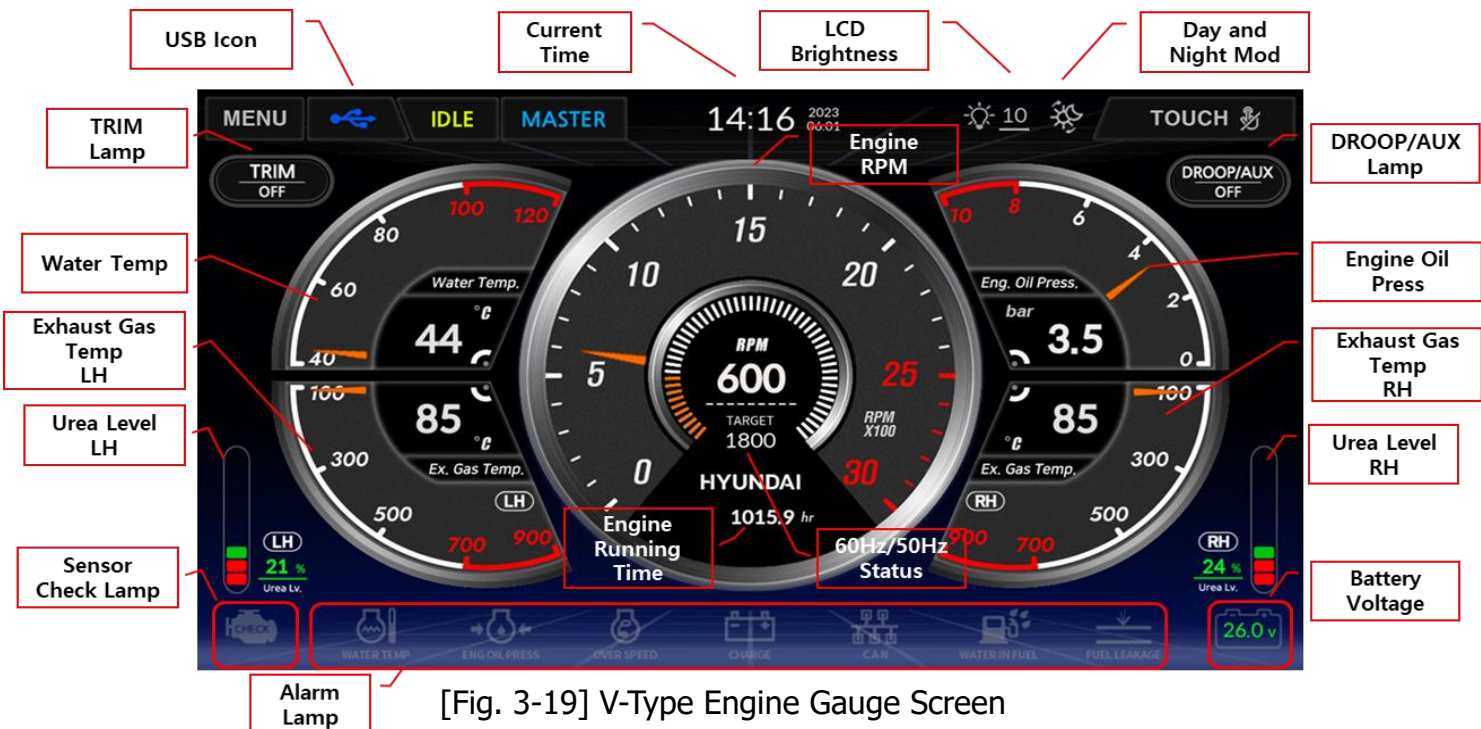

- The gauge functions include engine RPM, coolant temperature, exhaust gas temperature, engine oil pressure and more.
- In addition to the gauge elements LH/RH (for V-Type engines) or gauge element levels (for In-Line engines), there are also current time, USB detection icon, battery voltage, engine operation accumulated time, high coolant temperature, low engine oil pressure, overspeed, charging, CAN communication abnormality, water in fuel detection, and fuel leakage warning lights.

3. Part Names, Operation and Settings

3.9.1 Engine RPM

- The engine rpm is displayed as a gauge and a digital value, and the accumulated engine running time is counted.



[Fig. 3-21]
Engine RPM

- 1) The rpm value indicated by the needle is expressed more precisely as a digital number (digit). (However, the digit is always ON)
- 2) Displays the accumulated engine running time in 1 hour increments.
(Counts over 400rpm and is always on)
- 3) Fault Code for Overspeed Detection (V-Type Engine) B100100 / (In-Line Engine) B1001 - "Overspeed Detected" Pop-up Occurs / Indicator Displays "Shutdown" Icon.
- 4) For the 60Hz model, the default Target RPM is displayed as 1800.
 - Changes based on TRIM, AUX, and DROP application.
- 5) For the 50Hz model, the default Target RPM is displayed as 1500.
 - Changes based on TRIM, AUX, and DROP application.

3.9.2 Engine Cooling Water Temperature

- Cooling water temperature is displayed digitally with a gauge.



[Fig. 3-22]
Engine Cooling Water
Temperature

- 1) The temperature of the coolant pointed to by the needle is more precisely expressed as a digital number (digit). (However, the digit is always ON)
- 2) Fault code (V-Type Engine) P02174B / (In-Line Engine) P2185 pop-up when coolant high temperature is detected.
- 3) Coolant temperature warning lamp blinking and warning tone.

3. Part Names, Operation and Settings

3.9.3 Engine Oil Pressure

- Displays engine oil pressure with gauge and digital.



[Fig. 3-23]
Engine Oil Pressure Gauge

- 1) The oil pressure value indicated by the needle is more precisely expressed as a digital value (digit). (However, the digit is always ON)
- 2) Fault code received (V-Type Engine) P052484 / (In-Line Engine) P1521 pop-up occurs.
- 3) Warning lamp blinking and warning sounds.

3.9.4 Exhaust Gas Temperature

- Displays exhaust gas temperature with gauge and digital.



[Fig. 3-24]
Exhaust Gas Temperature

- 1) Express the exhaust gas temperature pointed by the needle more precisely as a digital number (digit). (However, the digit is always ON)
- 2) For In-Line Engines

3.9.5 Exhaust Gas Temperature LH

- Displays exhaust gas temperature with gauge and digital.



[Fig. 3-25]
Exhaust Gas Temperature LH

- 1) Express the exhaust gas temperature pointed by the needle more precisely as a digital number (digit). (However, the digit is always ON)
- 2) For V-Type Engines

3. Part Names, Operation and Settings

3.9.6 Exhaust Gas Temperature RH

- Displays exhaust gas temperature with gauge and digital.



[Fig. 3-26]
Exhaust Gas Temperature RH

- 1) Express the exhaust gas temperature pointed by the needle more precisely as a digital number (digit). (However, the digit is always ON)
- 2) For V-Type Engines

3.9.7 Urea Level

- Display urea level with gauge and digital.



[Fig. 3-27]
Urea Level

- 1) Express the urea level pointed by the needle more precisely as a digital number (digit). (However, the digit is always ON)
- 2) When the element level gauge displays a number below 20%, it will be shown in red, and when it is 21% or above, it will be displayed in white.
- 3) If there is no element level for a specific suffix, it will be displayed as "----".
- 4) For In-Line Engines

3.9.8 Urea Level

- Display urea level with gauge and digital.

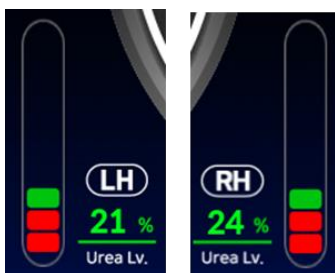

[Fig. 3-28]
Urea Level

- 1) The element level display bar and numeric display will be red when it is 20% or below, and green when it is 21% or above.
- 2) If a suffix does not have any aftertreatment, it will not be displayed on the screen.
- 3) For V-Type Engines

3. Part Names, Operation and Settings

3.9.9 Water In Fuel

- Indicates moisture detection when the water in fuel sensor is activated.



[Fig. 3-29] Water In Fuel

- 1) When "water in fuel" is detected and this condition is maintained for 10 seconds, a warning light flashes and a warning sound is emitted.
 - "Water In Fuel Detected" popup appears.
- 2) In case of sensor detachment (Open): "water in fuel Sensor Open Circuit Error" popup appears.
- 3) In case of Short: "water in fuel Sensor Short Circuit Error" popup appears.

3.9.10 Check Sensor Light

- When a sensor error (open, short) occurs, the sensor check light turns on



[Fig. 3-30] Check Sensor Light

- 1) If there is at least one alarm-triggering item, the indicator light will be illuminated.
- 2) In case of sensor error, the indicator light will be lit in red.
- 3) When the sensor error is resolved, the indicator light will be lit in orange.

3.9.11 Battery Voltage

- Displays the battery voltage to inform you of the battery status.



[Fig. 3-31] Battery Voltage

- 1) If the engine stop status is maintained at 24V or higher for 3 seconds, the indicator light will be green. If it is below 23.9V, the indicator light will be red.
- 2) the engine start status is maintained at 25.5V or higher for 3 seconds, the indicator light will be green. If it is below 25V, the indicator light will be red, accompanied by a warning sound.

3.9.12 TRIM, DROOP/AUX

- Depending on the TRIM, DROOP/AUX configuration, it will be illuminated or turned off, and the default setting is displayed as OFF.



[Fig. 3-32] Target RPM

- 1) Current TRIM (Analog, Digital) configuration status information.
- 3) DROOP/AUX ON, OFF configuration status information.
- 4) AUX 0V5V, -5V5V configuration status information
- 5) Setting for fine adjustment of engine speed and variation of speed for stable operation of the engine.
- 6) Configurable only on the digital panel set as Master.

3. Part Names, Operation and Settings

3.9.13 Engine Alarm

- When coolant temperature, engine oil pressure, gearbox oil pressure, charging, moisture detection, overspeed, fuel leakage, gearbox oil pressure, and battery voltage warning lights start flashing, an audible warning sound is triggered. (Applies to both V-Type and In-Line engine warning lights)



[Fig. 3-33] Engine Alarm

NO.	Alarm	Action Characteristics
①	COOLING WATER TEMP	· When coolant high-temperature detection occurs or when the (In-Line) P2185/(V-Type) P02174B fault code is received, the warning light will start flashing and an audible warning sound will be emitted.
②	ENGINE OIL PRESS	· When the (In-Line) P1521/(V-Type) P052484 fault code is received, the warning light will start flashing and an audible warning sound will be emitted.
③	OVER SPEED	· When the (In-Line) P0219/(V-Type) P021985 fault code is received, the warning light will start flashing, and an audible warning sound will be emitted. · When the Rate Speed exceeds 120%, the warning light will start flashing, an audible warning sound will be emitted, and the system will be shut down.
④	CHARGE	· When the (In-Line) P0562/(V-Type) P0560A2 fault code is received, the battery charging warning light will start flashing, and an audible warning sound will be emitted.
⑤	CAN	· When a CAN communication error occurs, the warning light will start flashing, and an audible warning sound will be emitted. · When the (In-Line) B1002/(V-Type) B100200 fault code is received, a "CAN Communication Error" popup will appear.
⑥	WATER IN FUEL	· When Water In Fuel detection conditions are maintained for 10 seconds (when the Water In Fuel sensor is activated), the warning light will start flashing, and an audible warning sound will be emitted.
⑦	FUEL LEAKAGE	· After 10 seconds of fuel leakage detection, the warning light will start flashing, and an audible warning sound will be emitted · (In-Line) B1005/(V-Type) B100500 When receiving fault code, "[Panel] Fuel Leak Detection" pop-up occurs
⑧	BATTERY VOLTAGE	· The display and audible warning sound will vary depending on the engine running or stopped status (refer to section 3.9.11 for details)

[Table 3-7] Warning light characteristics

3. Part Names, Operation and Settings

3.9.14 Engine Stop

- 1) When the engine RPM exceeds 115% of the Rate Speed (Shutdown).
- 2) If the current RPM is not received via CAN for 5 seconds during engine operation.
- 3) When the Emergency button is pressed.
- 4) In the event of fuel leakage.

※ How to turn off the engine warning light

- When the alarm condition is cleared and it is maintained for 3 seconds, the buzzer and lamp are automatically released and the lamp changes to orange

3.10 Other status

- It represents various states of the engine and the PAGE key in the function keys enable it to move to the sub-pages.



[Fig. 3-34] V-Type Engine Sub-Page Display Information

1. V-Type Engine Sub-Page Display Information

- When operated at 60Hz, the default displayed target RPM is 1800 rpm. For 50Hz operation, the default displayed target RPM is 1500 rpm.

3. Part Names, Operation and Settings

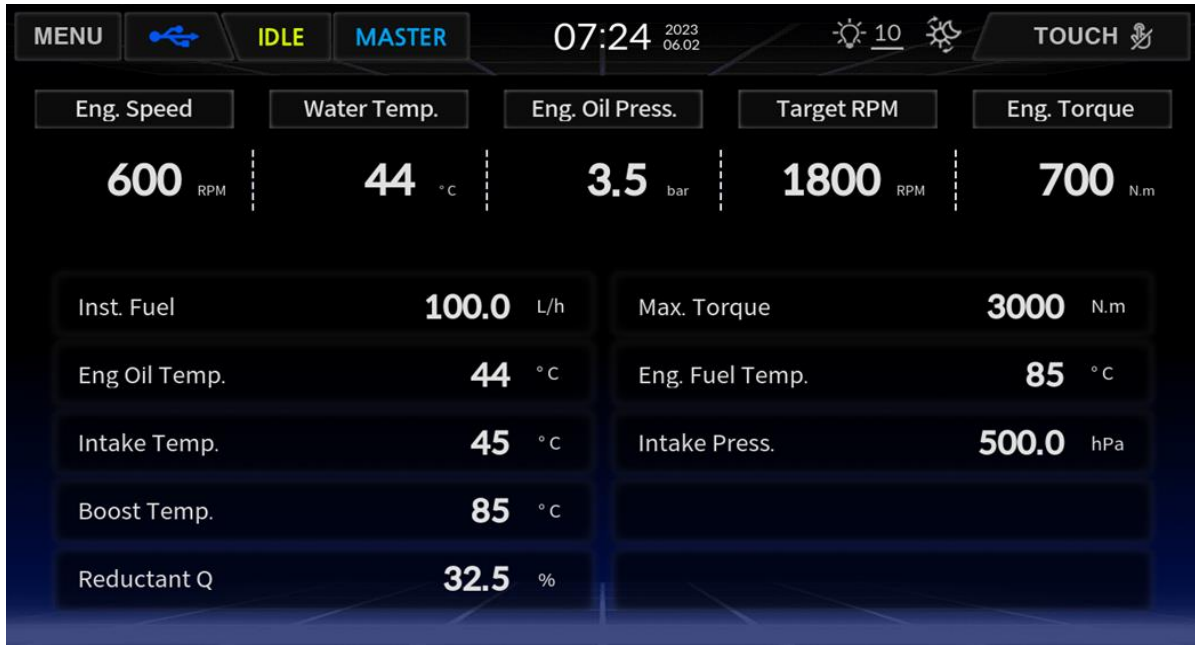

[Fig. 3-35] In-Line Engine Sub-Page Display Information

1. In-Line Engine Sub-Page Display Information

- For In-Line engines as well, similar to V-Type engines, the default displayed target RPM is 1800 rpm when operated at 60Hz, and 1500 rpm when operated at 50Hz.

Item (V-Type Engine)	Item (In-Line Engine)
Target RPM – (RPM) unit notation	Target RPM – (RPM) unit notation
Eng. Torque - (Nm) unit notation	Eng. Torque - (Nm) unit notation
Inst. Fuel - (L/h) unit notation	Inst. Fuel - (L/h) unit notation
Eng. Oil Temp - (°C) unit notation	Eng. Oil Temp - (°C) unit notation
Intake Temp - (°C) unit notation	Intake Temp - (°C) unit notation
Boost Temp(LH) - (°C) unit notation	Boost Temp - (°C) unit notation
Reductant Q(LH) - (%) unit notation	Reductant Q - (%) unit notation
Max. Torque - (Nm) unit notation	Max. Torque - (Nm) unit notation
Eng. Fuel Temp - (°C) unit notation	Eng. Fuel Temp - (°C) unit notation
Intake Press - (hPa) unit notation	Intake Press - (hPa) unit notation
Boost Temp(RH) - (°C) unit notation	
Reductant Q(RH) - (%) unit notation	

[Table 3-8] Sub-Page Display Items

3. Part Names, Operation and Settings

3.11 Current Fault Information Page

- While the engine is running, the ECU detects any abnormalities in the engine and, when a fault condition occurs, transmits the fault code via CAN communication. This fault code is received by the digital panel, and the fault code and description are displayed on the monitor as shown in [Fig. 3-36].
- Over-speed (115% of rated speed), CAN communication error, water in fuel, fuel leakage, and other faults are detected by the digital panel, triggering pop-up notifications.
- Up to 20 real -time fault messages are displayed, as shown in [Fig. 3-34].
- The fault code alarm window shown in [Fig. 3-37] is displayed on the screen whenever a fault code occurs, regardless of which page the user is working on.
- V-Type engines display the fault codes with 7 digits, while In-Line engines display them with 5 digits.

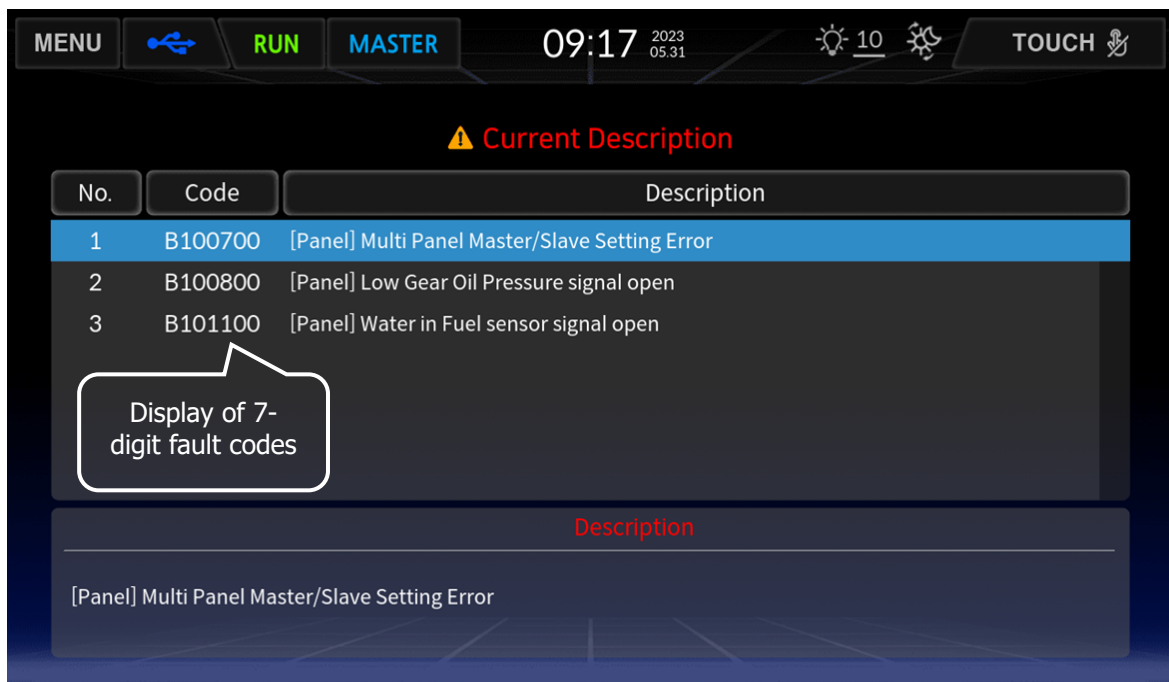

[Fig. 3-36] Current Fault Information Page

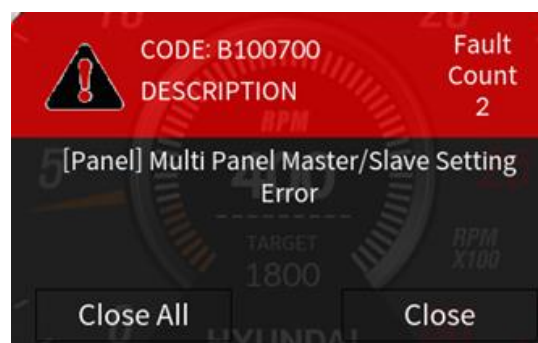

[Fig. 3-37] Fault Code Alarm Pop up

3. Part Names, Operation and Settings

3.12 Alarm Page

- It displays information about the number of engine starts, engine stops, engine abnormal stops, emergency starts, emergency stops, cumulative sensor alarm occurrences, and the date of the most recent alarm occurrence, all stored within the digital panel itself.
- Pressing the page buttons on the alarm screen will transit the display to the main page.
- V-Type engines display fault codes with 7 digits, while In-Line engines display fault codes with 5 digits.

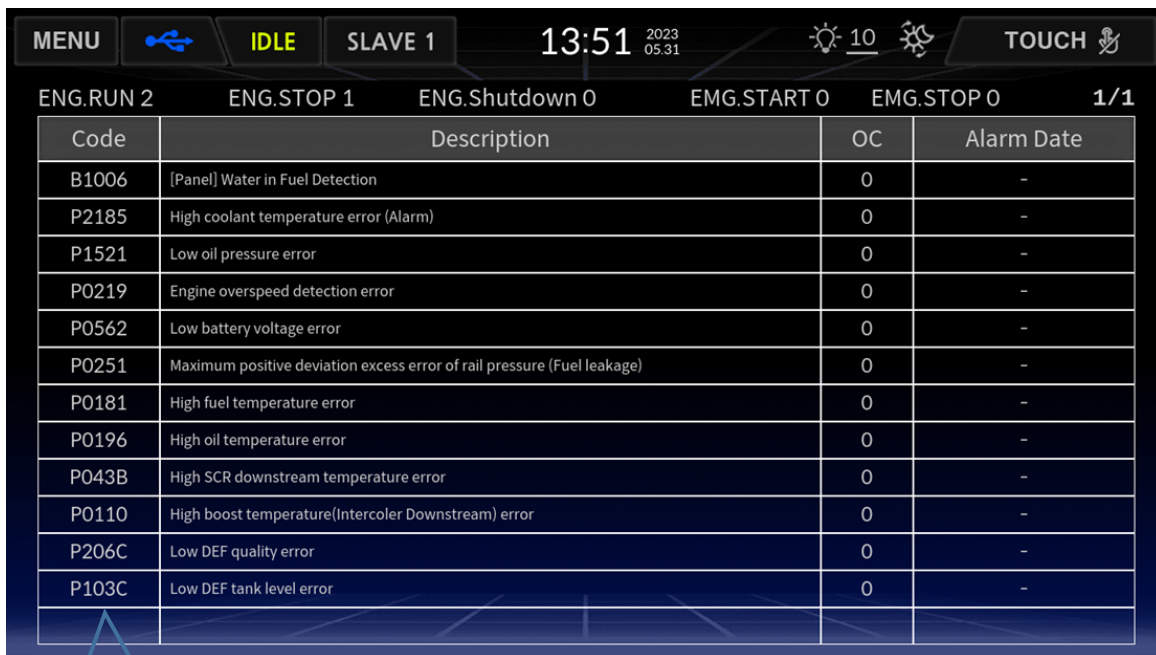

5-digit display

[Fig. 3-38] In-Line Engine Alarm Page Screen

In-Line Engine Alarm Page List			
B1006	[Panel] Water in Fuel Detection	P0181	High fuel temperature error
P2185	High coolant temperature error (Alarm)	P0196	High oil temperature error
P1521	Low oil pressure error	P043B	High SCR downstream temperature error
P0219	Engine overspeed detection error	P0110	High boost temperature
P0562	Low battery voltage error	P206C	Low DEF quality error
P0251	Maximum positive deviation excess error of rail pressure (Fuel leakage)	P103C	Low DEF tank level error

[Table 3-9] In-Line Engine Alarm Page List

3. Part Names, Operation and Settings

Code	Description	OC	Alarm Date
B100600	[Panel] Water in Fuel Detection	0	-
P02174B	[ECU] High coolant temperature error (Alarm)	0	-
P052484	[ECU] Low oil pressure error	0	-
P021985	[ECU] Engine overspeed detection error	0	-
P0560A2	[ECU] Low battery voltage error	0	-
P00017A	[ECU] Maximum positive deviation excess error of rail pressure(Fuel leakage) (RH bank)	0	-
P016885	[ECU] High fuel temperature error	0	-
P052085	[ECU] High oil temperature error	0	-
P042585	[DCU (RH)] Diagnostic Fault Check for Physical Signal above maximum temperature limit for SCR downstream	0	-
P043585	[DCU (LH)] Diagnostic Fault Check for Physical Signal above maximum temperature limit for SCR downstream	0	-
P007A85	[ECU] CAC upstream temperature high error of RH bank	0	-
P00A085	[ECU] CAC upstream temperature high error of LH bank	0	-
P207F84	[DCU (RH)] Diagnostic fault check for "physical signal below minimum limit" (DEF quality)	0	-

[Fig. 3-39] V-Type Engine Alarm Page Summary Screen

7-digit display

V-Type Engine Alarm Page List			
B100600	[Panel] Water in Fuel Detection	P042585	[DCU (RH)] Diagnostic Fault Check for Physical Signal above maximum temperature limit for SCR downstream
P02174B	[ECU] High coolant temperature error (Alarm)	P043585	[DCU (LH)] Diagnostic Fault Check for Physical Signal above maximum temperature limit for SCR downstream
P052484	[ECU] Low oil pressure error	P007A85	[ECU] CAC upstream temperature high error of RH bank
P021985	[ECU] Engine overspeed detection error	P00A085	[ECU] CAC upstream temperature high error of LH bank
P0560A2	[ECU] Low battery voltage error	P207F84	[DCU (RH)] Diagnostic fault check for "physical signal below minimum limit" (DEF quality)
P00017A	[ECU] Maximum positive deviation excess error of rail pressure(Fuel leakage) (RH bank)	P32E984	[DCU (LH)] Diagnostic fault check for "physical signal below minimum limit" (DEF quality)
P016885	[ECU] High fuel temperature error	P203F00	[DCU (RH)] Status of tank level is empty
P052085	[ECU] High oil temperature error	P32B900	[DCU (LH)] Status of tank level is empty

[Table 3-10] V-Type Engine Alarm Page List

3. Part Names, Operation and Settings

3.13 System Booting and Functional Check

- After installing the product, check to see if it has been installed properly

▶ Normal System Booting

- 1) After inserting the key into the key switch, if the key is rotated in the ON direction (right), it returns to the central point and is fixed.
- 2) HYUNDAI logo is displayed when the system is booted [Fig. 3-41]
 - ※ In case, the screen is not output when the key is rotated
 - Key OFF and then ON again
 - Check the harness connection behind the panel
 - Check for battery discharge
- 3) After booting normally, the gauge screen appears.[Fig. 3-42]
 - Gauge : Check that each gauge needle is within the normal range and check if it is displayed on the 'OPEN' or 'SHORT' screen
 - ※ When 'OPEN' or 'SHORT' occurs
 - Check the harness connection status
 - Function keys: Check whether each function key is operated normally
 - Warning light: Check if the warning light is on
 - Battery: Check if the battery voltage is normal
- 4) If there is no problem in the initial gauge screen, turn the key to start the engine.
- 5) Check RPM operation (initially 400RPM or higher, oil pressure 1bar or higher) and warning light on (red lamp blinks when warning light is on)

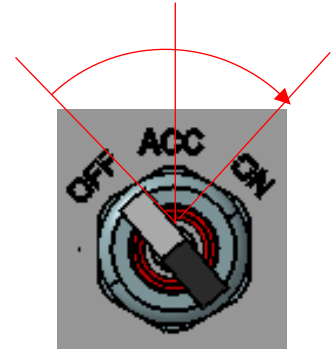

[Fig. 3-40] Key Switch



[Fig. 3-41] Boot Logo



[Fig. 3-42] Gauge Screen

4. Multi Panel Structure

4.1 Multi Panel

- It is possible to install up to 3 additional units except for the Master in the vessel, and it is possible to check and control the vessel status at any time depending on the setting. (However, be careful of the battery voltage drops as the length of the harness increases.)

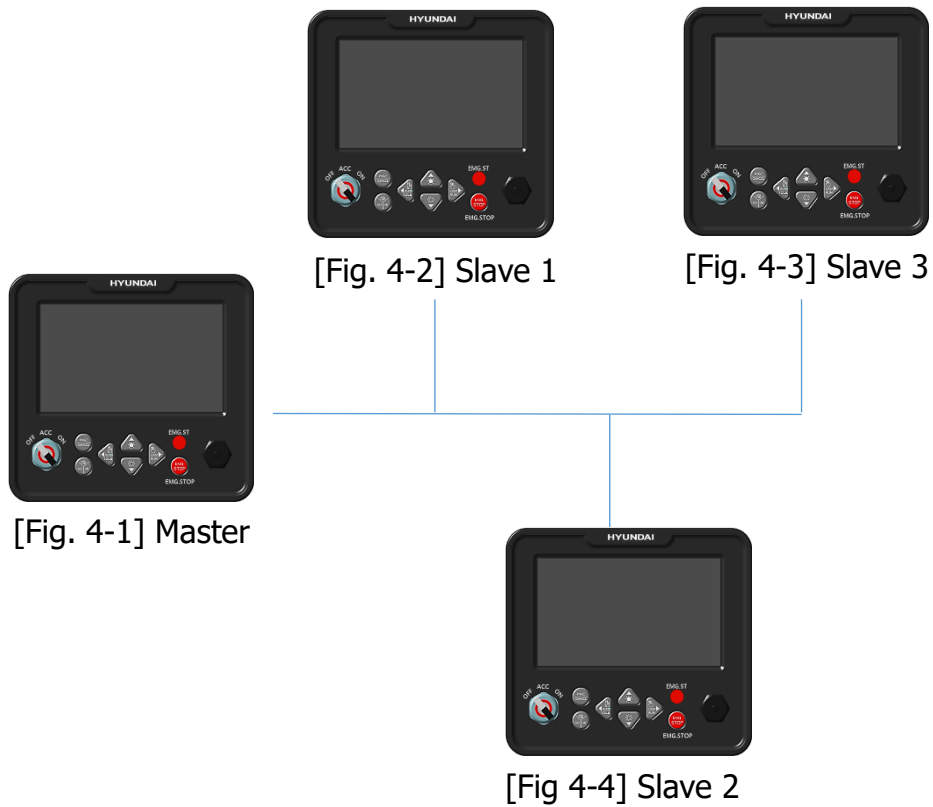

4. Multi Panel Structure

4.2 How to Install Multi Panel

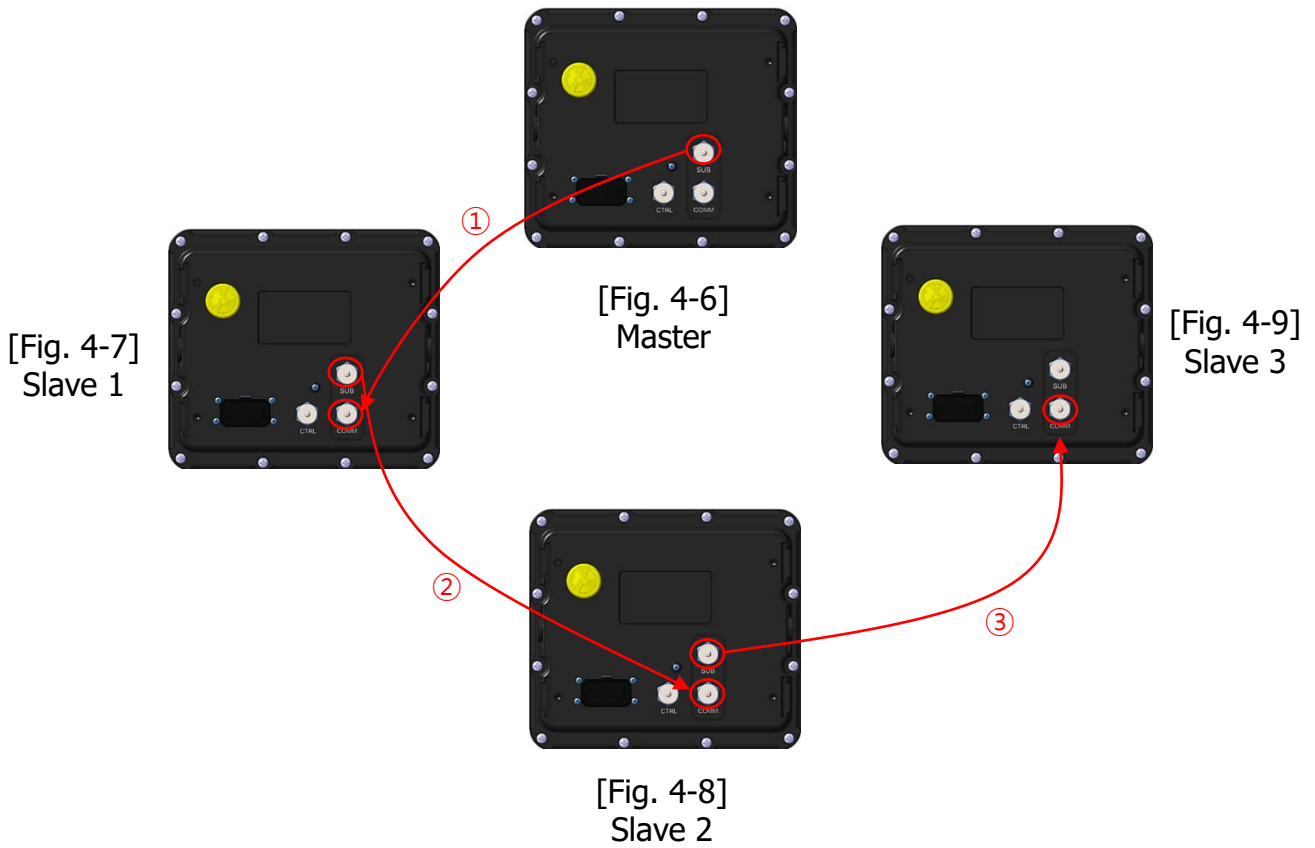

※ Before installing the multi-panel, the necessary cables should already be prepared.
(Cables should use HD Hyundai InfraCore recommended specifications)

(1) Connect the SUB terminal of the Master panel to the main connector terminal of the Slave 1 panel as shown in ①. (2 panels)

- Master and Slave 1 connection completed

(2) In the state connected as in ① above, as in ②, that is, connect Slave1(COMM) to Slave2(SUB). (3 panels)

- Master, Slave 1, Slave2 connection completed

4. Multi Panel Structure

4.3 Multi Panel Setting

- (1) Press and hold the OK button of the panel to be set in Slave mode for 3 seconds.
- (2) When the Settings window opens, navigate to Figure ① (Use the directional keys to navigate).
- (3) Press the OK button to switch between Master / Slave1 / Slave2 / Slave3.
 - ※ Note: When connecting multiple Slaves, the Slave mode settings should not overlap.
- (4) Set the panel to Master mode using the same method as above.

※ Note

- Only one product can be set in Master mode, and up to two Slaves are recommended.
- If the cable length between Master and Slaves is more than 30m, there may be a voltage drop of more than 1V, so it needs to be checked.
- Granting engine start permission to Slave panels can only be done from the Master panel.
 - In the "Remote Engine Start" menu of the Master panel, select the Slave to grant engine start permission
 - When granting engine start permission to a Slave, the Master loses its own engine start permission.
 - Panels with engine start permission are indicated by colored icons on the indicator [Fig. 4-10 ②][Fig. 4-12].
- When a panel without engine start permission attempts to start the engine, a "No engine start permission" popup appears [Fig. 4-11].
- If both Master and Slave panels have duplicated settings for Local/Remote (e.g., Master, Master), a "[Panel] Multi Panel Local/Remote Setting Error" popup appears [Fig. 4-13].
- Emergency engine start is only possible from the Master panel, and emergency engine stop is possible from any Slave.
 - Slave emergency engine stop operates via CAN communication.
- Re-engaging the starter is not possible during engine operation (except for Emergency Start from the Master panel)



[Fig. 4-10] Multi Panel Settings Popup

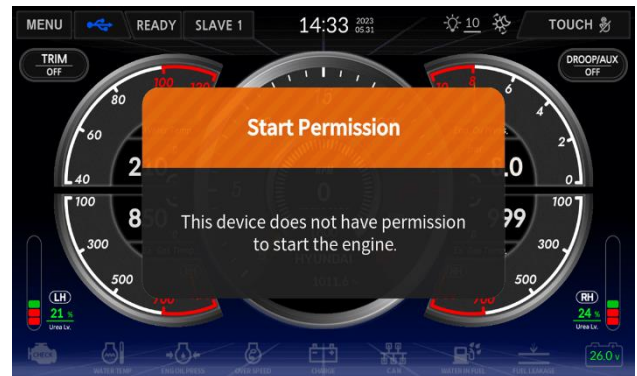

[Fig. 4-11] Engine Start Authorization Popup

4. Multi Panel Structure

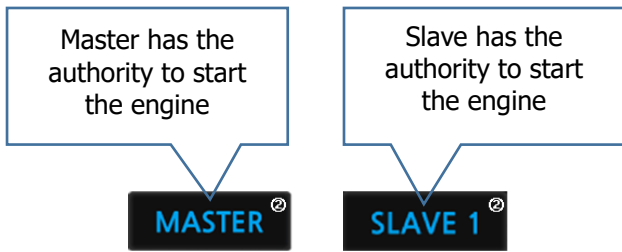

[Fig. 4-12] Master/Slave Start Authorization



[Fig. 4-13] Multi Panel Settings Error

5. Maintenance

5.1 Maintenance

- To maintain the performance of the device, regular maintenance is required.
- 1. Use soft cloth to clean the LCD without damaging it.
 - 1) Clean the LCD after turning the power off.
 - 2) Do not use cleaners with acids or ammonia.
 - 3) Do not use neutral detergents to remove oil stains.
 - 4) Use cloth slightly wet with clean water to remove salt residuals or dust particles for natural drying. If there remain stains, clean them with soft cloth (microfibers) once again.
- 2. Check whether the connectors or harnesses at the back of the device are properly connected or whether they have dust or other foreign substances.
- 3. Check whether cables are damaged.
- 4. Request for checking when the software needs upgrade as follows:
 - When the manufacturer releases official software for performance improvements

5.2 Troubleshooting

- It describes possible measures for users to resolve problems while using the device
- 1. The device is not turned on.
 - 1) Check whether harness cables at the back of the product are properly connected.
 - 2) Where harness cables have too much dust or moisture, remove them and clean the dust or moisture. Connect them once again after a while.
 - 3) Check whether the fuse button at the back of the product is pulled out.
 - 4) Check whether the battery is discharged.
- 2. You can see lines or shaking on the screen.
 - 1) Reboot the product.
 - 2) As the LCD is connected inside the product, do not disassemble it and contact the service team.
- 3. You can see alarm or hear warning beeps at the bottom of the product screen.
 - 1) Check where the alarm occurs and then take measures as necessary (if you need to confirm which alarm occurs, refer to Page 20 of this manual).
- 4. You cannot control buttons.
 - 1) Check whether there are foreign substances at the panel buttons.
 - 2) As the button connecting parts may be damaged, do not disassemble the product and contact the service team.

6. Warranty and A/S Service

6.1 Warranty

- As this manual contains important contents related to safety, use and maintenance of the product. So please read this manual carefully and then use the product in a proper manner.

Those who are not familiar with the product should keep this manual close to themselves.

We are not responsible for human injuries or property damages caused by the following reasons:

- Where you use the product for purposes other than the ones described in this manual
- Where you alter the product or its components at discretion
- Where you disassemble the product at discretion to resolve problems
- Where you use accessories or parts not supplied or recommended by us
- ※ Where you use accessories or parts manufactured by other companies, please contact our service

6.2 A/S Service Information

- When you request A/S service, please let us know the model name, breakdown conditions and your contact information.
- Please ask the seller.

User Manual for 8 Inch Digital Panel for Electronic Marine Propulsion Engine

Ver.1.0



HYUNDAI

► Contents

1. General Information

1.1	Product Information	3
1.2	Components and Optional Accessories	3
1.3	Product Specification	4

2. Product Installation

2.1	Cautions	5
2.2	Desk Mounting Type	6
2.3	Flush Mounting Type	7

3. Part Names, Operation and Settings

3.1	Front Side	8
3.2	Back Side	8
3.3	External Connection Terminals	9
3.3.1	DGP 23Pin Main Connector	9
3.3.2	Circular Interface Connector	10
3.3.3	USB Connector	10
3.4	Internal Buzzer	11
3.5	Key Switch	11
3.6	Emergency Start Button	12
3.7	Emergency Stop Button	12
3.8	Function Keys	13
3.8.1	Detailed User Settings	14
3.9	Display Structure	15
3.9.1	Engine RPM	16
3.9.2	Engine Cooling Water Temperature	16
3.9.3	Engine Oil Pressure	17
3.9.4	Exhaust Gas Temperature	17
3.9.5	Exhaust Gas Temperature LH	17
3.9.6	Exhaust Gas Temperature RH	18
3.9.7	Gearbox Pressure	18
3.9.8	Urea Level	18
3.9.9	Gearbox Oil Pressure	19
3.9.10	Water In Fuel	19
3.9.11	Check Sensor Light	19

► Contents

3.9.12	Battery Voltage	-----	19
3.9.13	Engine Alarm	-----	20
3.9.14	Engine Stop	-----	21
3.10	Spare Status	-----	22
3.11	Current Fault Information Page	-----	24
3.12	Alarm Page	-----	25
3.13	System Booting and Functional Check	-----	27
4. Multi Panel Structure			
4.1	Multi Panel	-----	28
4.2	How to Install Multi Panel	-----	29
4.3	Multi Panel Settings	-----	30
5. Maintenance			
5.1	Maintenance	-----	32
5.2	Troubleshooting	-----	32
6. Warranty and A/S Service			
6.1	Warranty	-----	33
6.2	A/S Service Information	-----	33

1. General Information



1.1 Product Information

This product is a digital panel for electronic propulsion engine displays and can be applied to various small marine engines. The DGP model is designed to be robust for marine environments and is equipped with digital visualization to clearly monitor engine control and status information. It provides information through graphical analog gauges and digital displays, aiming to enhance user convenience.

1.2 Components and Optional Accessories

- Refer to Table 1-1 below for product components
- Reference
DGP: Digital Gauge Panel

Components

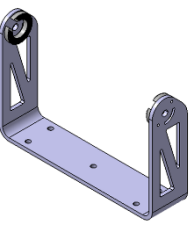
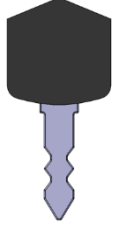
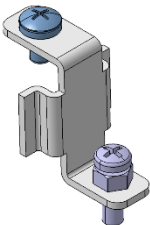
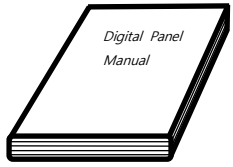
NO	Components	Component Name	NO	Components	Component Name
1		DGP	4		Desk Mounting Type Parts 1set
2		Desk Mounting Type Bracket	5		Key 2EA
3		Flush Mounting Type Bracket 4EA	6		User Manual

[Table 1-1]

1. General Information

1.3 Product Specification

- Refer to Table 1-2 below for the hardware specifications of the digital panel for this electronic engine

Digital Gauge panel product Specification

No.	Item	Remark
1	Microprocessor	<ul style="list-style-type: none">• NXP4330Q / S32K144
2	Software	<ul style="list-style-type: none">• Linux OS GUI + F/W
3	Display	<ul style="list-style-type: none">• 8" Color TFT LCD• 1280 * 720(Pixel)• 16 : 9
4	Flash Memory	<ul style="list-style-type: none">• 4GB(eMMC)
5	Ram	<ul style="list-style-type: none">• 1GB
6	Operating Voltage	<ul style="list-style-type: none">• 9V ~ 30V DC
7	USB	<ul style="list-style-type: none">• USB 2.0 1Port
8	Operating Temperature	<ul style="list-style-type: none">• - 20°C ~ 70°C
9	Operating Temperature	<ul style="list-style-type: none">• Piezo Buzzer 98dB
10	Internal Buzzer	<ul style="list-style-type: none">• SAE J1939 CAN communication• RS232
11	Communication	<ul style="list-style-type: none">• W 287 x H 245.8 x D 107.1(DGP)

[Table 1-2]

2. Product Installation

2.1 Cautions

- Unskilled personnel should read this manual before use.
- Do not use or keep the product close to combustible sprays or inflammables.
- Use soft and dry cloth to clean the panel LCD.
- Turn off the product, pull out the harness cable and then contact our service center when you see smoke from the panel or have strange smells.
- When you see an alarm on, you always need to check the product before operation.
- Do not disassemble the product cover at discretion (warranty does not cover unauthorized disassembly).
- Excessive impact may damage the display although a reinforced display is used.
- Use connectors matching each other when connecting them to the back of the product.
- Do not contact or remove connectors while the power is on. It may cause electric shock or lead to malfunction.
- Do not exercise excessive force when rotating to ON/OFF with the key inserted in.
- Do not use the product with wet hands.
- Put protective caps on back side connectors when they are not in use.

2. Product Installation

2.2 Desk Mounting Type

- ※ Desk Mounting Types are installed in the steering or engine room by using desk mounting brackets delivered with the product.
- ※ Mounting Hole Spec: M6 bolt

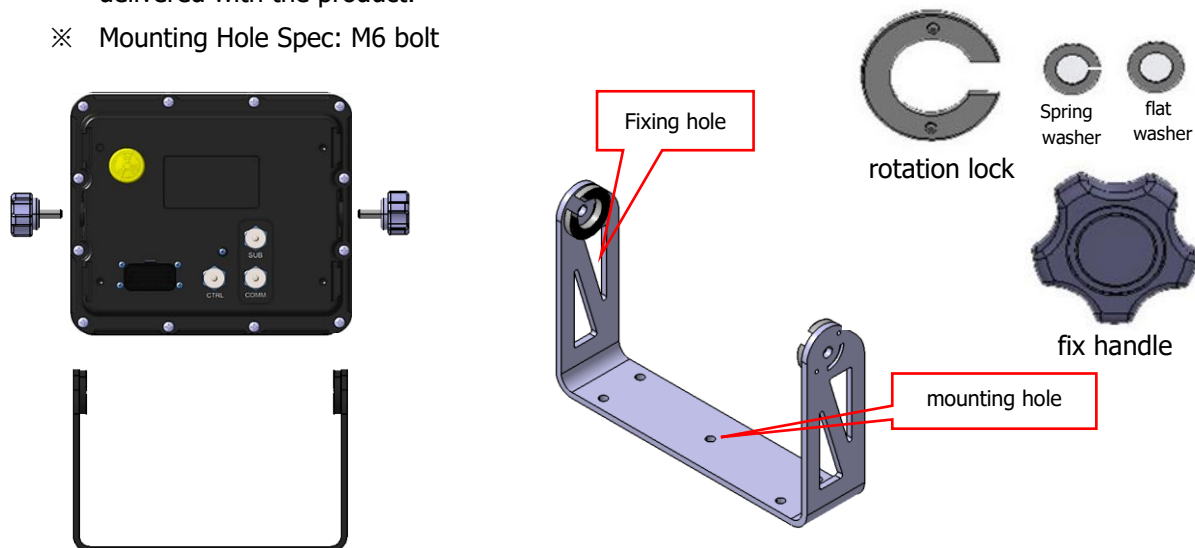

[Fig. 2-1] Desk Mounting Type Diagram

► Installing Desk Mounting Type digital panel

- ① Check if there is cable wiring available in the wheelhouse or engine room.
- ② Fix the bracket using mounting hole of the product at the position where the cable wiring reaches.
- ③ Place the product inside the bracket connected with the rotation lock to connect it with the rotation lock.
- ④ Connect it with the fix handle to the direction indicated by an arrow and adjust the viewing angle of the LCD

※ Where there are things to which the product can be fixed, use spare holes with the bolt or other accessories.

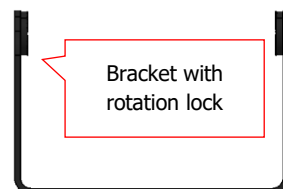

[Fig. 2-2]

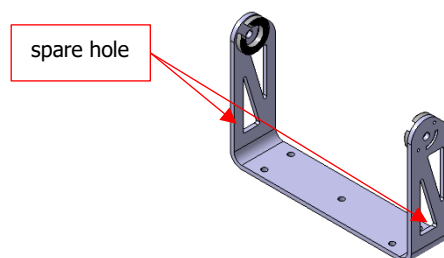
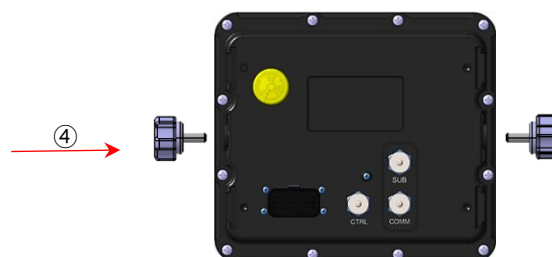

[Fig. 2-3]

2. Product Installation

2.3 Flush Mounting Type

- Flush Mounting types are installed in a steering or engine room by using optional mounting brackets (2pcs).

※ Bolt Spec: ① M6 X 10L ② M6 X 20L

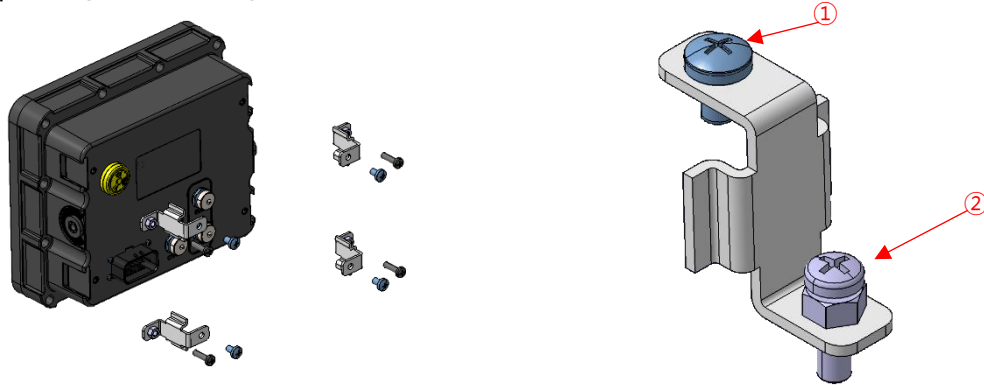

[Fig. 2-4] Flush Mounting Type Diagram

► Installing Flush Mounting Type digital panel

- ① Check the harness is wired in the steering or engine room.
- ② As shown in [Fig. 2-5], fix the mounting brackets to both sides of the panel.
- ③ Check the location within reach of the harness wiring and the mounting location and then mount the panel using proper bolts.
- ④ Finish gaps between the product and the structure depending on the mounting conditions and connect the engine harness (you may connect the engine harness first depending on conditions)

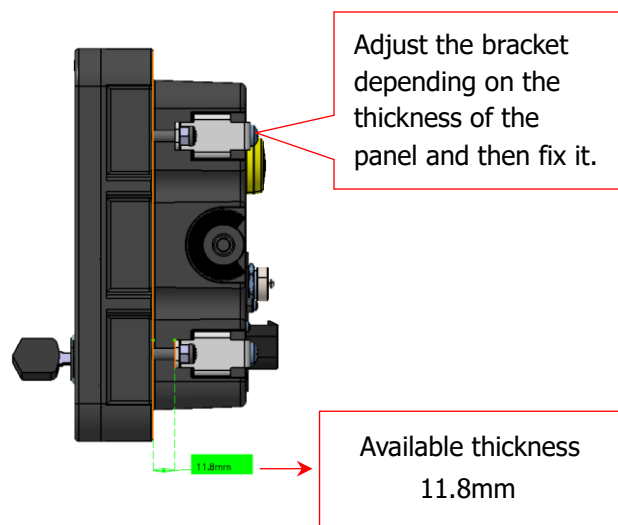

[Fig. 2-5]

3. Part Names, Operation and Settings

3.1 Front Side



[Fig. 3-1]

No.	Name	Reference
①	LCD	-
②	Function Keys	13 Page
③	Key Switch	11 Page
④	USB	10 Page
⑤	Emergency Start Switch	12 Page
⑥	Emergency Stop Switch	12 Page

[Table 3-1]

3.2 Back Side

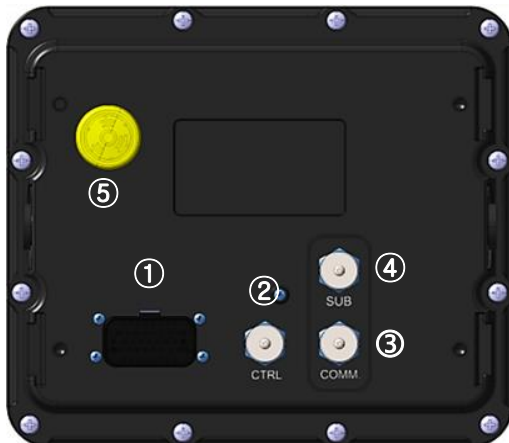

[Fig. 3-2]

No.	Name	Reference
①	Main Connector	9 Page
②	Engine Control (External Buzzer and Function for Ship Generator)	10 Page
③	COMM. (CAN / RS-232)	10 Page
④	SUB	10 Page
⑤	Internal Buzzer	11 Page

[Table 3-2]

3. Part Names, Operation and Settings

3.3 External Connection Terminals

- Input/output connector connecting DGP and ECU
- Input/output connector for various control signals including sensors between ECU and engine

3.3.1 DGP 23Pin Main Connector

- Interface connector for receiving power and vessel operation information from ECU and transmitting and receiving CAN signals

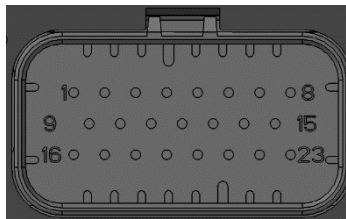

[Fig. 3-3]

No.	Pin Description	Notes	No.	Pin Description	Notes
1	BATT IN	-	13	PC RXD1	-
2	BATT IN	-	14	PC TXD1	-
3	Power GND	-	15	Alternator IN	-
4	Power GND	-	16	Wait to Disconnect Signal	
5	Key ON	-	17	Wait to Disconnect Common	
6	STARTER Signal	-	18	Gearbox Oil Pressure Supply	
7	Emergency Switch Power	-	19	Gearbox Oil Pressure Signal	
8	Emergency Switch Signal	-	20	Fuel Leakage Switch	
9	CAN 2(J1939) High	-	21	GND Sensor	
10	CAN 2(J1939) Low	-	22	Water IN Fuel Sensor	
11	CAN 1(UDS) High	Option	23	GND Sensor	
12	CAN 1(UDS) Low		-	-	

[Table 3-3]

3. Part Names, Operation and Settings

3.3.2 Circular Interface Connector

- CTRL : Buzzer output connector for external buzzer connection
- COMM. : Multi-panel[OUT], communication connector for power and CAN communication
- SUB : Multi-panel[IN], communication connector for power and CAN communication

No.	CTRL	COMM.	SUB
1	BUZZ BATT	Key-ON	Key-ON
2	BUZZ OUT	BATT IN	BATT IN
3	VCC	CAN1 H	CAN1 H
4	RPM_TRIM	CAN1 L	CAN1 L
5	GND	CAN2 H	CAN2 H
6	ISO_AUX+	CAN2 L	CAN2 L
7	ISO_AUX-	GND	GND
8	GND	-	-

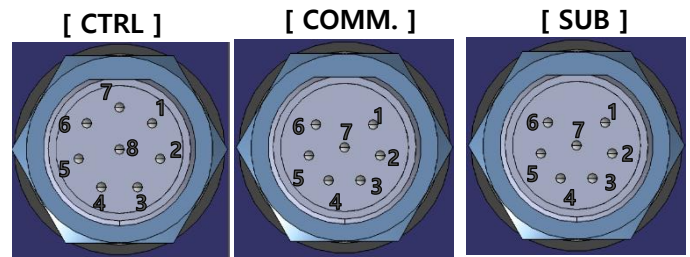

[Fig. 3-4]

[Table 3-4]

3.3.3 USB Connector

- When backing up driving record data and upgrading software, insert a USB memory (FAT32 format is used)



[Fig. 3-5-1]



[Fig. 3-5-2]

3. Part Names, Operation and Settings

3.4 Internal Buzzer

- Buzzer sound when an alarm occurs due to engine abnormality.
- It operates at 98dB, and an external large-capacity buzzer can be additionally installed.



[Fig. 3-6]

3.5 Key Switch

- Digital panel system boot, engine start, and engine stop functions.
 - 1) After inserting the key included in the product in the key switch and turning it to the position of 45° to the right (ACC), the product is booted.
 - 2) Engine starts at the position of 90° turn (ON) and it returns to 45° position (If the key is in the ON state, keep the key lock state)
 - 3) When ACC is ON, the product boots within 5 seconds and the gauge screen is output after the introduction screen.
 - 4) Turn the key 45° to the left (OFF) when the engine is stopped
 - When the key is rotated to the left (OFF) position in Engine operation, in case, the panel power is turned off and the ECU is still operational, the "System Power Shutdown" alarm message window will pop up, and the engine will be shut down as shown in [Fig. 3-9].
 - When the pop-up window appears, rotate the key to the right (ON) position, then the pop-up window will disappear, and the engine will remain in the ON state.

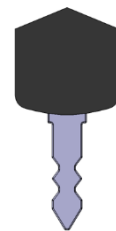

Key
[Fig. 3-7]



Key Switch
[Fig. 3-8]

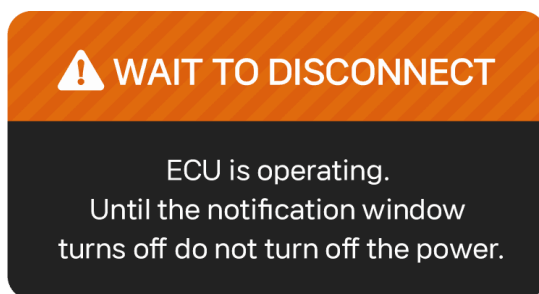

[Fig. 3-9]

3. Part Names, Operation and Settings

3.6 Emergency Start Button

- Used to force the engine to start in an emergency situation.
 - 1) In the OFF state of the key, rotate the key to ON while pressing it with an available device for the buttonhole.
- ※ Application of safety accident prevention function
- ※ Hole Size : Ø7

- ※ It should be used only in emergency situations and product life may be affected when used.

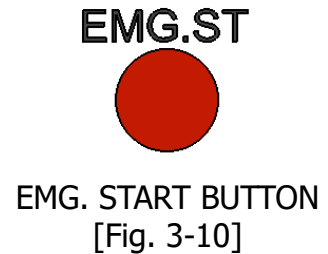

3.7 Emergency Stop Button

- Used to stop the engine in an emergency situation.
 - 1) Press immediately in case of emergency in engine running.
 - 2) When the emergency stop is activated, and audible alarm will sound, and the emergency stop pop up window [Fig. 3-12] will be displayed on the LCD screen, while the engine RPM decreases.
 - 3) The indicator will display the Shutdown icon [Fig. 3-13]
 - 4) Emergency stop status is not lifted until Key is off.
- ※ If the button is released within a short period of time, the engine may not be stopped.
- ※ It should be used only in emergency situations and product life may be affected when used.

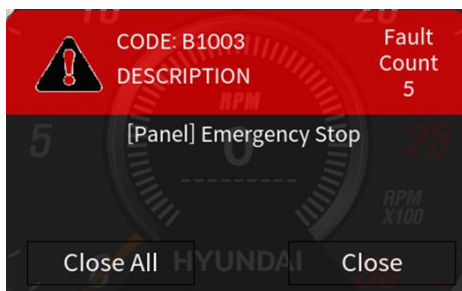

3. Part Names, Operation and Settings

3.8 Function Keys

- Functions such as panel setting, alarm stop, menu movement, and selection.

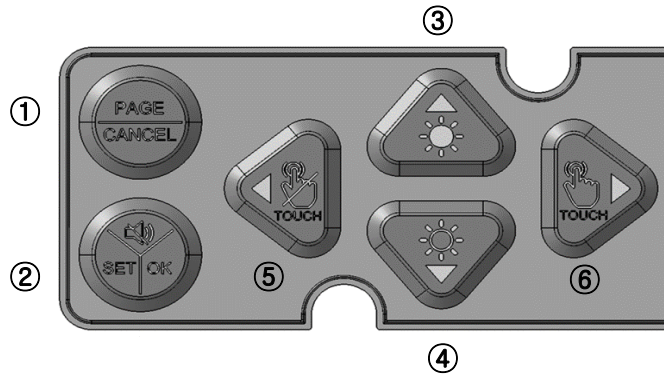

[Fig. 3-14] Function Keys

NO.	Function	Action Characteristics
①	Page	• switch page / cancel
②	Ok	• Enter setting, save setting value
③	Up	• Cursor movement (up), setting value change (increase), screen brightness increase
④	Down	• Cursor movement (down), setting value change (decrease), screen brightness decrease
⑤	Left	• Cursor movement (left), Lock LCD touch function
⑥	Right	• Cursor movement (right), unlock LCD touch function

[Table 3-5]

3. Part Names, Operation and Settings

3.8.1 Detailed User Setting



[Fig. 3-15] Detailed Settings

► User Setting Function and Description

- Press the setting button in the main screen for 3 seconds to enter the user setting.
- Use the arrow keys to move to the function you want to change.
- Press the Ok button to go to the gauge screen. (Auto save on change)

No.	Function	Description	Remark
1	Engine Type	• Setting the Engine Model Installed on the Ship	Reboot after changing the settings
2	Master / Slave	• Master / Slave setting when using multi-panel(V-Type/In-Line)	-
3	Slave Engine Start	• Master/Slave start authorization On / Off • The start-up authorization can only be set on the Master Panel	-
4	Korean/English	• Korean / English conversion	-
5	Date Setup	• Set date and time	-
6	USB BackUp	• Backup event and driving history files to USB	-
7	Version	• Show as full integrated version of software	Select S/W update item

[Table 3-6]

3. Part Names, Operation and Settings

3.9 Screen Layout

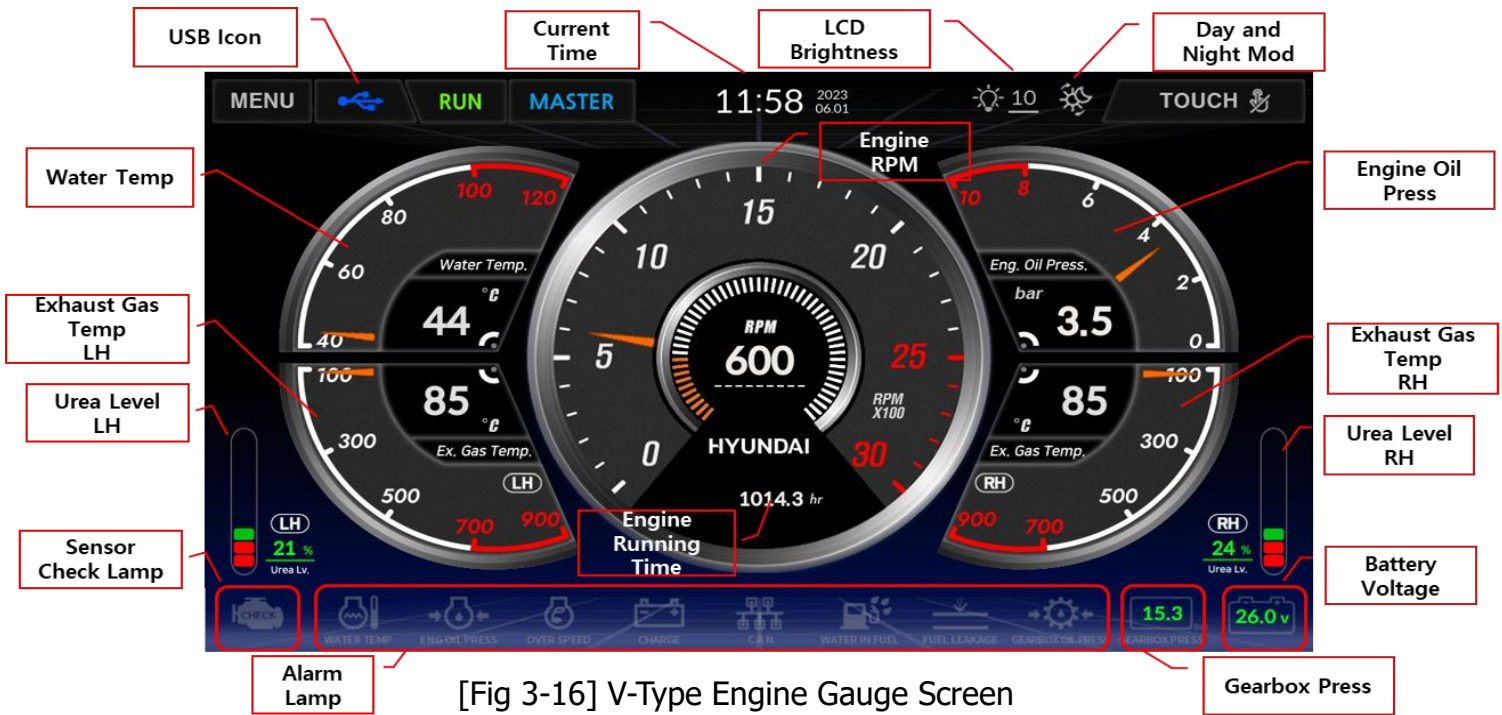

[Fig 3-16] V-Type Engine Gauge Screen



[Fig. 3-17] In-Line Engine Gauge Screen

- The gauge functions include engine RPM, coolant temperature, exhaust gas temperature, engine oil pressure, gearbox oil gauge and more.
- In addition to the gauge elements LH/RH (for V-Type engines) or gauge element levels (for In-Line engines), there are also current time, USB detection icon, battery voltage, engine operation accumulated time, high coolant temperature, low engine oil pressure, overspeed, charging, CAN communication abnormality, moisture detection, fuel leakage and gearbox oil gauge warning lights.

3. Part Names, Operation and Settings

3.9.1 Engine RPM

- The engine rpm is displayed as a gauge and a digital value, and the accumulated engine running time is counted.



[Fig. 3-18]
Engine RPM

- 1) The rpm value indicated by the needle is expressed more precisely as a digital number (digit). (However, the digit is always ON)
- 2) Displays the accumulated engine running time in 1 hour increments.
(Counts over 400rpm and is always on)
- 3) Fault Code for Overspeed Detection (V-Type Engine) B100100 / (In-Line Engine) B1001 - "Overspeed Detected" Pop-up Occurs / Indicator Displays "Shutdown" Icon.

3.9.2 Engine Cooling Water Temperature

- Cooling water temperature is displayed digitally with a gauge.



[Fig. 3-19]
Engine Cooling Water
Temperature

- 1) The temperature of the coolant pointed to by the needle is more precisely expressed as a digital number (digit). (However, the digit is always ON)
- 2) Fault code (V-Type Engine) P02174B / (In-Line Engine) P2185 pop-up when coolant high temperature is detected.
- 3) Coolant temperature warning lamp blinking and warning tone.

3. Part Names, Operation and Settings

3.9.3 Engine Oil Pressure

- Displays engine oil pressure with gauge and digital.



[Fig. 3-20]
Engine Oil Pressure Gauge

- 1) The oil pressure value indicated by the needle is more precisely expressed as a digital value (digit). (However, the digit is always ON)
- 2) Fault code received (V-Type Engine) P052484 / (In-Line Engine) P1521 pop-up occurs.
- 3) Warning lamp blinking and warning sounds.

3.9.4 Exhaust Gas Temperature

- Displays exhaust gas temperature with gauge and digital.



[Fig. 3-21]
Exhaust Gas Temperature

- 1) Express the exhaust gas temperature pointed by the needle more precisely as a digital number (digit). (However, the digit is always ON)
- 2) For In-Line Engines

3.9.5 Exhaust Gas Temperature LH

- Displays exhaust gas temperature with gauge and digital.



[Fig. 3-22]
Exhaust Gas Temperature LH

- 1) Express the exhaust gas temperature pointed by the needle more precisely as a digital number (digit). (However, the digit is always ON)
- 2) For V-Type Engines

3. Part Names, Operation and Settings

3.9.6 Exhaust Gas Temperature RH

- Displays exhaust gas temperature with gauge and digital.



[Fig. 3-23]

Exhaust Gas Temperature RH

- 1) Express the exhaust gas temperature pointed by the needle more precisely as a digital number (digit)
(However, the digit is always ON)
- 2) For V-Type Engines

3.9.7 Gearbox Pressure

- The gearbox pressure is displayed using gauges and digitally



[Fig. 3-24]

Gearbox Pressure

- 1) The gearbox pressure value indicated by the needle is displayed more precisely as a digital value (digits) (Note: Digits are always ON).
- 2) Diagnose open or short circuit when a sensor malfunction occurs.
- 3) When the ignition state is below 1 bar, a warning light and alarm sound are activated (if detected for more than 10 seconds).
- 4) For In-Line Engines

3.9.8 Urea Level

- Display urea level with gauge and digital.

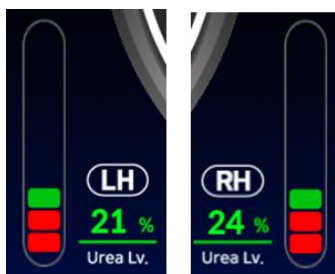

[Fig. 3-25]

Urea Level

- 1) The element level display bar and numeric display will be red when it is 20% or below, and green when it is 21% or above.
- 2) If a suffix does not have any aftertreatment, it will not be displayed on the screen.
- 3) For V-Type engines
- 4) For in-line engines, there is only one gauge available without distinguishing between RH and LH(Refer to [Fig. 3-17] In-Line Engine Gauge Screen).

3. Part Names, Operation and Settings

3.9.9 Gearbox Oil Pressure

- The gearbox oil pressure is displayed digitally.



[Fig. 3-26]
Gearbox Oil Pressure

- 1) The gearbox oil pressure value is represented in a more precise digital format, using digital digits. However, the digits are always displayed as ON.
- 2) When a fault code is received, a "Low gearbox oil pressure" popup appears.
- 3) If the engine is running with a pressure below 1 bar for 10 seconds, a warning light flashes with a red numerical display. If the engine maintains a pressure of 1.5 bar or above for 3 seconds, the warning is cleared, and a green display appears.
- 4) For V-Type Engines

3.9.10 Water In Fuel

- Indicates moisture detection when the water in fuel sensor is activated.



[Fig. 3-27] Water In Fuel

- 1) When "water in fuel" is detected and this condition is maintained for 10 seconds, a warning light flashes and a warning sound is emitted.
 - "Water In Fuel Detected" popup appears.
- 2) In case of sensor detachment (Open): "water in fuel Sensor Open Circuit Error" popup appears.
- 3) In case of Short: "water in fuel Sensor Short Circuit Error" popup appears.

3.9.11 Check Sensor Light

- When a sensor error (open, short) occurs, the sensor check light turns on



[Fig. 3-28] Check Sensor Light

- 1) If there is at least one alarm-triggering item, the indicator light will be illuminated.
- 2) In case of sensor error, the indicator light will be lit in red.
- 3) When the sensor error is resolved, the indicator light will be lit in orange.

3.9.12 Battery Voltage

- Displays the battery voltage to inform you of the battery status.



[Fig. 3-29] Battery Voltage

- 1) If the engine stop status is maintained at 24V or higher for 3 seconds, the indicator light will be green. If it is below 23.9V, the indicator light will be red.
- 2) the engine start status is maintained at 25.5V or higher for 3 seconds, the indicator light will be green. If it is below 25V, the indicator light will be red, accompanied by a warning

3. Part Names, Operation and Settings

3.9.13 Engine Alarm

- When the coolant temperature, engine oil pressure, gearbox oil pressure, charging system, moisture detection, over-speed, fuel leakage, gearbox oil pressure, and battery voltage warning lights illuminate, an audible warning sound is triggered.



[Fig. 3-30] V-Type Engine Alarm



[Fig. 3-31] In-Line Engine Alarm

NO.	Alarm	Action Characteristics
①	COOLING WATER TEMP	<ul style="list-style-type: none"> When coolant high-temperature detection occurs or when the (In-Line) P2185/(V-Type) P02174B fault code is received, the warning light will start flashing and an audible warning sound will be emitted.
②	ENGINE OIL PRESS	<ul style="list-style-type: none"> When the (In-Line) P1521/(V-Type) P052484 fault code is received, the warning light will start flashing and an audible warning sound will be emitted.
③	OVER SPEED	<ul style="list-style-type: none"> When the (In-Line) P0219/(V-Type) P021985 fault code is received, the warning light will start flashing, and an audible warning sound will be emitted. When the Rate Speed exceeds 120%, the warning light will start flashing, an audible warning sound will be emitted, and the system will be shut down.
④	CHARGE	<ul style="list-style-type: none"> When the (In-Line) P0562/(V-Type) P0560A2 fault code is received, the battery charging warning light will start flashing, and an audible warning sound will be emitted.
⑤	CAN	<ul style="list-style-type: none"> When a CAN communication error occurs, the warning light will start flashing, and an audible warning sound will be emitted. When the (In-Line) B1002/(V-Type) B100200 fault code is received, a "CAN Communication Error" popup will appear.
⑥	WATER IN FUEL	<ul style="list-style-type: none"> When Water In Fuel detection conditions are maintained for 10 seconds (when the Water In Fuel sensor is activated), the warning light will start flashing, and an audible warning sound will be emitted.
⑦	FUEL LEAKAGE	<ul style="list-style-type: none"> After 10 seconds of fuel leakage detection, the warning light will start flashing, and an audible warning sound will be emitted (In-Line) B1005/(V-Type) B100500 When receiving fault code, "[Panel] Fuel Leak Detection" pop-up occurs

3. Part Names, Operation and Settings

⑧	GEARBOX OIL PRESSURE	<ul style="list-style-type: none"> · If the engine maintains a pressure below 1 bar for 10 seconds during operation, the warning light will flash, and an audible warning sound will be emitted. · If the engine maintains a pressure of 1.5 bar or above during operation, it will be indicated in green. · For In-Line engines, this information will be displayed on the gauge. Please refer to Page 15 for more details.
⑨	BATTERY VOLTAGE	<ul style="list-style-type: none"> · The display and audible warning sound will vary depending on the engine running or stopped status (refer to section 3.9.12 for details)

[Table 3-7] Warning light characteristics

3.9.14 Engine Stop

- 1) When the engine RPM exceeds 120% of the Rate Speed (Shutdown).
- 2) If the current RPM is not received via CAN for 5 seconds during engine operation.
- 3) When the Emergency button is pressed.
- 4) In the event of fuel leakage.

※ How to turn off the engine warning light

- When the alarm condition is cleared and it is maintained for 3 seconds, the buzzer and lamp are automatically released and the lamp changes to orange

3. Part Names, Operation and Settings

3.10 Other status

- It represents various states of the engine and the PAGE key in the function keys enable it to move to the sub-pages.

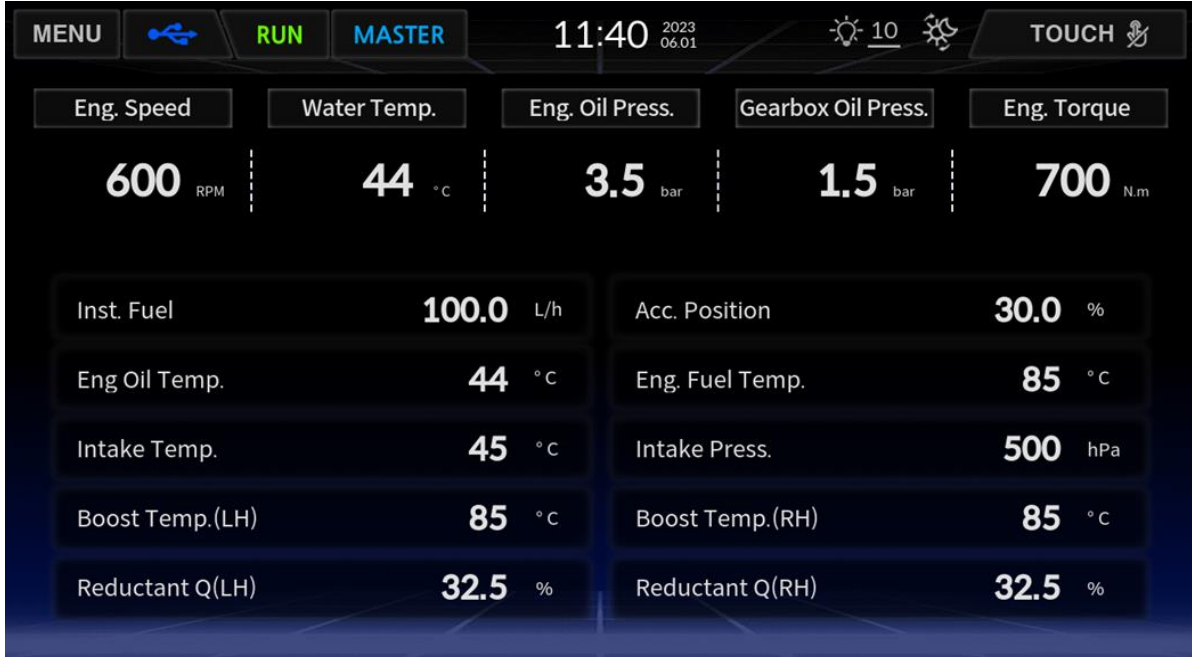

[Fig. 3-32] V-Type Engine Sub-Page Display Information

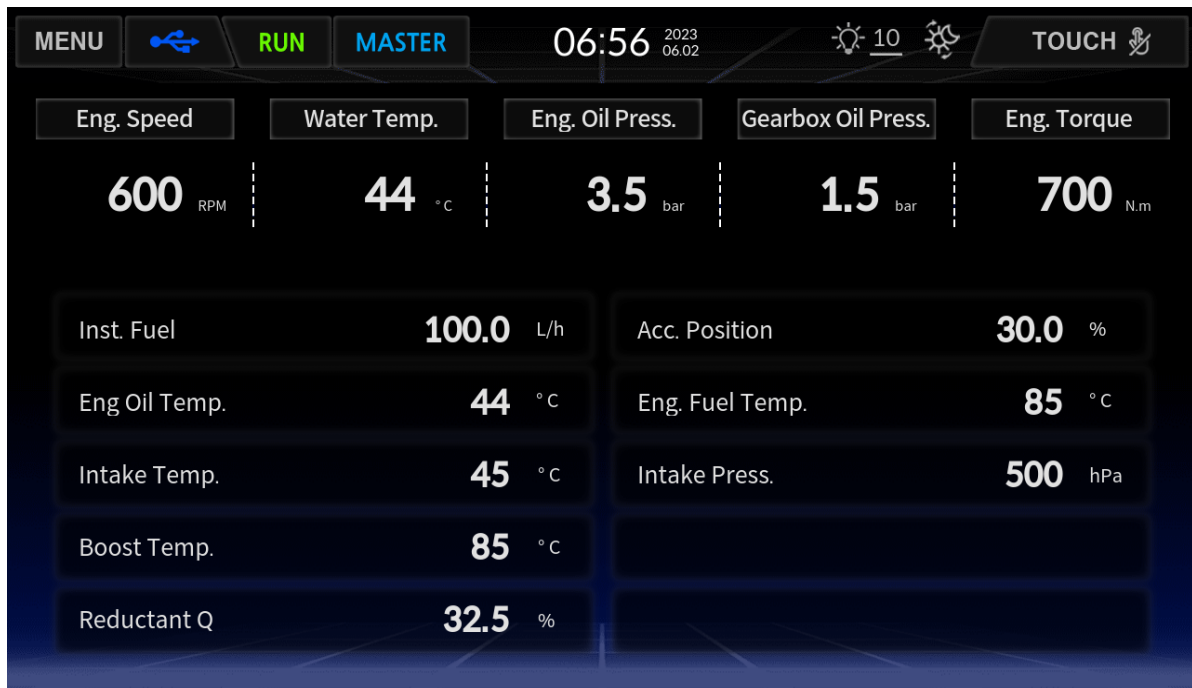

[Fig. 3-33] In-Line Engine Sub-Page Display Information

3. Part Names, Operation and Settings

Item (V-Type Engine)	Item (In-Line Engine)
Eng. Torque - (Nm) unit notation	Eng. Torque - (Nm) unit notation
Inst. Fuel - (L/h) unit notation	Inst. Fuel - (L/h) unit notation
Eng. Oil Temp - (°C) unit notation	Eng. Oil Temp - (°C) unit notation
Intake Temp - (°C) unit notation	Intake Temp - (°C) unit notation
Boost Temp(LH) - (°C) unit notation	Boost Temp - (°C) unit notation
Reductant Q(LH) - (%) unit notation	Reductant Q - (%) unit notation
Max. Torque - (Nm) unit notation	Max. Torque - (Nm) unit notation
Eng. Fuel Temp - (°C) unit notation	Eng. Fuel Temp - (°C) unit notation
Intake Press - (hPa) unit notation	Intake Press - (hPa) unit notation
Boost Temp(RH) - (°C) unit notation	
Reductant Q(RH) - (%) unit notation	

[Table 3-8] Sub-Page Display Items

3. Part Names, Operation and Settings

3.11 Current Fault Information Page

- While the engine is running, the ECU detects any abnormalities in the engine and, when a fault condition occurs, transmits the fault code via CAN communication. This fault code is received by the digital panel, and the fault code and description are displayed on the monitor as shown in [Fig. 3-31].
- Over-speed (120% of rated speed), CAN communication error, water in fuel, fuel leakage, and other faults are detected by the digital panel, triggering pop-up notifications.
- Up to 20 real -time fault messages are displayed, as shown in [Fig. 3-34].
- The fault code alarm window shown in [Fig. 3-35] is displayed on the screen whenever a fault code occurs, regardless of which page the user is working on.
- V-Type engines display the fault codes with 7 digits, while In-Line engines display them with 5 digits.

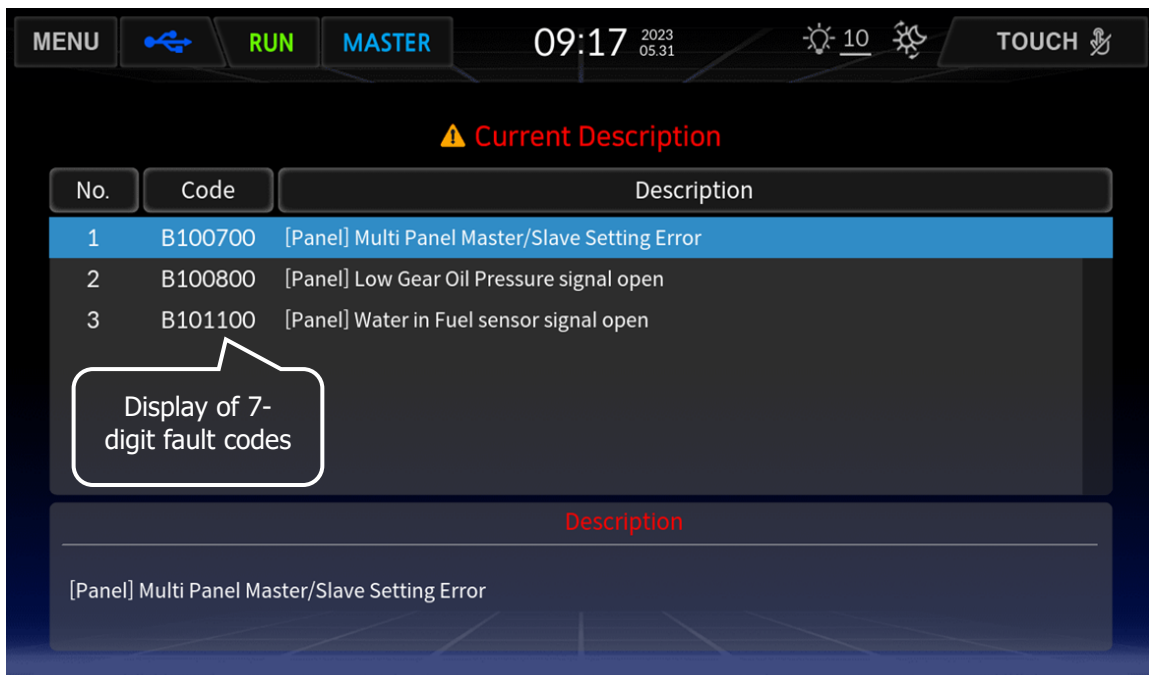

[Fig. 3-34] Current Fault Information Page

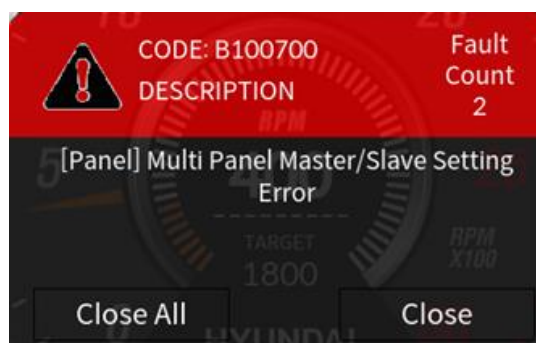

[Fig. 3-35] Fault Code Alarm Pop up

3. Part Names, Operation and Settings

3.12 Alarm Page

- It displays information about the number of engine starts, engine stops, engine abnormal stops, emergency starts, emergency stops, cumulative sensor alarm occurrences, and the date of the most recent alarm occurrence, all stored within the digital panel itself.
- Pressing the page buttons on the alarm screen will transit the display to the main page.
- V-Type engines display fault codes with 7 digits, while In-Line engines display fault codes with 5 digits.

Code	Description	OC	Alarm Date
B1004	[Panel] Low Gear Oil Pressure	0	-
B1006	[Panel] Water in Fuel Detection	0	-
P2185	High coolant temperature error (Alarm)	0	-
P1521	Low oil pressure error	0	-
P0219	Engine overspeed detection error	0	-
P0562	Low battery voltage error	0	-
P0251	Maximum positive deviation excess error of rail pressure (Fuel leakage)	0	-
P0181	High fuel temperature error	0	-
P0196	High oil temperature error	0	-
P043B	High SCR downstream temperature error	0	-
P0110	High boost temperature(Intercoler Downstream) error	0	-
P206C	Low DEF quality error	0	-
P103C	Low DEF tank level error	0	-

[Fig. 3-36] In-Line Engine Alarm Page Screen

5-digit display

In-Line Engine Alarm Page List			
B1004	[Panel] Low Gear Oil Pressure	P0181	High fuel temperature error
B1006	[Panel] Water In Fuel Detection	P0196	High oil temperature error
P2185	High coolant temperature error (Alarm)	P043B	High SCR downstream temperature error
P1521	Low oil pressure error	P0110	High boost temperature
P0219	Engine overspeed detection error	P206C	Low DEF quality error
P0562	Low battery voltage error	P103C	Low DEF tank level error
P0251	Maximum positive deviation excess error of rail pressure (Fuel leakage)		

[Table 3-9] In-Line Engine Alarm Page List

3. Part Names, Operation and Settings

Code	Description	OC	Alarm Date
B100400	[Panel] Low Gear Oil Pressure	0	-
B100600	[Panel] Water in Fuel Detection	0	-
P02174B	[ECU] High coolant temperature error (Alarm)	0	-
P052484	[ECU] Low oil pressure error	0	-
P021985	[ECU] Engine overspeed detection error	0	-
P0560A2	[ECU] Low battery voltage error	0	-
P00017A	[ECU] Maximum positive deviation excess error of rail pressure(Fuel leakage) (RH bank)	0	-
P016885	[ECU] High fuel temperature error	0	-
P052085	[ECU] High oil temperature error	0	-
P042585	[DCU (RH)] Diagnostic Fault Check for Physical Signal above maximum temperature limit for SCR downstream	0	-
P043585	[DCU (LH)] Diagnostic Fault Check for Physical Signal above maximum temperature limit for SCR downstream	0	-
P007A85	[ECU] CAC upstream temperature high error of RH bank	0	-
P00A085	[ECU] CAC upstream temperature high error of LH bank	0	-

7-digit display

[Fig. 3-37] V-Type Engine Alarm Page Summary Screen

V-Type Engine Alarm Page List			
B100400	[Panel] Low Gear Oil Pressure	P042585	[DCU (RH)] Diagnostic Fault Check for Physical Signal above maximum temperature limit for SCR downstream
B100600	[Panel] Water in Fuel Detection	P043585	[DCU (LH)] Diagnostic Fault Check for Physical Signal above maximum temperature limit for SCR downstream
P02174B	[ECU] High coolant temperature error (Alarm)	P007A85	[ECU] CAC upstream temperature high error of RH bank
P052484	[ECU] Low oil pressure error	P00A085	[ECU] CAC upstream temperature high error of LH bank
P021985	[ECU] Engine overspeed detection error	P207F84	[DCU (RH)] Diagnostic fault check for "physical signal below minimum limit" (DEF quality)
P0560A2	[ECU] Low battery voltage error	P32E984	[DCU (LH)] Diagnostic fault check for "physical signal below minimum limit" (DEF quality)
P00017A	[ECU] Maximum positive deviation excess error of rail pressure(Fuel leakage) (RH bank)	P203F00	[DCU (RH)] Status of tank level is empty
P016885	[ECU] High fuel temperature error	P32B900	[DCU (LH)] Status of tank level is empty
P052085	[ECU] High oil temperature error		

[Table 3-10] V-Type Engine Alarm Page List

3. Part Names, Operation and Settings

3.13 System Booting and Functional Check

- After installing the product, check to see if it has been installed properly

▶ Normal System Booting

- 1) After inserting the key into the key switch, if the key is rotated in the ON direction (right), it returns to the central point and is fixed.
- 2) HYUNDAI logo is displayed when the system is booted [Fig. 3-39]
 - ※ In case, the screen is not output when the key is rotated
 - Key OFF and then ON again
 - Check the harness connection behind the panel
 - Check for battery discharge
- 3) After booting normally, the gauge screen appears.[Fig. 3-40]
 - Gauge : Check that each gauge needle is within the normal range and check if it is displayed on the 'OPEN' or 'SHORT' screen
 - ※ When 'OPEN' or 'SHORT' occurs
 - Check the harness connection status
 - Function keys: Check whether each function key is operated normally
 - Warning light: Check if the warning light is on
 - Battery: Check if the battery voltage is normal
- 4) If there is no problem in the initial gauge screen, turn the key to start the engine.
- 5) Check RPM operation (initially 400RPM or higher, oil pressure 1bar or higher) and warning light on (red lamp blinks when warning light is on)

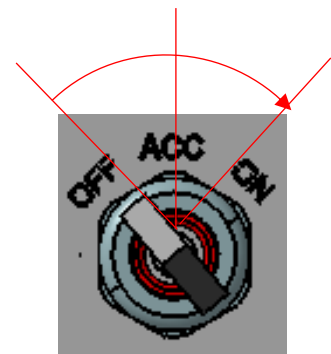

[Fig. 3-38] Key Switch



[Fig. 3-39] Boot Logo



[Fig. 3-40] Gauge Screen

4. Multi Panel Structure

4.1 Multi Panel

- It is possible to install up to 3 additional units except for the Master in the vessel, and it is possible to check and control the vessel status at any time depending on the setting. (However, be careful of the battery voltage drops as the length of the harness increases.)

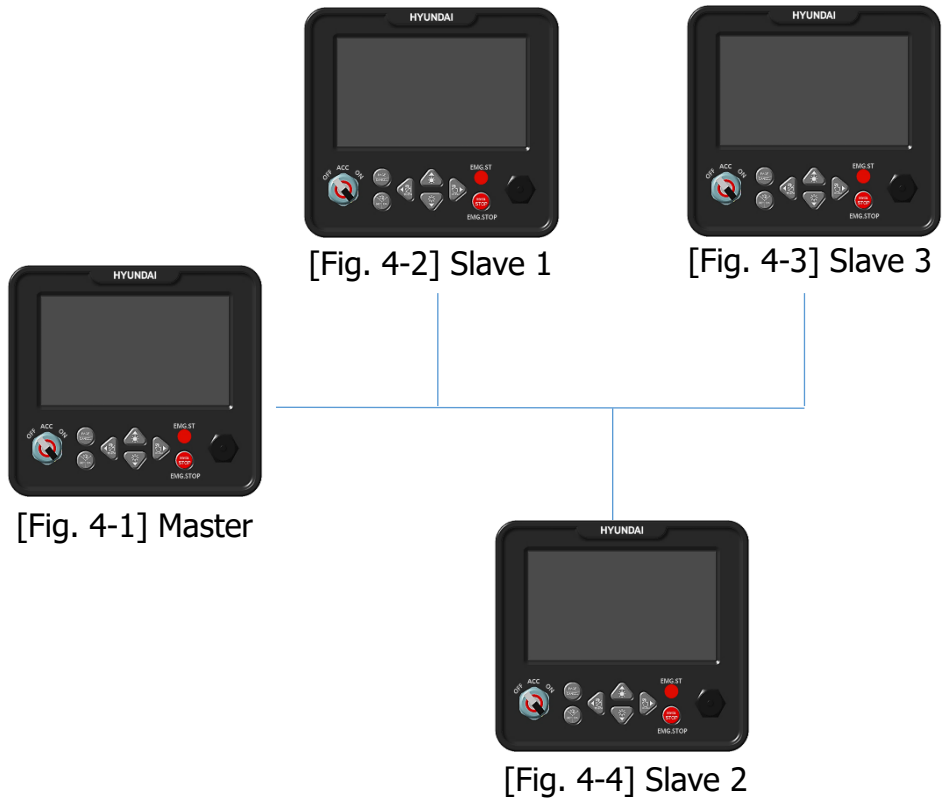

4. Multi Panel Structure

4.2 How to Install Multi Panel

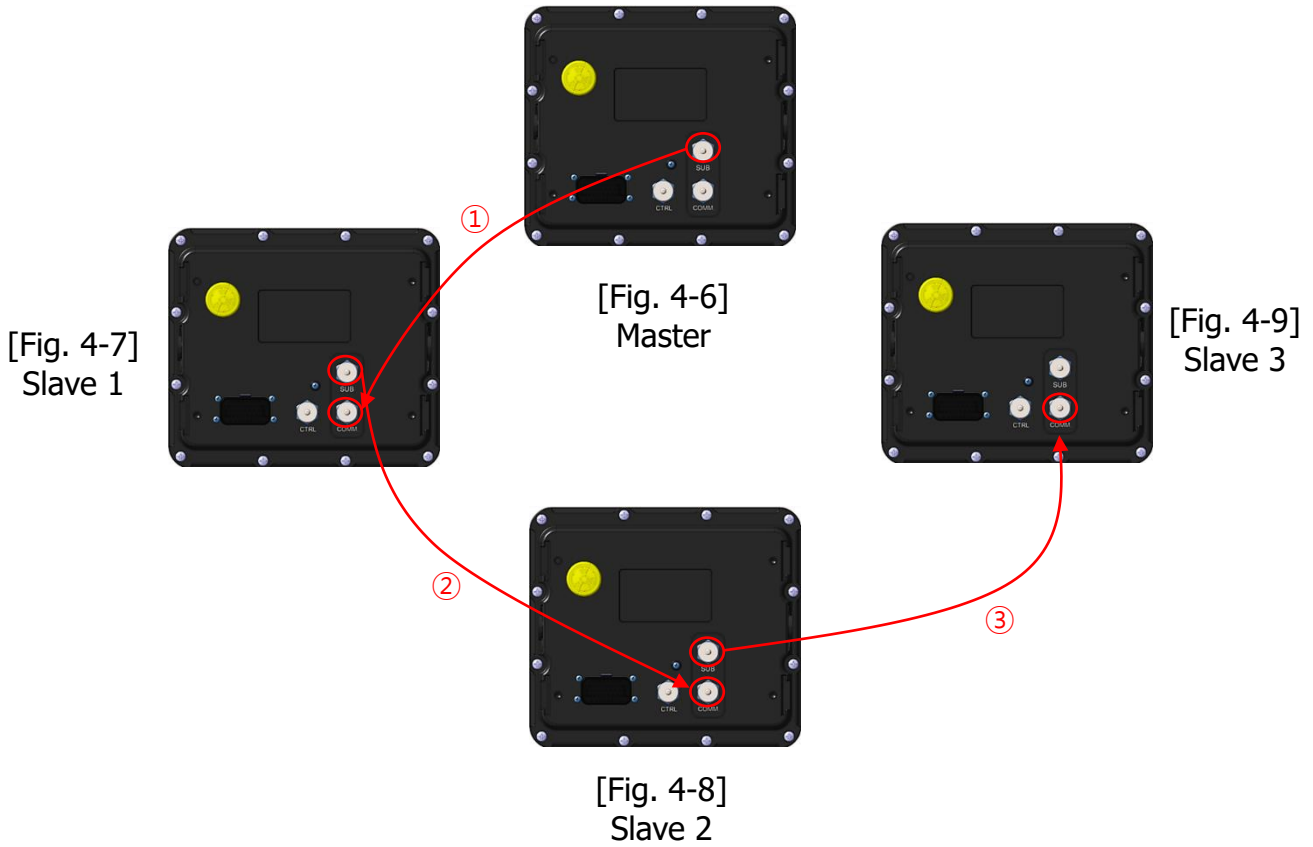

※ Before installing the multi-panel, the necessary cables should already be prepared.
(Cables should use HD Hyundai InfraCore recommended specifications)

- (1) Connect the SUB terminal of the Master panel to the main connector terminal of the Slave 1 panel as shown in ①. (2 panels)
 - Master and Slave 1 connection completed
- (2) In the state connected as in ① above, as in ②, that is, connect Slave1(COMM) to Slave2(SUB). (3 panels)

4. Multi Panel Structure

4.3 Multi Panel Setting

- (1) Press and hold the OK button of the panel to be set in Slave mode for 3 seconds.
- (2) When the Settings window opens, navigate to Figure ① (Use the directional keys to navigate).
- (3) Press the OK button to switch between Master / Slave1 / Slave2 / Slave3.
 - ※ Note: When connecting multiple Slaves, the Slave mode settings should not overlap.
- (4) Set the panel to Master mode using the same method as above.

※ Note

- Only one product can be set in Master mode, and up to two Slaves are recommended.
- If the cable length between Master and Slaves is more than 30m, there may be a voltage drop of more than 1V, so it needs to be checked.
- Granting engine start permission to Slave panels can only be done from the Master panel.
 - In the "Remote Engine Start" menu of the Master panel, select the Slave to grant engine start permission
 - When granting engine start permission to a Slave, the Master loses its own engine start permission.
 - Panels with engine start permission are indicated by colored icons on the indicator [Fig. 4-10 ②][Fig. 4-12].
- When a panel without engine start permission attempts to start the engine, a "No engine start permission" popup appears [Fig. 4-11].
- If both Master and Slave panels have duplicated settings for Local/Remote (e.g., Master, Master), a "[Panel] Multi Panel Local/Remote Setting Error" popup appears [Fig. 4-13].
- Emergency engine start is only possible from the Master panel, and emergency engine stop is possible from any Slave.
 - Slave emergency engine stop operates via CAN communication.
- Re-engaging the starter is not possible during engine operation (except for Emergency Start from the Master panel)



[Fig. 4-10] Multi Panel Settings Pop-up

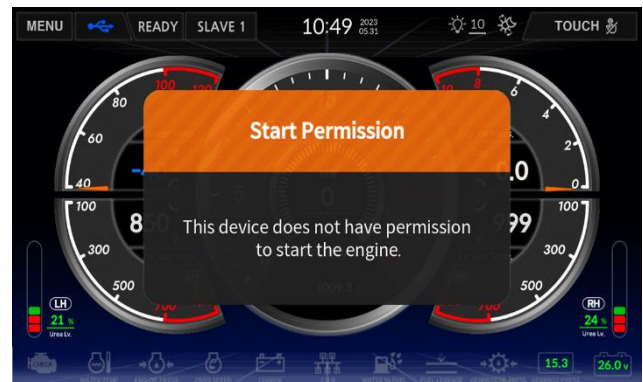

[Fig. 4-11] Engine Start Authorization Pop-up

4. Multi Panel Structure

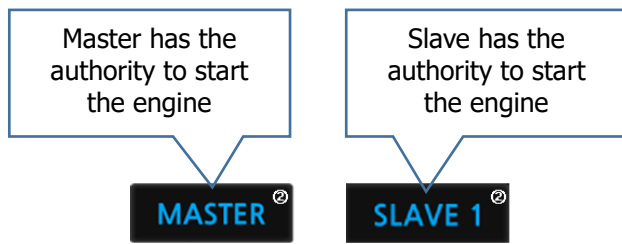

[Fig. 4-12] Master/Slave Start Authorization



[Fig. 4-13] Multi Panel Settings Error

5. Maintenance

5.1 Maintenance

- To maintain the performance of the device, regular maintenance is required.
- 1. Use soft cloth to clean the LCD without damaging it.
 - 1) Clean the LCD after turning the power off.
 - 2) Do not use cleaners with acids or ammonia.
 - 3) Do not use neutral detergents to remove oil stains.
 - 4) Use cloth slightly wet with clean water to remove salt residuals or dust particles for natural drying. If there remain stains, clean them with soft cloth (microfibers) once again.
- 2. Check whether the connectors or harnesses at the back of the device are properly connected or whether they have dust or other foreign substances.
- 3. Check whether cables are damaged.
- 4. Request for checking when the software needs upgrade as follows:
 - When the manufacturer releases official software for performance improvements

5.2 Troubleshooting

- It describes possible measures for users to resolve problems while using the device
- 1. The device is not turned on.
 - 1) Check whether harness cables at the back of the product are properly connected.
 - 2) Where harness cables have too much dust or moisture, remove them and clean the dust or moisture. Connect them once again after a while.
 - 3) Check whether the fuse button at the back of the product is pulled out.
 - 4) Check whether the battery is discharged.
- 2. You can see lines or shaking on the screen.
 - 1) Reboot the product.
 - 2) As the LCD is connected inside the product, do not disassemble it and contact the service team.
- 3. You can see alarm or hear warning beeps at the bottom of the product screen.
 - 1) Check where the alarm occurs and then take measures as necessary (if you need to confirm which alarm occurs, refer to Page 20 of this manual).
- 4. You cannot control buttons.
 - 1) Check whether there are foreign substances at the panel buttons.
 - 2) As the button connecting parts may be damaged, do not disassemble the product and contact the service team.

6. Warranty and A/S Service

6.1 Warranty

- As this manual contains important contents related to safety, use and maintenance of the product. So please read this manual carefully and then use the product in a proper manner.

Those who are not familiar with the product should keep this manual close to themselves.

We are not responsible for human injuries or property damages caused by the following reasons:

- Where you use the product for purposes other than the ones described in this manual
- Where you alter the product or its components at discretion
- Where you disassemble the product at discretion to resolve problems
- Where you use accessories or parts not supplied or recommended by us
- ※ Where you use accessories or parts manufactured by other companies, please contact our service

6.2 A/S Service Information

- When you request A/S service, please let us know the model name, breakdown conditions and your contact information.
- Please ask the seller.