

# Operation & Maintenance Manual

**GAS GENERATOR ENGINE**

**GE08TIC**

















## FOREWORD

This manual is designed to serve as a reference for HD Hyundai Infracore customers and distributors who wish to gain basic product knowledge on HD Hyundai Infracore **GE08TIC** compressed natural gas engines.

These economical and high-performance natural gas engines (6 cylinders, 4 strokes, in-line type) have been so designed and manufactured to be used for the generator application. They meet all the requirements such as low noise, fuel economy, high engine speed and durability.

To maintain the engine in optimum condition and retain maximum performance for a long time, **CORRECT OPERATION** and **PROPER MAINTENANCE** are essential.

In this manual, the following symbols are used to indicate the type of service operations to be performed.

	Removal		Adjustment
	Installation		Cleaning
	Disassembly		Pay close attention-Important
	Reassembly		Tighten to specified torque
	Align the marks		Use special tools of manufacturer's
	Directional Indication		Lubricate with oil
	Inspection		Lubricate with grease
	Measurement		

During engine maintenance, please observe following instructions to prevent environmental damage;

- Take old oil to an old oil disposal point only.
- Ensure without fail that oil will not get into the sea or rivers and canals or the ground.
- Treat undiluted anti-corrosion agents, antifreeze agents, filter element and cartridges as special waste.
- The regulations of the relevant local authorities are to be observed for the disposal of spent coolants and special waste.

If you have any question or recommendation in connection with this manual, please do not hesitate to contact our head office, dealers or authorized service shops near by your location for any services.

For the last, the content of this maintenance instruction may be changed without notice for some quality improvement. Thank you.

- \* Items exempted from warranty coverage
  - Malfunctions resulting from failing to comply with the proper handling instructions, regular inspections, and machine storage techniques specified in the user manual
  - Malfunctions resulting from failing to have the machine repaired at a designated dealer or center, or resulting from the use of non-genuine parts
  - Malfunctions resulting from unauthorized modifications, changes, or external hardware
  - Malfunctions resulting from incorrect operation by the user, delayed repairs, accidents, and natural disasters
  
- \* The contents of this operation and maintenance manual are the exclusive property of HD Hyundai Infracore. Any unauthorized reproduction, printing and distribution thereof are strictly prohibited.

# CONTENTS

<b>1. Safety Regulations &amp; Engine Specifications</b> .....	<b>1</b>
1.1. General notes .....	1
1.2. Handle compressed natural gas safety .....	1
1.3. General information .....	7
1.4. Engine assembly .....	9
<b>2. Technical Information</b> .....	<b>12</b>
2.1. Engine model and serial number .....	12
2.2. Engine characteristic .....	12
2.3. Diagnosis and remedy .....	28
2.4. Engine inspection .....	38
<b>3. Disassembly and Reassembly of Major Components</b> .....	<b>40</b>
3.1. Engine disassembly .....	40
3.2. Inspection and measurement on major parts .....	53
3.3. Engine reassembly .....	74
3.4. Electrical system .....	101
3.5. Speed controller .....	104
3.6. Ignition controller .....	106
3.7. Ignition control module .....	109
3.8. Speed controller setting .....	114
<b>4. Commissioning and Operation</b> .....	<b>119</b>
4.1. Operation preparation .....	119
4.2. Breaking-in .....	119
4.3. Inspections after starting .....	121
4.4. Operation in winter time .....	122
4.5. Tuning the engine .....	122
4.6. Maintenance and care .....	123
4.7. Cooling system .....	125
4.8. Adjustment of valve clearance .....	127
4.9. Tightening the cylinder head bolts .....	129
4.10. Cylinder compression pressure .....	130
4.11. Belts .....	131

**5. Maintenance of Major Components ..... 133**

- 5.1. Cooling system ..... 133
- 5.2. Lubricating system ..... 136
- 5.3. Turbocharger ..... 140
- 5.4. Air intake system ..... 148

# 1. Safety Regulations & Engine Specifications

## 1.1. General notes

Day-to-day use of power engines and the service products necessary for running them presents no problems if the persons occupied with their operation, maintenance and care are given suitable training and think as they work.

This summary is a compilation of the most important regulations. These are broken down into main sections which contain the information necessary for preventing injury to persons, damage to property and pollution. In addition to these regulations those dictated by the type of engine and its site are to be observed also.



### **IMPORTANT:**

**If despite all precautions, an accident occurs, in particular through contact with caustic acids, fuel penetrating the skin, scalding from oil, antifreeze being splashed in the eyes etc, consult a doctor immediately.**

## 1.2. Handle compressed natural gas safety

Natural gas is highly flammable and explosive and may be extremely cold. The following cautions must be taken to avoid personal injury or engine damage.

- Do not smoke when installing or servicing the engine or fuel system.
- Installation or servicing of natural gas equipment must only be conducted in well ventilated, natural gas compatible areas. Do not install or service equipment in an enclosed area where ignition sources are present without ensuring that an undetected gas leak may be safely vented without being ignited.
- Do not vent natural gas or permit leaks inside an enclosed area.  
Bleed natural gas lines before installing or servicing any component connected to the fuel lines.



### 1.2.1. Avoid heating near pressurized fluid lines

- Wear welding goggles and gloves when welding or using an acetylene torch.
- Insure a that metal shield separated the acetylene and oxygen which must be chained to a cart.
- Do not weld or heat areas near fuel tanks or fuel lines.



### 1.2.2. Venting an operable engine to relieve natural gas pressure

- To avoid personal injury an operable natural gas engine must be kept in a well ventilated area away from open flames and sparks.
- If the engine can run, use the following venting procedure to relive the natural gas pressure downstream of the shutoff valve.

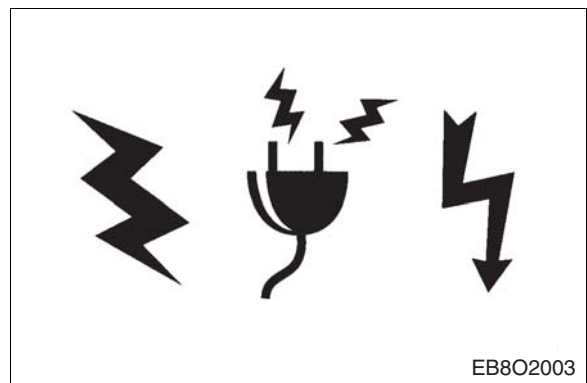

- 1) Shut off manual valves on natural gas supply lines and main shutoff valve on natural gas fuel supply line.
- 2) Start engine and run until it stalls due to fuel starvation.
- 3) Check to make sure gauge pressure at point on the natural gas fuel line to be vented has been reduced to zero. If not, repeat step 1) Then repeat step 2).
- 4) Disconnect engine batteries using switch in battery compartment or by disconnecting battery ground cable.
- 5) Slightly loosen the NG fuel line fitting to be serviced in a well ventilated area to allow any remaining gas to vent.
- 6) Completely open the fitting that was slightly opened and allow to vent in a well ventilated area.

### 1.2.3. During commissioning, starting and operation



- This is the safety alert symbol. When you see this symbol in this manual, be alert to the potential for personal injury.



- Carefully read all safety message in this manual and on your engine safety signs. Be sure new equipment components and repair parts include the current safety signs.



- Avoid possible injury or death from vehicle runaway. Do not start engine by shorting across starter terminals. Vehicle will start in gear if normal circuitry is bypassed. Start engine only from operator's seat with transmission in neutral or park.



- Prevent fires by keeping machine clean of accumulated trash, grease, fuel and debris.
- When the engine is running, do not get too close to the rotating parts.



- Do not touch the engine with bare hands when it is warm from operation risk of burns.



- Exhaust gases are toxic. If it is necessary to run an engine in an enclosed area, remove the exhaust gases from the area with an exhaust pipe extension. If you do not have an exhaust pipe extension, open the doors and get outside air into the area.



- Keep vicinity of engine free of oil and grease. Accidents caused by slipping can have serious consequences.

#### 1.2.4. During maintenance and care



- Always carry out maintenance work when the engine is switched off. If the engine has to be maintained while it is running, e.g. changing the elements of change-over filters, remember that there is a risk of scalding. Do not get too close to rotating parts.
- Change the oil when the engine is warm from operation.



#### **CAUTION:**

**There is a rise of burns and scalding. Do not touch oil drain plug or oil filters with bare hands.**

- Take into account the amount of oil in the sump. Use a vessel of sufficient size to ensure that the oil will not overflow.
- Open the coolant circuit only when the engine has cooled down. If opening while the engine is still warm is unavoidable, comply with the instructions in the chapter "Maintenance and Care".
- Neither tighten up nor open pipes and hoses (lube oil circuit, coolant circuit and any additional hydraulic oil circuit) during the operation. The fluids which flow out can cause injury.



- Fuel is inflammable. Do not smoke or use naked lights in its vicinity.
- When using compressed air, e.g. for cleaning the radiator, wear goggles.



- Keep service products (anti-freeze) only in containers which can not be confused with drinks containers.
- Comply with the manufacturer's instructions when handling batteries.



#### **CAUTION:**

**Accumulator acid is toxic and caustic. Battery gases are explosive.**

### 1.2.5. When carrying out checking, setting and repair work

- Checking, setting and repair work must be carried out by authorized personnel only.
- Use only tools which are in satisfactory condition. Worn open-end wrench slip, which could lead to injury.
- When the engine is hanging on a crane, no-one must be allowed to stand or pass under it. Keep lifting gear in good condition.
- When working on parts which contain asbestos, comply with the notes at the end of this chapter.
- When working on the electrical system disconnect the battery earth cable first. Connect it up again last in prevent short circuits.



### 1.2.6. To prevent damage to engine and premature wear

- (1) Never demand more of the engine than it was designed to yield for its intended purpose.
- (2) If faults occur, find the cause immediately and have it eliminated in order to prevent more serious of damage.
- (3) Use only genuine HD Hyundai Infracore spare parts. HD Hyundai Infracore will accept no responsibility for damage resulting from the installation of other parts which are supposedly "just as good".
- (4) In addition to the above, note the following points.
  - Never let the engine run when dry, i.e. without lube oil or coolant.
  - Use only HD Hyundai Infracore approved service products (engine oil, anti-freeze and anticorrosion agent).
  - Pay attention to cleanliness. The Natural gas must be free of water. See "Maintenance and care"
  - Have the engine maintained at the specified intervals.
  - Do not switch off the engine immediately when it is warm, but let it run without load for about 5 minutes so that temperature equalization can take place.
  - Never put cold coolant into an overheated engine. See "Maintenance and care".
  - Do not add so much engine oil that the oil level rises above the max. marking on the dipstick. Do not exceed the maximum permissible tilt of the engine. Serious damage to the engine may result if these instructions are not adhered to.
  - Always ensure that the testing and monitoring equipment (for battery charge, oil pressure, coolant temperature) function satisfactorily.
  - Comply with instructions for operation of the alternator. See "Commissioning and operation".
  - Do not let the raw water pump run dry, If there is a risk of frost, drain the pump when the engine is switched off.
- (5) Keep no-load operation to a minimum. During no-load operation combustion chamber temperatures drop to the point where fuel does not burn completely, causing slobbering and white smoke. Always have some load connected when the gen set is run for long periods.

### 1.2.7. To prevent pollution

#### (1) Engine oil, filter elements, fuel filters

- Take old oil only to an oil collection point.
- Take strict precautions to ensure that oil does not get into the drains or into the ground. The drinking water supply could be contaminated.
- Filter elements are classed as dangerous waste and must be treated as such.

#### (2) Coolant

- Treat undiluted anti-corrosion agent and / or antifreeze as dangerous waste.
- When disposing of spent coolant comply with the regulations of the relevant local authorities.

#### (3) Cold Start

- The preheat lamp turns on when the key switch is set to "ON." When the preheat lamp goes off, proceed as follows. The preheater device activates when the coolant temperature is below 25°C, and the preheating system is automatically adjusted based on the coolant temperature. (The max. preheating time is around 25 seconds) It does not activate when the coolant temperature is over 25°C.



#### **CAUTION:**

**The engine is equipped with a preheating system for enhancing cold start ability.**

- In order to start the engine after the preheat lamp turns off, turn the key switch to the ignition position. When the key switch is turned to the ignition position, the pre-heater plug or air heater runs continuously to make starting the engine easier and reduce white exhaust gas. If the coolant temperature is over 25°C, it is not necessary to operate the pre-heater plug or air heater
- When the engine starts, set the key switch in the ON position. The timer runs for another 5 minutes even after the engine starts to heat the intake air and quickly eliminate white exhaust gas.



#### **CAUTION:**

**Do not run the start motor for over 10 seconds. If the engine still cannot be started after preheating, wait for 30 seconds and then perform preheating again before the second attempt to start the engine.**

### 1.2.8. Notes on safety in handling used engine oil

Prolonged or repeated contact between the skin and any kind of engine oil decreases the skin. Drying, irritation or inflammation of the skin may therefore occur. Used engine oil also contains dangerous substances which have caused skin cancer in animal experiments. If the basic rules of hygiene and health and safety at work are observed, health risks are not to the expected as a result of handling used engine oil



#### **Health precautions:**

- Avoid prolonged or repeated skin contact with used engine oil.
- Protect your skin by means of suitable agents (creams etc.) or wear protective gloves.
- Clean skin which has been in contact with engine oil.

- Wash thoroughly with soap and water, A nailbrush is an effective aid.
- Certain products make it easier to clean your hands.
- Do not use petrol, Diesel fuel, gas oil, thinners or solvents as washing agents.
- After washing apply a fatty skin cream to the skin.
- Change oil-soaked clothing and shoes.
- Do not put oily rags into your pockets.



**Ensure that used engine oil is disposed of properly.**

**- Engine oil can endanger the water supply -**

For this reason do not let engine oil get into the ground, waterways, the drains or the sewers. Violations are punishable.

Collect and dispose of used engine oil carefully. For information on collection points please contact the seller, the supplier or the local authorities.



**CAUTION:**

**Do not spray high-pressure water directly on the engine. It may damage engine parts, electronic parts, and wiring.**

**1.2.9. General repair instructions**



1. Before performing service operation, disconnect the grounding cable from the battery for reducing the chance of cable damage and burning due to short-circuiting.
2. Use covers for preventing the components from damage or pollution.
3. Engine oil and anti-freeze solution must be handled with reasonable care as they cause paint damage.
4. The use of proper tools and special tools where specified is important to efficient and reliable service operation.
5. Use genuine HD Hyundai Infracore parts necessarily.
6. Used cotter pins, gaskets, O-rings, oil seals, lock washer and self-lock nuts should be discarded and new ones should be prepared for installation as normal function of the parts can not be maintained if these parts are reused.
7. To facilitate proper and smooth reassemble operation, keep disassembled parts neatly in groups. Keeping fixing bolts and nut separate is very important as they vary in hardness and design depending on position of installation.
8. Clean the parts before inspection or reassembly. Also clean oil ports, etc. using compressed air to make certain they are free from restrictions.
9. Lubricate rotating and sliding faces of parts with oil or grease before installation.
10. When necessary, use a sealer on gaskets to prevent leakage.
11. Carefully observe all specifications for bolts and nuts torques.
12. When service operation is completed, make a final check to be sure service has been done property.

### 1.3. General information

#### 1.3.1. Engine Specifications

Items		Engine model	GE08TIC
Engine type			Water-cooled, 4 cycle in-line type Turbocharged & intercooled
Ignition system			Spark ignition
Combustion chamber type			Stoichiometric, Premixed and spark ignited
Used fuel			NG(Natural gas)
Cylinder liner type			Replaceable dry liner
Timing gear system			Gear driven type
No. of piston ring			2 compression ring, 1 oil ring
No. of cylinder-bore x stroke		(mm)	6 - 111 x 139
Total piston displacement		(cc)	8,071
Compression ratio			10.6 : 1
Engine dimension (length x width x height)		(mm)	1,259 x 851 x 1,065
Engine weight		(kg)	750
Rotating direction (from flywheel)			Counter clockwise
Firing order			1 – 5 – 3 – 6 – 2 – 4
Fuel ignition timing (B.T.D.C static)			13°
Engine control system			Engine speed controller type
Compression pressure		(kg/cm <sup>2</sup> )	16 (at 200 rpm)
Valve clearance (at cold)	Intake valve	(mm)	0.4 ±0.05
	Exhaust valve	(mm)	0.4 ±0.05
Intake valve	Open at		16° (B.T.D.C)
	Close at		36° (A.B.D.C)
Exhaust valve	Open at		46° (B.B.D.C)
	Close at		14° (A.T.D.C)
Lubrication method			Full forced pressure feed type
Oil pump type			Gear type driven by crankshaft
Engine oil pressure	Low idle	(bar)	0.8 ~ 1.4
	High idle	(bar)	3.0 ~ 4.8
Oil filter type			Full-flow, cartridge type
Lubricating oil capacity (max./min.)		(lit)	23/17
Oil cooler type			Water cooled
Water pump			Impeller type driven by belt
Cooling Method			Forced circulation by centrifugal impeller pump
Cooling water capacity (engine only)		(lit)	13.7
Alternator voltage – capacity		(V - A)	24 – 45
Starting Motor voltage – output		(V - kW)	24 – 6.0
Fuel system	Carburetor		Impco 200 varifuel carburetor
	Gas regulator		RV61
	Max. inlet pressure		1.0 psi at the engine inlet
	Shut-off valve		Solenoid valve (24VDC)

Items		Engine model	GE08TIC
Ignition system	Spark plug		Woo jin 0.3 ~ 0.4 mm air gap
	Ignition controller		Altronic CD-1 or CD-200 unit
	Ignition coil		One coil per cylinder
	Trigger system		Magnetic pick-up sensor and trigger wheel
Turbocharger	Model		HX35G
	Type		Water cooled, Exhaust gas driven
	Exhaust temperature		Max : 720°C

### 1.3.2. Engine Power

Production tolerance : ±5%

Engine model		Performance		
		Stand by	Prime	Continuous
GE08TIC	50Hz (1,500 rpm)	141 kW (192 PS)	128 kW (174 PS)	115 kW (156 PS)
	60Hz (1,800 rpm)	165 kW (224 PS)	150 kW (204 PS)	135 kW (184 PS)

**Note :** All data are based on operation without cooling fan at ISO 3046.

## 1.4. Engine assembly

**Note :** The images shown represent the standard model; they do not include all models.

### 1.4.1. Engine sectional view (longitudinal)

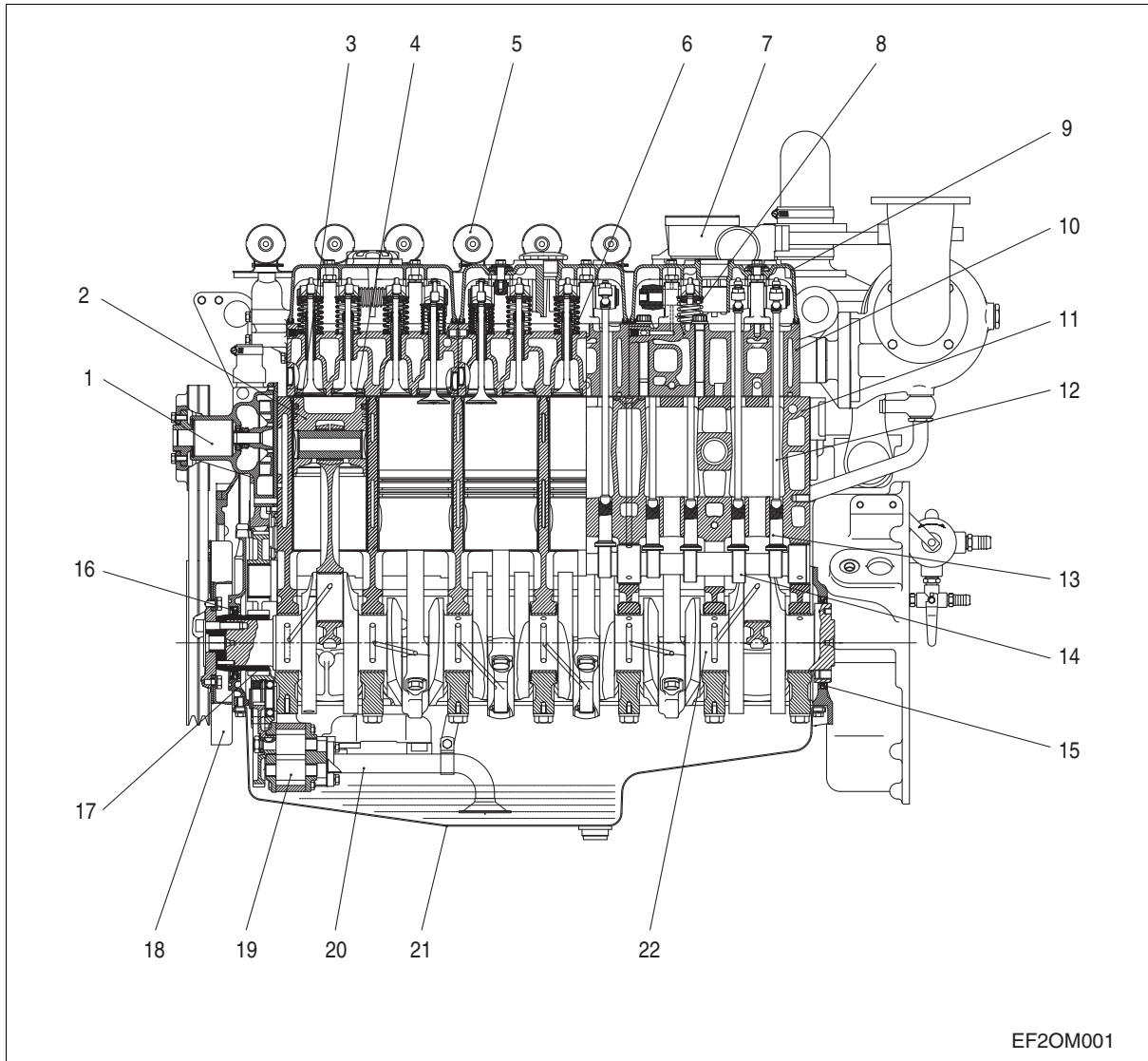

- |                         |                      |
|-------------------------|----------------------|
| 1. Cooling water pump   | 12. Push rod         |
| 2. Piston               | 13. Tappet           |
| 3. Exhaust valve        | 14. Camshaft         |
| 4. Intake valve         | 15. Oil seal(rear)   |
| 5. Ignition coil        | 16. Oil seal(front)  |
| 6. Intake valve spring  | 17. Crank gear       |
| 7. Breather             | 18. Vibration damper |
| 8. Exhaust valve spring | 19. Oil pump         |
| 9. Cylinder head cover  | 20. Oil suction pipe |
| 10. Cylinder head       | 21. Oil pan          |
| 11. Cylinder block      | 22. Crankshaft       |

### 1.4.2. Engine sectional view (cross)

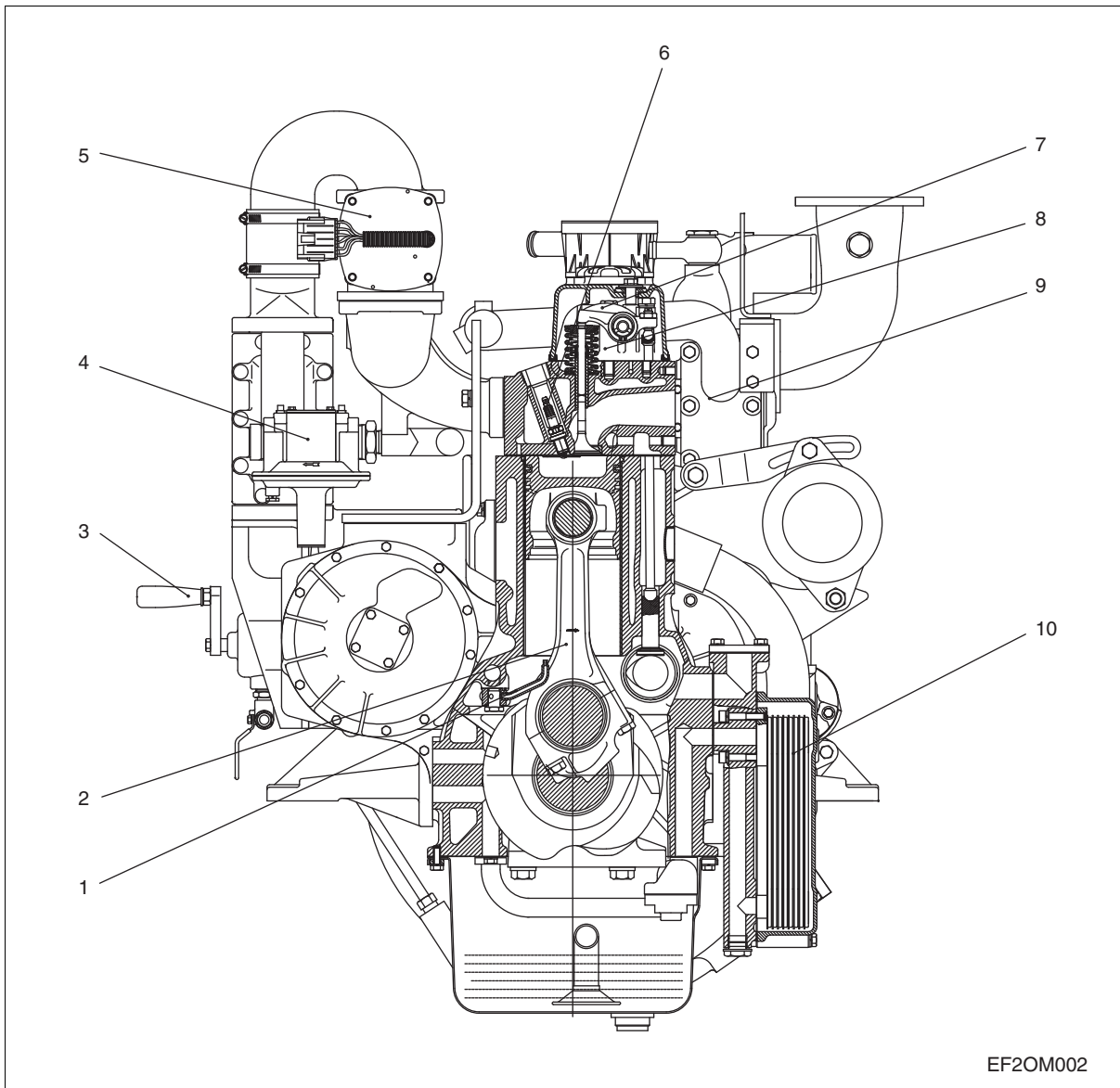

- 1. Oil spray nozzle
- 2. Connecting rod
- 3. Oil drain pump
- 4. Gas regulator
- 5. Throttle valve

- 6. Spark plug
- 7. Rocker arm
- 8. Rocker arm bracket
- 9. Exhaust manifold
- 10. Oil cooler

### 1.4.3. Engine assembly views

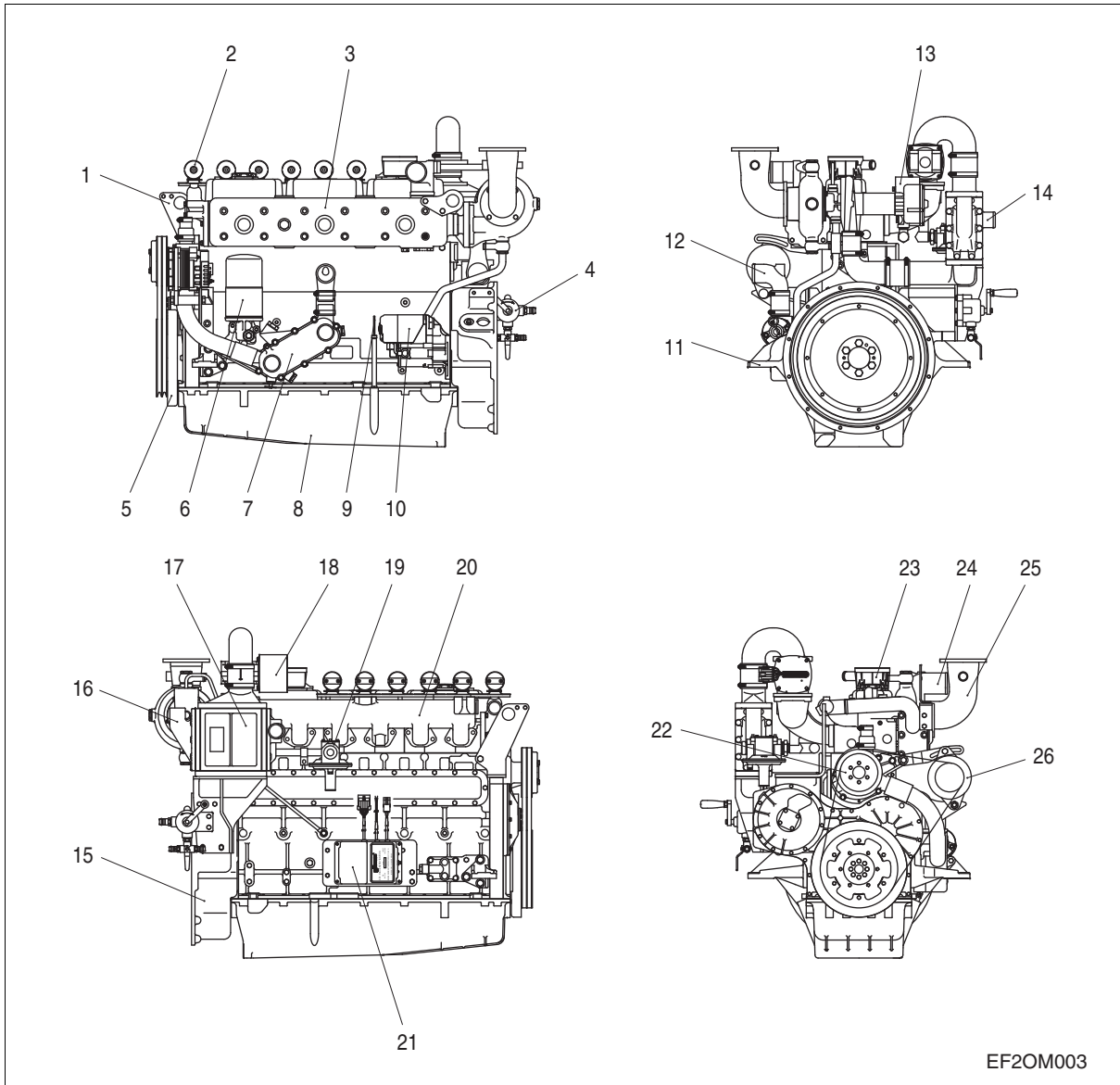

- |                                |                                   |
|--------------------------------|-----------------------------------|
| 1. Lifting hook                | 14. Water inlet(for Intercooler)  |
| 2. Ignition coil               | 15. Flywheel housing              |
| 3. Exhaust manifold            | 16. Water outlet(for Intercooler) |
| 4. Oil drain pump              | 17. Inter cooler                  |
| 5. Vibration damper            | 18. Throttle valve ass'y          |
| 6. Oil filter                  | 19. Gas regulator                 |
| 7. Oil cooler                  | 20. Intake manifold               |
| 8. Oil pan                     | 21. Ignition control module       |
| 9. Oil level gauge             | 22. Cooling water pump            |
| 10. Starter                    | 23. Breather                      |
| 11. Mounting bracket           | 24. Water outlet(by Water pump)   |
| 12. Water inlet(to oil cooler) | 25. Exhaust elbow                 |
| 13. Fuel mixer                 | 26. Alternator                    |

EF2OM003

## 2. Technical Information

### 2.1. Engine model and serial number

- The engine model and serial number is located on the engine as illustrated.
- These numbers are required when requesting warranty and ordering parts. They are also referred to as engine model and serial number because of their location.

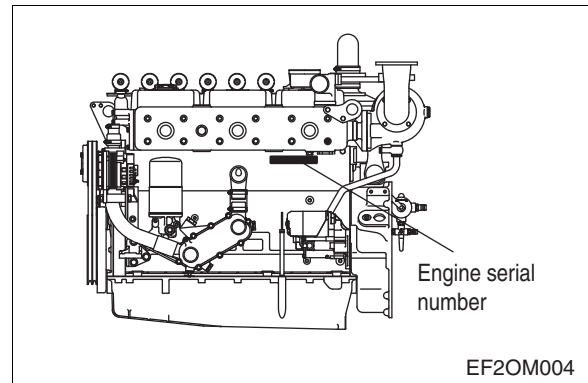

- Engine serial No. (GE08TIC)

EEPOD 5 00001

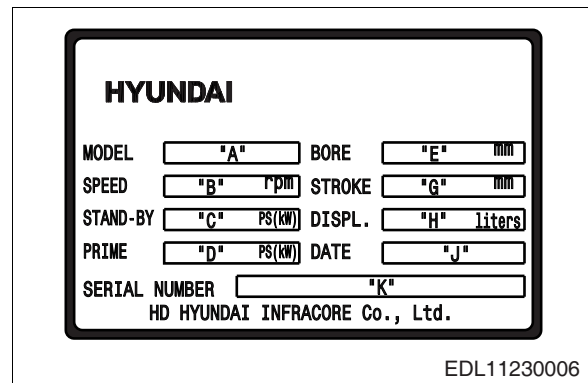
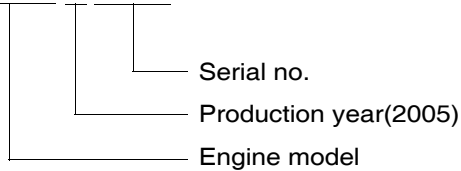

### 2.2. Engine characteristic

The HD Hyundai Infracore **GE08TIC** natural gas engine is an overhead valve, turbocharged, air-to-water charge cooled, electronically controlled engine.

#### 2.2.1. Natural gas

- Spark-ignited by the spark plug.
- Turbocharger with a water cooled bearing-housing.

#### 2.2.2. Natural gas

- Natural gas is a clean burning fuel, and offers a low particulate emission. Natural gas is also a very economical fuel.
- From the gas producing areas in the country, the distribution companies and local utilities from a complex nation-wide-delivery-network that supplies natural gas for home and industry use. The network is highly developed and extended to all major population center in the country.

### 2.2.3. Engine ignition system

- This system changes the general combustion concept of the diesel engine. Specifically, it changes a compression-ignition diesel to a spark-ignited engine. However, this engine is unlike the typical generator engine that has spark plugs.
- The primary difference is this system uses a combustion concept. That is, excess air is mixed in with the combustion system. When combined with a gaseous fuel like natural gas, it allows greatly reduced emissions compared to diesel, plus high efficiencies and excellent high-performance.
- The GE08TIC engine is an integrated package featuring computer-controlled electronic engine system by the engine speed controller. This system controls fuel, ignition and speed, and has engine protection features.

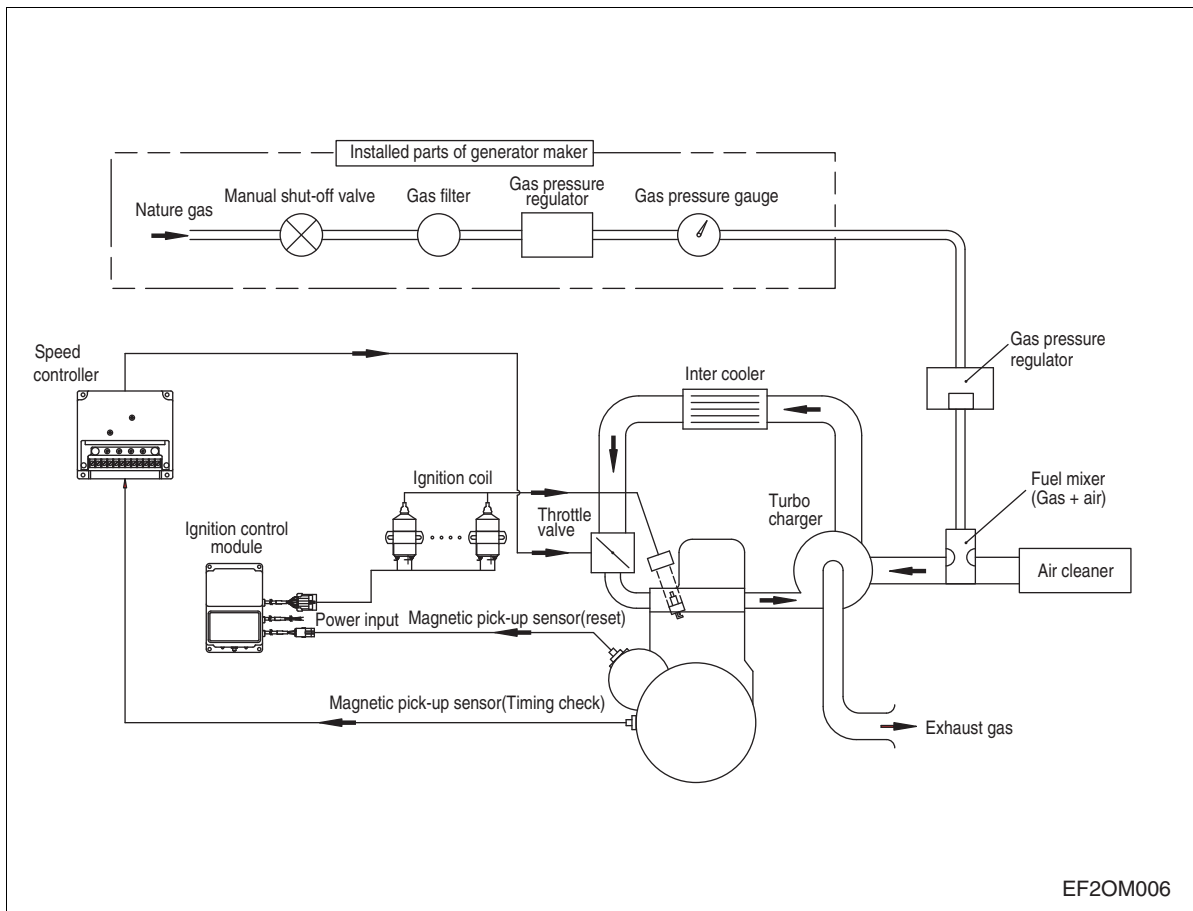

#### 2.2.4. Engine speed controller : ESC

- The Engine Speed Control is designed to provide basic isochronous speed control for gas engines using the Flo-Tech Throttle.
- Engines with mechanical loads and generator loads are handled equally well.

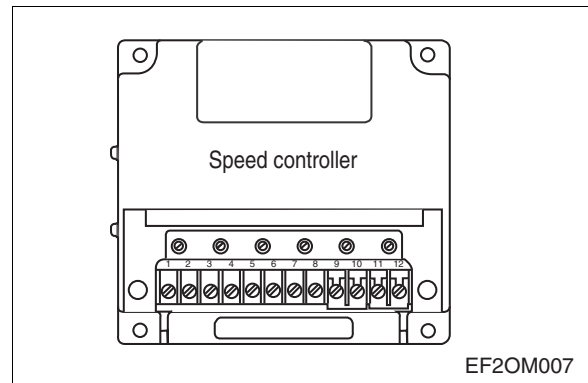

#### 2.2.5. Ignition control module : ICM

- This digital ignition system has been designed for application on nature gas fueled engines.
- This system offers a variety of advanced control, emissions reduction, primary and spark diagnostics, self diagnostic serial communications and engine protection features.

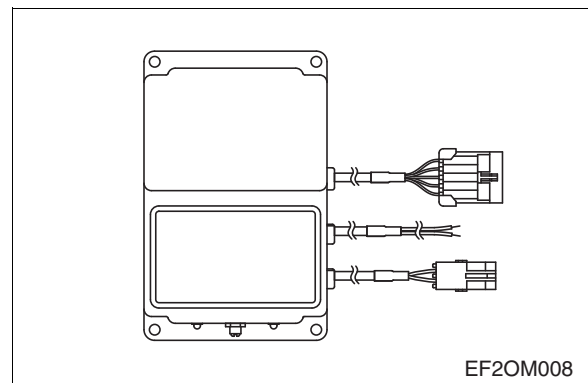

#### 2.2.6. Cylinder block

- The cylinder block is a single piece of alloy cast iron. To increase its stiffness, it is extended to a level below the crankshaft center line. The engine has replaceable dry cylinder liners and individual cylinder heads with struck-in valve seat rings and replaceable valve guides.

#### 2.2.7. Piston, con-rod and crankshaft

- The forged crankshaft is an ingrate type (Counterweight is integrated with crankshaft body). Radial oil seal on crankshaft and flywheel are provided to seal the flywheel housing inside penetrations.
- The con-rods (connecting rods) are die-forged, diagonally split and can be removed through the top of the cylinders together with the pistons. Crankshaft and connecting rods run in steel-backed lead bronze ready to fit type bearings.

## 2.2.8. Engine timing

- Camshaft, oil pump and ignition timing sensor gear are driven by a gear train arranged at the front end.

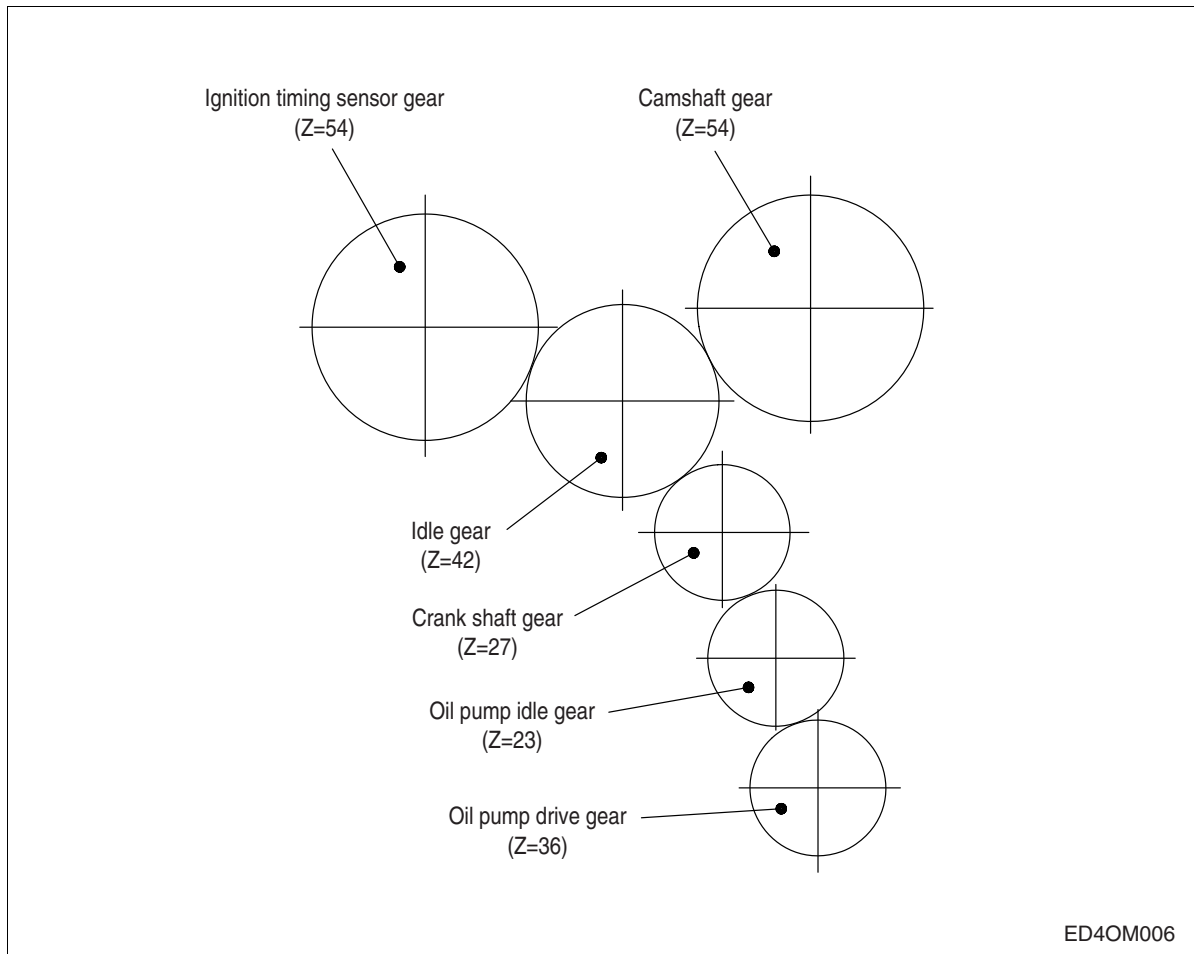

## 2.2.9. Valves

- The overhead valves are actuated via chilled cast iron tappets, push rods and rocker arms from the camshaft.

## 2.2.10. Lubrication system

- The engine is equipped with force-feed lubrication.

The pressure is produced by a gear pump whose drive gear is in direct mesh with the crankshaft gear at the front end of cylinder block.

- The oil pump draws the oil from the oil sump and delivers it through the oil cooler and oil filter to the main distributor gallery and from there to the main bearings, big-end bearings and camshaft bearings as well as to the small-end bearings and the rocker arms.
- The turbocharger is also connected to the engine lubricating system.  
The cylinder walls and timing gears are splash-lubricated.
- Each cylinder has an oil jet provided for cooling the underside of the pistons.
- The lube oil is cleaned in a full-flow oil filter.

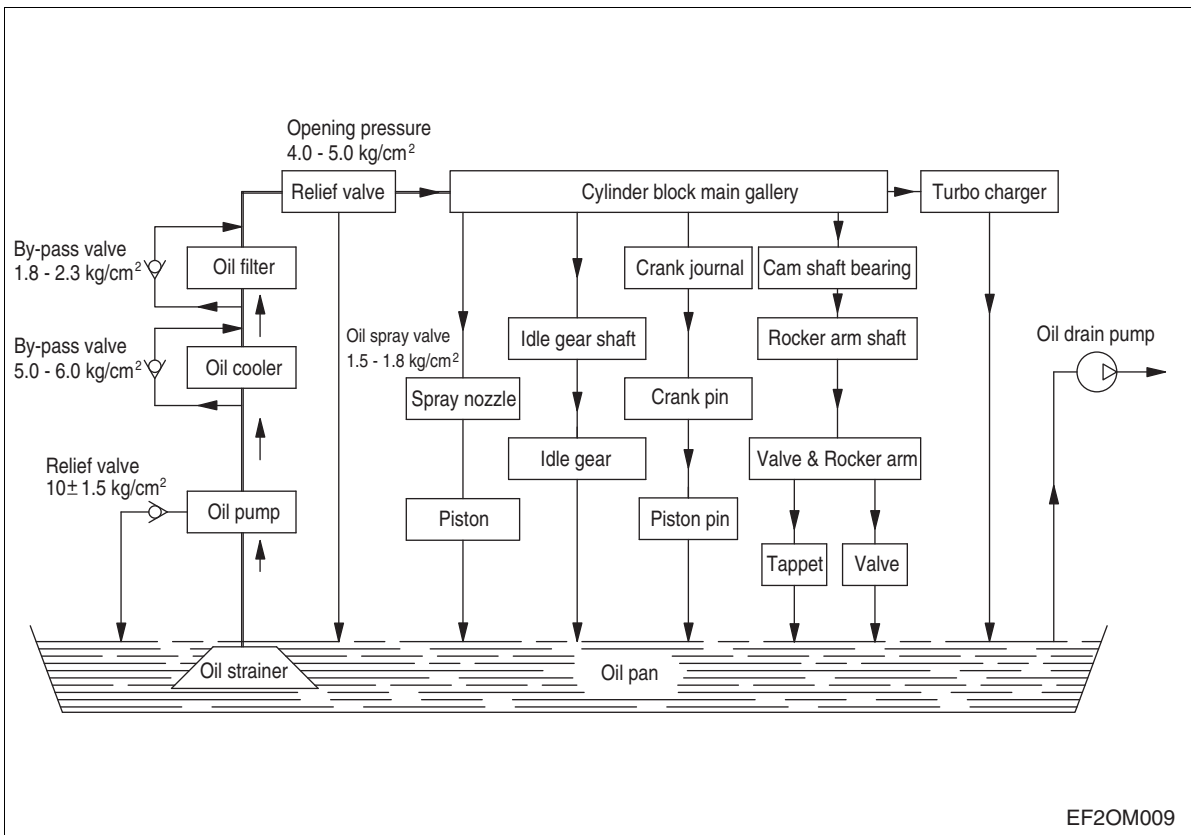

### 2.2.11. Engine oil



- Check oil level with the oil level gauge and replenish if necessary.
- Check the oil level with the engine cooled. If the engine is warm, allow time for 5 ~ 10 minutes for oil drain into the crankcase before checking oil level. The oil level must be between **Max.** and **Min.** lines on the gauge.
- Engine oil should be changed at the specified intervals.  
Oil in the oil filter cartridge should be changed simultaneously.
- The oil viscosity grades should be selected SAE NO.15W40 and API CD or CE.

First oil change		After 50hr operation
Engine model	GE08TIC	every 200hr

- The following oils are also recommended

SAE No.	API No.	Sulfated ash content
15W40	above CD or CE	Bellow 0.5%

Recommend oil : TOTAL LMG-405

Mobil Delvac super GEO 15W40

- Engine oil capacity

Engine model	Engine oil capacity		Total (lit)
	in Oil pan		
	Max. (lit)	Min. (lit)	
GE08TIC	23	17	25

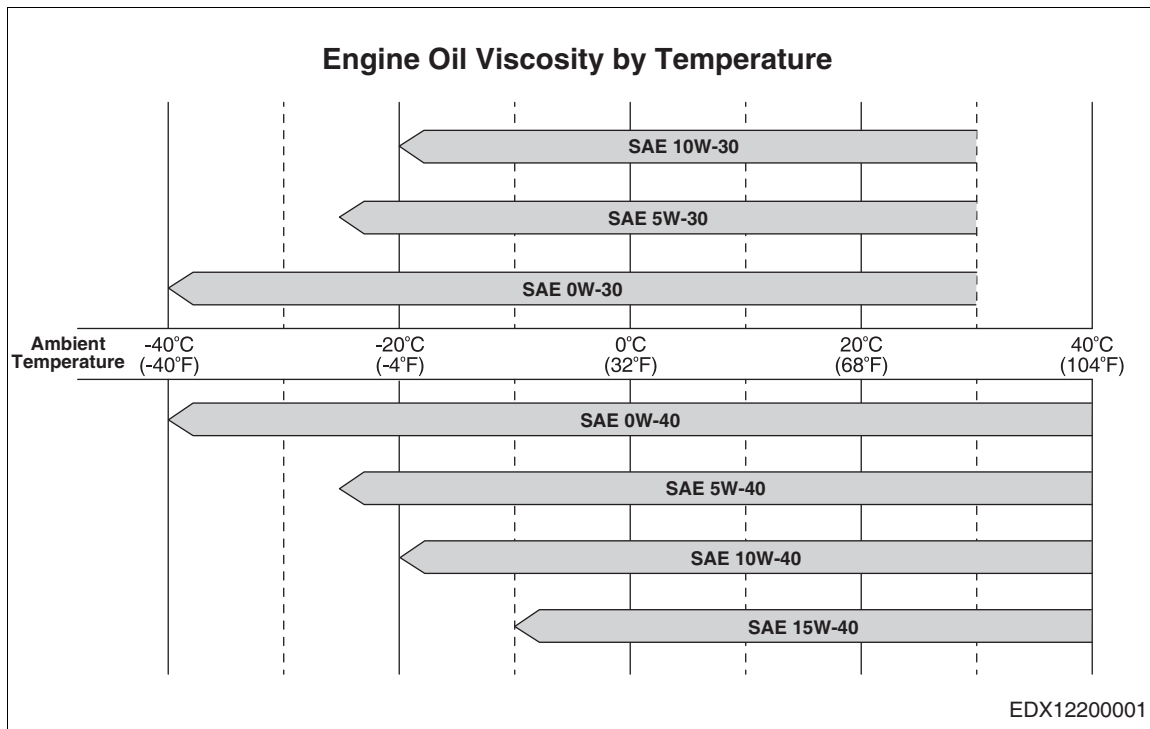

### 2.2.12. Exchanging of lubrication oil

- Engine oil and the oil filter are important factors affecting engine life. They affect ease of starting, fuel economy, combustion chamber deposits and engine wear.
- While the oil is still hot, discharge the sump oil by motion oil drain pump lever manually as figure.

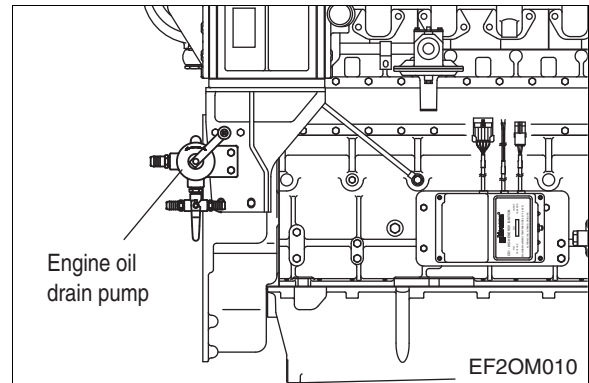

- Refill new engine oil to the filler neck on the head cover in accordance with the oil capacity of the engine. Be careful about the mixing of dust or contaminator during the supplement of oil. Then confirm whether the oil level gauge indicates the vicinity of its maximum level.
- For a few minutes, operate the engine at idling in order to circulate oil through lubrication system. Thereafter shut down the engine. After waiting for about 10 minutes measure the quantity of oil and refill the additional oil if necessary.

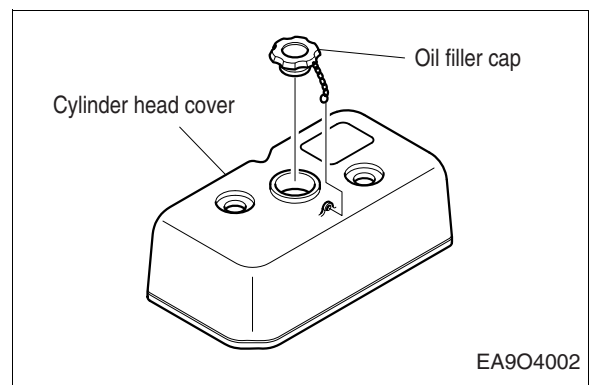

### 2.2.13. Oil cooler & oil filter

- An oil cooler is provided between the oil filter and the cylinder block.
- This cooler is a flat tube type with turbulence inserts and operated by the coolant.
- Check for oil pressure and oil leaks, and repair or replace the oil filter if necessary.
- Change the oil filter cartridge simultaneously at every replacement of engine oil.

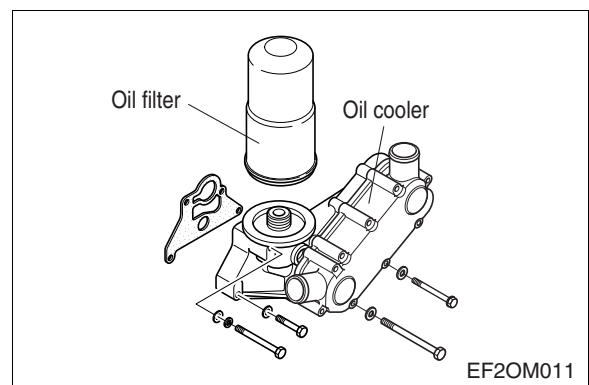

### 2.2.14. Cooling system

- The engine has a liquid-cooling system. The fresh water pump is a maintenance-free by belt from the crankshaft pulley.
- Depending on the agreed extent of delivery and the design of the engine, the coolant circuit can be equipped with temperature monitors which, in the event of loss of coolant, shut the engine down.

#### GEN Pack

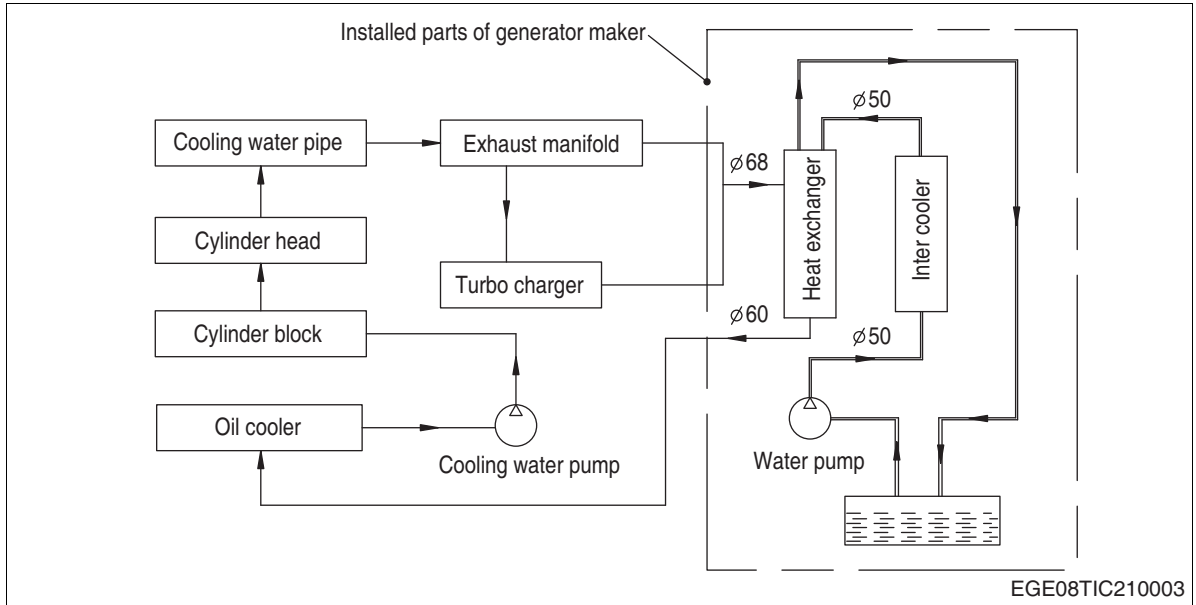

#### Half Engine

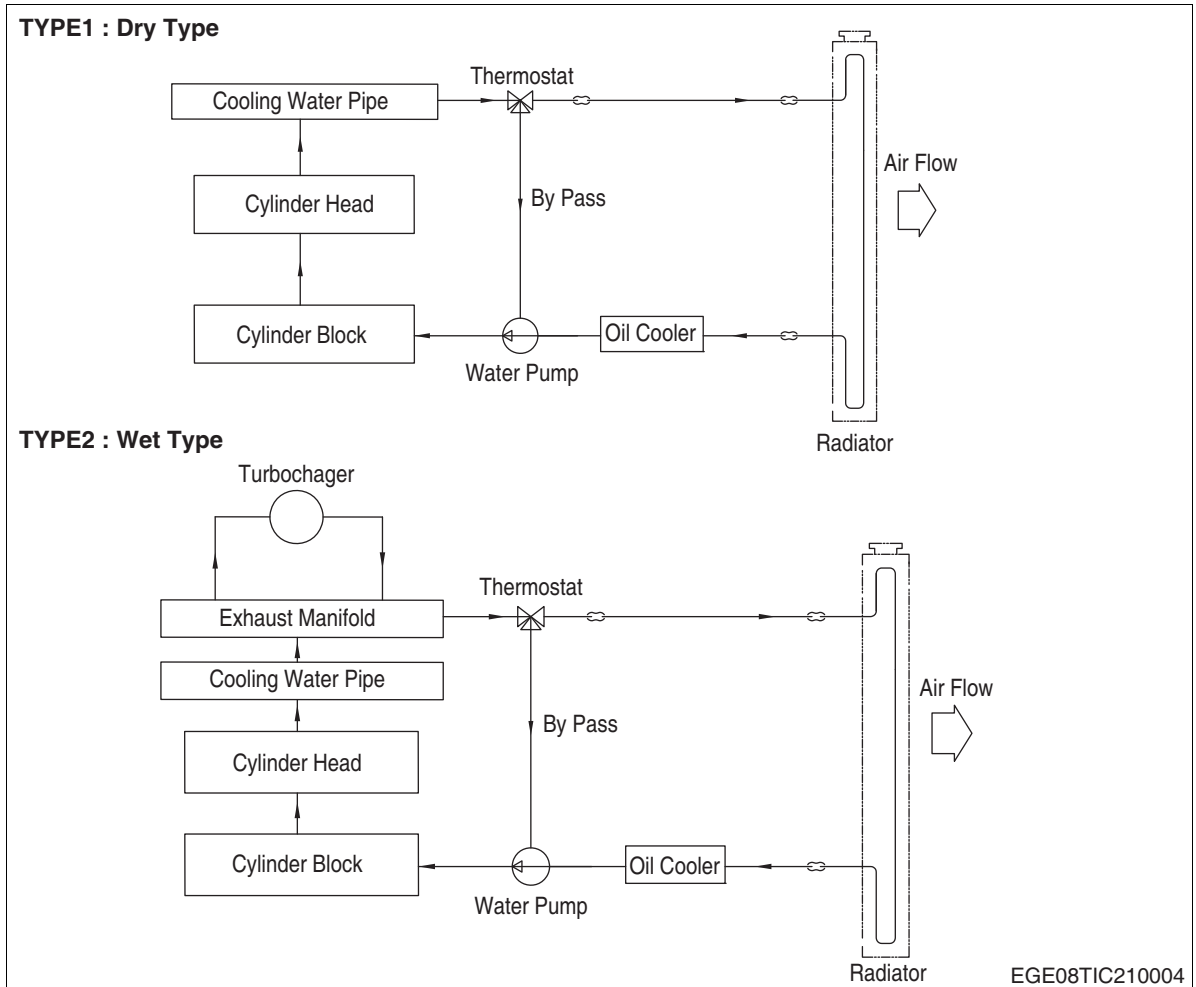

### 2.2.15. Cooling water

- Regarding the cooling water that is to be used for engine, the soft water not the hard water must be used.
- The engine cooling water can be used diluting it with antifreezing solution 40% and the additive for rust prevention (DCA4) 3 ~ 5%.
- The density of above solution and additive must be inspected every 500 hours to maintain it properly.



**NOTE:**

**The proper density control of antifreezing solution and rust preventing additive will be able to prevent the rusting effectively and maintain the stable quality of engine. For the improper control might give the fatal damage to the cooling water pump and cylinder liners, detail care is needed.**

- Since **GE08TIC** cylinder liner is dry type, particularly the cooling water control should be applied thoroughly.
- The density of antifreezing solution and additive for rust prevention is able to be confirmed by the cooling water test kit.  
(Fleetguard CC2602M or HD Hyundai Infracore 65.99901-0038)
- How to use the cooling water test kit
  - (1) When the cooling water temp. of engine is in the range of 10 ~ 55°C, loosen the plug for cooling water discharge and fill the plastic cup about a half.



**NOTE:**

**In taking the cooling water sample, if the water in auxiliary tank were taken, it is hard to measure the accurate density. Take the cooling water sample necessarily loosening the cooling water discharge plug.**

- (2) At the state of a test paper soaked in the sampled water, after taking the paper out through water agitation, shake off the water.
- (3) Wait for about 45 sec. till the color change of test paper.



**NOTE:**

**However, it should not elapse longer than 75 sec, and if it did, the hue would change.**

- (4) Make the numerical value by comparing the test paper which hue has changed with the color list of label on storage bottle.
- (5) By comparing the hue changed into yellowish green or so with the green color indication of test paper storage bottle, confirm the density. (Then, the density indication must be in the hue range of 33% to 50%).
- (6) The brown at the middle of test paper and the lower pink color indication represent the additive state for rust prevention, and the proper range is that the meeting numerical value of brown (vertical) and pink color (horizontal) locates in the range of 0.3 to 0.8 at the color list of label on the test paper storage bottle.
- (7) In case of less than 0.3, replenish the additive for rust prevention (DCA4), and in case of more than 0.8, pour out the cooling water about 50% and then readjust the density after refilling with clean fresh water.

- Amount of Anti-freeze in winter

Ambient Temperature (°C)	Cooling water (%)	Anti-freeze (%)
Over -10	85	15
-10	80	20
-15	73	27
-20	67	33
-25	60	40
-30	56	44
-40	50	50

### 2.2.16. V - belt



- Use a fan belt of specified dimensions, and replace if damaged, frayed, or deteriorated.
- Check the fan belt for belt tension.
- If belt tension is lower than the specified limit, adjust the tension by relocating the alternator. (specified deflection: 10 ~ 15 mm when pressed down with thumb)

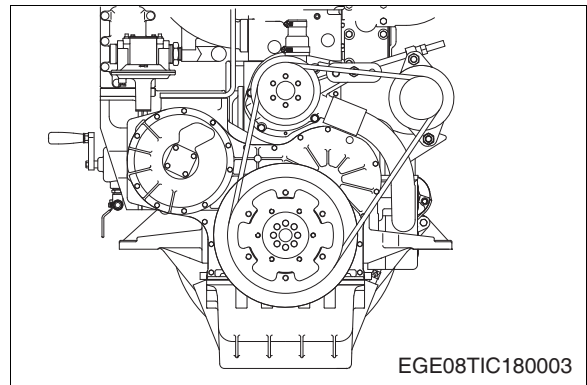

### 2.2.17. Air cleaner

- In case that elements are deformed, damaged or if the air cleaner has a crack, replace it.
- By the definite interval, the elements must be cleaned and replaced.

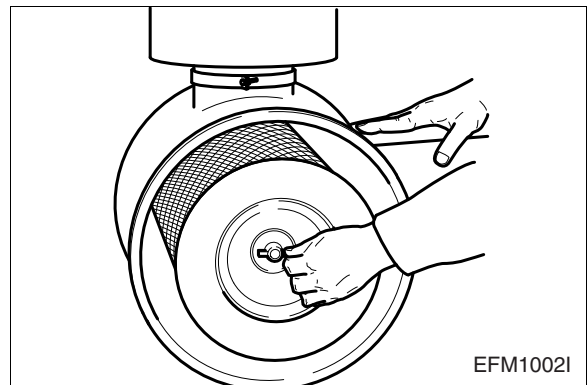

### 2.2.18. Intercooler

- The intercooler is air-gas to water type. The intercooler life and performance depends on the intake air condition greatly.
- So you always check whether the intake air systems like air filter element are worn or polluted.

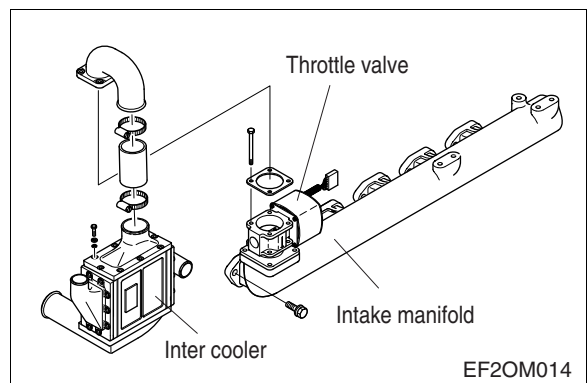

### 2.2.19. Valve clearance adjust procedure



● After letting the #1 cylinder's piston come at the compression top dead center by turning the crankshaft, adjust the valve clearances.



● Loosen the lock nuts of rocker arm adjusting screws and push the feeler gauge of specified value between a rocker arm and a valve stem and adjust the clearance with adjusting screw respectively and then tighten with the lock nut.

● As for the valve clearance, adjust it when in cold, as follow.

Specified Value		Measurement Tolerance	
Intake Valve	Exhaust Valve	Intake Valve	Exhaust Valve
0.4 mm	0.4 mm	±0.05 mm	

#### ● Adjusting Sequence of Valve Clearance (1 Type)

- By cranking the engine, let #6 cylinder's valves overlap.
- In time, adjust the valve clearance corresponding to " ⇐ " of lower lists.
- Adjust the valve clearance corresponding to " → " of lower lists.
- After reinsuring the valve clearances, retighten if necessary.

● No. 1 Cylinder is located at the side where flywheel was installed.

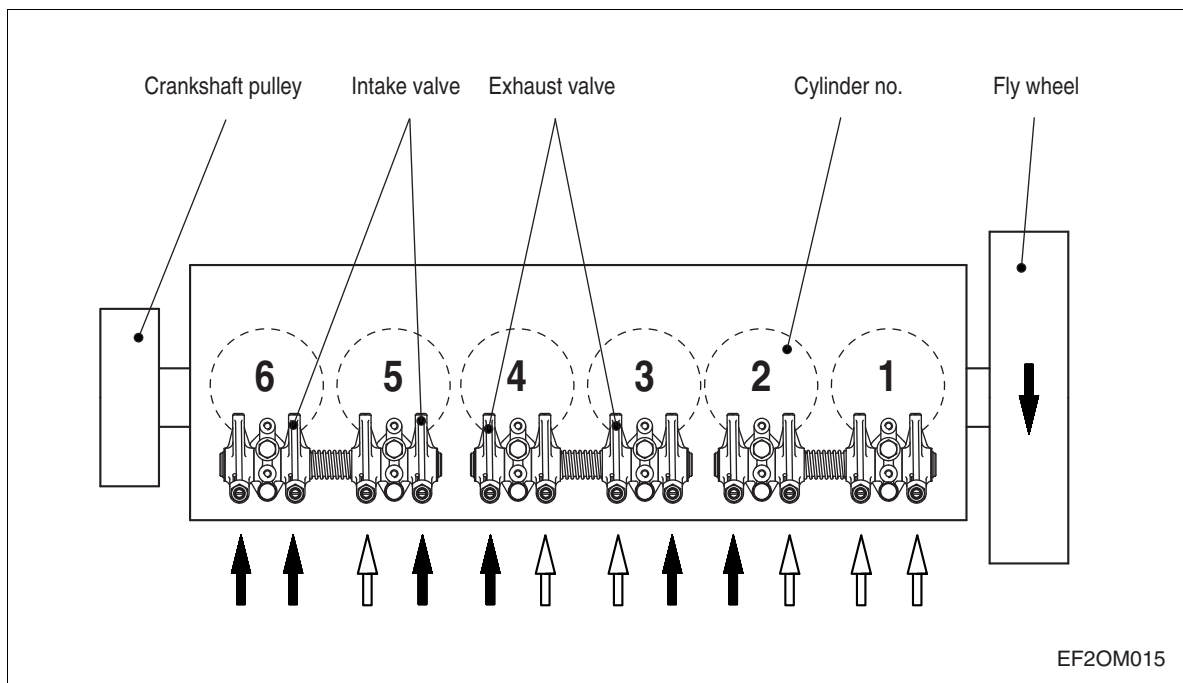

#### ● Adjusting Sequence of Valve Clearance (2 Type)

1 Type is the conventional and simple method, but if you have some problem to adjust your engine, please try 2 type sequence. This is a precision method, but it takes more times.

Valve overlapping on cylinder (Intake & Exhaust valve)	1	5	3	6	2	4
Adjusting valves on cylinder (Intake & Exhaust valve)	6	2	4	1	5	3

### 2.2.20. Spark plug



- Remove spark plug. Clean threads by hand with brush and solvent.
- Clean any deposits from electrode and inspect insulator area
- Measure the spark plug distance at electrode position.(A)
- Replace spark plug if necessary.

	Standard
Distance (A)	0.39 ~ 0.40 mm



- Install spark plug

Torque	2.04 ~ 4.08 kg.m
--------	------------------

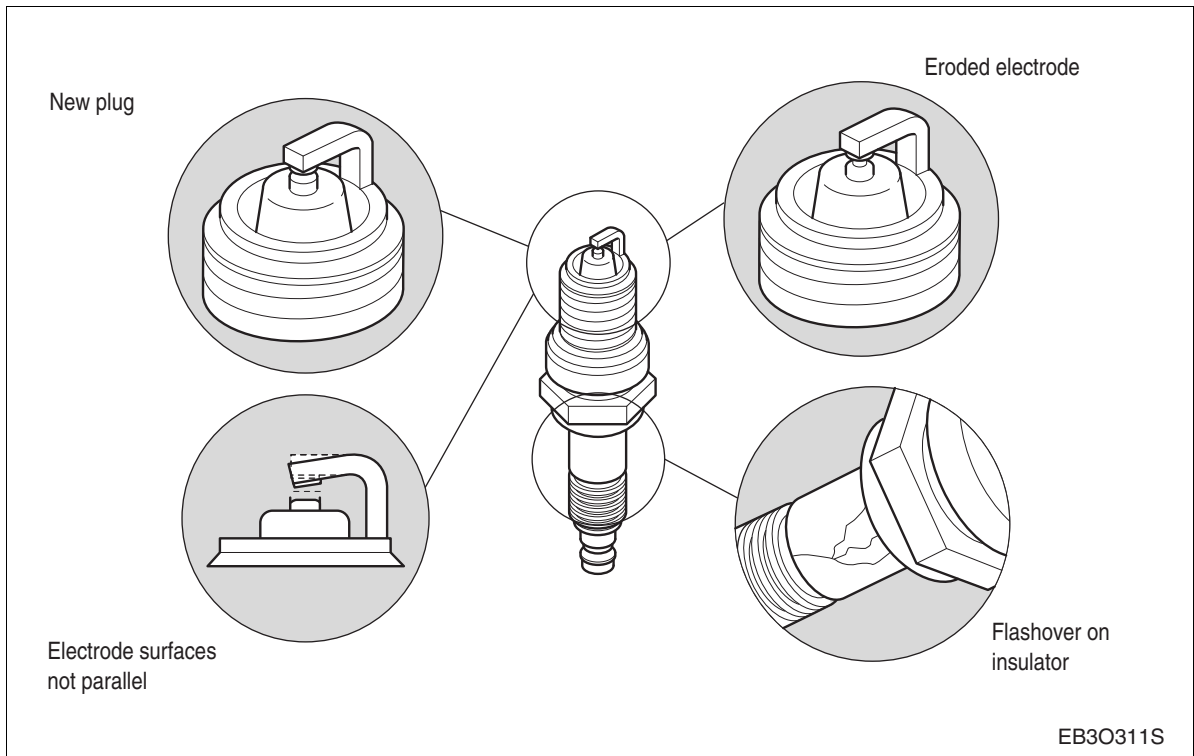
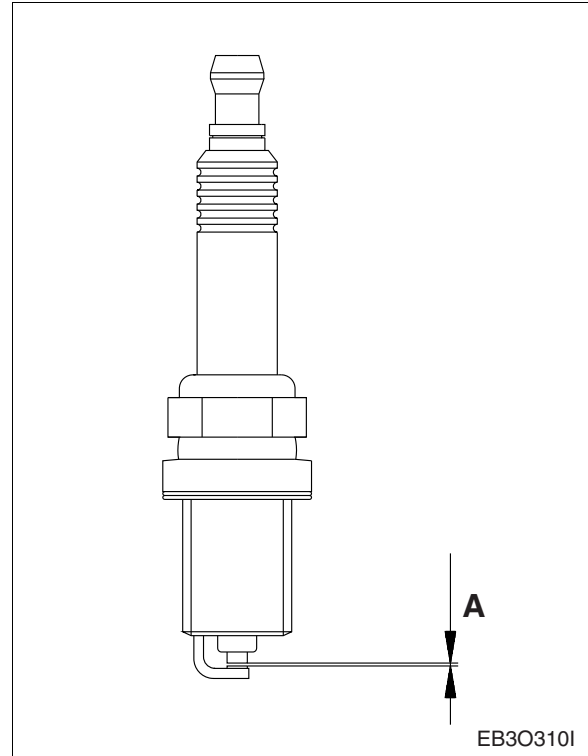

### 2.2.21. Cylinder compression pressure



- Stop the engine after warming up, and take out spark plug.

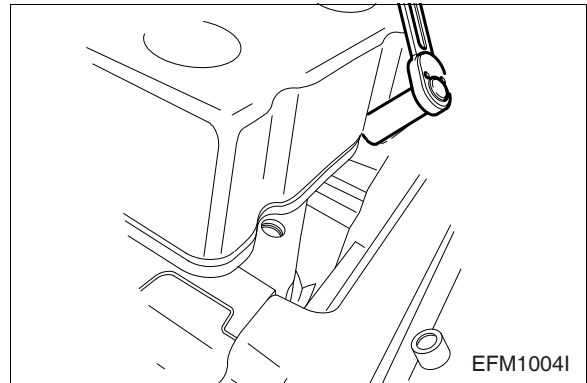

- Install the special tool (compression gauge adapter) at the spark plug hole and connect the compression pressure gauge there.

Standard value	16 kg/cm <sup>2</sup> over
Limit value	13 kg/cm <sup>2</sup>
Difference between each cylinder	Within $\pm 10\%$

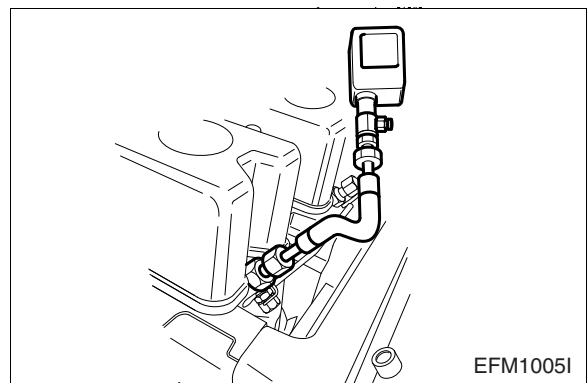

- ◆ Condition : Water temperature 20°C,  
Engine rotation 200rpm

### 2.2.22. Battery



- Inspect for any leakage of electrolytic solution owing to battery crack, and replace the battery in case of poor condition.
- Inspect for amount of electrolytic solution, and replenish if insufficient.
- Measure the gravity of electrolytic solution, if less than specified value (1.12 ~ 1.28), replenish.

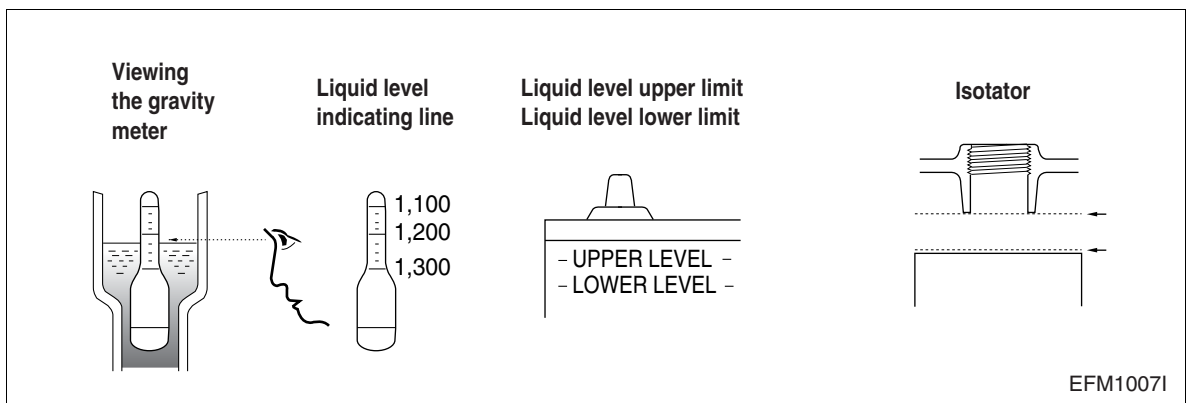



## 2.2.24. Alternator

### ● Alternator (24Vx45A)

The alternator is fitted with integral silicon rectifiers. A transistorized regulator mounted on the alternator body interior limits the alternator voltage. The alternator should not be operated except with the regulator and battery connected in circuit to avoid damage to the rectifier and regulator.

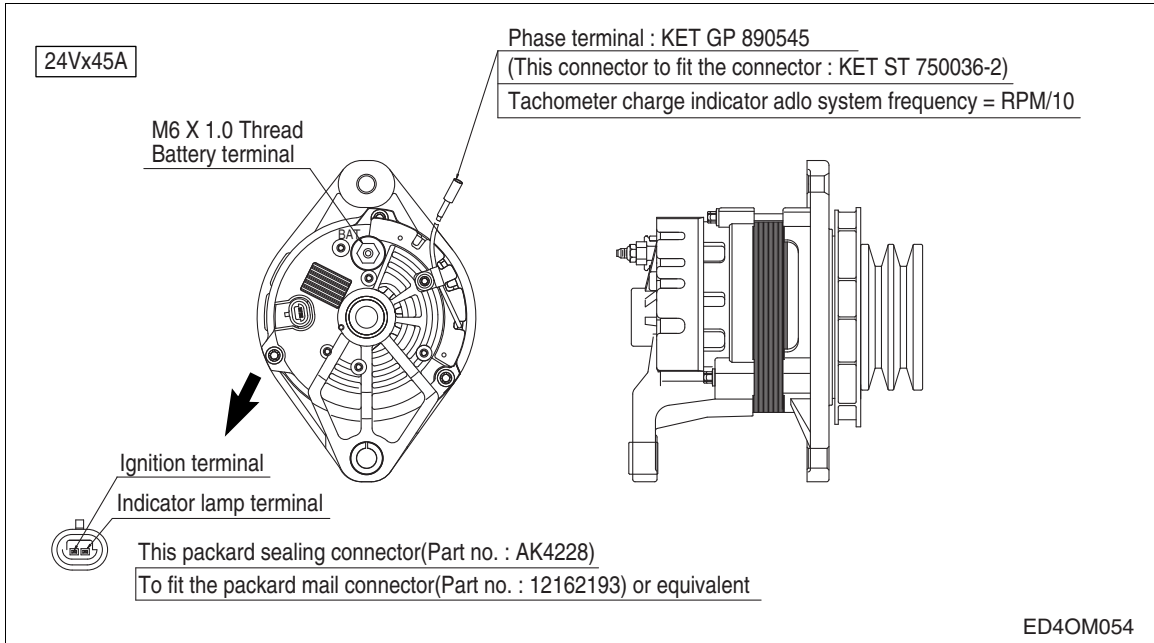

The alternator is maintenance-free, nevertheless, it must be protected against dust and, above all, against moisture and water.

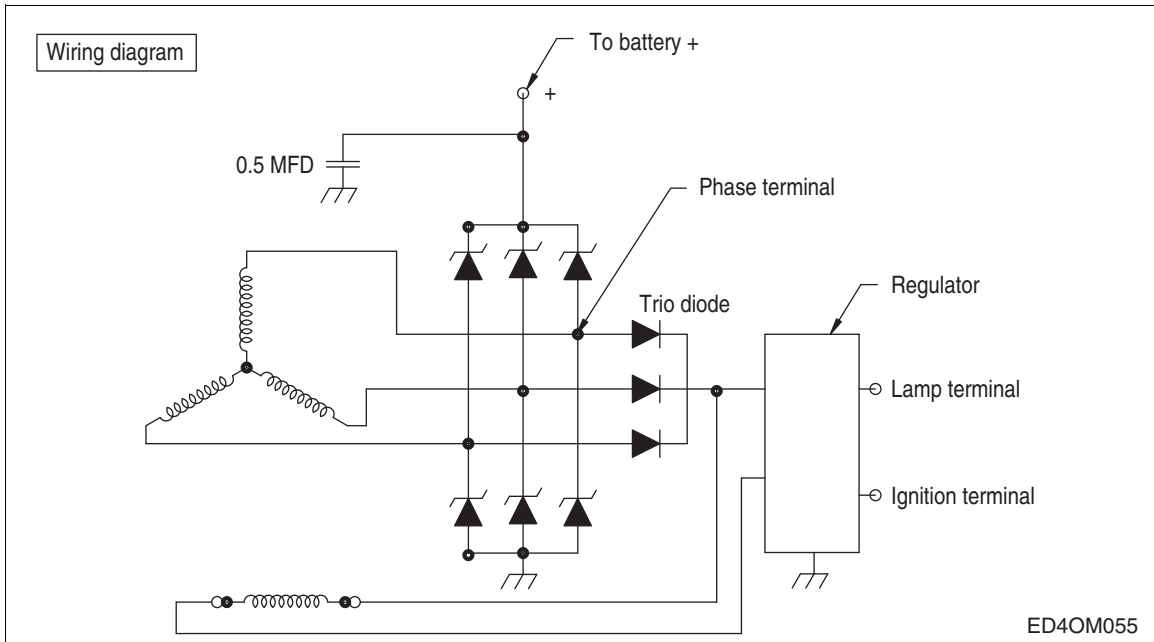

Operate the alternator according to the instructions given in the chapter.

### 2.2.25. Starting motor

The sliding-gear starter motor is flanged to the rear of the flywheel housing on the left-hand side. As parts of every engine overhaul, the starter pinion and ring gear should be cleaned with a brush dipped in fuel and then a coat of grease should be applied again.

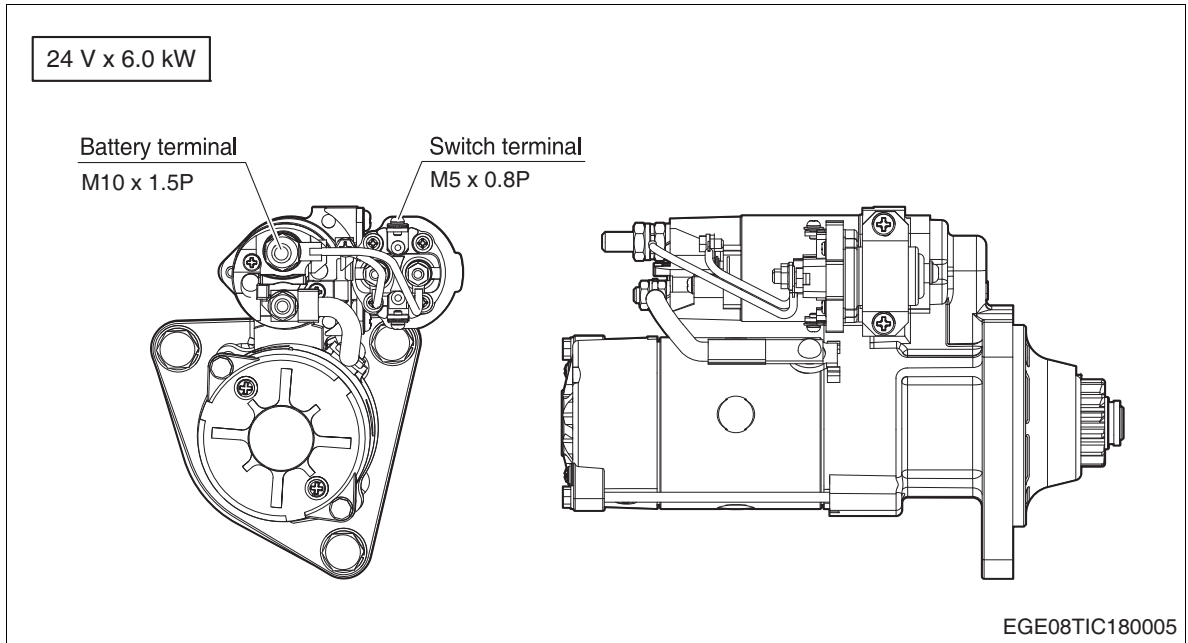

Always protect starter motor against moisture.

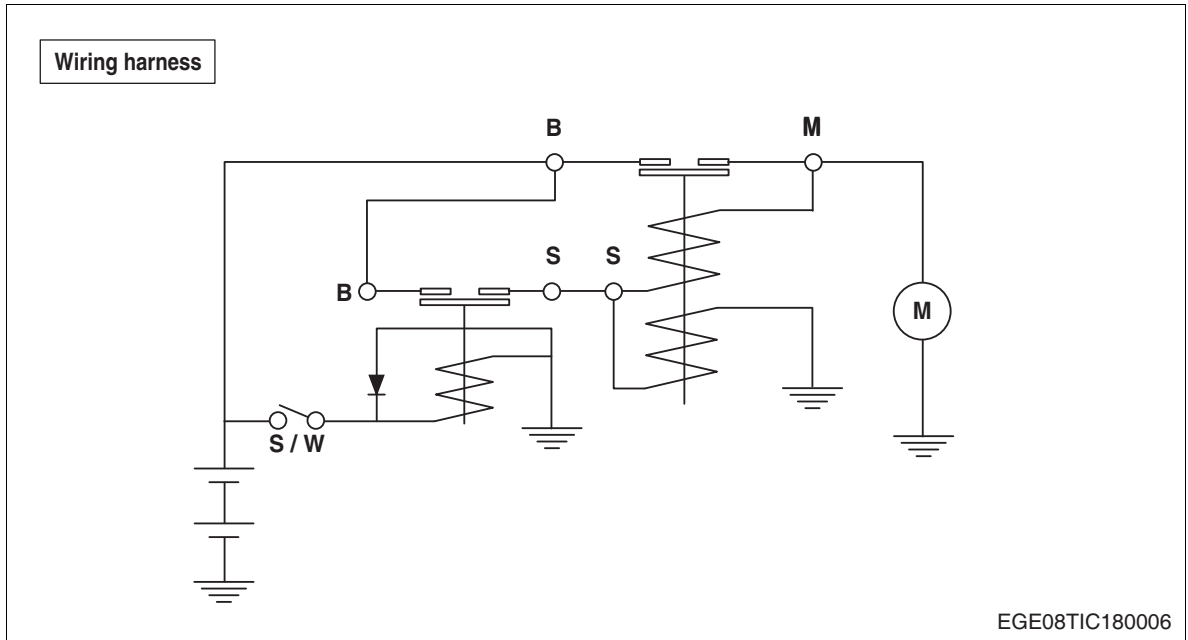

#### WARNING:

Always disconnect the battery earth cable before starting work on the electrical system. Connect up the earth cable last, as there is otherwise a risk of short-circuits.

## 2.3. Diagnosis and remedy

- The following description summarizes the probable cause of and remedy for general failure by item.
- Immediate countermeasures should be taken before a failure is inflamed if any symptom is detected.

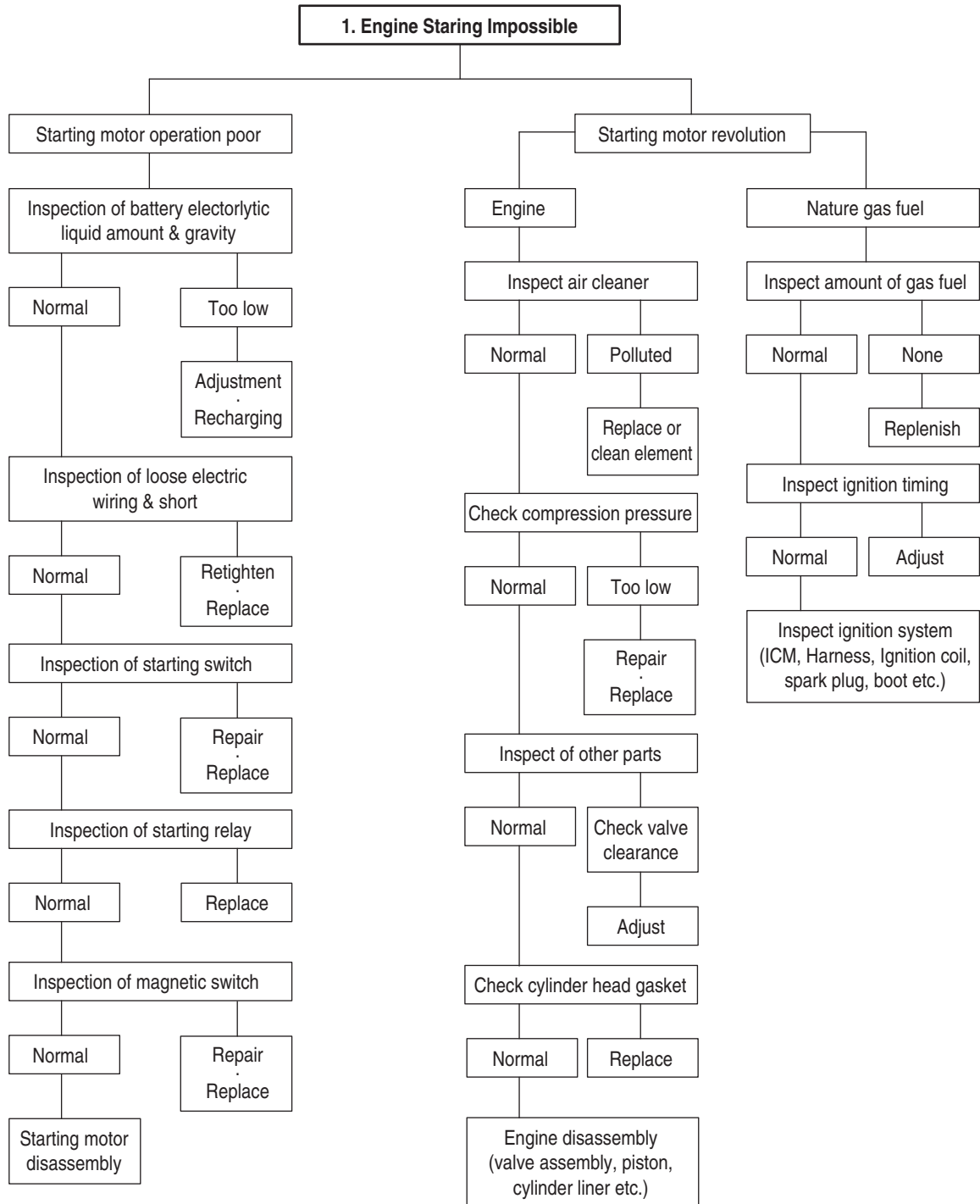

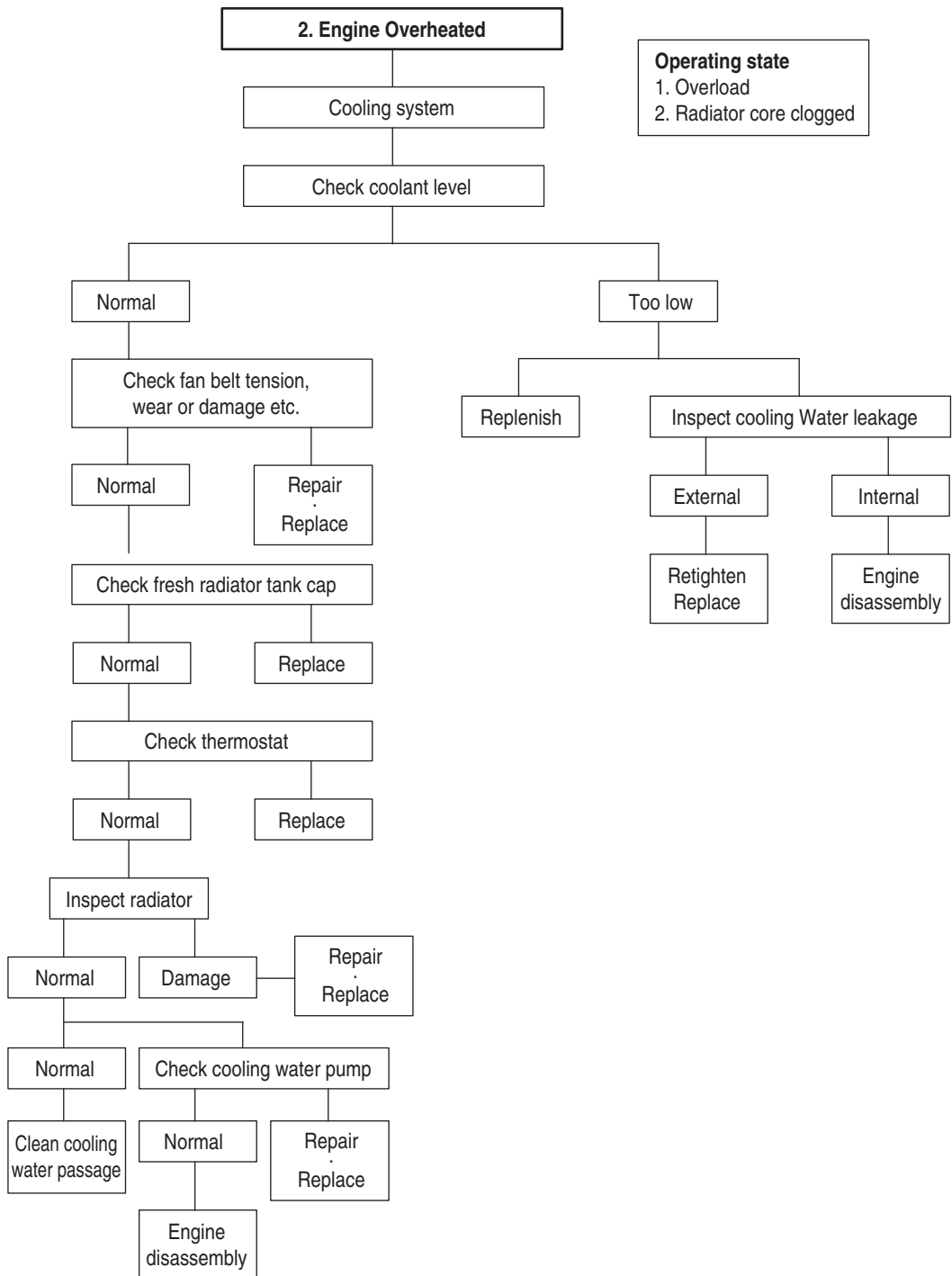

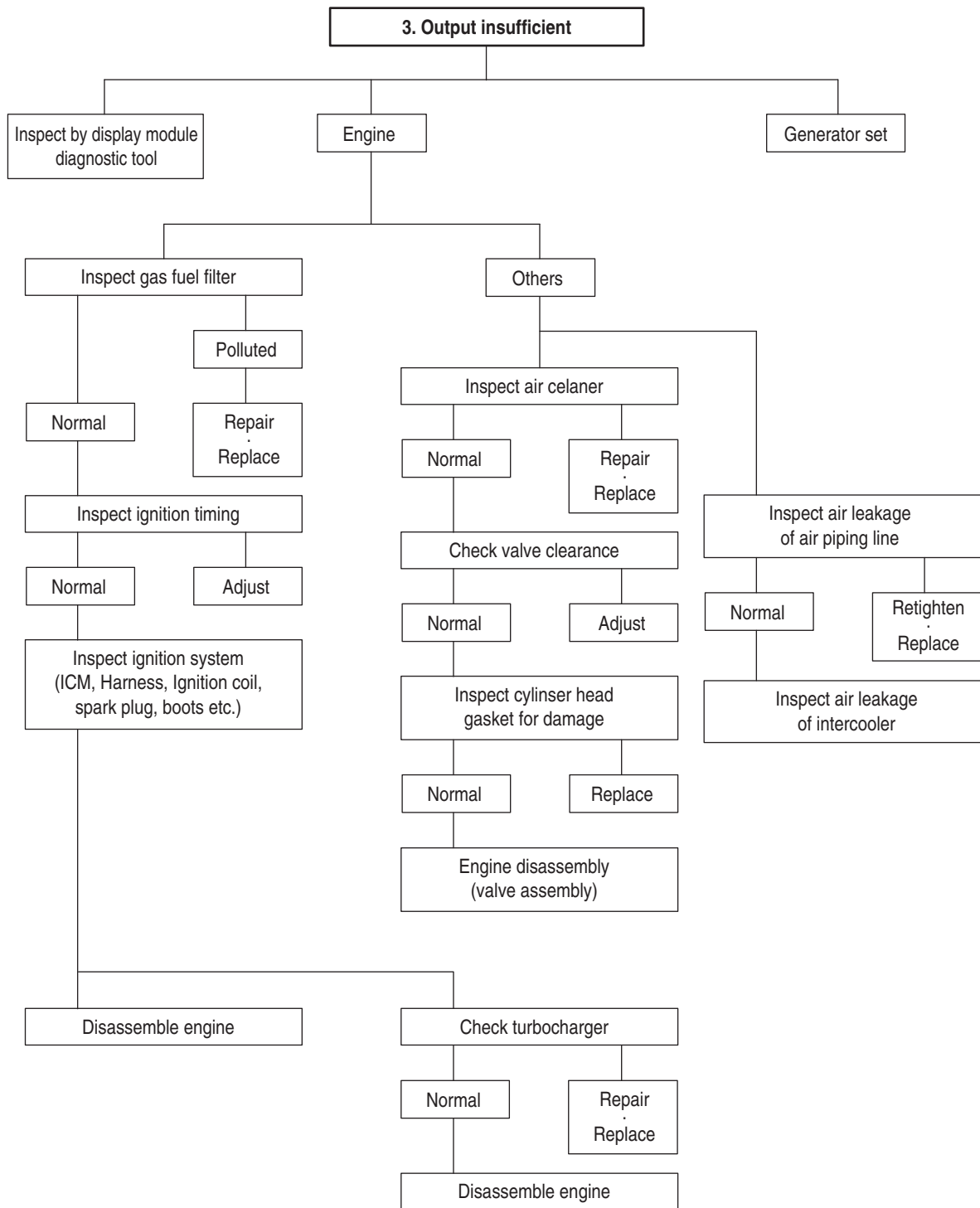

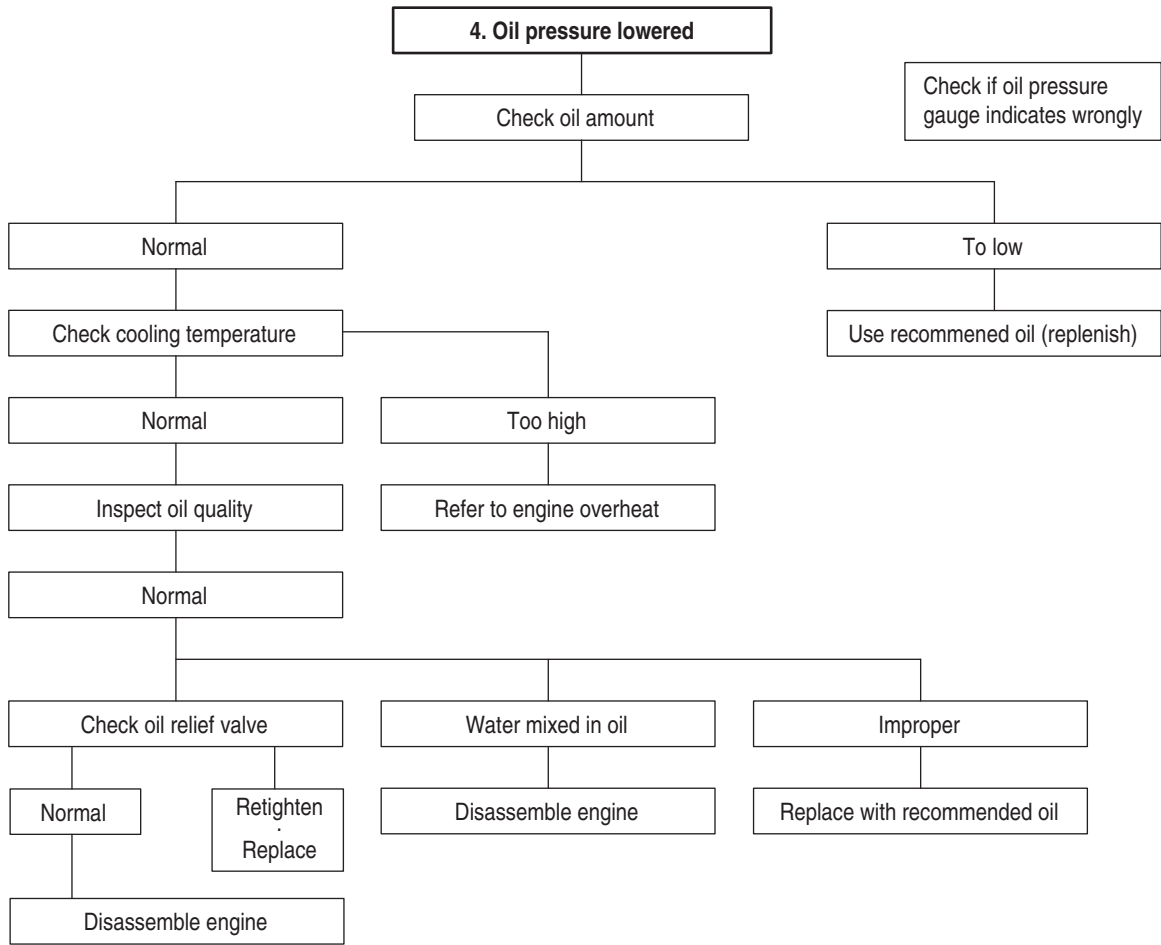

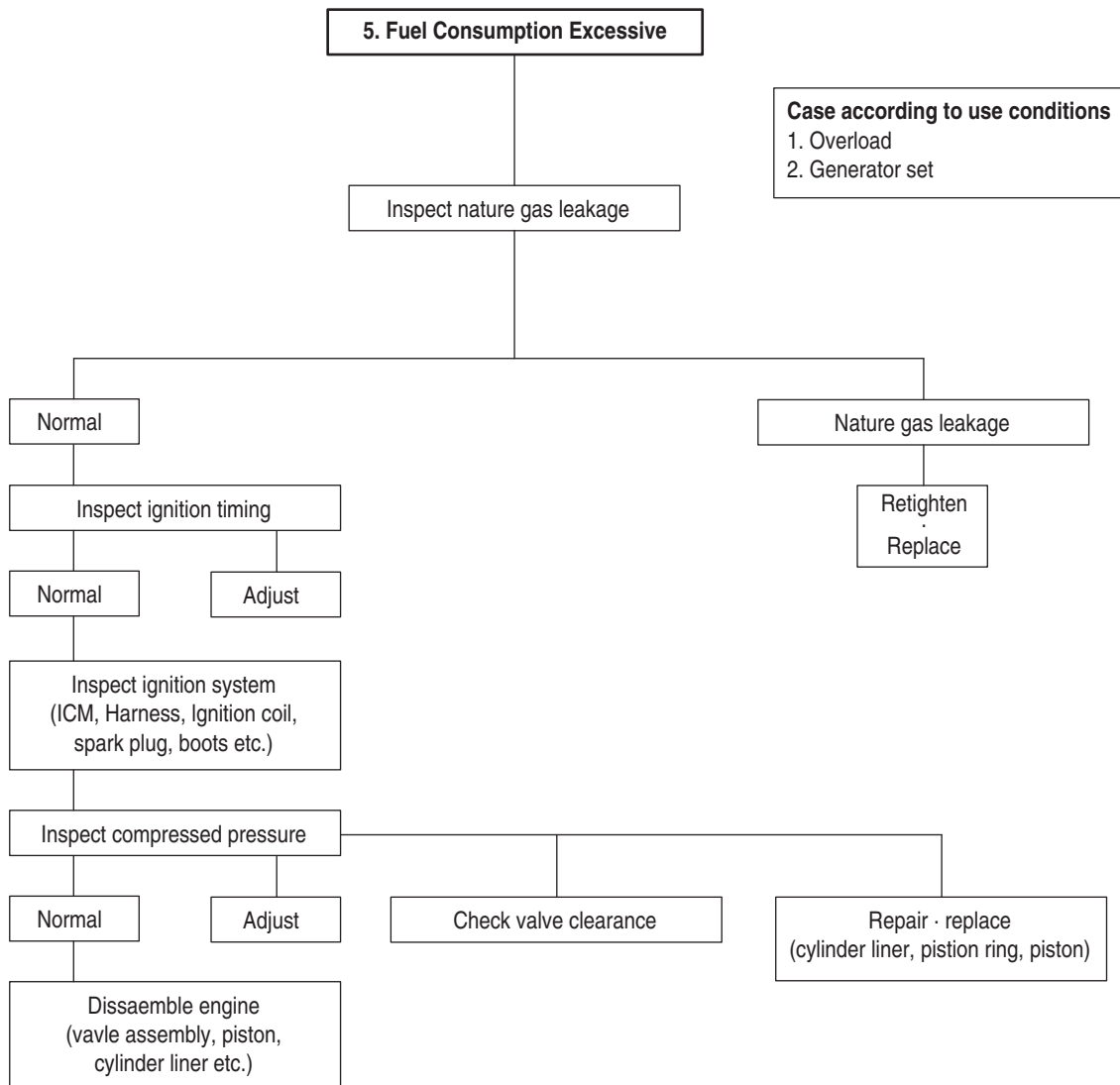

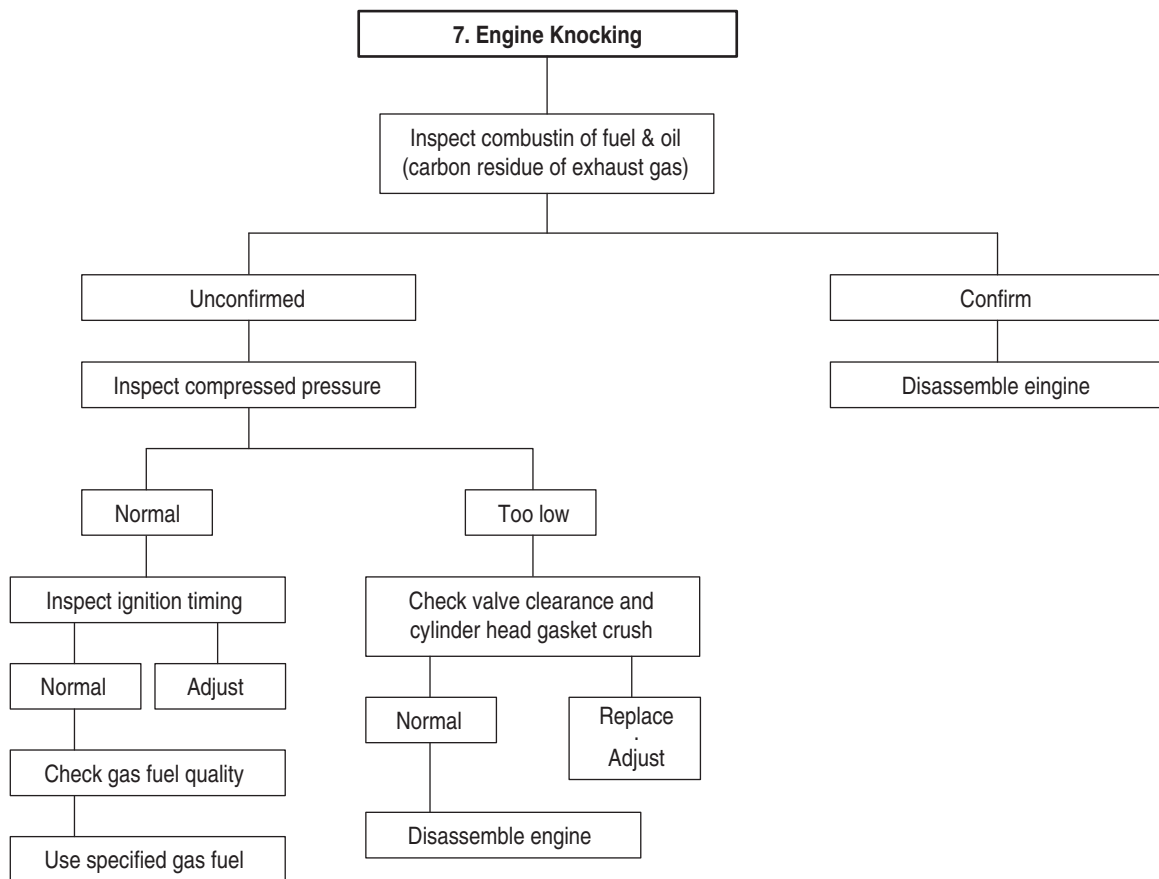
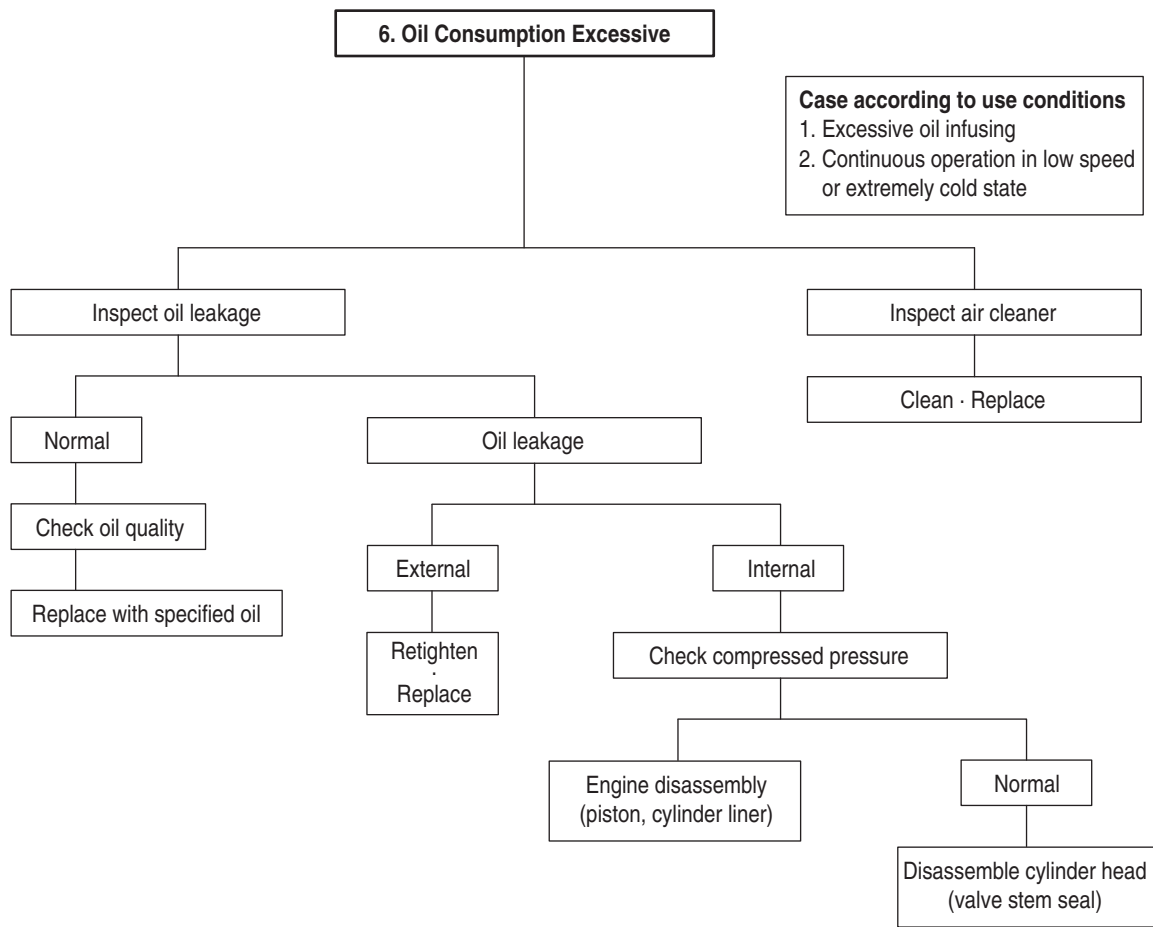

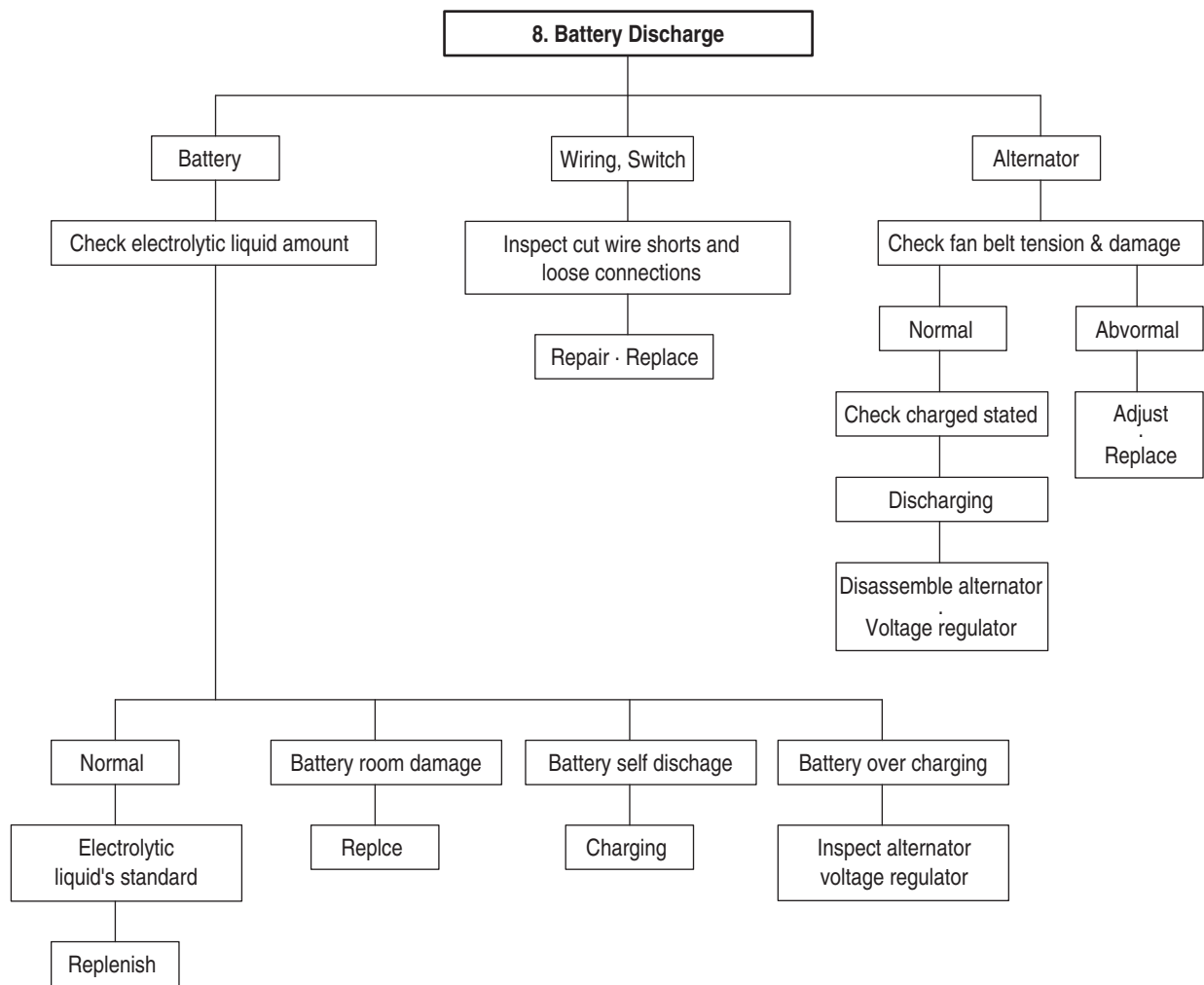

Condition	Causes	Remedies
1) Starting difficult (1) Compression pressure	<ul style="list-style-type: none"> <li>● Valve's poor shut, stem distortion</li> <li>● Valve spring damage</li> <li>● Cylinder head gasket's leak</li> <li>● Wear of piston, piston ring or liner</li> </ul>	<p>Repair or replace</p> <p>Replace valve spring</p> <p>Replace gasket</p> <p>Adjust</p>
2) Idle operation abnormal	<ul style="list-style-type: none"> <li>● Ignition timing incorrect</li> </ul>	Adjust
3) Engine output insufficient (1) Continuous output insufficient	<ul style="list-style-type: none"> <li>● Valve clearance incorrect</li> <li>● Valve tightness poor</li> <li>● Cylinder head gasket's leak</li> <li>● Wear, stick, damage of piston ring</li> <li>● Ignition timing incorrect</li> <li>● Damage of spark plug &amp; ignition coil</li> <li>● Air suction amount insufficient</li> <li>● Turbocharger poor</li> </ul>	<p>Adjust</p> <p>Repair</p> <p>Replace gasket</p> <p>Replace piston ring</p> <p>Adjust</p> <p>Adjust or replace</p> <p>Clean or replace air cleaner</p> <p>Repair or replace</p>
(2) Output insufficient when in acceleration	<ul style="list-style-type: none"> <li>● Compression pressure insufficient</li> <li>● Ignition timing incorrect</li> <li>● Damage of spark plug &amp; ignition coil</li> <li>● Air intake amount insufficient</li> </ul>	<p>Disassemble engine</p> <p>Adjust</p> <p>Repair or replace</p> <p>Clean or replace air cleaner</p>
4) Overheating	<ul style="list-style-type: none"> <li>● Engine oil insufficient or poor</li> <li>● Cooling water insufficient</li> <li>● Fan belt loosened, worn, damaged</li> <li>● Cooling water pump's function lowered</li> <li>● Water temperature regulator's operation poor</li> <li>● Valve clearance incorrect</li> <li>● Exhaust system's resistance increased</li> </ul>	<p>Replenish or replace</p> <p>Replenish or replace</p> <p>Adjust or replace</p> <p>Repair or replace</p> <p>Replace</p> <p>Adjust</p> <p>Clean or replace</p>

Condition	Causes	Remedies
5) Engine noisy	For noises arise compositely such as rotating parts, lapping parts etc., there is necessity to search the cause of noises accurately.	
(1) Crankshaft	<ul style="list-style-type: none"> <li>● As the wear of bearing or crankshaft progress, the oil clearances increase.</li> <li>● Lopsided wear of crankshaft</li> <li>● Oil supply insufficient due to oil passage clogging</li> <li>● Stuck bearing</li> </ul>	<p>Replace bearing &amp; grind crankshaft</p> <p>Grind or replace Clean oil passage</p> <p>Replace bearing &amp; Grind</p>
(2) Connecting rod and Connecting rod bearing	<ul style="list-style-type: none"> <li>● Lopsided wear of con rod bearing</li> <li>● Lopsided wear of crank pin</li> <li>● Connecting rod distortion</li> <li>● Stuck bearing</li> <li>● Oil supply insufficiency as clogging at oil passage progresses</li> </ul>	<p>Replace bearing</p> <p>Grind crankshaft Repair or replace Replace &amp; grind crankshaft Clean oil passage</p>
(3) Piston, piston pin & piston ring	<ul style="list-style-type: none"> <li>● Piston clearance increase as the wear of piston and piston ring progresses</li> <li>● Wear of piston or piston pin</li> <li>● Piston stuck</li> <li>● Piston insertion poor</li> <li>● Piston ring damaged</li> </ul>	<p>Replace piston &amp; piston ring</p> <p>Replace Replace piston Replace piston Replace piston</p>
(4) Others	<ul style="list-style-type: none"> <li>● Wear of crankshaft, thrust bearing</li> <li>● Camshaft end play increased</li> <li>● Idle gear end play increased</li> <li>● Timing gear backlash excessive</li> <li>● Valve clearance excessive</li> <li>● Abnormal wear of tappet, cam</li> <li>● Turbocharger inner part damaged</li> </ul>	<p>Replace thrust bearing</p> <p>Replace thrust plate</p> <p>Replace thrust washer Repair or replace</p> <p>Adjust valve clearance Replace tappet, cam</p> <p>Repair or replace</p>



## 2.4. Engine inspection

### 2.4.1. Stopping engine

- Cut off the main circuit breaker of the generator control panel. After checking the engine for any unusual condition at the idling speed, then press the stop button to stop the engine.

### 2.4.2. General engine inspection cycle

- In order to insure maximum, trouble-free engine performance at all times, regular inspection, adjustment and maintenance are vital.
  - Daily inspections in below figure should be checked every day.
  - The following maintenance details should be executed thoroughly at regular intervals.

○ : Check & adjust ● : Replace

Inspection Item		Daily	Every 50hrs	Every 200hrs	Every 500hrs	Every 1500hrs	Every 3000hrs	Remark
<b>Cooling System</b>	Check for leakage(hoses, clamp)	○						
	Check the water level	○						
	Adjust the V-belt tension	○						
	Change the coolant water							● 1 year
<b>Lubrication System</b>	Check for leakage	○						
	Check the oil level gauge	○						
	Change the lubricating oil		● 1st	●				Every 200hr
	Replace the oil filter cartridge		● 1st	●				Every 200hr
<b>Intake &amp; Exhaust System</b>	Check the leakage for intercooler (hoses, clamp)	○						
	Check the air cleaner indicator	○				●		
	Clean the air cleaner element and/or repair			○ Clean	●			
	Clean the exhaust system						○	
<b>Fuel System</b>	Check the leakage fuel line	○						
	Check the fuel mixer							○ 1 year
	Check the throttle body							○ 1 year
	Check the speed controller							○ 1 year
	Check the gas pressure regulator							○ 1 year
<b>Ignition system</b>	Check the state of ignition timing							When necessary
	Check the spark plug					●	●	
	Check the ignition cable							● 1 year
	Check the ignition coil							○ 1 year
	Check the sensors(ignition or timing)	○						
<b>Engine Adjust</b>	Check the state of exhaust gas	○						
	Check the exhaust gas pressure							When necessary
	Check the battery charging	○						
	Check the compression pressure							When necessary
	Adjust Intake/Exhaust valve clearance				○			When necessary

### **2.4.3. Use of original parts for repair and replacement**

- For engine is being mechanically harmonized with many parts, only when the original parts that the manufacture recommends to use is used, the engine trouble would be preventively maintained and capable to keep up the maximum performances.
- For the analogous parts not the original parts are poor in qualities and gives ill performances, it may rather bring early engine failure

### 3. Disassembly and Reassembly of Major Components

#### 3.1. Engine disassembly

##### 3.1.1. Heed at disassembly



- Before disassembly, the part shelf should be prepared for various tools and repair parts.
- When assembling, clean empty hand should be used and clean environment maintained.
- In case of storing the disassembled parts, each part should not touch each other.
- In case of disassembly, the parts should be laid in order.

##### 3.1.2. Oil level gauge

- Pull out the oil level gauge.

##### 3.1.3. Cooling water

- Remove the drain plug from the cylinder block and drain out the cooling water into a container.

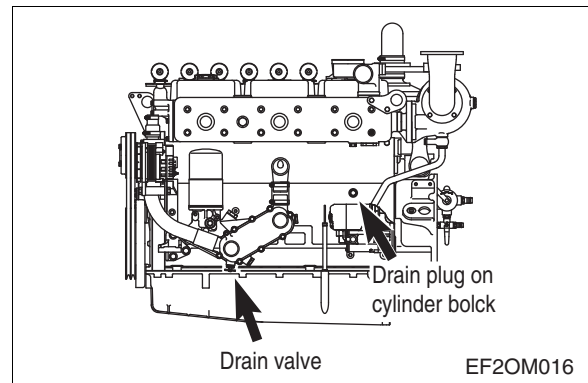

##### 3.1.4. Engine oil

- Turn the valve opening and then move the oil drain pump lever as figure by hand, and let engine oil discharge into the prepared vessel

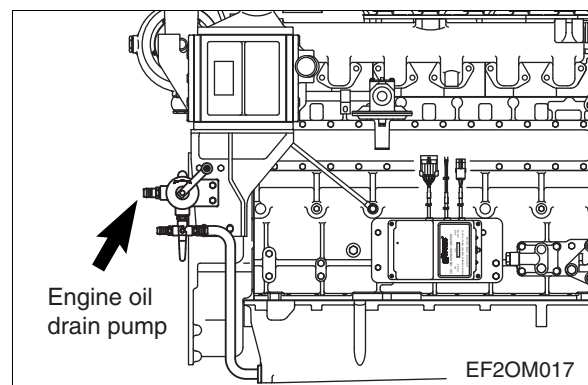

### 3.1.5. Engine speed controller : ESC

- Disconnect the harness and the various sensors.

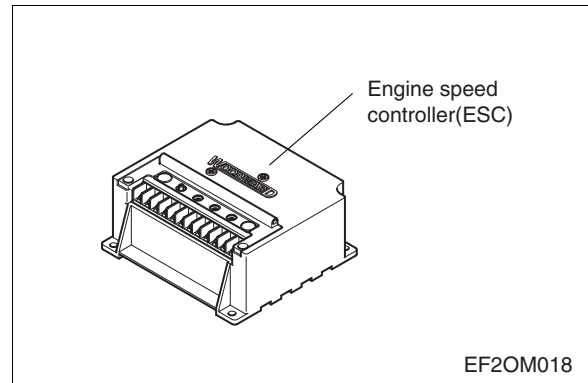

### 3.1.6. Ignition control module (ICM)

- Disconnect the harness and the various sensors.
- Loosen the fixing bolt, then disassemble the ignition control module (ICM).

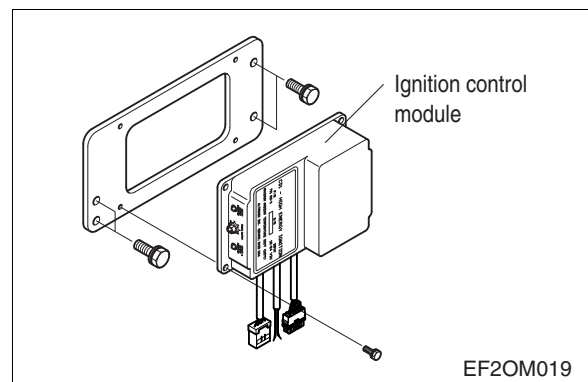

### 3.1.7. Ignition coil & gas pressure regulator

- Remove the high voltage cables by hand from each cylinder head.
- Remove the gas pressure regulator fixing bolts and then tear down the gas pressure regulator and other parts.

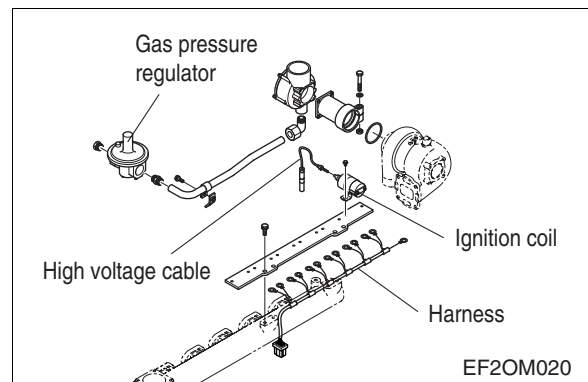

### 3.1.8. Fuel mixer

- Remove the air cleaner from fuel mixer.
- Remove the fuel mixer and air pipe from the turbocharger.

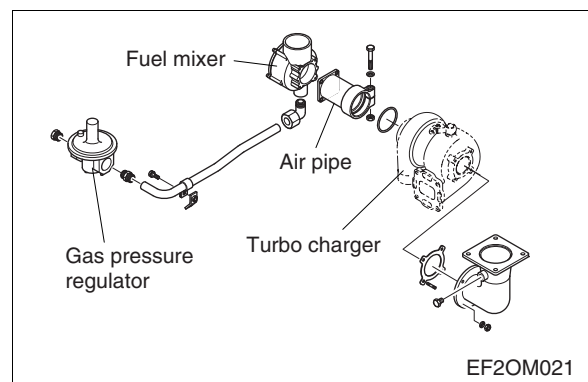

### 3.1.9. Turbocharger

- Remove the oil supply pipe and oil return pipe between the turbocharger and the cylinder block.
- Unclamp the rubber hose connected the intercooler and air pipe.
- Unscrew the turbocharger fixing nuts and take off the turbocharger from the exhaust manifold

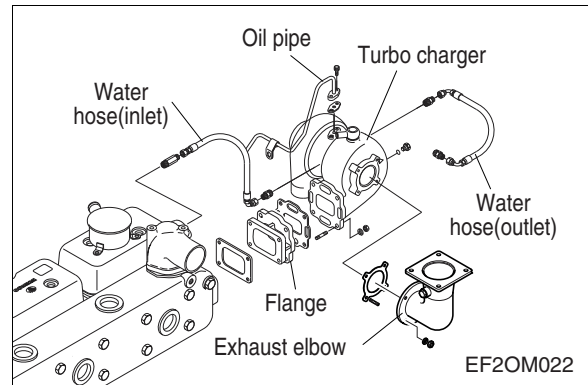

### 3.1.10. Intercooler

- Tear down the various hoses and air pipes from the inter cooler.
- Remove the intercooler fixing bolts and tear it down.

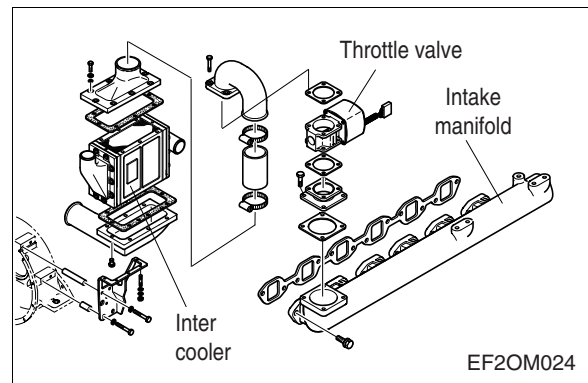
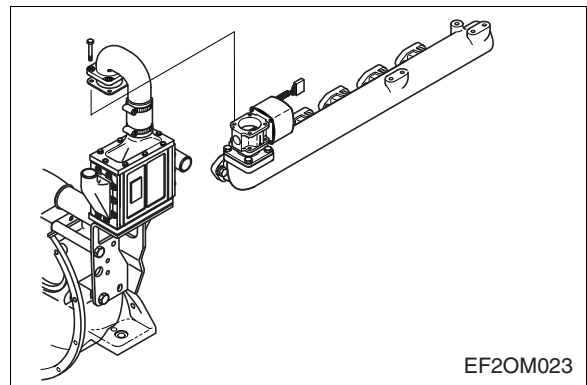

### 3.1.11. Belt

- Loosen the tension adjusting bolts of the alternator and take off the belts.

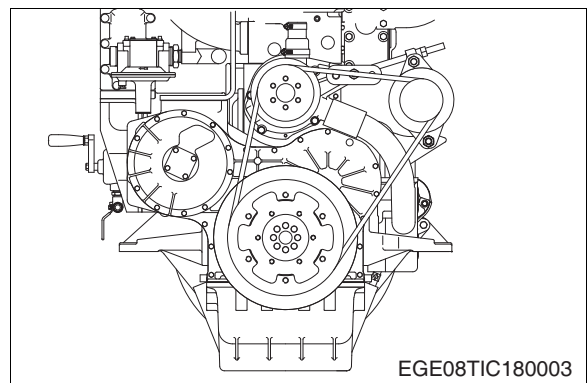

### 3.1.12. Starter

- Unscrew the starter fixing nuts and remove the starter being careful not to damage its gears.

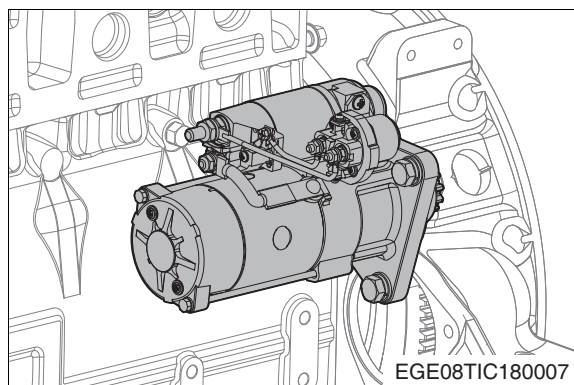

### 3.1.13. Breather

- Unscrew the hose clamp fixing bolts and remove the breather hose.

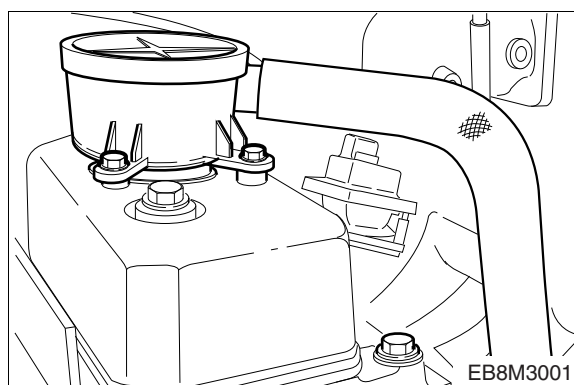

### 3.1.14. Alternator

- Remove the alternator fixing bolts and take off the alternator.

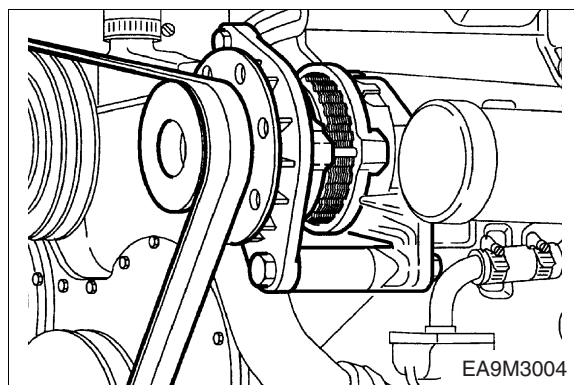

### 3.1.15. Oil cooler & oil filter

- Loosen the cooling water pump and the rubber hose clamps of connected pipes, and disassemble it.
- Remove the oil cooler fixing bolts and take off the oil cooler and oil filter cartridge.

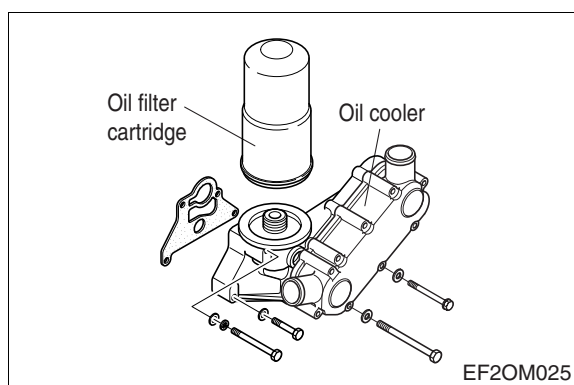

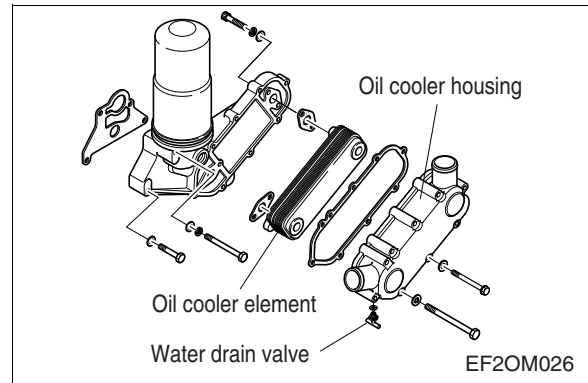

### 3.1.16. Water pump

- Unclamp the rubber hose connected to the oil cooler.
- Unscrew the water pump fixing bolts from the cylinder block and take off the water pump.

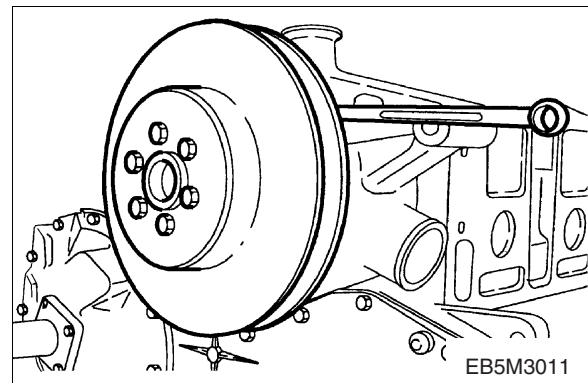

### 3.1.17. Cylinder head cover

- Remove the head cover fixing bolts and lift the cylinder head cover.

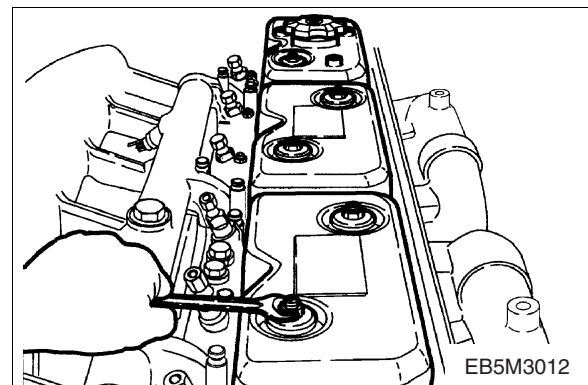

### 3.1.18. Exhaust manifold

- Unscrew the exhaust manifold fixing bolts.
- Then disassemble the exhaust manifold and gasket.
- Scrap the used gasket.



#### CAUTION:

Be careful to remove the exhaust manifold. It is very heavy.

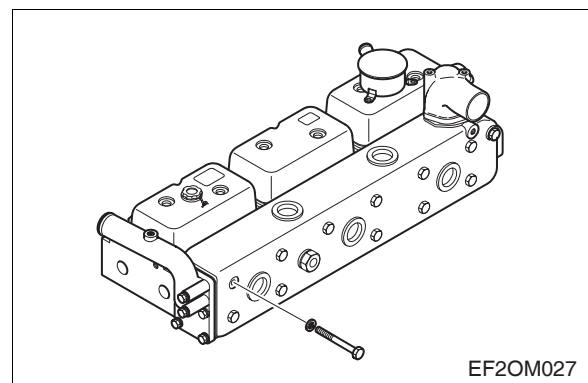

### 3.1.19. Intake manifold

- Unscrew the intake manifold fixing bolts and remove the intake manifold from the cylinder head.
- Disassemble the intake manifold gasket and discard it.

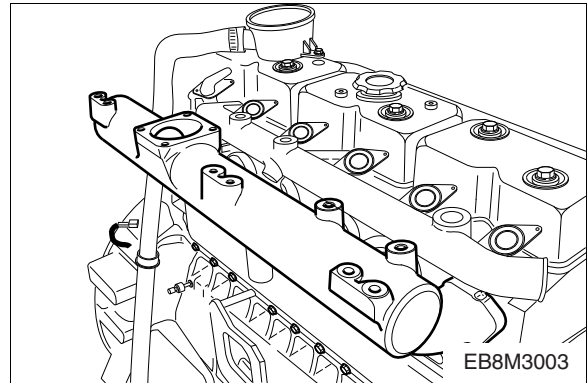

### 3.1.20. Cooling water pipe

- Unscrew the cooling water pipe fixing bolts and remove the cooling water pipe from the cylinder head.
- Remove the cooling water pipe gasket and finish the surface with a scraper.



#### CAUTION:

Be sure that piece of the gasket do not come into the cooling water passage.

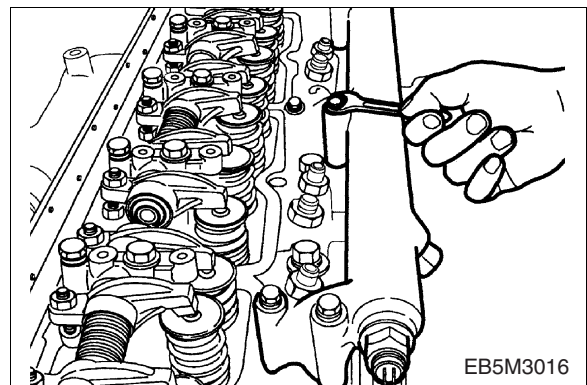

### 3.1.21. Spark plug

- Loosen the high pressure cable then remove the ignition coil.
- Remove the spark plug using socket tool.

Spark plug Socket tool	Hex. Head :16 mm (5/8 inch)
---------------------------	--------------------------------

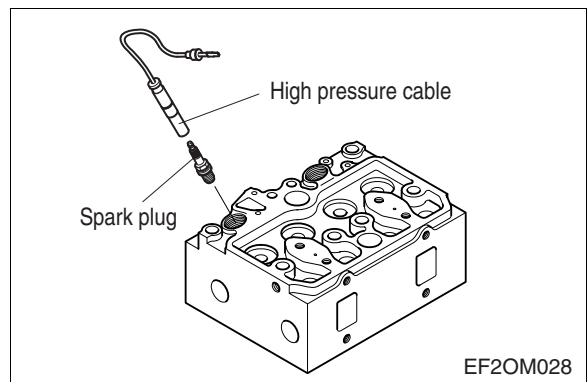

### 3.1.22. Rocker arm

- Remove the rocker arm bracket fixing bolts in reverse order (zigzag method) of assembling and disassemble the rocker arm.
- Take out the push rod upwards.
- Disassembly of rocker arm assembly
  - Remove the snap ring from the both ends of rocker arm shaft by means of a plier.
  - Remove the washer, rocker arm, bracket and spring from the rocker arm shaft in sequence.
  - Press out the rocker arm bush.

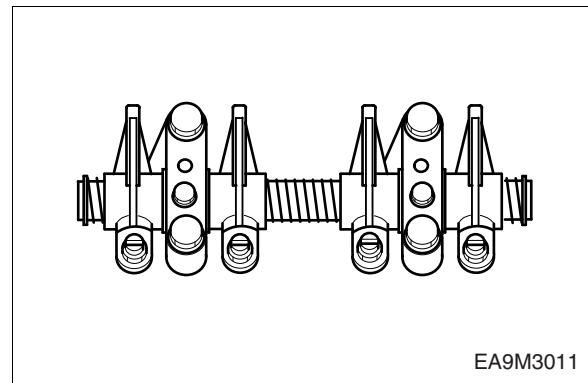

#### CAUTION :

When reassembling the bush, cool the bush in dry ice and press the bush while aligning the bush with the oil hole of the rocker arm.

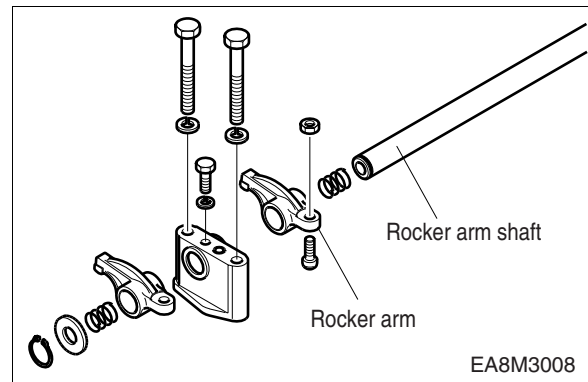

### 3.1.23. Cylinder head

- Remove the cylinder head bolts in the reverse order of tightening but remove it step by step.
  - **First step : Loosen 1 ~ 2 threads**
  - **Second step : Remove by loosening fully.**
- However, remove the total bolts simultaneously by the step of 1 and 2.
- Lay the removed bolts orderly not to damage the threads at all and store.

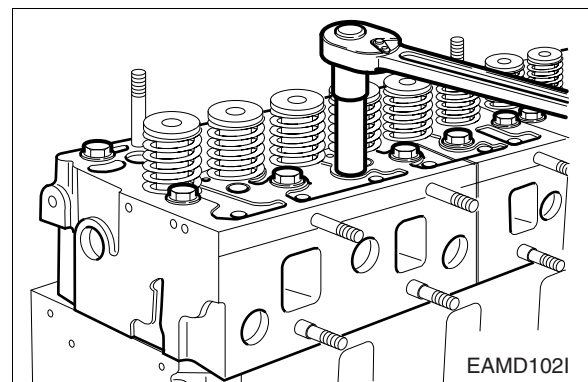

#### CAUTION:

Prevent a collision between the bolt thread each other.

- Take out the cylinder head gasket and scrap it.
- Remove the foreign residues from the cylinder head surface and block surface.



#### CAUTION:

Try not to make any damage on the contact surfaces.

### ● Disassembly of cylinder head



- Place the cylinder head on a individual shelf.
- As pressing the valve spring with a special tool, remove the cotter pin, valve spring.
- Take out the intake and exhaust valves.

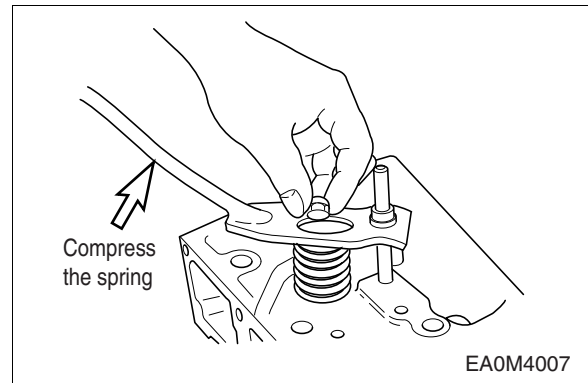

- For removal of the valve seat, apply arc welding work to two points of valve seat insert, and pull out the valve seat insert with inner extractor.



- When replacing valve guide & seat work simultaneously by special tools.

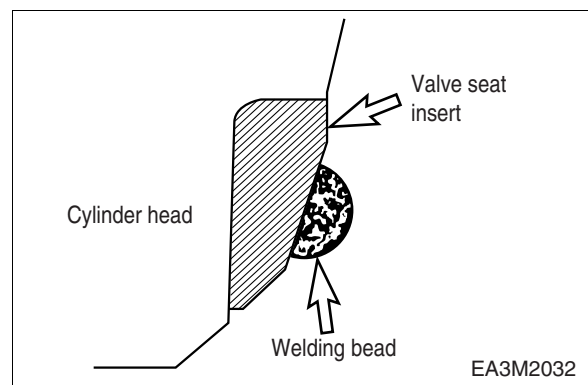

### 3.1.24. Oil pan

- Unscrew the oil pan fixing bolts and remove the oil pan.
- Remove the oil pan gasket and discard it.

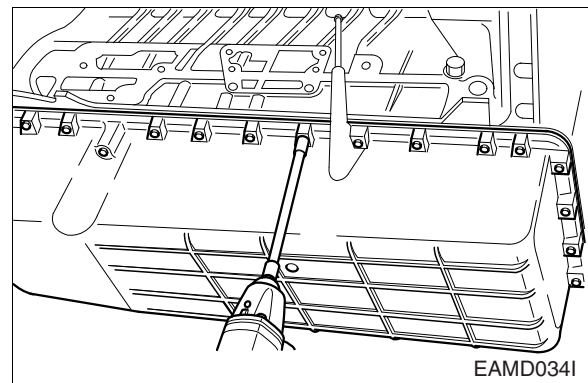

### 3.1.25. Vibration damper

- Unscrew the vibration damper fixing bolts in reverse sequence of installing sequence and remove the vibration damper assembly.

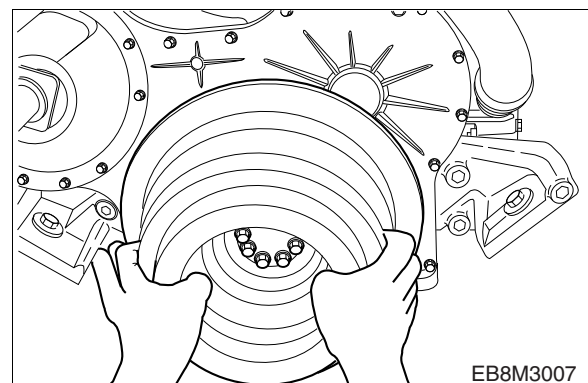

### 3.1.26. Timing gear case



- Disassemble the oil seal using an oil seal removing jig.
- Remove the cover fixing bolts and disassemble the cover from the timing gear case.

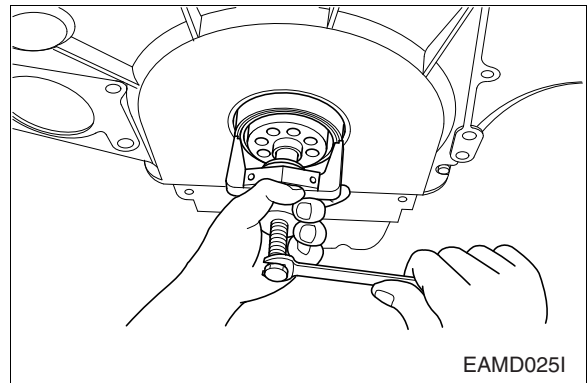

### 3.1.27. Oil pump

- Unscrew the bracket fixing bolts of the oil suction pipe.
- Unscrew the pipe fixing bolts of oil pump and disassemble the suction and supply oil pipe.
- Unscrew the oil pump fixing bolts, and disassemble the oil pump.

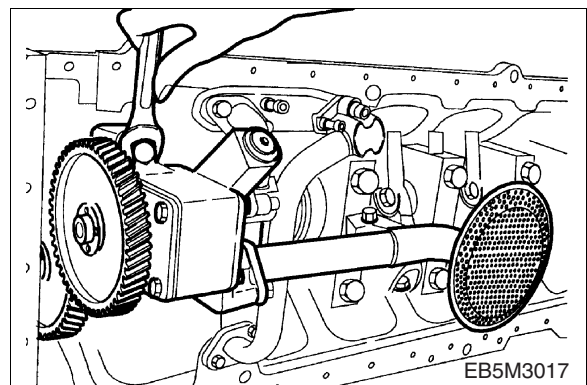

### 3.1.28. Piston and connecting rod

- Remove the connecting rod cap bolts in the reverse order of assembling but do same as the cylinder head bolt removal.
- Disassemble the upper/lower of connecting rod caps by tapping lightly with urethane hammer, and remove the bearing.
- By pushing the connecting rod with wooden bar from the direction of oil pan toward cylinder head, disassemble the piston assembly.
- The disassembled piston assembly should be handled to prevent bumping each other, and stored as the cylinder's order.



- In order for connecting rod cap not to be swapped, temporarily assemble to the corresponding connecting rod.

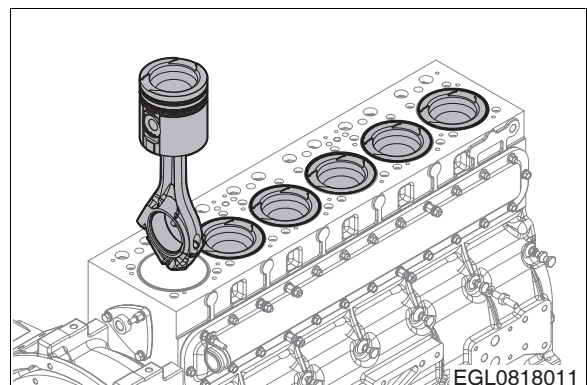

### <Disassembly of piston>



- (1) Remove the snap rings by means of a plier.

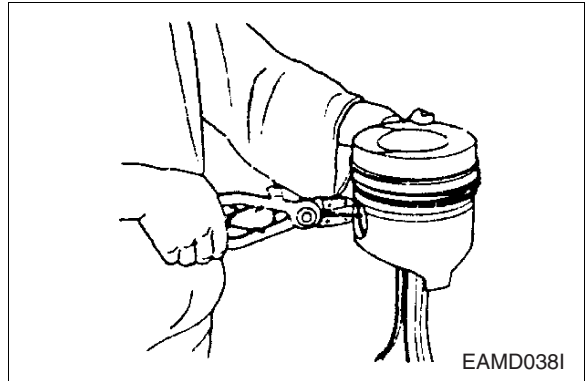

- (2) Heat the piston with an electric heater, then take out the piston pin from the piston as tapping it with a round wooden bar.

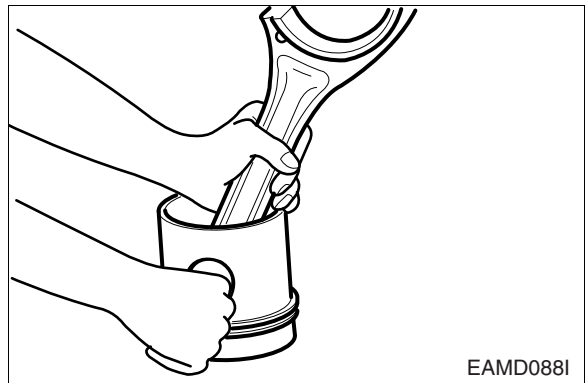

- (3) Remove the piston ring with a plier.



- (4) Clean the piston thoroughly.

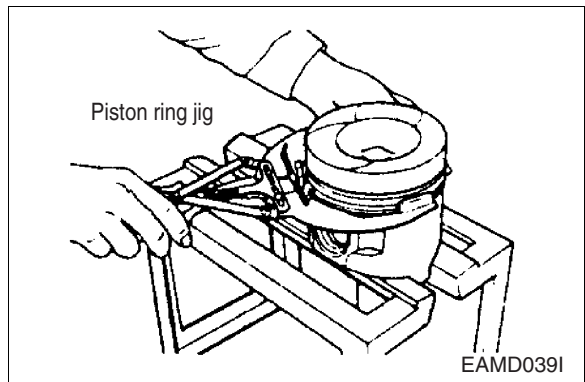

### 3.1.29. Cylinder liner



- Disassemble the cylinder liner with a special tool or hand but be careful not to generate any damage at cylinder block.

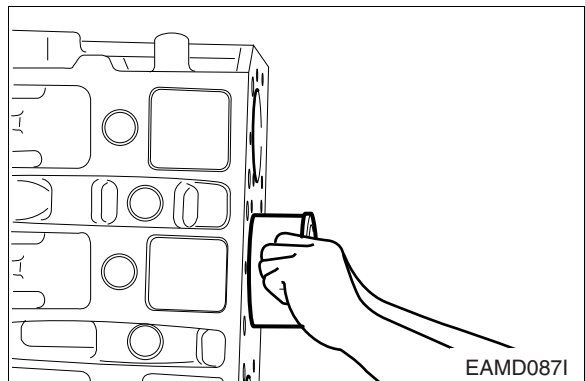

### 3.1.30. Camshaft gear and idle gear

- Unscrew the camshaft gear fixing bolts and remove the camshaft gear.

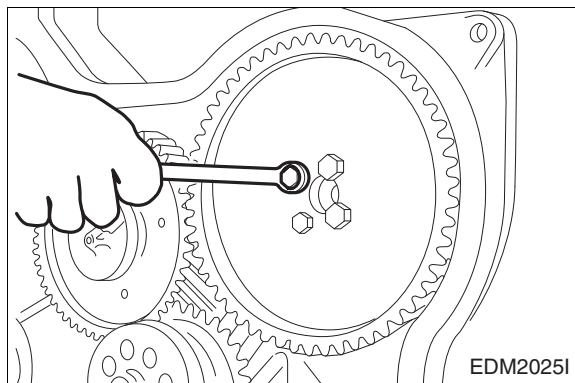

- Unscrew two bolts fixing the idle gear, then remove the idle gear and its pin.

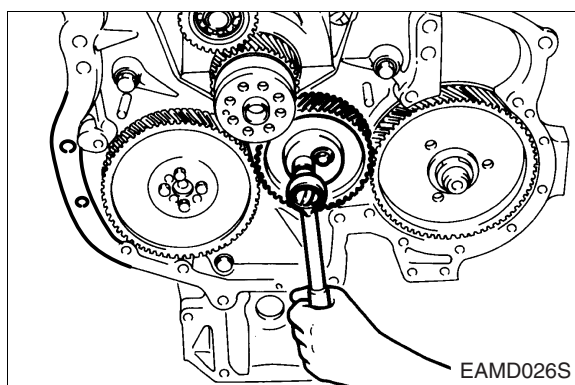

### 3.1.31. Water chamber cover

- Unscrew the fixing bolts and remove the water chamber cover.
- Remove the remnant gasket thoroughly.

### 3.1.32. Flywheel

- Remove the flywheel fixing bolts and disassemble it.
- The bolt removal is done by the reverse order of assembling and by the steps.

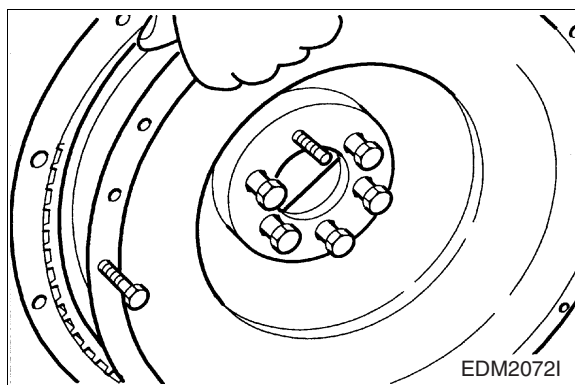

### 3.1.33. Flywheel housing

- Remove the flywheel housing fixing bolts and disassemble the flywheel housing.
- Disassemble the oil seal of flywheel housing.

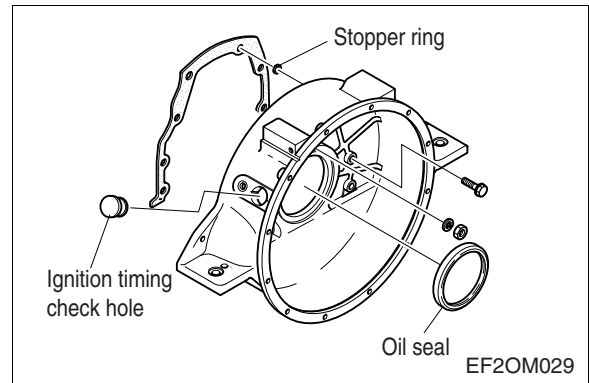

### 3.1.34. Trigger wheel & timing sensor

- Loosen the magnetic pick-up sensor fixing nut and remove the magnetic pick-up sensor.
- Remove the fixing bolts and disassemble the trigger wheel cover and trigger wheel.

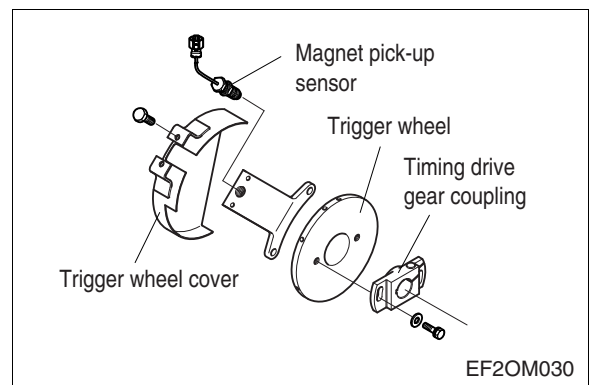

### 3.1.35. Timing drive gear

- Unscrew the drive gear housing fixing bolts and remove the drive gear assembly.

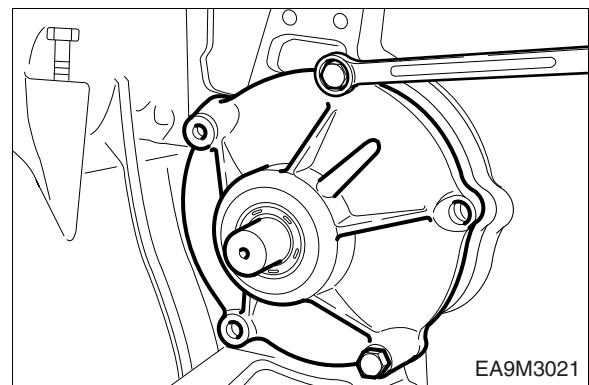

### 3.1.36. Timing gear case

- Remove the timing gear case assembling bolts.
- By tapping lightly with a urethane hammer the right and left back of timing gear case's connecting part, disassemble the timing gear case.

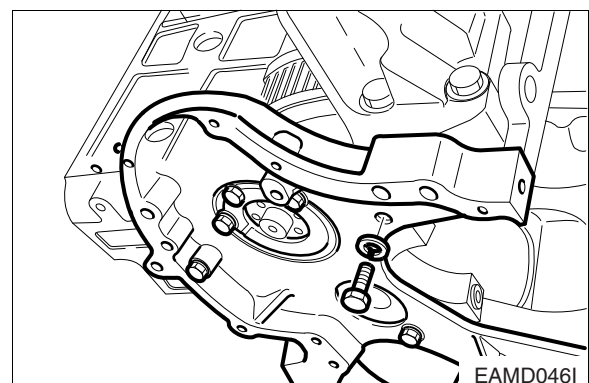

### 3.1.37. Bearing cap

- Remove the bearing cap assembling bolts by the step in the reverse order of assembling, and disassemble the bearing cap. (Remove by the same way as the cylinder head bolts' removal.)
- Disassembled bearing caps are kept laid in order.

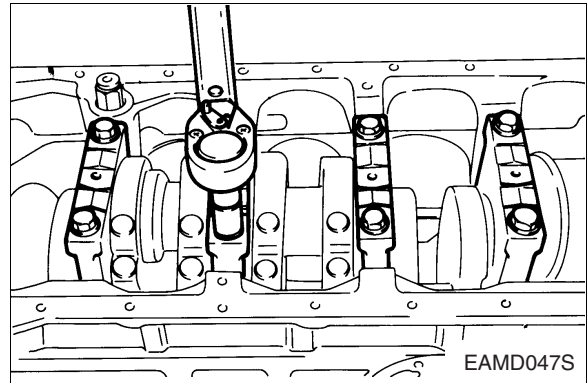

### 3.1.38. Camshaft and tappet

- In order for camshaft not to be damaged, disassemble turning it.
- In order for the disassembled camshaft to be prevented from bends or damage, put it on the special lathe and store.
- Pull out the tappet.
- As required, pull out the camshaft bush from the cylinder block by a press.
- Check for damage, scratch, wearing state and if abnormal, tear down.

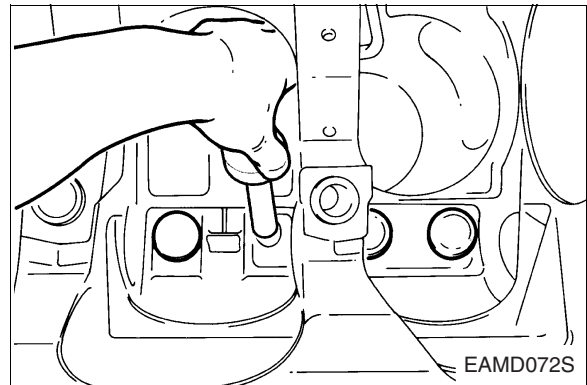

### 3.1.39. Oil spray nozzle

- Remove the valve screws of oil spray nozzle and disassemble it.

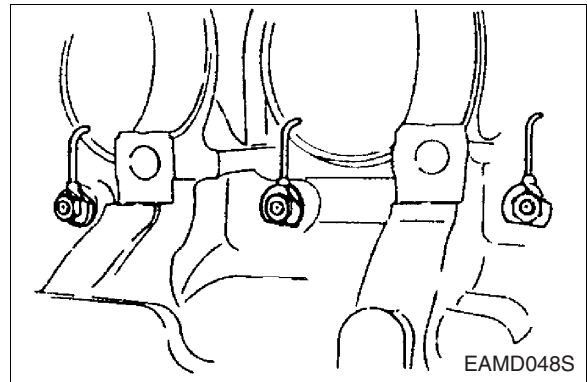

## 3.2. Inspection and measurement on major parts

### 3.2.1. Cylinder block



- Clean the cylinder block thoroughly, and check for any crack or damage.

- If there is any crack or severe damage, replace it and if there is minor one, correct it.



- Check for any clogging or corrosion in the oil passage and water passage.

- Carry out a leakage test for any crack or air leaking. (Hydraulic test)

- Plug each cylinder block's water and oil discharge ports, and apply the air pressure of about 4 kg/cm<sup>2</sup> to intake port and soak it in water for about 1 minute to check if there is any leakage. (Water temperature : 70°C)

### 3.2.2. Cylinder head

#### 1) Cylinder head assembly & disassembly

(1) Disassemble the cylinder assembly, and put it on the shelf for assembly or clean lathe.



#### CAUTION :

**Prevent any damage to gasket's contact surface of the cylinder head.**



(2) Disassemble the cotter pin, spring, spring seat pushing valve spring by a special tool.

(3) Pull out the intake and exhaust valves.

(4) The disassembled parts are kept laid in turn.

(5) Disassemble the valve stem seal.

#### 2) Inspection of cylinder head

(1) Check for the cylinder head.



- Remove carbon from the cylinder head lower surface, and then should be careful not to scratch the surface.



- Check any crack or damage that can not found by naked eyes through the hydraulic or magnetic particle test.

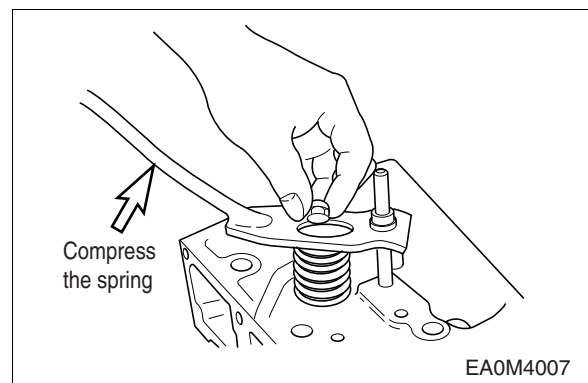

(2) Distortion of lower surface



- As shown in figure, measure the cylinder head's distortion at 6 directions with horizontal ruler and clearance gauge.
- If the measured value is beyond the limit value, correct it by means of the fine grinding paper or grinding machine.
- If it is beyond the max. allowable value, replace the cylinder head.

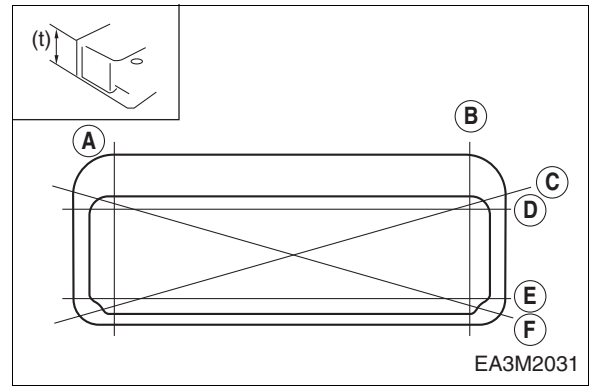

< Lower face warpage and height >

	Standard	Limit
Warpage	0.2 mm or less	0.3 mm
Thickness : t (reference)	109.9 ~ 110.1 mm	108.4 mm

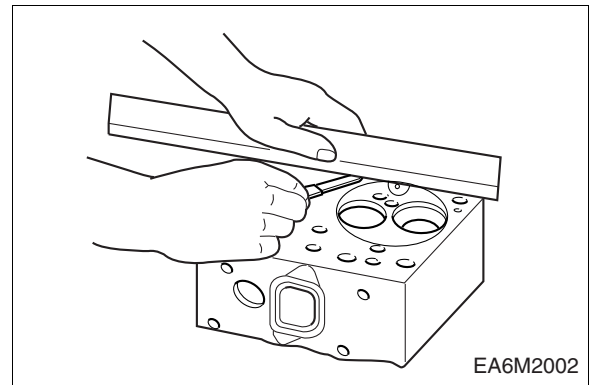

(3) Flatness



- Check the flatness of the installing surface of cylinder head's intake and exhaust manifolds with horizontal ruler and clearance gauge.

Standard	Limit
0.05 mm	0.2 mm

(4) The hydraulic test



- The hydraulic test of cylinder head is same as the cylinder block test.

### 3.2.3. Spark plug



- Remove spark plug. Clean threads by hand with brush and solvent.

- Clean any deposits from electrode and inspect insulator area



- Measure the spark plug distance at electrode position.(A)

- Correct or replace the spark plug if necessary.

Standard(A)	0.39 ~ 0.40 mm
-------------	----------------

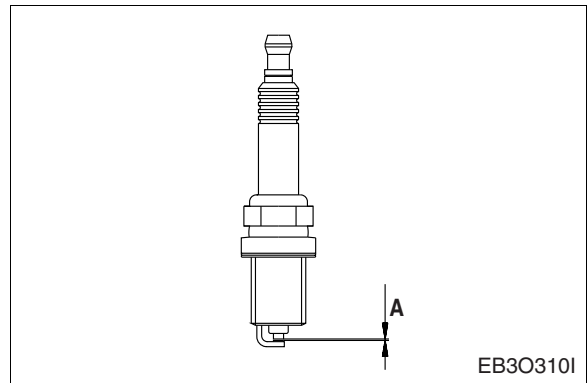

- Insert the spark plug into cylinder head and measure distance(B)



Spark plug torque	2.5 ~ 3.0 kg.m
-------------------	----------------



Standard(B)	3.38 ~ 3.76 mm
-------------	----------------

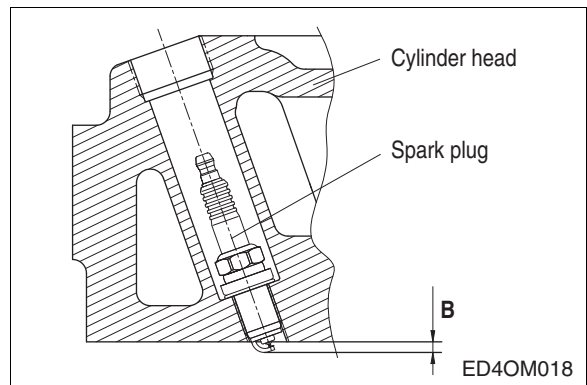

### 3.2.4. Valve and valve guide

#### 1) Valve



- After cleaning valve with fuel, check it.

- Valve stem outer diameter



Measure the valve stem outer diameter at 3 positions (top, middle, and bottom), and check for any wear and if beyond the limit value, replace the valve.

Dimension Description	Standard	Limit
Intake valve stem	$\phi 8.950 \sim \phi 8.970$ mm	$\phi 8.93$ mm
Exhaust valve stem	$\phi 8.935 \sim \phi 8.955$ mm	$\phi 8.91$ mm

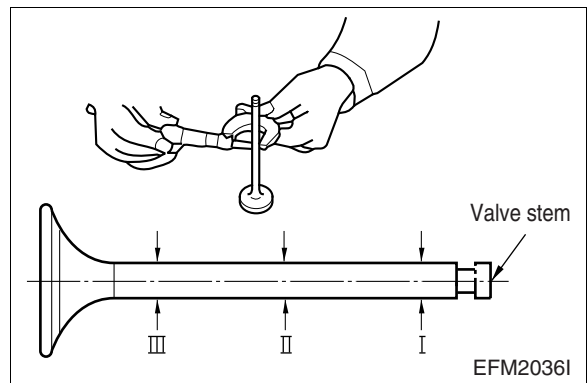

- Valve seat contacting faces



Check the valve seat contact surface for any crack and wear, and if necessary, correct with grinding paper, and if excessive, replace it.

● **Valve head thickness**



Measure the thickness of valve head and if beyond the limit value, replace the valve.

Dimension Description	Standard	Limit
Intake valve	2.7 mm	1 mm or less
Exhaust valve	2.2 mm	1 mm or less

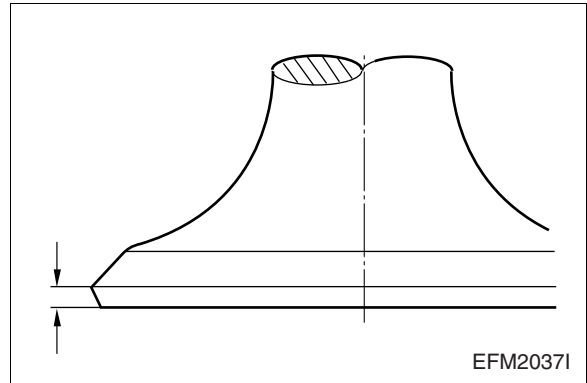

**2) Valve guide**

- Insert a valve into cylinder head and measure the clearance between valve guide and valve by valve movement. If the clearance is excessive, measure the valve and replace the excessively worn valve or valve guide.

● **Valve stem end play**



Dimension Description	Standard	Limit
Intake valve	0.04 ~ 0.07 mm	0.2 mm
Exhaust valve	0.06 ~ 0.09 mm	0.25 mm

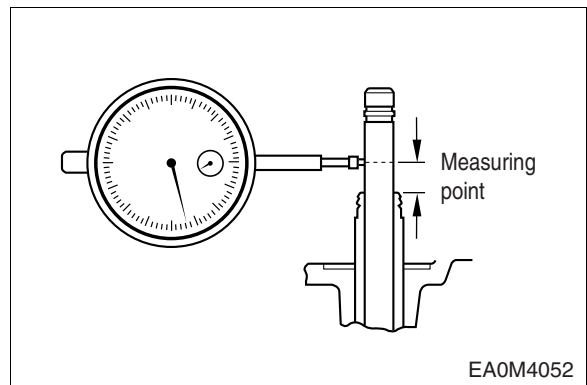

- Assemble the valve at cylinder head's valve guide and see if it is centered with the valve seat using a special tool.



**3) Valve seat**

● **Contacting face amount**



As for the valve seat's wear, measure the width of the contact surface with intake valve seat and exhaust valve seat. If beyond the limit value, replace the valve seat.

- Assemble the valve at the valve seat of the cylinder head, and check the amount of depression of the valve from the lower portion of the cylinder head using a dial gauge.

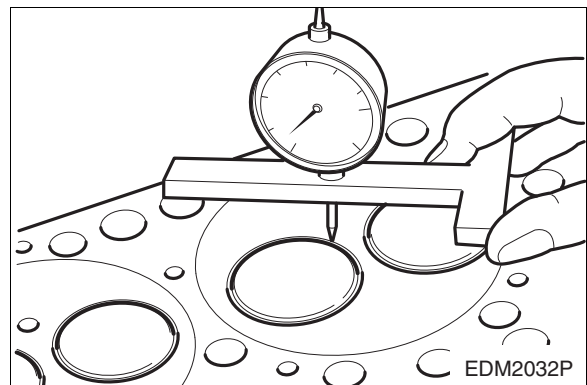

- Valve depression

If the amount of depression is beyond the specified limit, replace the valve seat.

	Standard	Limit
Intake & Exhaust	0 ~ 0.3 mm	0.55 mm

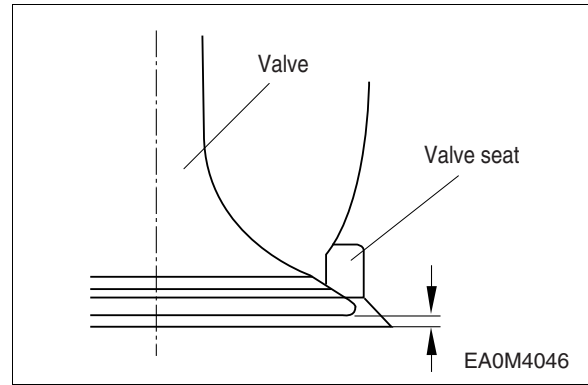

- For the disassembling of valve seat, by welding the welding bead to a valve seat rotating tool or valve seat, pull it out with a special tool.



- For the assembling of a new valve seat, by putting it among the dry ices of an ice box previously for about 2 hours for the cold shrinkage, and press it in the cylinder head by a special tool. (bench press)



- It is necessary to work boring of inner diameter of it when replace the valve seat and valve guide.
- Apply valve lapping compound to the valve head seating face on the valve seat and lap the valve seat by turning it until it is seated in position, then wipe out the lapping compound.

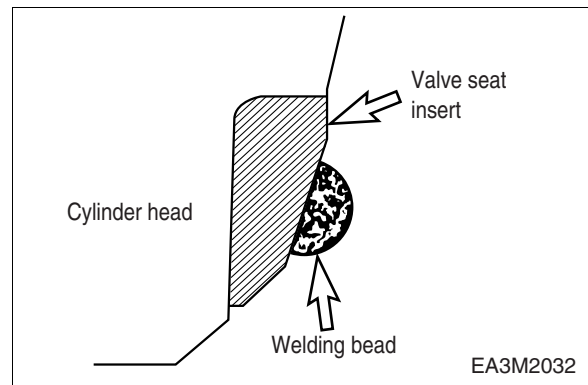

#### 4) Valve spring

- Visual check



Check the appearance of valve spring and if necessary replace the spring.

- Valve spring free length



Use a vernier caliper to measure the valve spring free length.

If the measured value is less than the specified limit, the valve spring must be replaced.

Spring free Length		Standard
Intake valve		64 mm
Exhaust valve	Inner	60 mm
	Outer	71 mm

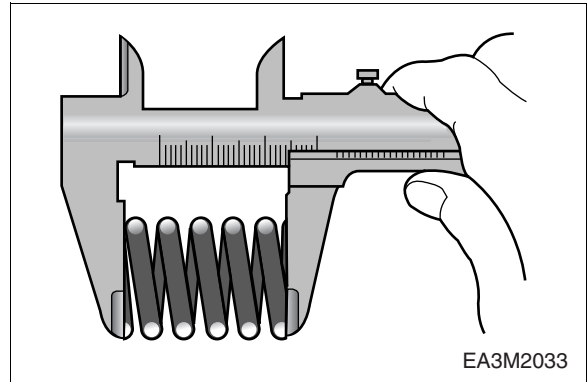

- Valve spring inclination



Use a surface plate and a square to measure the valve spring inclination.

If the measured value exceeds the specified limit, the valve spring must be replaced.

	Standard	Limit
Valve spring Inclination	Less than 1.5 mm	2.7 mm

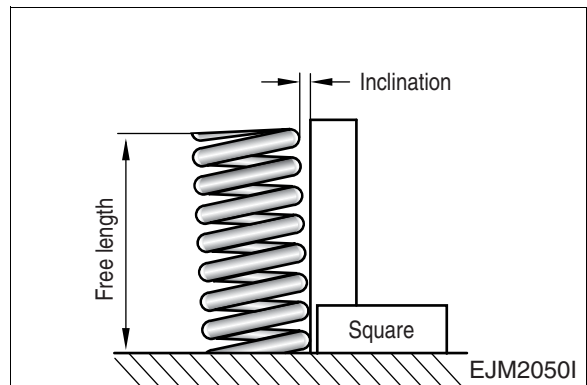

- Valve spring tension



Use a spring tester to measure the valve spring tension if the measured value is less than the specified limit, the valve spring must be replaced.

	Set Length		Spring Force	Limit
Intake Valve	Valve spring tension at 41 mm set length		70 kg	±3 kg
Exhaust valve	Inner	38 mm	28.6 kg	±6%
	Outer	41 mm	66 kg	±5%

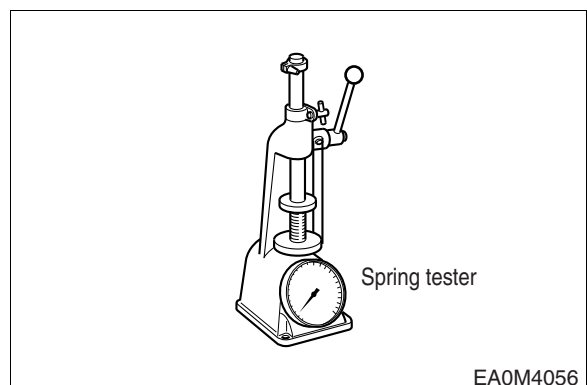

### 5) Assembling cylinder head



- Clean the cylinder head thoroughly.



- Replace the valve stem seal with new one, and by means of a special tool, press the stem seal into the valve guide of cylinder head.



- Coat engine oil to valve stem and valve guide and assemble the valve. However, be careful for the damage of valve stem seal.

- Install the lower seat of valve spring to the valve guide of cylinder head.

- After putting inner, outer springs, install the spring upper seat on it.



- Assemble the valve by inserting the valve cotter pressing the valve spring with special tool.



- After installing the valve, check whether the valve is correctly installed or not tapping it lightly with urethane hammer.

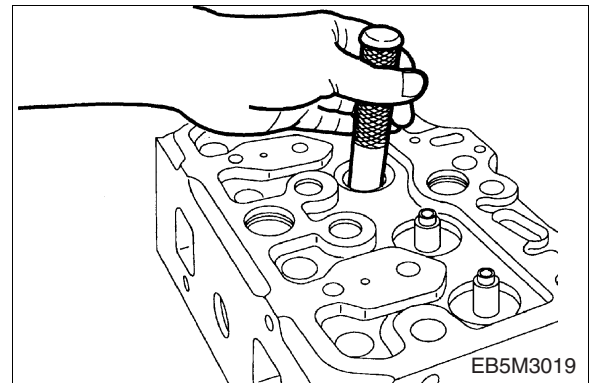

### 3.2.5. Rocker arm assembly

#### 1) Disassembly

- Disassemble the snap rings that are located at both ends of rocker arm shaft by a plier.
- Disassemble in the order of washer, rocker arm bracket, rocker arm spring, rocker arm.

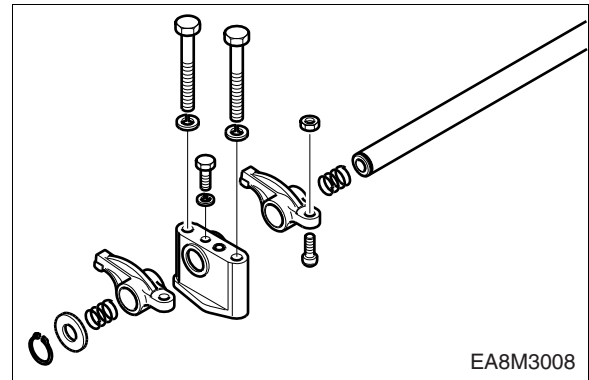

## 2) Inspection of rocker arm assembly

### (1) Rocker arm shaft

#### ● Rocker arm shaft run-out



Place the rocker arm shaft on two V blocks and inspect the shaft for bend using a dial gauge.

If the amount of this run-out is small, press the shaft with a bench press to correct the run-out.

Replace the shaft if the measured value exceeds the limit.

Limit	0.2 mm
-------	--------

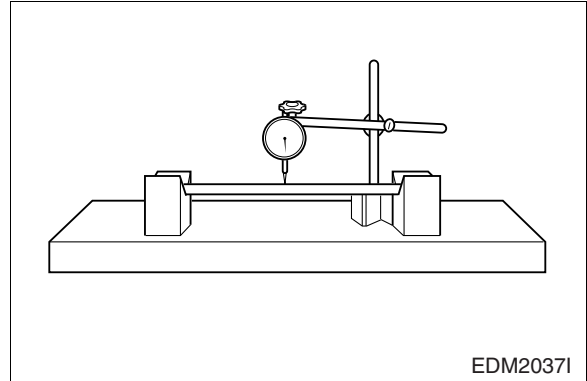

#### ● Rocker arm shaft diameter



With an outside micrometer, measure the rocker arm shaft diameter at the point where the rocker arms have been installed.

Replace the rocker arm if the amount of wear is beyond the specified limit.

Standard	Limit
$\phi 23.939 \sim \phi 23.960$ mm	$\phi 23.75$ mm

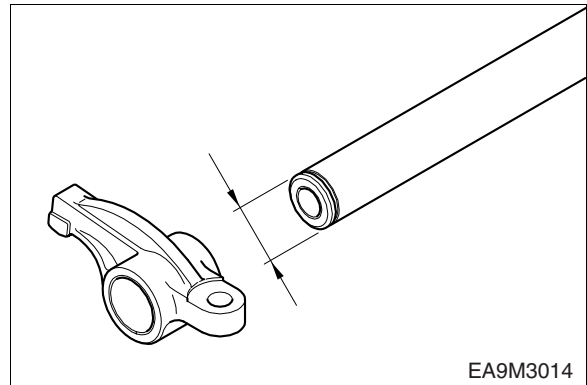

### (2) Rocker arm

#### ● Visual check



Visually check the face of the rocker arm in contact with the valve stem end for scores and step wear. If the wear is small, correct it with an oil stone or grinding paper of fine grain size. Rocker arm with a considerable amount of step wear should be replaced.

#### ● Rocker arm bushing diameter



Measure the inside diameter of the rocker arm bushing with an inside micrometer or vernier calipers, and compare the measured values with the rocker arm shaft diameter. If the clearance exceeds the limit, replace either bushing or shaft, whichever worn more.

Standard	Limit
0.040 ~ 0.113 mm	0.3 mm or less

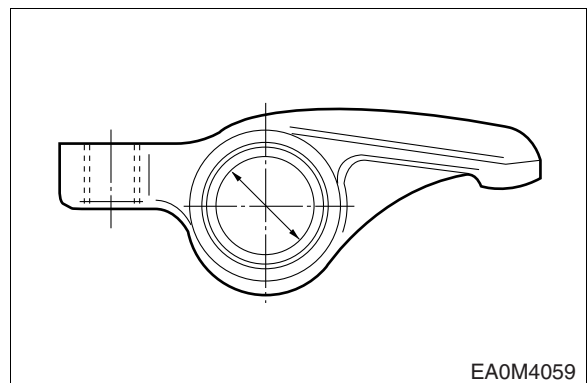

### (3) Tappet and push rod

#### ● Clearance



Measure the clearance of the tappet and tappet holes of the cylinder block. If the value is beyond the specified limit, replace tappets.

Standard	Limit
0.035 ~ 0.077 mm	0.15 mm

#### ● Visual check of tappet



Visually check the face of the tappets in contact with the cam for pitting, scores or cracks, and replace if severely damaged. If the amount of cracks or pitting is small, correct with an oil stone or grinding paper.

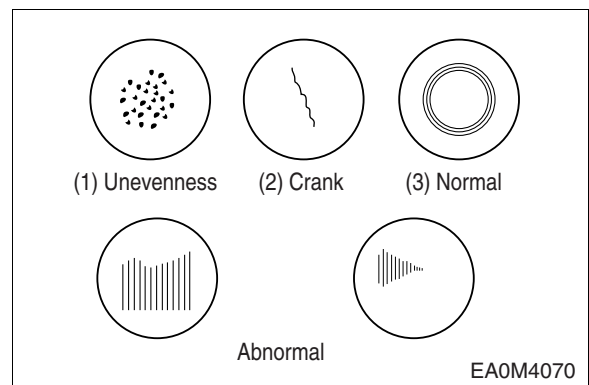

#### ● Outside diameter of tappet



With an outside micrometer, measure the tappet outside diameter. If the measured value is beyond the limit, replace tappets.

Standard	$\phi 19.944 \sim \phi 19.965 \text{ mm}$

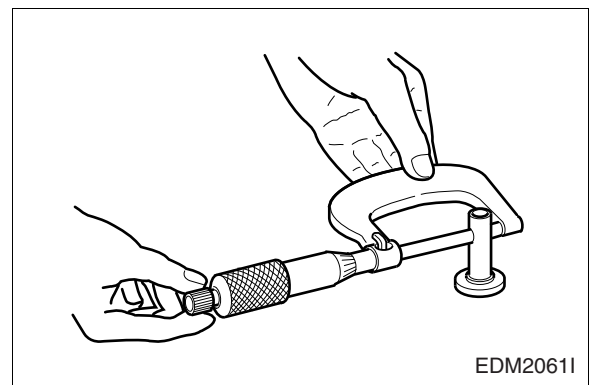

#### ● Push rod run-out



Use a feeler gauge to measure the push rod run-out. Roll the push rod along a smooth flat surface as shown in the figure

Limit	0.3 mm or less

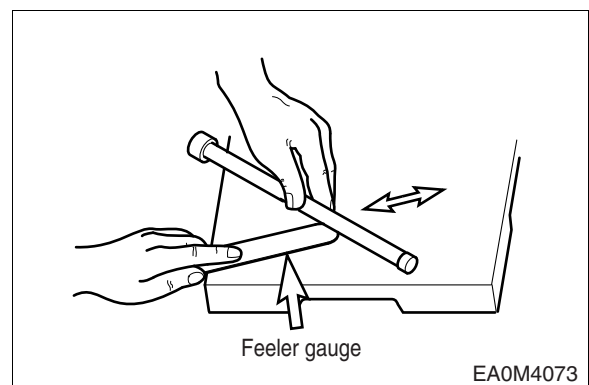

#### (4) Reassembling rocker arm assembly

Reassembling can be done in the reverse order of disassembling and following things should be heeded

- Check the oil supply hole of rocker arm shaft for any clog and clean thoroughly.
- Be careful not to occur any swap of position and reverse assembly.



### 3.2.6. Camshaft

#### 1) Camshaft end play



- Push the thrust plate toward the cam gear.
- With a feeler gauge, measure the clearance between the thrust plate and camshaft journal.
- If the end play is excessive, replace the thrust plate.

Standard	Limit
0.28 ~ 0.43 mm	0.6 mm

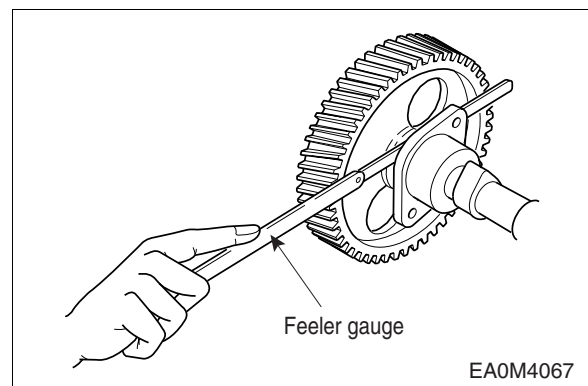

#### 2) Cam

##### ● Cam lobe height



Use a micrometer to measure the cam lobe height and journal diameter.

If the measured number is less than the specified limit, the camshaft must be replaced.

		Standard	Limit
Cam lobe Height (C)	Intake	50.50 ~ 50.70 mm	50.30 mm
	Exhaust	50.25 ~ 50.45 mm	50.10 mm
Cam journal diameter (A,B)		$\phi$ 57.86 ~ $\phi$ 57.88 mm	$\phi$ 59.56 mm

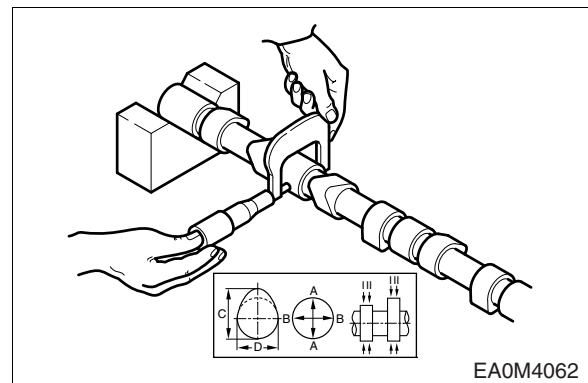

● **Cam surface**



Inspect the cam face for scratch or damage.

Slight step wear or damage on the cam face may be corrected with oil stone or oiled grinding paper. But, replace if severely damaged.

**3) Camshaft**

● **Clearance**

**Between camshaft journal and camshaft bush**

-With an outside micrometer, measure the camshaft journal diameter.



-Measure the inside diameter of the camshaft bushing on the cylinder block using a cylinder bore indicator, and compare the measured value with the camshaft outside diameter to determine the clearance.

**<Clearance>**

Standard	Limit
0.12 ~ 0.17 mm	0.24 mm

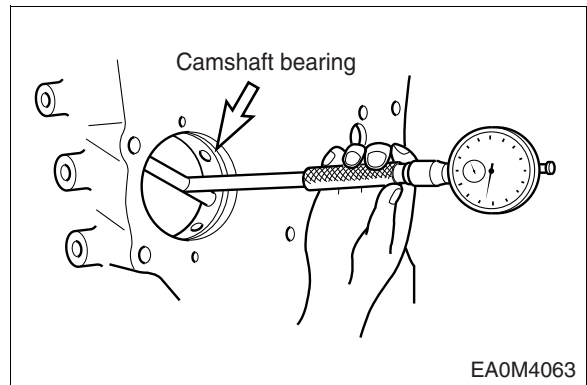

-Replace the bushing if the measured value is beyond the specified limit.

● **Run-out**



-Support the camshaft on two V blocks and check for run-out using a dial indicator.

-Correct or replace the camshaft if the amount of run-out is beyond the value indicating need for servicing.

Standard	Limit
0.05 mm	0.2 mm

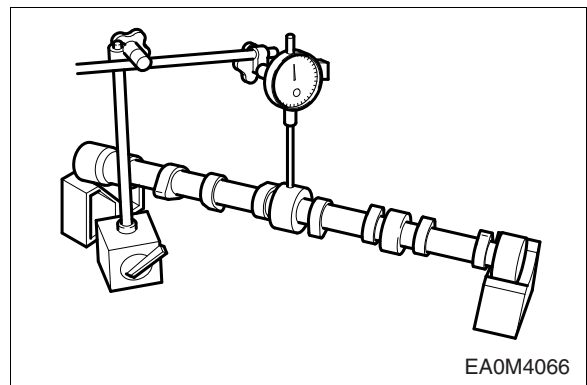

### 3.2.7. Crankshaft

#### 1) Inspection of crankshaft

##### (1) Defect check



- By naked eyes, check for any scratch or damage on the crankshaft journal and crank pin.
- By means of magnetic particle test and color check, check the crankshaft for any crack and if found, replace it.

##### (2) Wear measuring



- With an outside micrometer measure the diameter of the crankshaft journals and pins in the directions as shown, and compare the measured values to determine the amount of wear.

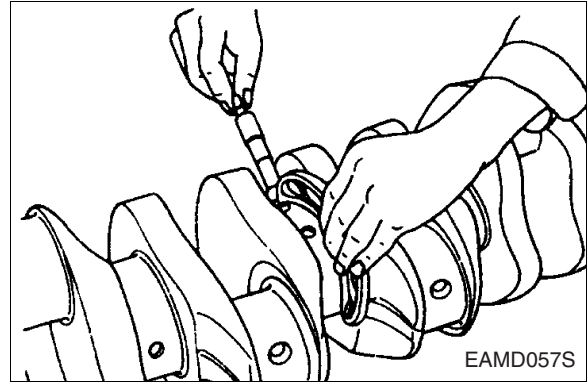

- If the amount of wear is beyond the limit, have the crankshaft ground and install undersize bearings. However, if the amount of wear is within the limit, you can correct the wear using an oil stone or oiled grinding paper of fine grain size. (Be sure to use grinding paper which has been immersed in oil.)

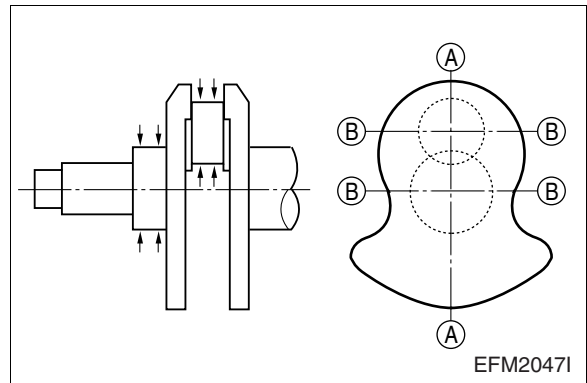

	Standard	Limit
Journal diameter	$\phi 83.966 \sim \phi 83.988 \text{ mm}$	$\phi 83.000 \text{ mm}$
Pin diameter	$\phi 70.971 \sim \phi 70.990 \text{ mm}$	$\phi 70.000 \text{ mm}$

- In case that pin's wear is more than the limit value, grind the crankshaft journal and crank pin, and use the undersized bearings.



**CAUTION:**  
Be sure to use grinding paper which has been immersed in oil.

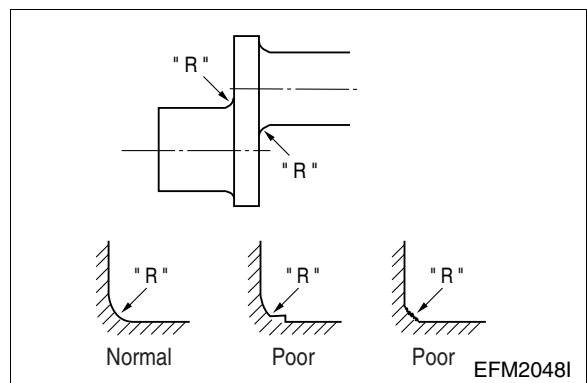

<Undersize bearings available>

▶ **Standard**

▶ **0.25 (Inside diameter is 0.25 mm lesser than the standard size.)**

▶ **0.50 (Inside diameter is 0.50 mm lesser than the standard size.)**

▶ **0.75 (Inside diameter is 0.75 mm lesser than the standard size.)**

▶ **1.00 (Inside diameter is 1.00 mm lesser than the standard size.)**

Undersize bearings are available in 4 different sizes as indicated above, and the crankshaft can be reused through the regrinding as described above.

**"R" parts specified value**

① Crank pin's "R" :  $4.5_{-0.2}^0$

② Crank Journal "R" :  $4_{-0.2}^0$



**CAUTION:**

**In case of regrinding, the grinding the "R" part of bearing end should be correctly done and keep in mind to remove any jaws or coarse surface absolutely.**

**(3) Crankshaft run-out**



- Support the crankshaft on V blocks.
- Turn the crankshaft with a dial indicator placed on the surface plate and take the amount of crankshaft run-out.

Standard	Limit
0.1 mm	0.15 mm

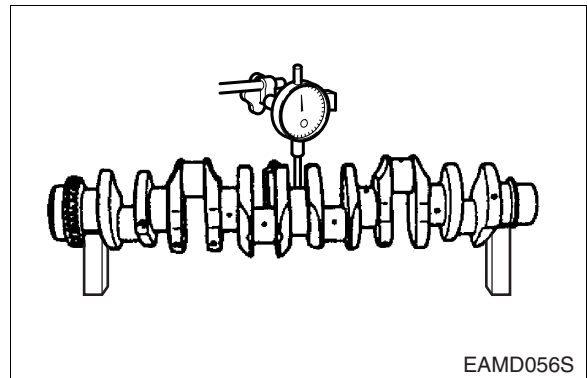

## 2) Crankshaft bearing and connecting rod

### (1) Visual check



Visually check the crankshaft bearing and connecting rod bearing for scores, uneven wear or damage.

### (2) Oil clearance between crankshaft and bearing (Method 1 : dial gauge)

#### ● Main bearing clearance



Install the main bearing in the cylinder block, tighten the bearing cap to specified torque, then measure the inside diameter.



Torque	30 kg.m
--------	---------

- Compare the two values obtained through measurement of main bearing inside diameter with the outside diameters of crankshaft journals to determine the oil clearance.

#### <Main bearing oil clearance>

Standard	Limit
0.052 ~ 0.122 mm	25 mm

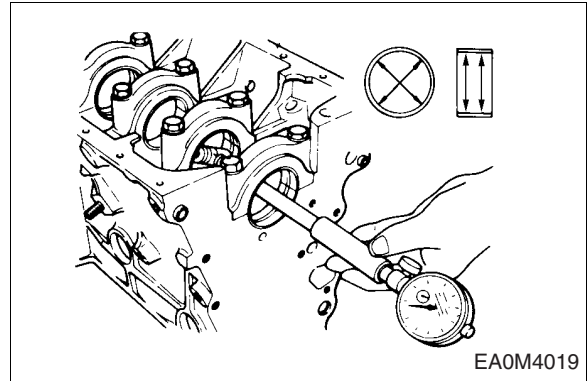

#### CAUTION:

Main bearing bolts can only be reused up to 3 times; reusing them more than that may cause damage.

### (3) Connecting rod bearing clearance



- Install the connecting rod bearing in the connecting rod bearing cap, tighten the connecting rod cap bolts to the specified torque, then measure the inside diameter.



#### <Connecting rod tightening torque>

Torque	1st Step	4 ±0.2 kgf·m
	2nd Step	60° ±3°

Note) Do not apply oil to the joint before bolting.

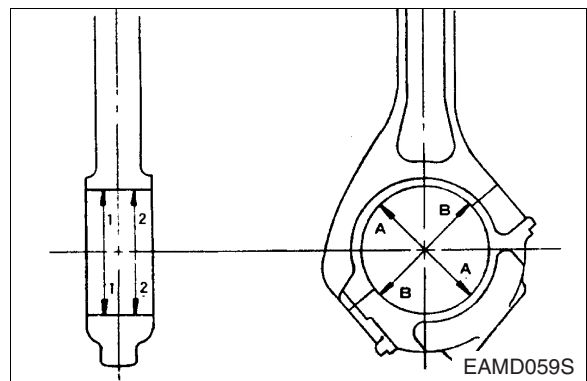

#### CAUTION:

Connecting rod bearing bolts can only be reused up to 3 times; reusing them more than that may cause damage.

- Compare the two values obtained through measurement of connecting rod bearing inside diameter with the outside diameters of crankshaft pins to determine the oil clearance.

Standard	Limit
0.034 ~ 0.098 mm	0.25 mm

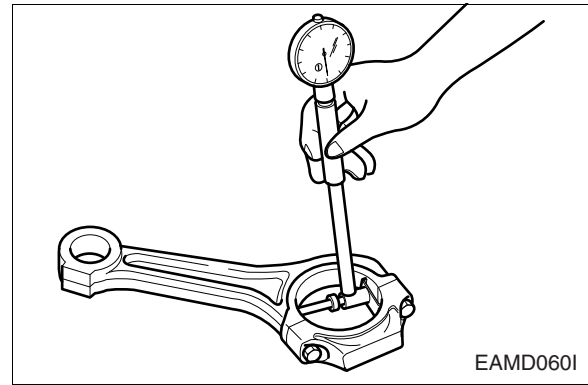

- If the clearance deviates from the specified range, have the crankshaft journals and pins ground and install undersize bearings.

#### (4) Oil clearance between crankshaft and bearing (Method 2 : plastic gauge)



- Assemble the crankshaft on the cylinder block and put plastic gauge on the journal and pin of crankshaft and then after assembling bearing cap, tighten the bolts at the specific torque. Again after disassembling the bearing cap by removing the bolts, take out the flatted plastic gauge and measure the width of plastic gauge by means of plastic gauge measuring scale. This is the oil clearance.
- The oil clearance too can be measured in the same manner



## (5) Bearing spread and crush

### ● Inspection



Check to see that the bearing requires a considerable amount of finger pressure at reassembly operation.

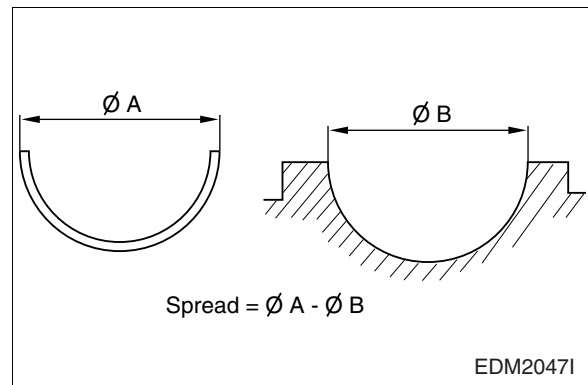
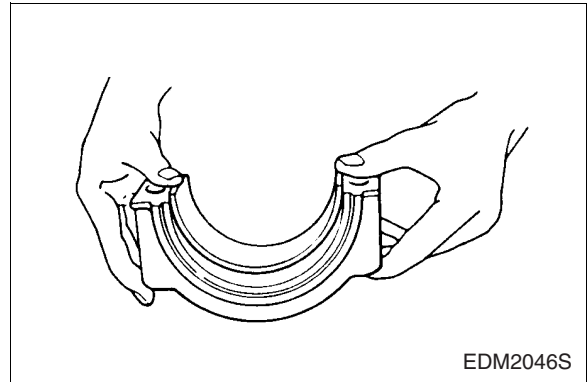

### ● Crankshaft bearing crush



Install the bearing and cap in the cylinder block, retighten the bolts to specified torque, unscrew out one bolt completely, then measure the clearance between the bearing cap and cylinder block using a feeler gauge.

Standard	0.08 ~ 0.110 mm
----------	-----------------

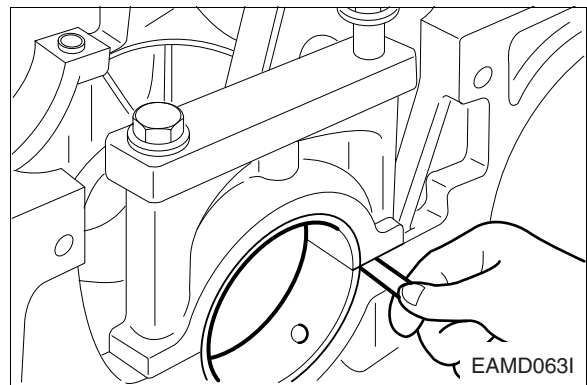

● **Connecting rod bearing crush**



Install the bearing and cap in the connecting rod big end, retighten the bolts to specified torque, unscrew out one bolt completely, then measure the clearance between the bearing cap and connecting rod big end using a feeler gauge.

Standard	0.04 ~ 0.07 mm
----------	----------------

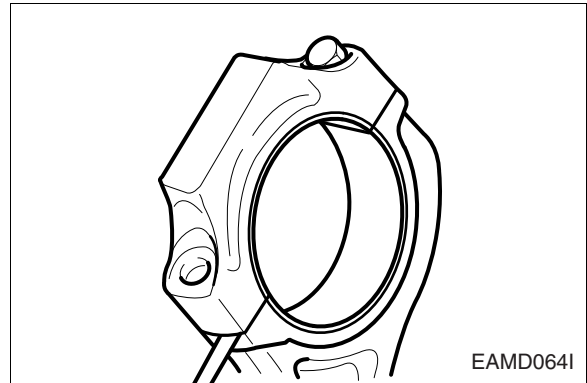

**(6) Crankshaft end play**



- Assemble the crankshaft to the cylinder block.
- With a dial gauge, measure crankshaft end play.

Standard	Limit
0.100 ~ 0.289 mm	0.5 mm

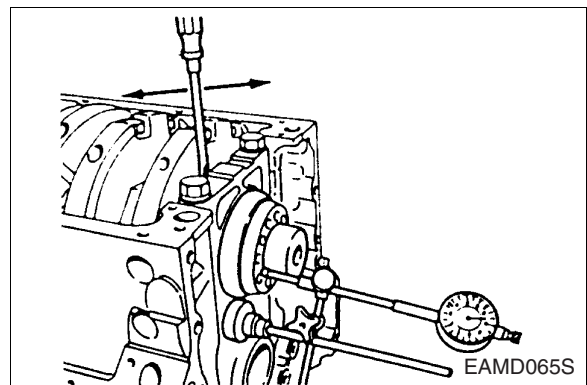

**3.2.8. Piston assembly**

**1) Disassembly of piston assembly**

Disassemble piston according to the disassembly process.

**2) Piston inspection**

**(1) Visual check**



Visually check the pistons for cracks, scuff or wear, paying particular attention to the ring groove.

**(2) Clearance between the piston and cylinder liner**



- With an outside micrometer, measure the piston outside diameter at a point 13 mm away from the lower end of piston skirt in a direction at a right angle to the piston pin hole.

Standard	$\phi$ 110.883 ~ $\phi$ 110.897 mm
----------	------------------------------------

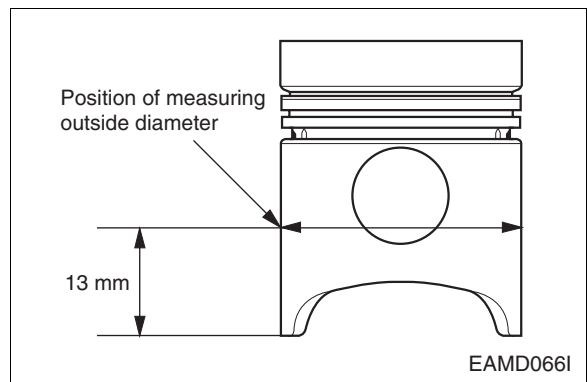



- Using a cylinder bore gauge, measure cylinder liner inside diameter at 3 points (cylinder top ring contacting face, middle, and oil ring contacting face on BDC) in a direction at an angle of 45°.
- Take the mean value with the largest and smallest values excepted.

Standard	Limit
$\phi 111 \sim \phi 111.022$ mm	$\phi 111.122$ mm

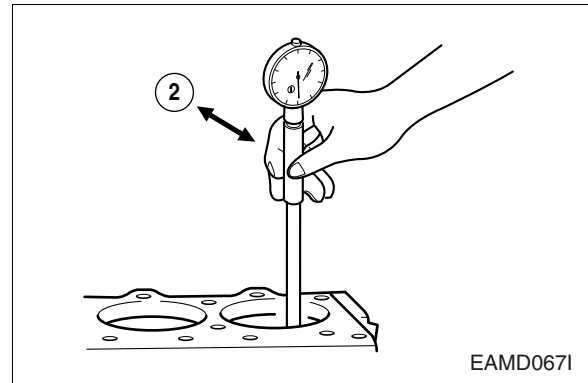

- The clearance is computed by subtracting the piston outside diameter from the cylinder liner inside diameter.
- Replace either piston or cylinder liner, whichever damaged more, if the clearance is beyond the specified limit.

< Clearance between piston and liner >

Standard	Limit
0.103 ~ 0.139 mm	0.3 mm

### 3) Piston rings

#### (1) Visual check



Replace the piston rings with new ones if detected worn or broken when the engine is overhauled.

## (2) Piston ring gap

- Insert the piston ring into the upper portion of the cylinder liner bore so that it is held at a right figure to the cylinder liner wall.
- Measure the piston ring gap with a feeler gauge.



	Standard	Limit
Top ring	0.40 ~ 0.60 mm	1.5 mm
2nd ring	0.80 ~ 0.85 mm	1.5 mm
Oil ring	0.30 ~ 0.50 mm	1.5 mm

- Replace piston rings with new ones if the gap is beyond the limit

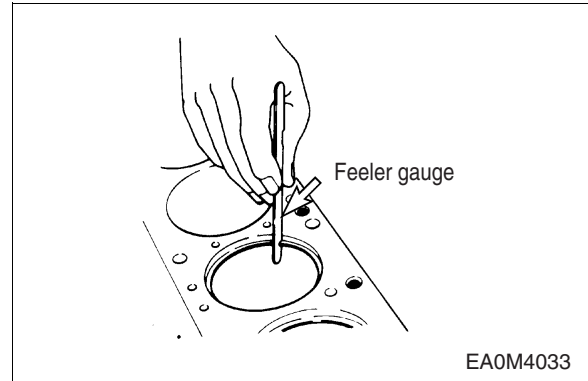

## (3) Piston ring side clearance

- Fit the compression ring and oil ring in the piston ring groove.
- With a feeler gauge, measure side clearance of each ring, and replace either the ring or piston if the measured value is beyond the specified limit.



	Standard	Limit
Top ring	-	-
2nd ring	0.07 ~ 0.102 mm	0.15 mm
Oil ring	0.05 ~ 0.085 mm	0.15 mm

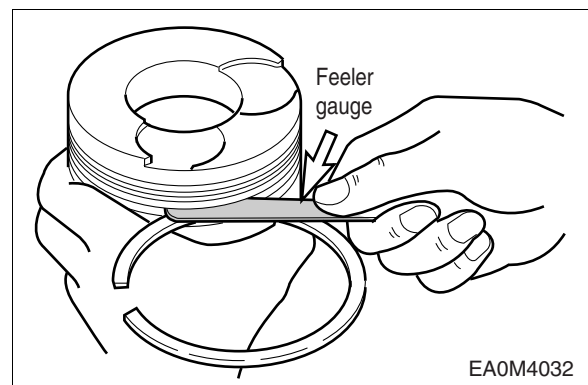

## (4) Piston ring tension

- With a tension tester, measure piston ring tension.
- Replace the piston ring if the measured value is beyond the limit.



	Standard
Top ring	2.58 ~ 3.88 kg
2nd ring	1.81 ~ 2.71 kg
Oil ring	3.57 ~ 5.05 kg

#### 4) Piston pin inspection

##### (1) Wear



Measure the amount of wear on the piston pin at the points as shown. The measured values are beyond the limit (0.08 mm or greater), replace the pin.

Standard	Limit
$\phi 41.994 \sim \phi 42.000 \text{ mm}$	$\phi 41.94 \text{ mm}$

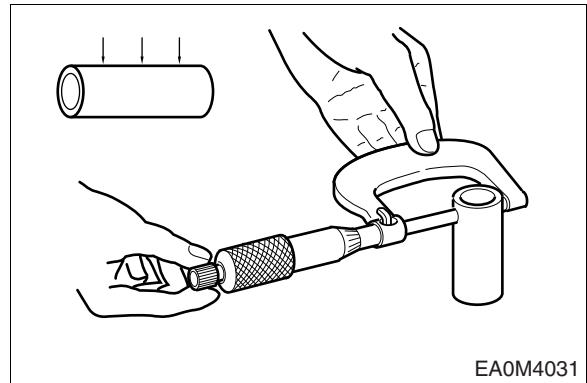

##### (2) Clearance



Measure the clearance between the piston pin and piston pin hole bushing, and replace either of them, whichever damaged more, if the measured value is beyond the limit

Standard	Limit
0.003 ~ 0.015 mm	0.08 mm

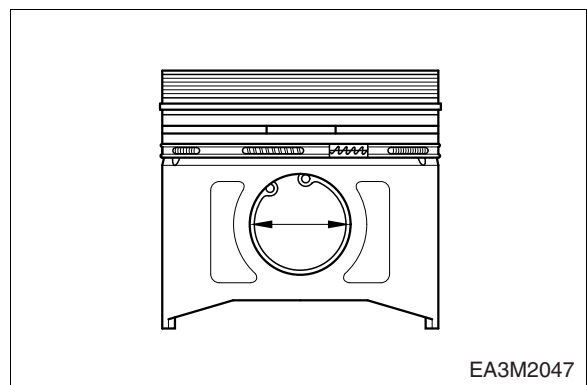

##### (3) Condition check



Check the engaged condition of the piston and piston pin. If it is possible to force the pin into the piston heated with piston heater, the piston is normal. When replacing the piston, be sure to replace the piston pin together.

#### 5) Connecting rod inspection

##### (1) Distorsion



Check the connecting rod for distortion. As shown in the figure below, install the connecting rod to the connecting rod tester, and check for distortion using a feeler gauge. If the connecting rod is found distorted, never re-use it but replace with a new one.

## (2) Holes alignment (parallelism)



Measure the alignment of the connecting rod piston pin bushing holes with connecting rod big end holes. At this time also, use both connecting rod tester and feeler gauge.

Standard	Limit
0.05 mm	0.1 mm or less

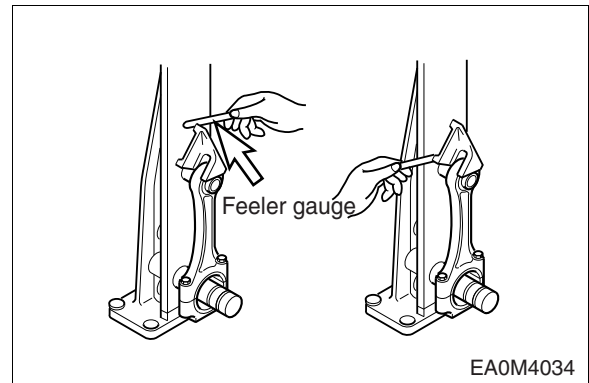

## (3) Wear



- Assemble the connecting rod to the crankshaft and measure connecting rod big end side clearance using a feeler gauge.
- Assemble the connecting rod to the piston and measure connecting rod small end side clearance.
- If the measured values are beyond the limit, replace the connecting rod.

Limit	0.5 mm
-------	--------

### 3.3. Engine reassembly

#### 3.3.1. General precautions



- Clean all the disassembled parts, particularly oil and water ports, using compressed air, then check that they are free from restrictions.
- Arrange the general and special tools in order for engine assembly operation.
- To wet each sliding part, prepare the clean engine oil.
- Prepare service materials such as sealant, gaskets, etc.
- Discard used gaskets, seal rings, and consumable parts, and replace with new ones.
- Apply only the specified torque for bolts in the specified tightening order and avoid over-tightening.
- Be sure to check that all the engine parts operate smoothly after being reassembled.
- Check the bolts for looseness after reassembly.
- After completing the engine reassembly operation, check if there is missing parts or shortage of parts.
- Keep your hands clean during the working.

#### 3.3.2. Cylinder block

- Cover the floor of the workshop with wood plate or thick paper to prevent damage to the cylinder head and place the cylinder block with the head fitting surface facing downward.

#### 3.3.3. Oil spray nozzle



- Tighten and assemble the oil spray nozzle flange with fixing bolts using the spray nozzle jig.

Torque	4.5 ±0.45 kg.m
--------	----------------

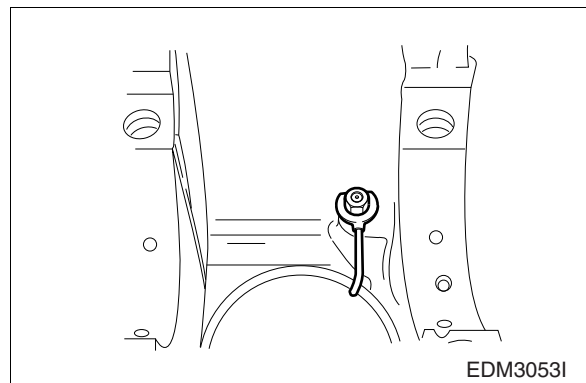

#### 3.3.4. Tappet and camshaft



- Undercool a new bush with dry ice for about 2 hours and press it into position in the cylinder block using a bench press.
- After the pressing operation, measure the inside diameter of the cam bush to check if it is not deformed.



- Apply engine oil to the entire face of the tappets and slide them into the tappet holes on the cylinder block.

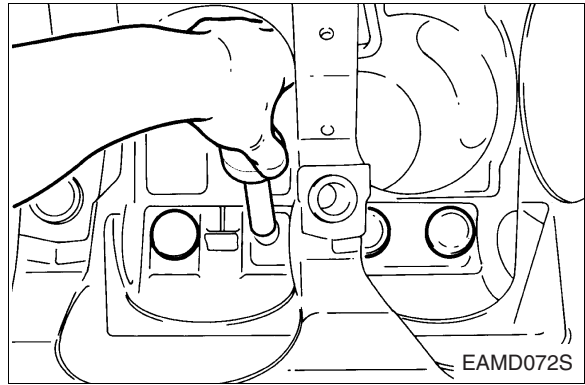

- Wet the cam bush inside diameter and camshaft with oil, and carefully assemble them while turning the camshaft.



**CAUTION:**

**Be careful not to generate a damage to camshaft and bush.**



- Check to see that the camshaft rotates smoothly.

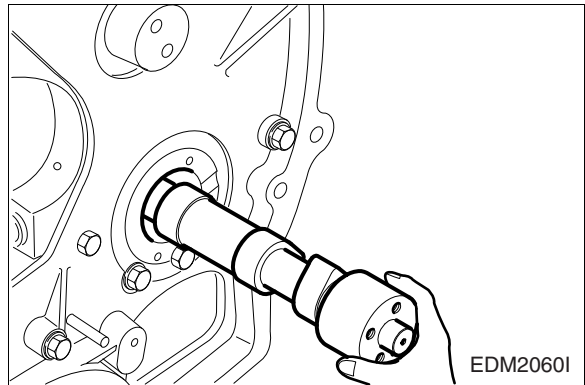

### 3.3.5. Crankshaft



- Install the main bearing (refer to assemble sequence : right figure) machined with two holes in the cylinder block so that the key is aligned with the key groove, then apply oil to the bearing surface.

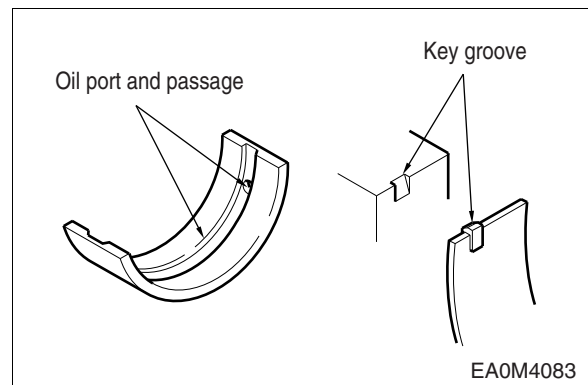
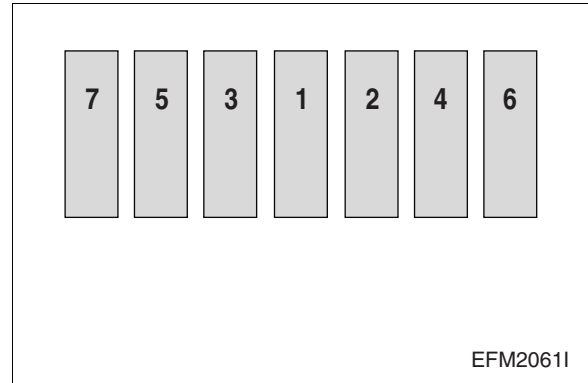

- Heat the crankshaft gear for at least 10 minutes to 120°C, then apply sealant (Loctite # 641) to the inside wall of the heated crankshaft gear evenly before inserting it to the end of crankshaft.

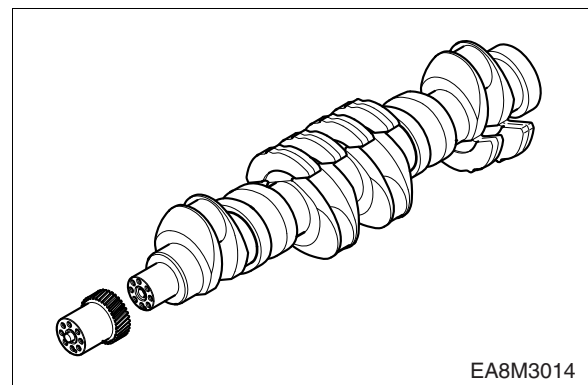

- Semi-tighten a bolt at both sides of the crankshaft, apply engine oil to journals and pins, then assemble the crankshaft with the cylinder block by tightening the fixing bolts.



- Coat engine oil to the pin and journal of crankshaft.

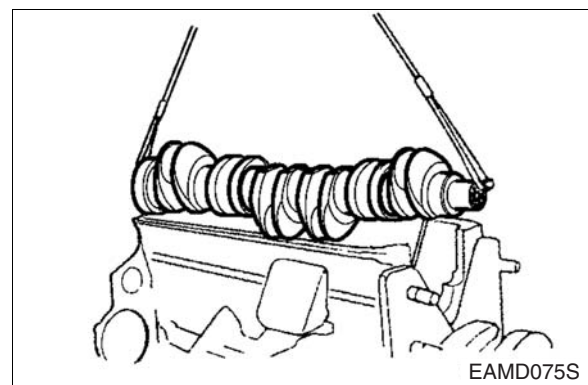



- Install the oiled thrust washers with the oil groove facing outward.

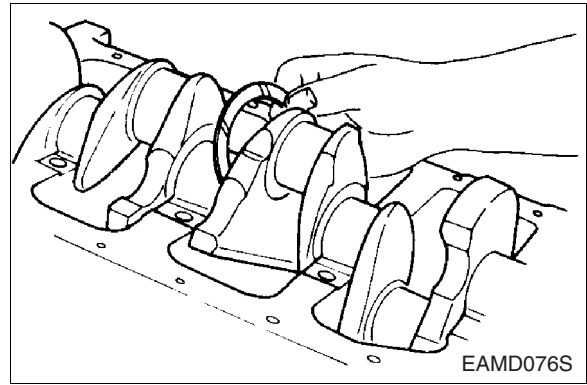

- Install the bearing and thrust washers to the bearing cap and apply oil to the bearing and thrust washers.

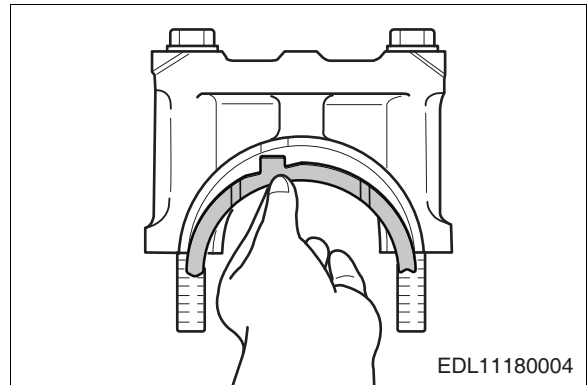

- Install the bearing cap by matching the cylinder block No. with the bearing cap No.

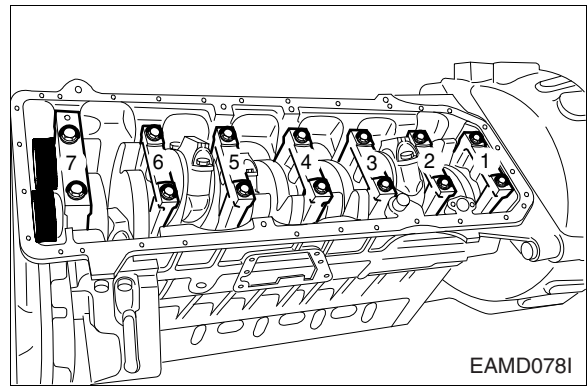

- Tighten in tightening sequence to specified torque.



Torque	30 kg.m
--------	---------



- After semi-tightening both bolts evenly, tighten them diagonally to the specified torque using a torque wrench as follows.

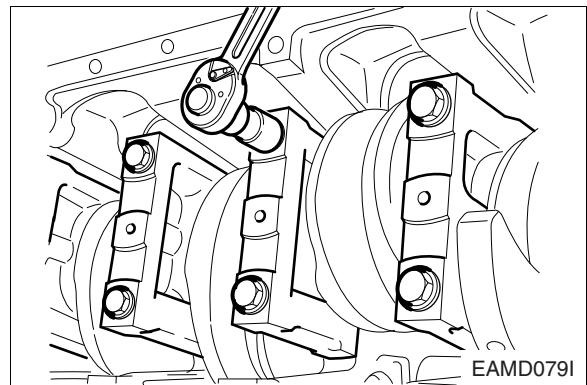

### <Tightening Order>

- (1) **First stage** : Temporary bolt screwing about 1 ~ 2 threads
- (2) **Second stage** : With impact wrench, tighten up to about 15 kg.m
- (3) **Third stage** : With torque wrench, tighten up to about 25 kg.m
- (4) **Fourth stage** : By means of torque wrench, tighten finally in the specified torque. (30 kg.m).



- Tighten the bearing cap in the sequence of 4 - 3 - 5 - 2 - 6 - 1 - 7.
- Check to see that the assembled crankshaft turns smoothly with hand.

### 3.3.6. Flywheel housing

- Temporarily install the guide bar on the cylinder block.
- Apply gasket to the cylinder block.
- Using the dowel pin and guide bar, install the flywheel housing and tighten the fixing bolts in a diagonal sequence to specified torque. (Zigzag method)



Torque	11.2 ±1.6 kg.m
--------	----------------

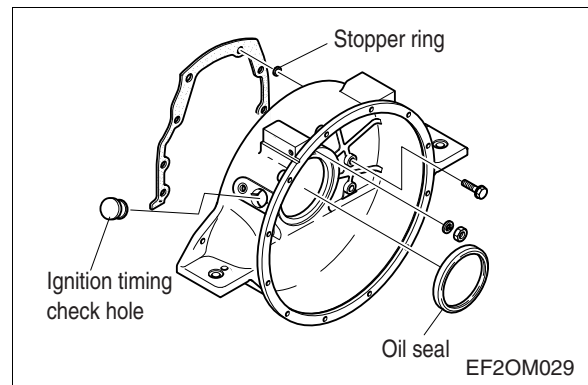

- When the bolts are tightened, remove the guide bar.
- The flywheel housing is assembled after the new oil seal was pressed (Coat engine oil over the outside of oil seal) before in the housing by a press.
- If any peripheral scar was generated due to oil seal at the oil seal contact surface of crankshaft, after inserting about 1 mm shim or thereabout in front of oil seal (Direction toward crankshaft.), measure and adjust.

### 3.3.7. Oil seal (rear side)



- Apply lubricating oil to the outside of the oil seal and flywheel housing inside diameter and fit them over the crankshaft, then assemble the oil seal using an oil seal fitting jig.

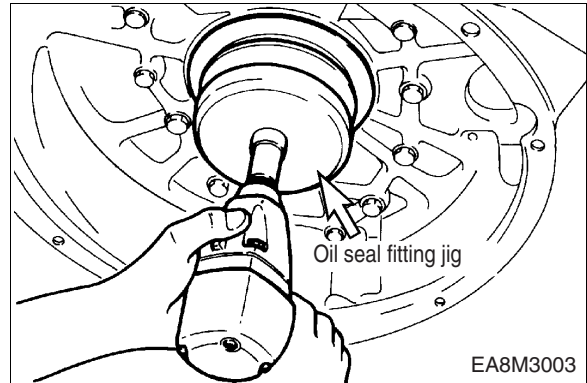

### 3.3.8. Flywheel and ring gear

- Installation of flywheel ring gear With a gas burner, heat the ring gear evenly until heat expansion takes place, then install it using a hammer.



**NOTE:**

**Do not allow the temperature of the ring gear to exceed 200°C (390°F).**

- By means of mandrel, assemble pilot bearing to the flywheel.

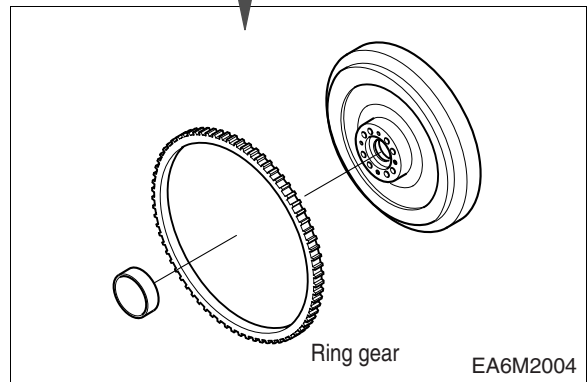
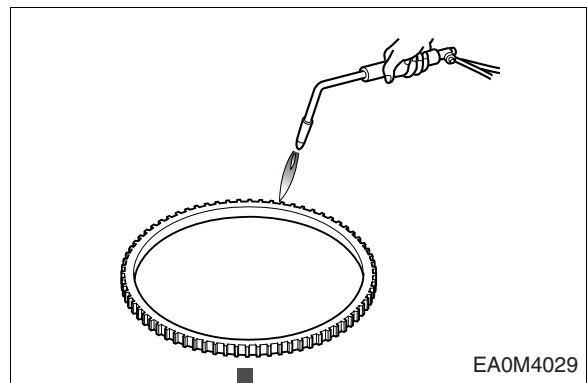



- Install a guide bar into a bolt hole on the crankshaft, and lift the flywheel to align the dowel pin with the pin hole on the flywheel for temporary assembly operation.
- Coat the adhesive (#271 Loctite) over the assembling bolts and install bolts in the remaining holes. After that take out the guide bar, then install a bolt in the hole where the guide bar had been inserted.



- According to the order of tightening tighten the fixing bolts using a torque wrench in a diagonal sequence to specified torque.

Torque	18.5 ±4.6 kg.m
--------	----------------



**CAUTION:**  
Flywheel fixing bolts can only be reused up to 3 times; reusing them more than that may cause damage.

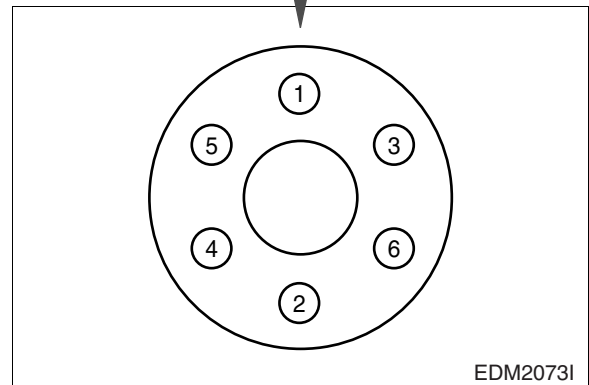
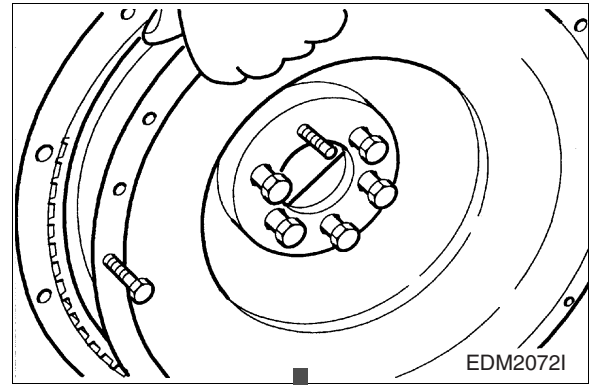

### 3.3.9. Water chamber cover

- Coat the adhesive over the water chamber cover (Particular around bolt holes) and after attaching the gasket, assemble it to the cylinder block using the bolts for assembling.
- As for tightening of bolts, after primarily tightening the bolts located at the both ends of cover (4ea at both sides) and middle bolts (Upper, lower 2ea), tighten the rest.

### 3.3.10. Cylinder liner

- Stand the cylinder block so that the flywheel faces downward.
- Thoroughly clean the liner flange fitting surface and bore inside with compressed air to prevent the entry of foreign substances.
- After the cleaning operation, make the cylinder liner dried up and push it into the cylinder block by hand.



- Wet the liner inside diameter with engine oil.

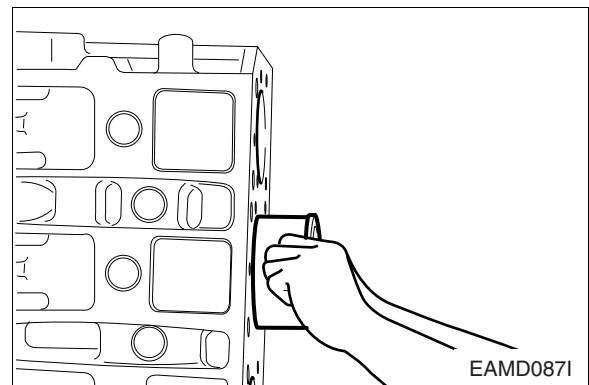

### 3.3.11. Piston and connecting rod



- Use a piston heater to heat the piston approximately 100°C (212°F) for 5 minutes.

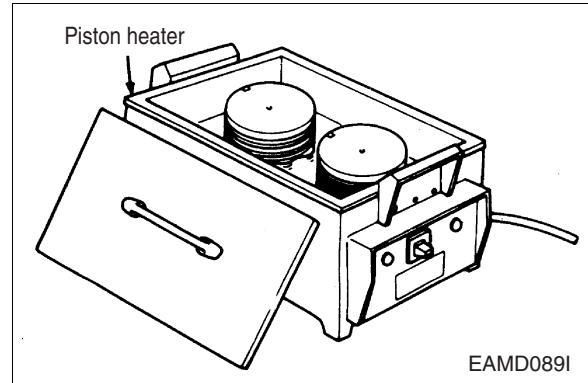

- Align the piston pin hole with the oiled connecting rod small end and press the piston pin (by lightly tapping with a rubber hammer) to assemble the connecting rod with the piston.

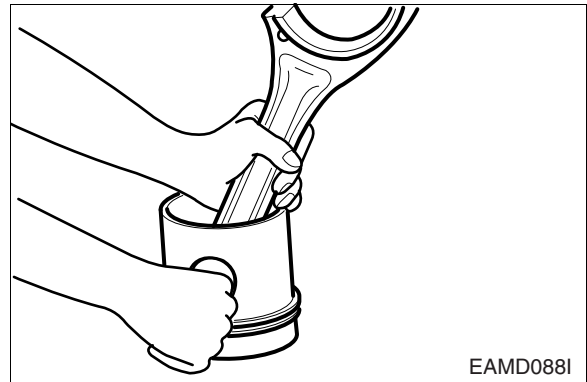

- Nothing the direction of the piston, make the longer side(machined with key groove on the bearing) of the connecting rod big end.



- On the piston head surface, the longer side connecting rod big end is in opposite direction from the valve seating surface as well as in the same direction with the narrow margin of the combustion chamber.

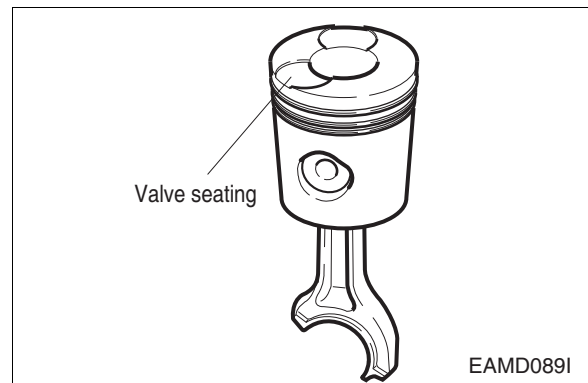



- Install the snap rings and check to see that it is securely assembled.



- Install the piston ring in the piston using piston ring pliers.



- Identify the mark "Y" or "TOP" on the ring end to prevent the top and bottom of the piston ring from being interchanged and make the marked portion face upward.

(The surface marked as "Y" is upper surface.)

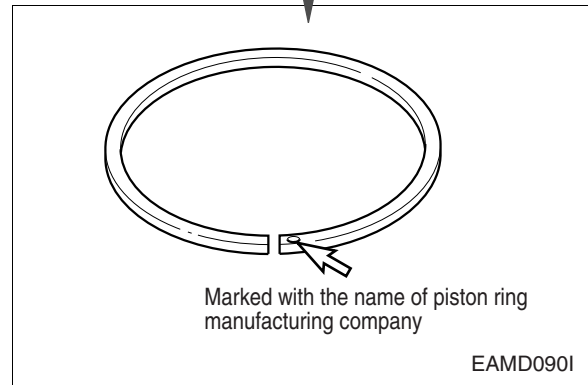
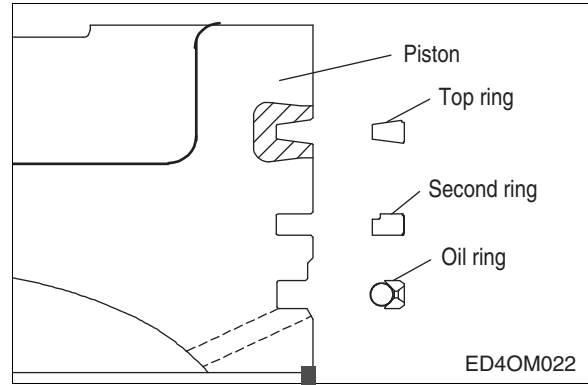

- Adjust the angle among individual piston ring gaps to 90° and fit a piston assembling jig onto the piston, Use care not to match the ring gaps with the pin direction.



- Install the bearing by aligning it with the connecting rod key groove and apply oil to the bearing and piston.

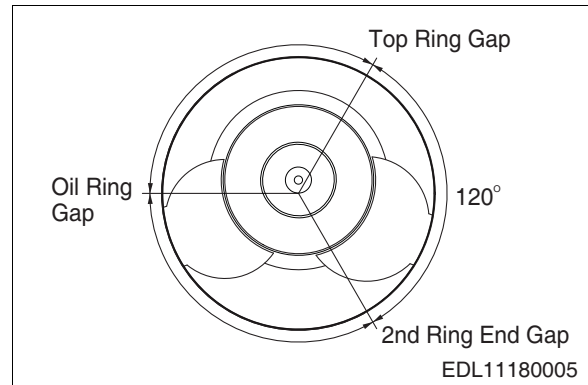

- Position the valve seating surface toward the tappet hole and insert the piston with hand.



**CAUTION:**

**Use care not to damage the cylinder liner and piston, and slightly lift and insert the piston into the cylinder so that the ring may not be damaged by the fillet of the liner.**

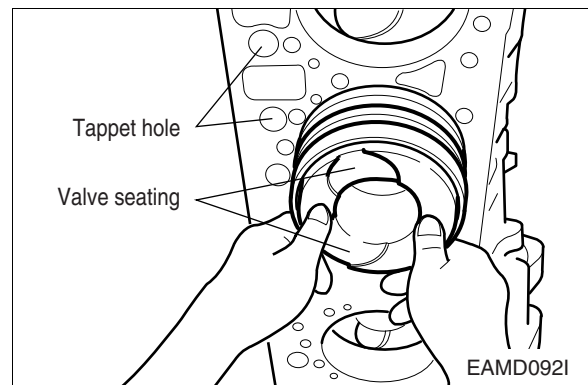



- Install the bearing in the connecting rod cap and apply oil.



**CAUTION:**

**Make sure that the manufacture serial numbers impressed on the connecting rod cap and connecting rod big end are identical, and install the connecting rod cap by aligning it with dowel pin.**

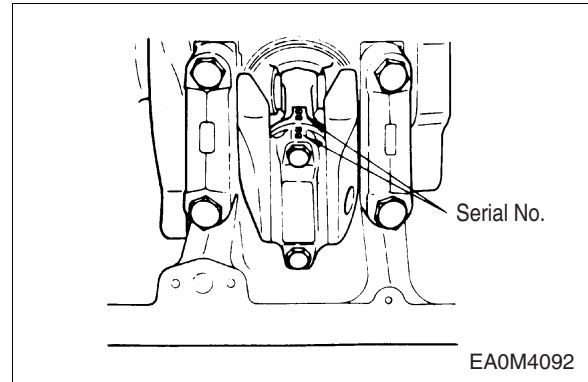

- Semi-tighten the fixing bolts with hand, tighten them to the specified torque using a torque wrench as follow.

**<Connecting rod tightening torque>**

Tightening torque	1st Step	4 ±0.2 kgf·m
	2nd Step	60° ±3°

Note) Do not apply oil to the joint before bolting.



**CAUTION:**

**Connecting rod bearing bolts can only be reused up to 3 times; reusing them more than that may cause damage.**



- When the connecting rod bearing cap bolts are tightened, check the connecting rod end play to the right and left with hand.
- If no end play is found, remove and re-install or replace the connecting rod bearing cap.

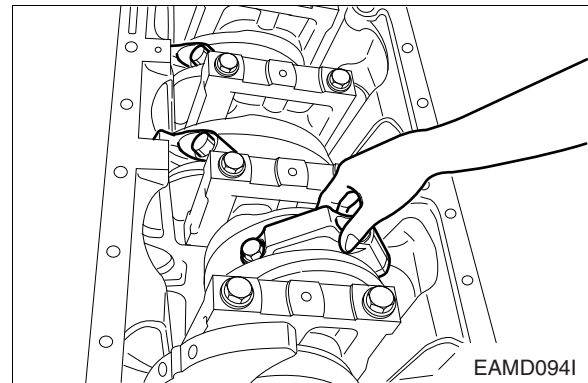

### 3.3.12. Timing gear case



- Mount a new gasket using dowel pin on the cylinder block.
- Put the time gear case to the cylinder block by aligning the dowel pin hole of timing gear case with its pin, and then assemble it by tapping lightly with an urethane hammer to the right and left (Particularly around dowel pin).
- Tighten the bolts for assembling to the specified torque. However, in case of tightening the bolts, tighten primarily the bolts of both end parts and then do the rest.

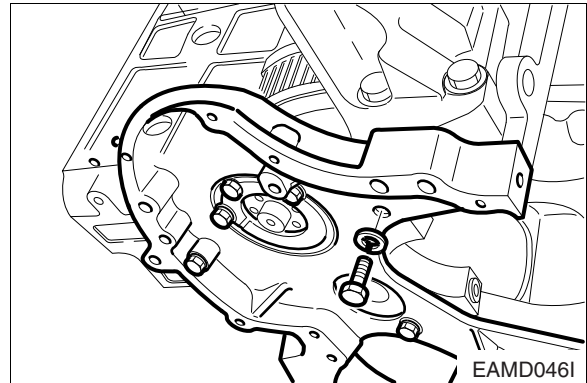

### 3.3.13. Timing gear and idle gear pin



- Install the oil pump idle gear onto the No.7 bearing cap.
- Install a thrust washer over the camshaft and assemble the cam gear by aligning it with camshaft dowel pin. Tighten the cam gear assembling bolts to the specified torque. (Zigzag method)

Torque	2.2 kg.m
--------	----------

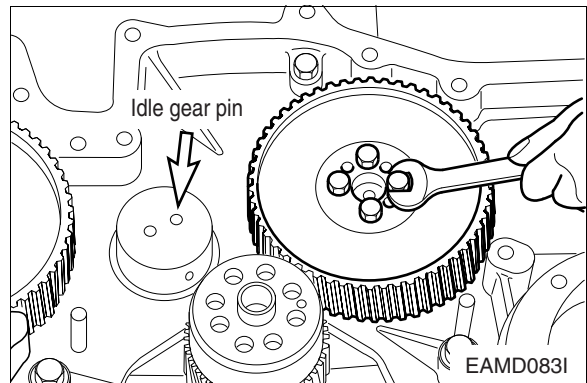

- With the oil port on the idle gear pin facing the cylinder block, install the idle gear pin.



- Idler gear pin with oil hole is assembled toward cylinder block.

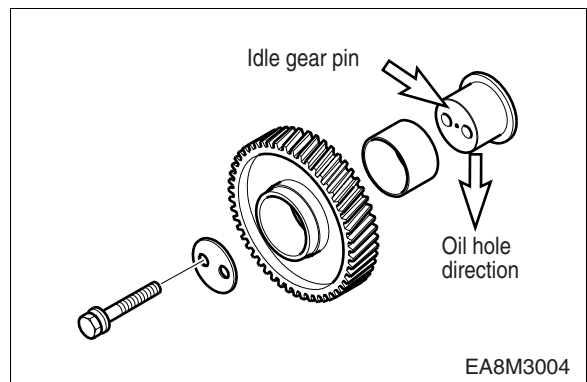



- Install the idle gear by coinciding the marks impressed on the crank gear, cam gear, ignition timing drive gear, and idle gear.



- Install a thrust washer on the idle gear and tighten to specified torque.

Torque	3.1 kg.m
--------	----------



- Check and adjust the amount of backlash between gears using a feeler gauge.

Measuring position (between)	Backlash	Limit
Cam gear & idle gear	0.16 ~ 0.28 mm	0.35 mm
Crank gear & idle gear	0.16 ~ 0.28 mm	0.35 mm
Ignition timing gear & drive gear	0.16 ~ 0.28 mm	0.35 mm

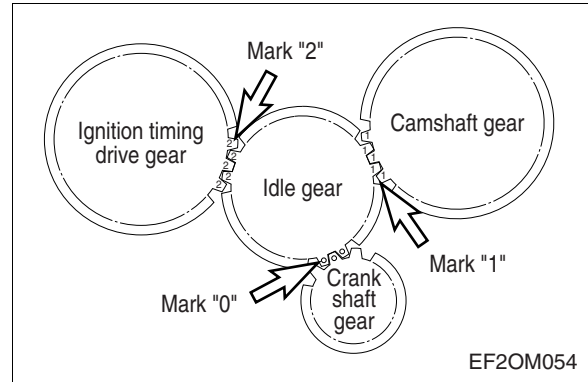

### 3.3.14. Oil pump and oil pipe



- Install a dowel pin in the No.7 bearing cap, then assemble the oil pump by tapping lightly with urethane hammer.
- Tighten the assembling bolts with specified torque.

Torque	4.4 ±1.1 kg.m
--------	---------------

- Assemble the oil suction pipe with the delivery pipe to oil pump by the bolts.

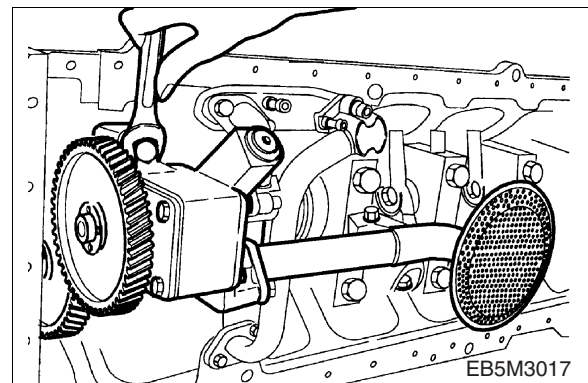

### 3.3.15. Water pump

- Mount a new gasket.
- Install the water pump on the cylinder block and tighten the assembling bolts with specified torque.



Torque	2.2 ±0.55 kg.m
--------	----------------

- Connect water pipes and by-pass pipe to the water pump.
- Connect a water pipe to the expansion tank.

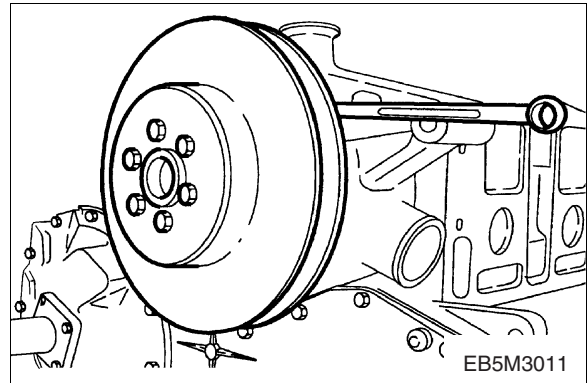

### 3.3.16. Oil seal (front side)

- Apply lubricating oil to the outside of the oil seal and the oil seal hole of the timing gear case cover.
- Put the new oil seal on the oil seal hole of timing gear case cover aligning the center of them, then assemble the oil seal using an oil seal fitting jig.

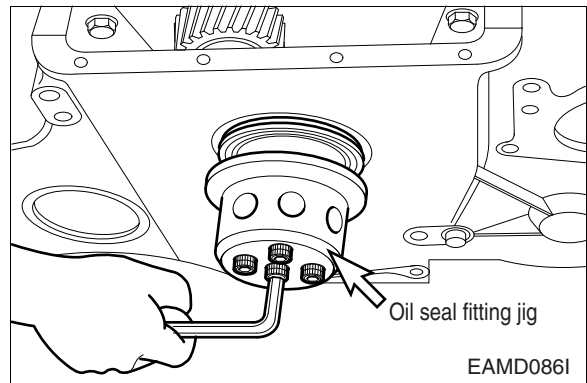

### 3.3.17. Timing gear case cover

- Install dowel pin on the timing gear case.
- Mount a gasket by aligning the fixing bolt holes with those on the gasket.
- Align the dowel pin with the cover pin hole, then install the cover with light tap.
- Tighten the fixing bolts beginning with the oil pan fitting face.
- In the assembling, be careful not to be damaged by the crankshaft.

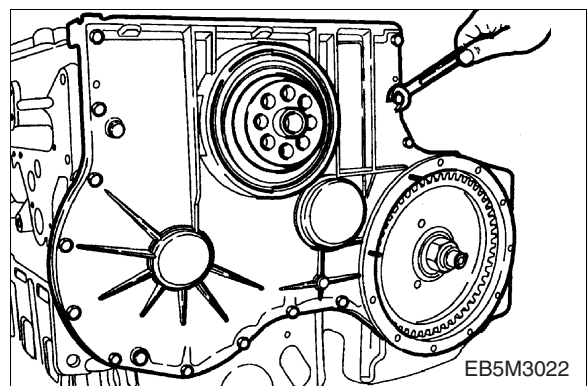

### 3.3.18. Vibration damper



- Insert the vibration damper to the crankshaft, and assemble by tightening the assembling bolts at the specified tightening torque according to bolt tightening order. (refer to right figure.)

Torque	13.4 ±1.3 kg.m
--------	----------------

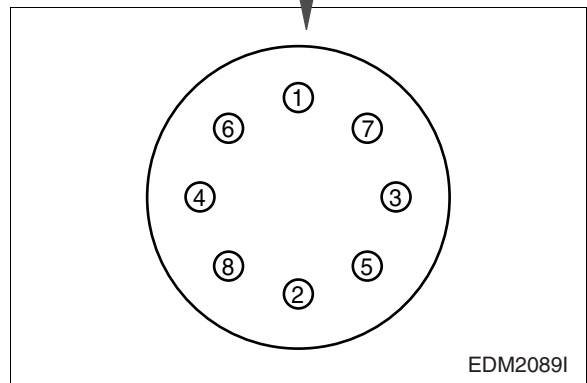
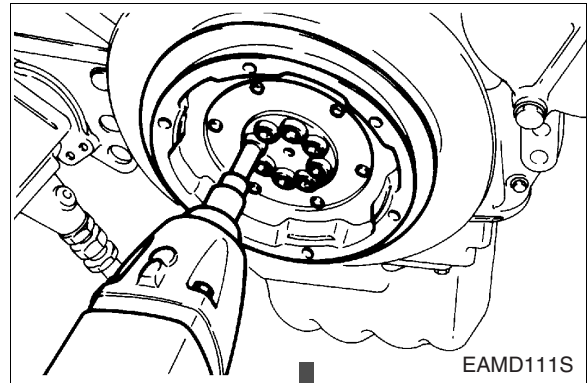

### 3.3.19. Oil pan



- Remove the gaskets thoroughly that project at the timing gear case, case cover of cylinder block, and the contacting part of flywheel housing by means of a scraper.



**CAUTION:**  
Be careful for the gasket pieces not fall into the engine during the work.

- Coat the silicone at the gasket part that was removed (Contacting part), and attach the new oil pan gasket.



- Assemble the oil pan by tightening the oil pan assembling bolts, and when tightening bolts, primarily tighten the bolts (4ea) at the both ends, and then tighten the rest bolts to specified torque.

Torque	2.2 ±0.22 kg.m
--------	----------------

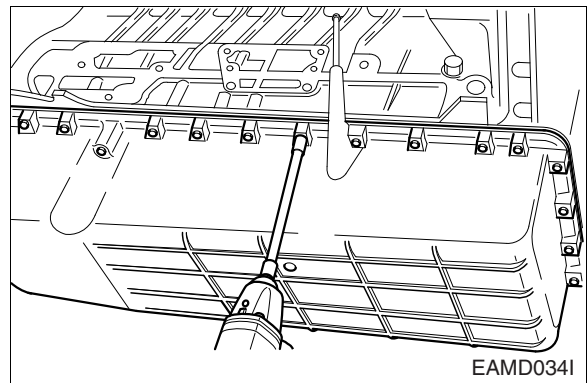



- Align the bolt holes with gasket holes to prevent damage to the gasket and tighten.

### 3.3.20. Oil filter & oil cooler

- Install the gasket on the cylinder block.
- Assemble the oil cooler by tightening the assembling bolts.

Torque	6.2 ±1.55 kg.m
--------	----------------

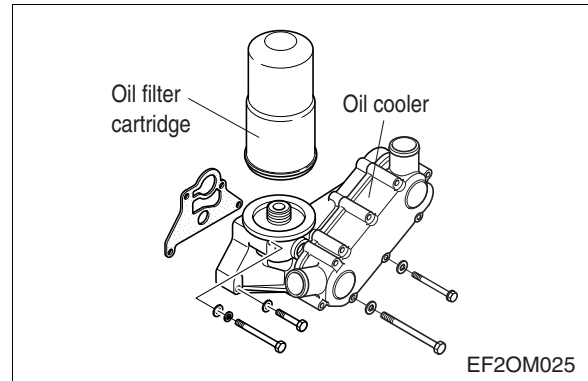

- Apply engine oil to the oil filter cartridge o-ring and assemble the cartridge using a filter wrench.
- Connect the cooling water pipe with the cooling water pump and tighten a hose clamp.

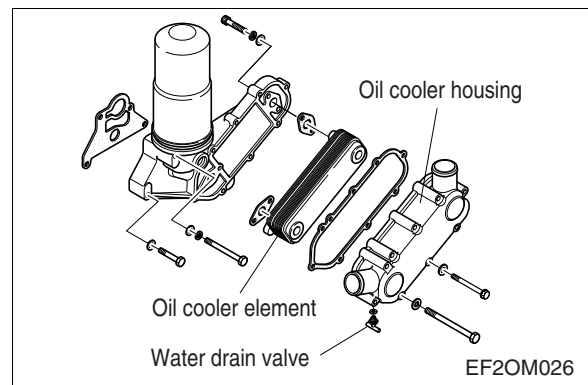

### 3.3.21. Starting motor

- Assemble the starter in position on the flywheel housing.

Torque	11.2 ±2.8 kg.m
--------	----------------

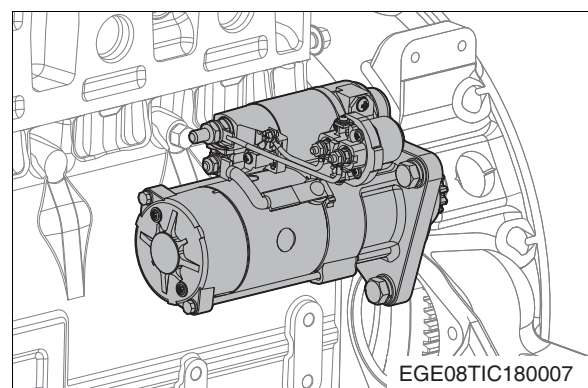

### 3.3.22. Intake and exhaust valves



- Identify the marks of "GI" and "GE" impressed on the valve head before assembling the valve with the valve head.



- With a valve stem seal fitting jig, assemble the valve stem seal on the valve guide.

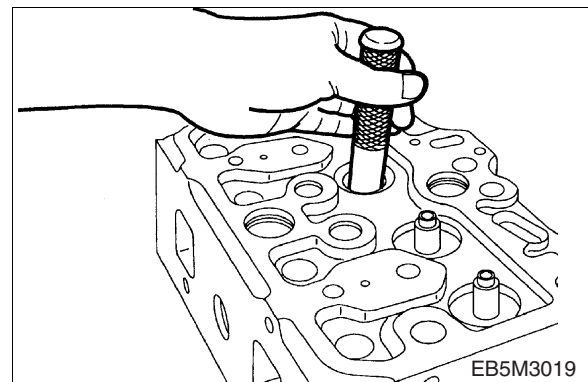
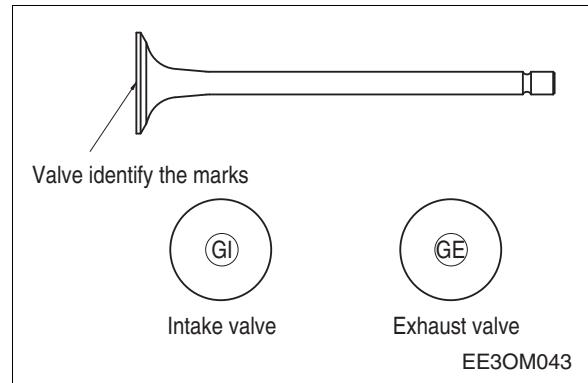

- After installing valve springs and spring retainer, press the retainer with a jig, then install the cotter pin.



- Tap the valve stem lightly with a rubber hammer to check that the valve is assembled correctly.

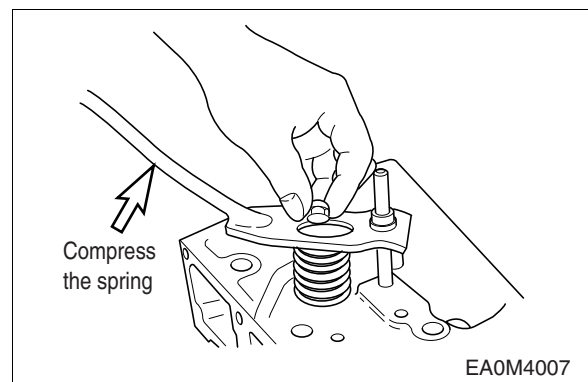

### 3.3.23. Cylinder head

- Blow the bolt holes of cylinder block with a compressed air and remove the foreign matter.



- Clean the head gasket contact surface thoroughly.



- However, be careful for the foreign material not to enter into the combustion chamber.



- Assemble the new head gasket by aligning the holes with dowel pins of cylinder block with "TOP" mark facing upward.

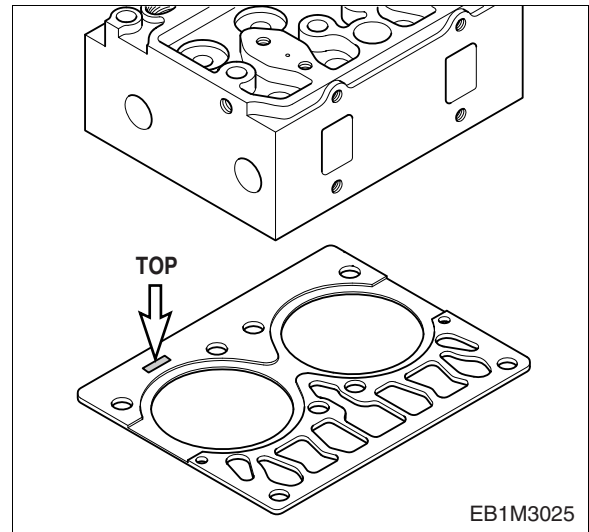

- Check the inside of combustion chamber for foreign substances, and carefully mount the cylinder head assembly in the block by aligning the dowel pin with the dowel pin hole.



- Be careful not to damage the cylinder head gasket. If the dowel pin is not in alignment, lift the cylinder head again and then remount it.

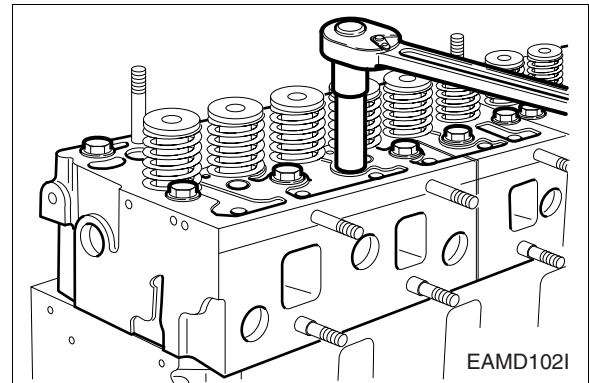

#### CAUTION:

**After tightening the cylinder head bolts, even at disassembling, the cylinder head gasket should be changed a new one.**



- Tighten in proper sequence to the specified torque according to bolt tightening order. (right figure)

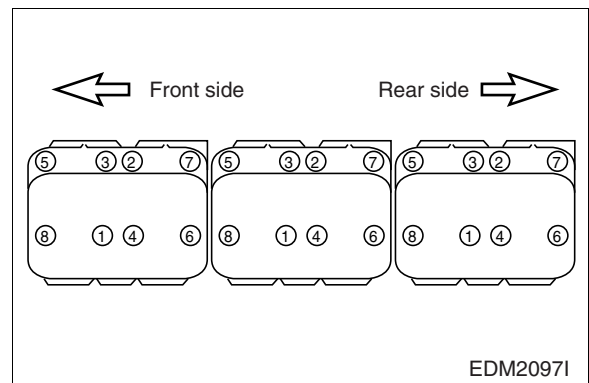

### <Cylinder Head Bolts>

Specification	 M14 x 1.5
Torque	1st : 6 ±0.6 kg.m 2nd : 90° ±9° 3rd : 90° ±9° 4th : 90° ±9° Final : 60° ±6° (Angle method)

- However, before tightening bolts, the side parallel degree between cylinder heads should be adjusted.

### <Tightening order of bolts by steps>



- (1) First stage : Tighten 1 ~ 2 threads with hands.
- (2) Second stage : Tighten at about 6 ±0.6 kg.m with a wrench.
- (3) Third stage : Tighten at rotating angle method 90° ±9° with a wrench.
- (4) Fourth stage : Tighten at rotating angle method 90° ±9° with a wrench.
- (5) Fifth stage : Tighten at rotating angle method 90° ±9° with a wrench.
- (6) Sixth Stage : Finally tighten at rotating angle method 60° ±6° with a torque wrench.



- However, all bolts are tightened simultaneously by above steps.
- Coat the push rod with engine oil and insert it into the push rod hole.



### CAUTION:

Do not reuse the cylinder head bolts when assembling the cylinder head.

### 3.3.24. Rocker arm assembly



- Apply lubricating oil to the rocker arm bush and shaft, and assemble the intermediate bracket with the rocker arm (rocker arm assembly) on the cylinder block using fixing bolts. In tightening the bolts, it must be done at the specified value using zigzag method.



Torque	M10 x 1.5	4.4 ±0.44 kg.m
	M12 x 1.5	8.0 ±0.8 kg.m

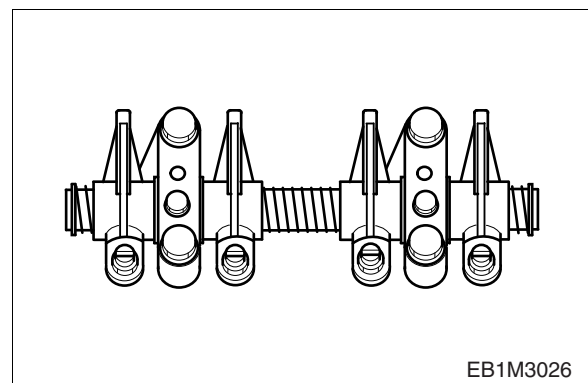

- Semi-install valve clearance adjusting bolts onto the rocker arm.
- Install the spring, rocker arm, bracket, rocker arm, spring, washer, and snap ring in the described sequence.
- Install the rocker arm and bracket in the same direction.

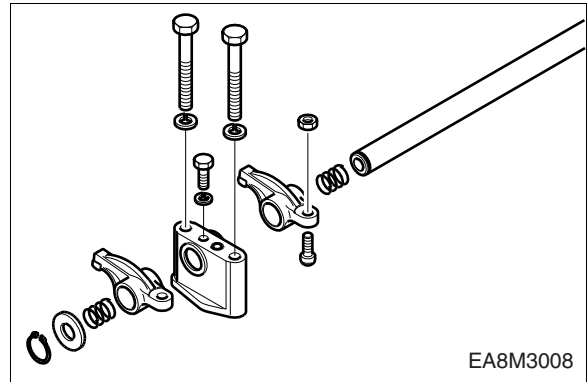

### 3.3.25. Ignition coil and spark plug



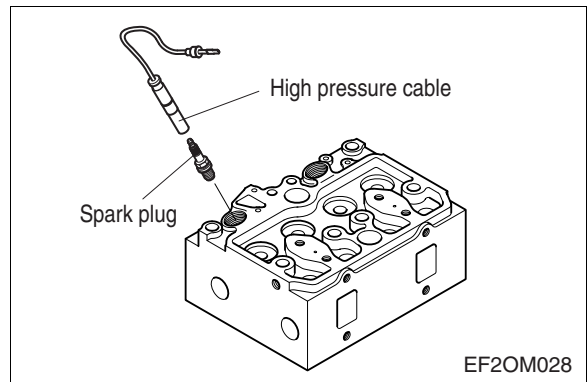

- Tighten the spark plug at cylinder head with socket tool.
- Assemble the high pressure cable on the spark plug and ignition coil.

Socket tool	Hex. head 16 mm (5/8 inch)
Spark plug torque	2.5 ~ 3.0 kg.m



### 3.3.26. Adjust the valve clearance as following guide.



- By turning the crankshaft, when overlap the intake and exhaust of #6 cylinder, that is, when #1 cylinder's piston come at the compression top dead center (OT), adjust the valve clearances by  mark indicated.
- After having turned the crankshaft by 360° and overlap the intake & exhaust valves of #1 cylinder, that is, when #6 cylinder is in the state of compression TDC (OT), adjust the valve clearances by  mark indicated.

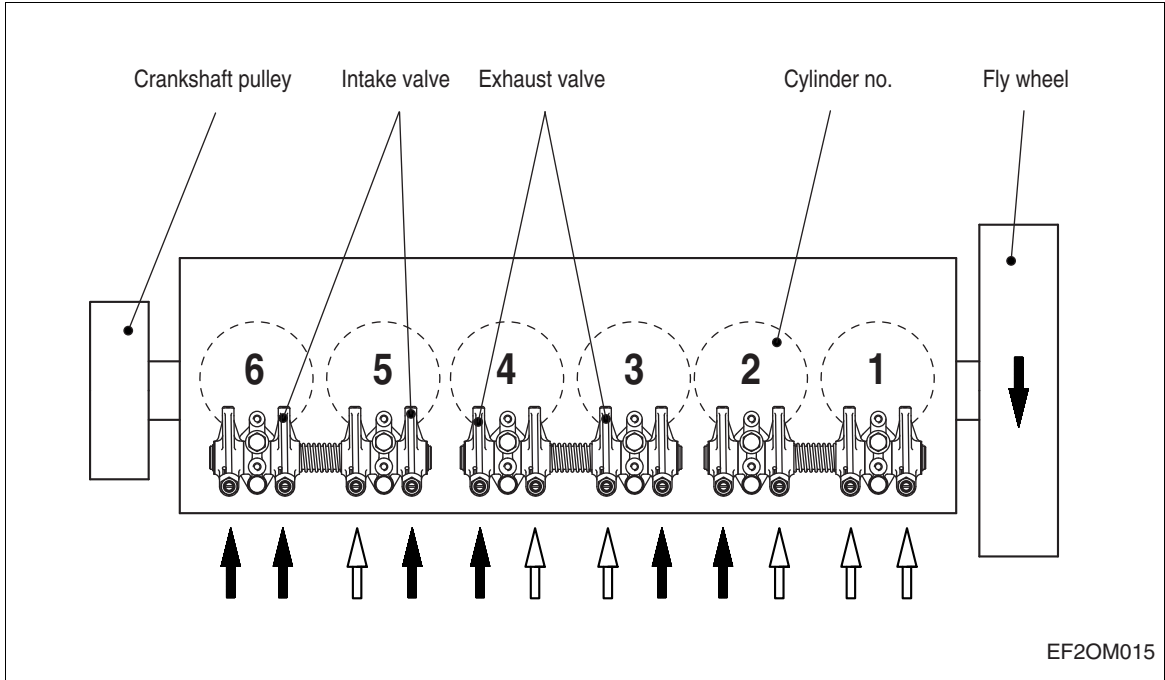

- To adjust the clearance, loosen the lock nuts of rocker arm adjusting screws and push the feeler gauge of specified value between a rocker arm and a valve stem (to measure the clearance of the valve and rocker arm contacting part) and adjust the clearance with adjusting screw respectively and then tighten with the lock nut.



- As for the valve clearance, adjust it when in cold.

Specified Value		Measurement Tolerance	
Intake Valve	Exhaust Valve	Intake Valve	Exhaust Valve
0.4 mm	0.4 mm	±0.05 mm	



#### CAUTION :

- (1) Crankshaft revolution is done by hands without using a starting motor.
- (2) Turn it to the direction of engine rotation, but do not use the installing bolts at the turn.
- (3) The cylinder no. and the order of intake and exhaust can be determined from the flywheel housing side.



- Adjust valve clearance with a feeler gauge and tighten the fixing nuts to specified torque.

Torque	4.4 ±0.45 kg.m
--------	----------------

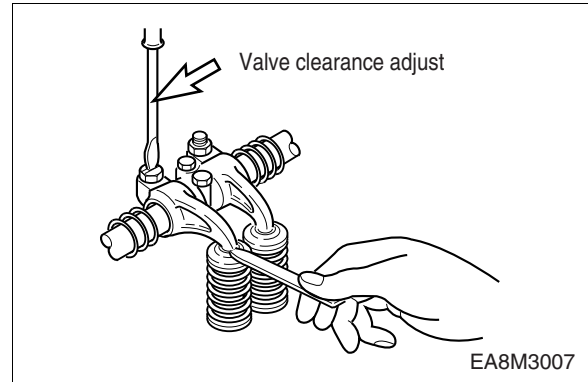

### 3.3.27. Ignition timing drive gear



- Mount gasket by aligning the bolt holes with pin holes on the timing drive gear housing.
- After tighten the fixing bolts in the direction of the coupling.

Trigger wheel run-out	Bellow 0.2 mm
-----------------------	---------------

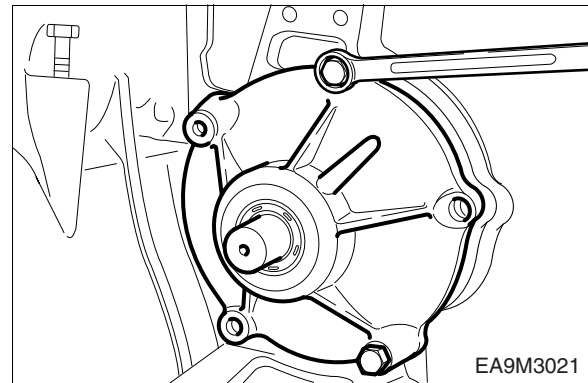

### 3.3.28. Ignition timing adjustment



- Ignition timing sensor and trigger wheel location is affected the engine starting that refer to bellow the described order.

● **Check ignition timing angle**

- 1) Turning the crankshaft, let the valves of #6 cylinder's valves overlap.
- 2) Check notch mark of the right figure corresponding to the ignition timing aligner with the pointer ( ↓ ) on the flywheel housing.



Model	GE08TIC
Ignition timing (B.T.D.C static)	13°

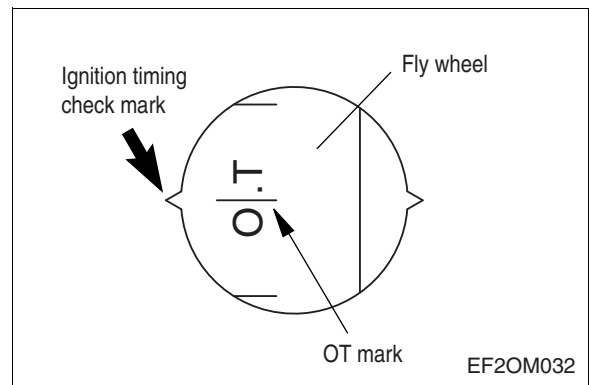
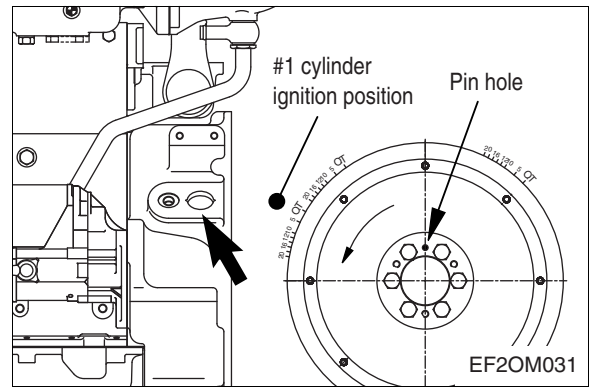

● **Adjust ignition timing angle**

- 1) Loosen the trigger wheel lock bolts, and align the sensor on the trigger wheel at starting position of the undivided holes (as bellow figure) and then tighten the trigger wheel lock bolts.



Trigger wheel lock bolt torque	2.0 kg.m
--------------------------------	----------

Timing sensor gap	1.0 mm ±0.1 mm
-------------------	----------------

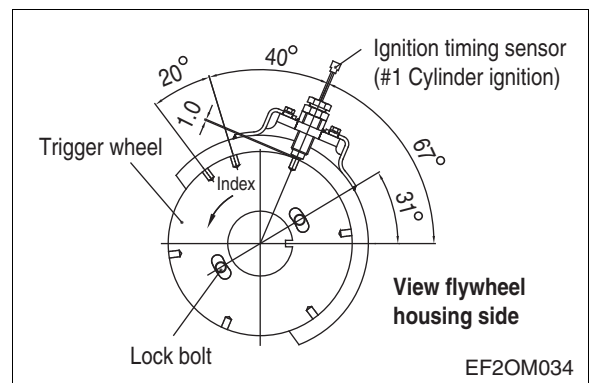
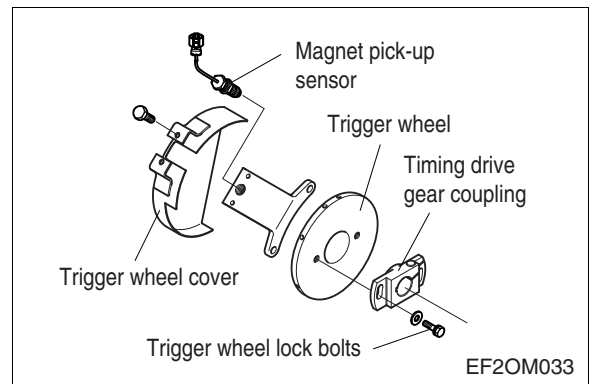

● **Adjust ignition timing sensor gap**

- 1) Move the lock nut to hexagonal side of sensor completely.
- 2) Rotate (Clockwise) the timing sensor on the coupling housing, until the end of it reach on the timing drive gear.
- 3) Then rotate (Counter clockwise) the timing sensor for 240° (gap 1.0 mm) and fix lock nut.
- 4) Tolerance limit is 24°. (gap  $\pm 0.1$  mm)

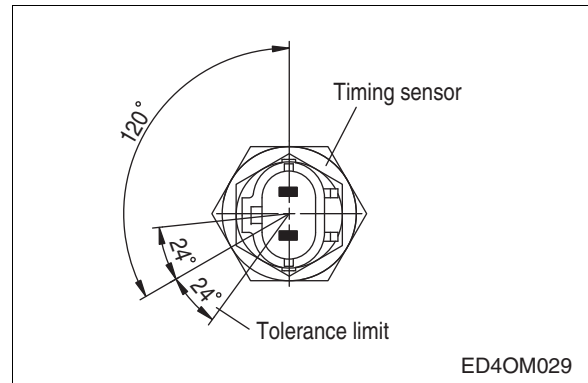

● **Assemble the ignition timing sensor to timing gear housing.**

Trigger wheel lock bolt torque	2.0 kg.m
Timing sensor gap	1.0 mm $\pm 0.1$ mm

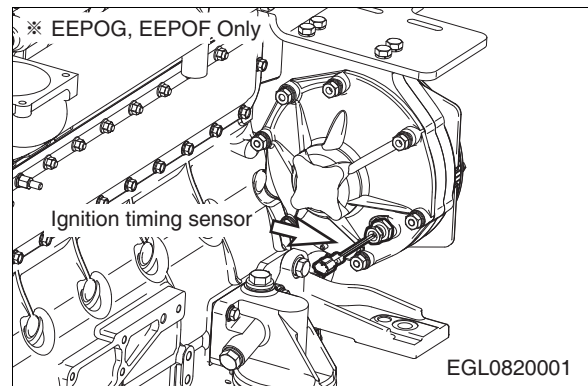

**3.3.29. Intake manifold**



- Put in the new gasket between the cylinder head and manifold, and assemble the intake manifold by tightening the assembling bolts.

Torque	4.4 $\pm 0.44$ kg.m
--------	---------------------

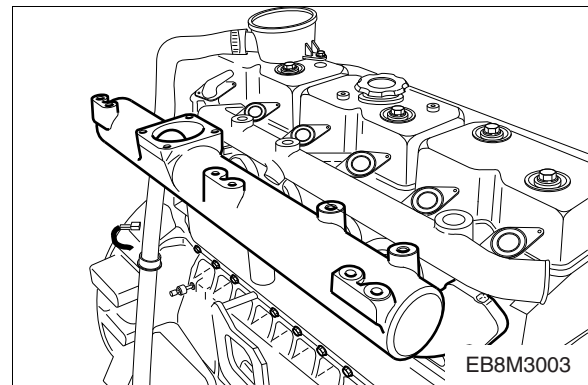

**3.3.30. Exhaust manifold**



- Assemble the exhaust manifold with steel gasket in order to be installed and be sure to check the squared port of the gasket whether square port of the cylinder head is aligned before assembling.



- Tighten the fixing bolts with specified torque.

Torque	M10 x 1.5	4.4 $\pm 0.44$ kg.m
	M12 x 1.5	8.0 $\pm 0.8$ kg.m

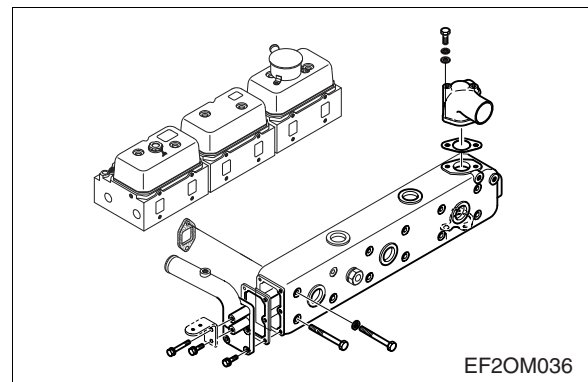



**CAUTION :**

**Be careful to assemble the exhaust manifold. it is very heavy.**

**3.3.31. Turbocharger**



- Fit a new gasket over the stud bolts of the exhaust manifold before tightening those turbocharger fixing nuts.

Torque	4.4 kg.m
--------	----------

- Install the oil supply pipe and return pipe.
- Tighten the clamps of rubber hose that is connected air pipe to the intercooler.
- Assemble the cooling water inlet & outlet pipe on the turbocharger.

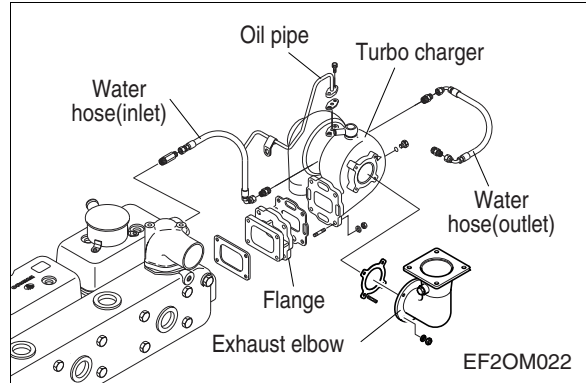

**3.3.32. Intercooler & throttle valve**



- Install the intercooler on the bracket of flywheel housing and tightening the fixing bolt on it.
- Assemble the throttle valve & air pipe on the intake manifold.



**CAUTION:**

**Check assembled after the all engine parts install and tighten fuel line.**

**Open fuel line valve and check for leaks using soapy water or commercial leak detector.**

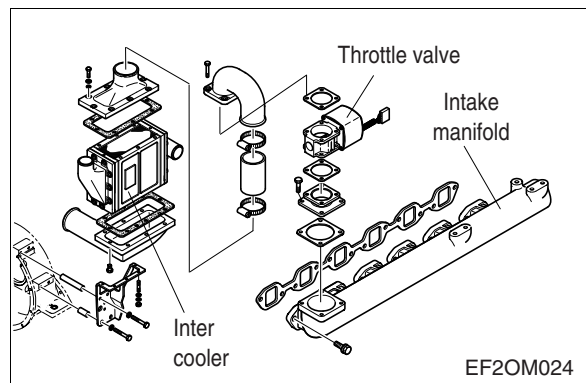
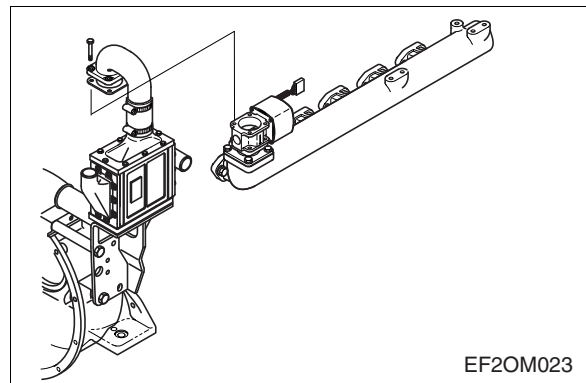

### 3.3.33. Fuel mixer & gas pressure regulator

- Assemble the fuel mixer and air pipe from the turbocharger.
- Tighten the gas pressure regulator and nature gas pipe from the fuel mixer.



#### CAUTION:

**Check assembled after the all engine parts install and tighten fuel line.**

**Open fuel line valve and check for leaks using soapy water or commercial leak detector.**

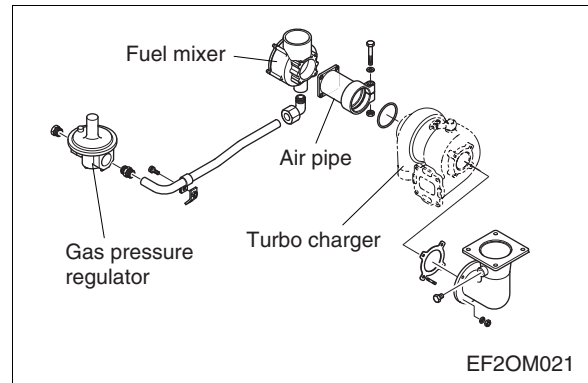

### 3.3.34. Ignition control module : ICM

- Mount the ignition control module (ICM) bracket on the cylinder block.
- Assemble the fixing bolts with the ignition control module.

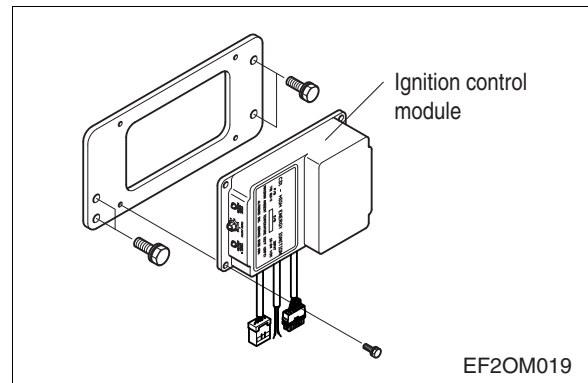

### 3.3.35. Ignition coil & high voltage cable

- Install the bracket on the intake manifold and assemble the ignition coils
- Assemble the high voltage cables by hand from each cylinder head.

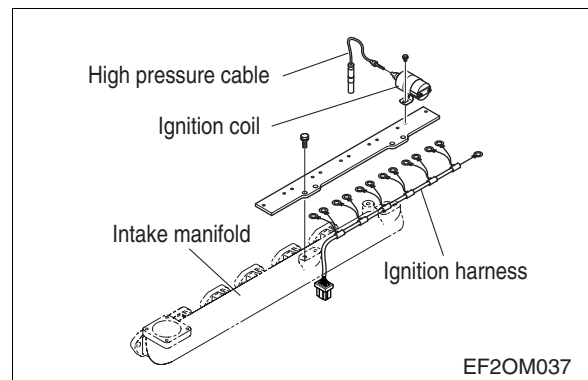

### 3.3.36. Cooling water pipe

- Attach a new gasket on the cylinder head.
- Install the cooling water pipe and tightening the fixing bolt on it.

Torque	2.2 ±0.22 kg.m
--------	----------------

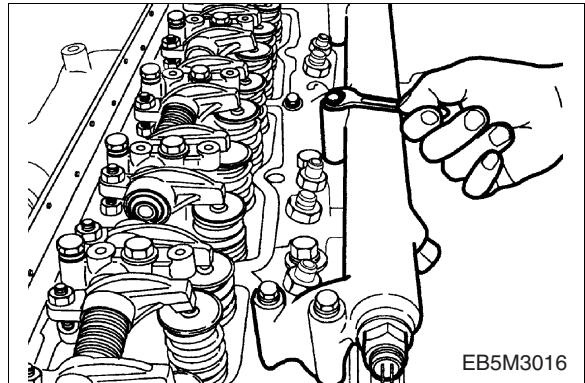

### 3.3.37. Alternator

- Install the alternator mounting bracket and supporter to the cylinder block, then tighten the fixing bolts.
- Install the alternator with fixing bolts to the mounting bracket.

Torque	8.0 kg.m
--------	----------

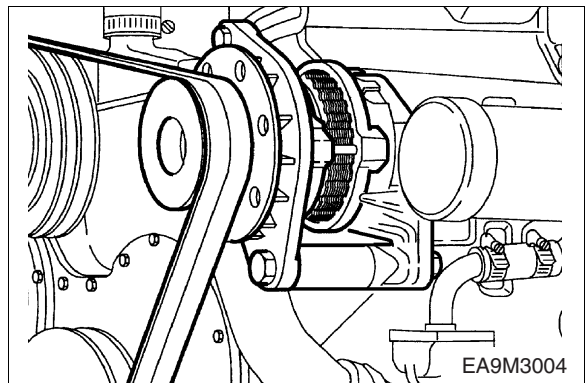

### 3.3.38. Cylinder head cover



- Attach a new gasket on the cylinder head cover.
- Assemble the cylinder head cover to the cylinder head by tightening the cap bolts for fixing the cylinder head cover.

Torque	3.1 ±0.3 kg.m
--------	---------------

- Assemble the breather and breather hose.
- Fit the oil filler cap on the cylinder head cover.

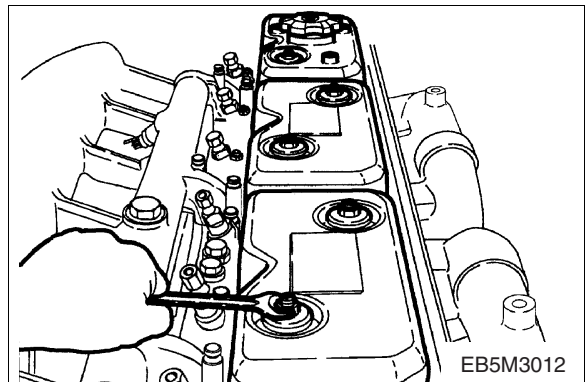

### 3.3.39. V-Belt

- Install the V-belt on the crank pulley, alternator pulley and water pump pulley.
- Adjust the V-belt tension using the tension adjusting support.

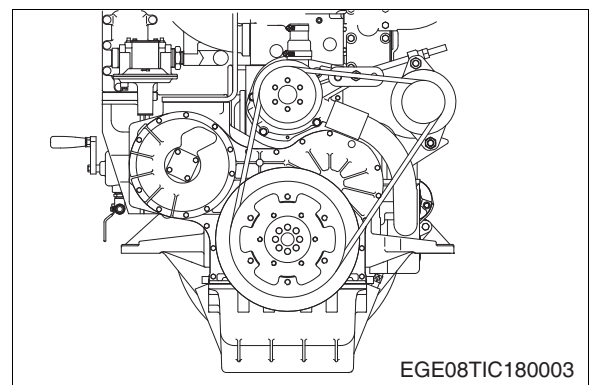
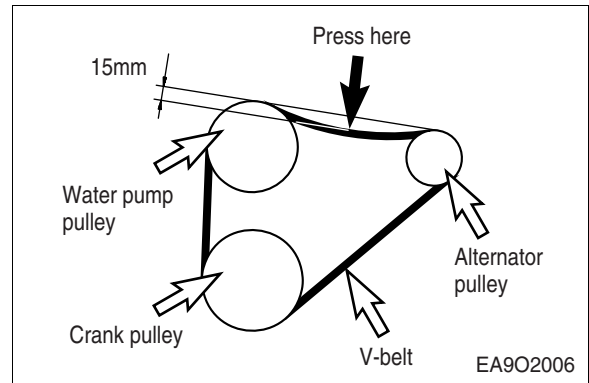

### 3.3.40. Oil level gauge

- Apply sealant (Loctite #262) to the bottom side of the guide tube.
- Then assemble the guide tube and

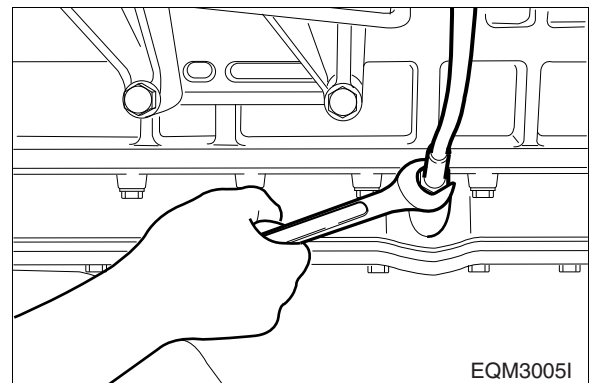

### 3.3.41. Engine speed controller : ESC

- Install engine speed controller (ESC), connect the harness and various sensors.

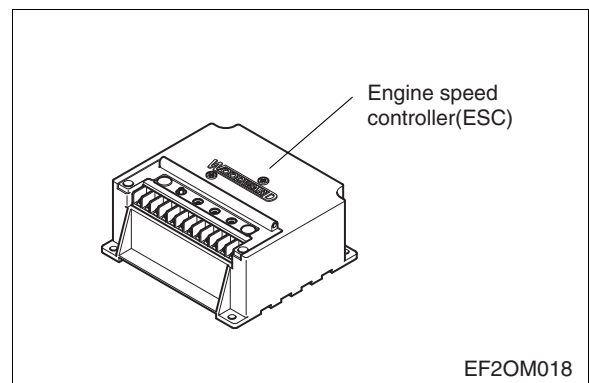

### 3.4. Electrical system

#### 3.4.1. Electrical component of engine

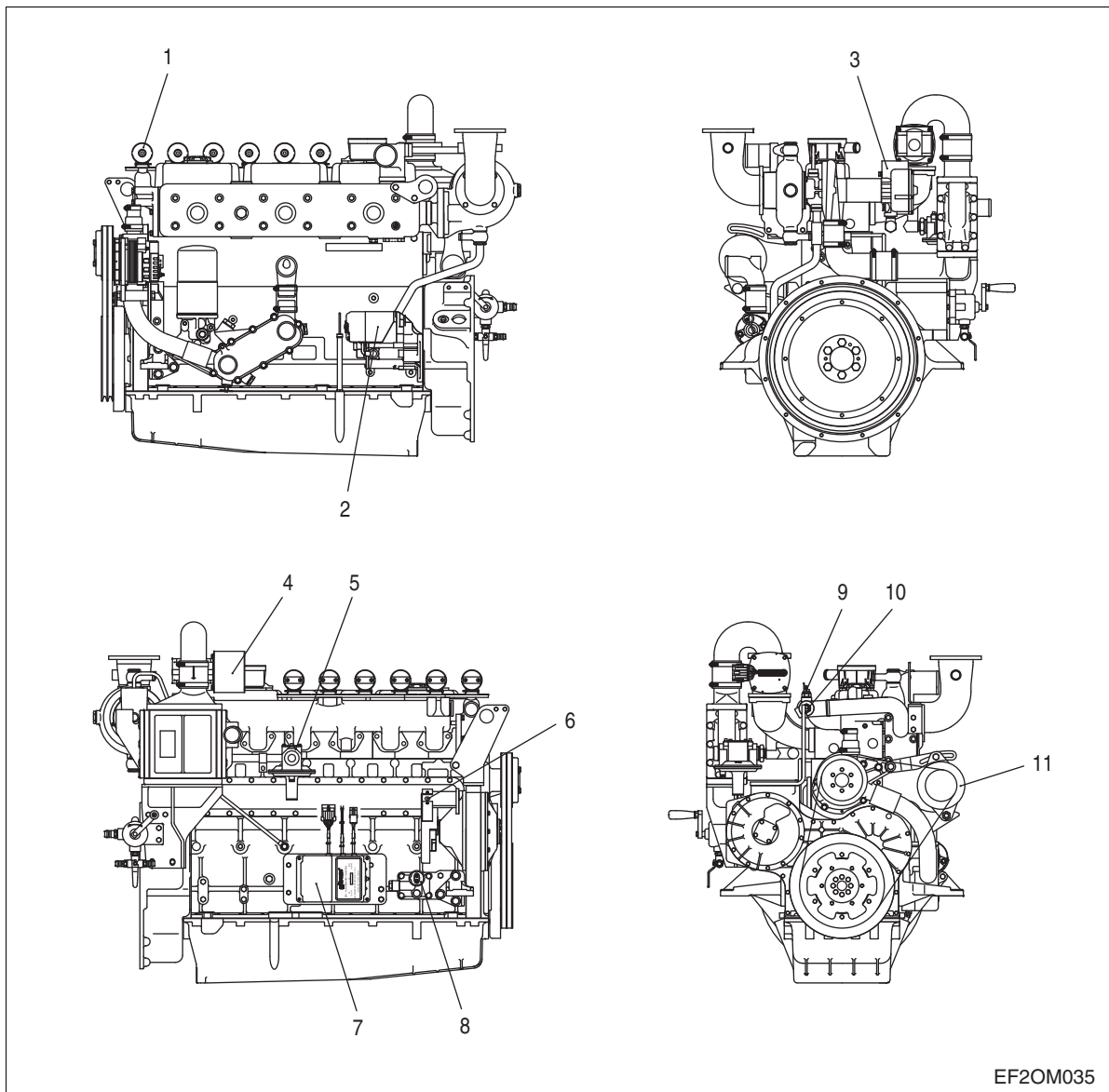

EF2OM035

- |                           |                                      |
|---------------------------|--------------------------------------|
| 1. Ignition coil          | 7. Ignition control module (ICM)     |
| 2. Starter                | 8. Oil pressure unit                 |
| 3. Nature gas air mixer   | 9. Cooling water temperature switch  |
| 4. Throttle valve         | 10. Cooling water temperature sensor |
| 5. Gas pressure regulator | 11. Alternator                       |
| 6. Ignition timing sensor |                                      |

### 3.4.2. Engine control system

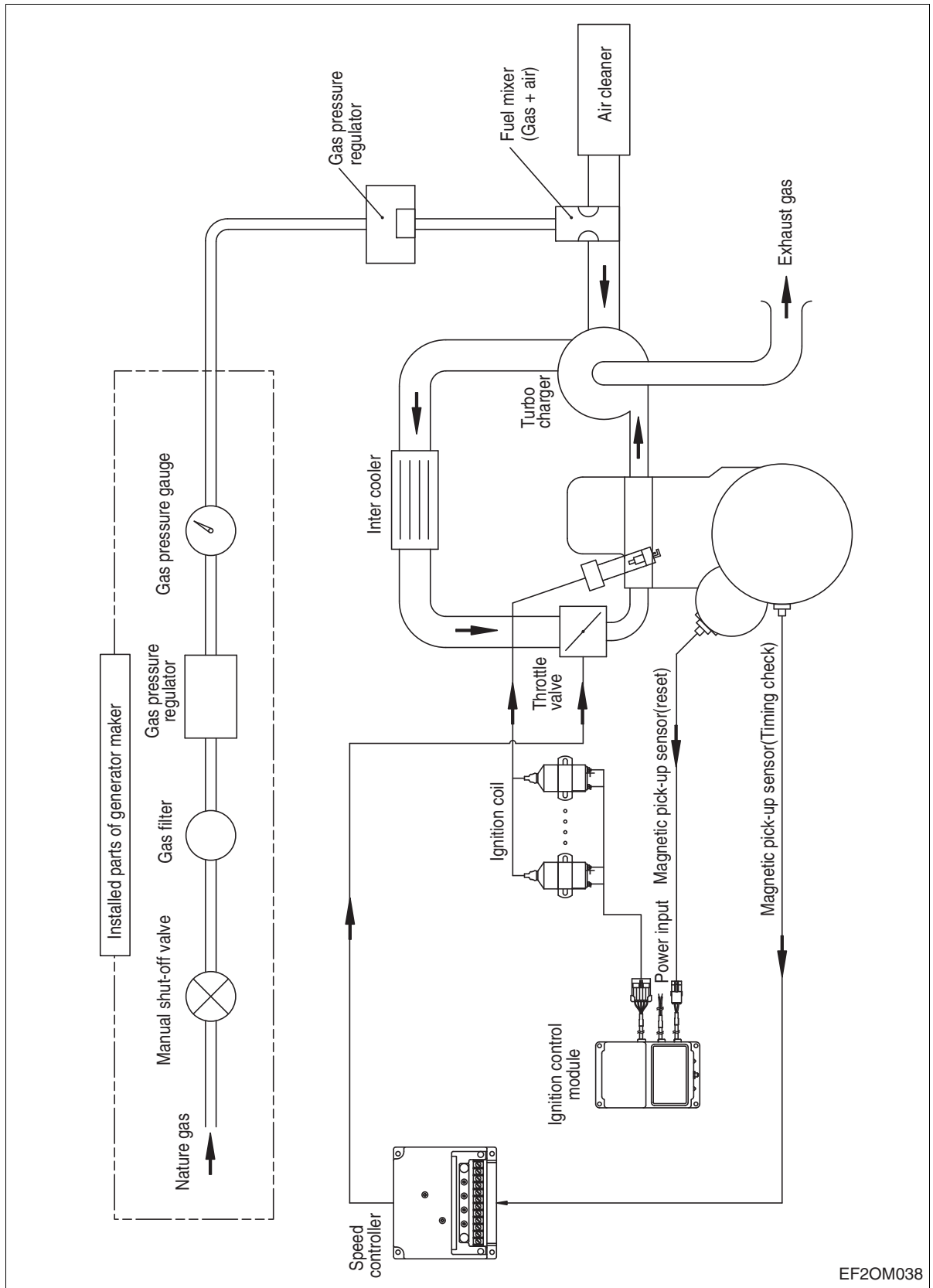

EF2OM038

### 3.4.3. Engine control harness

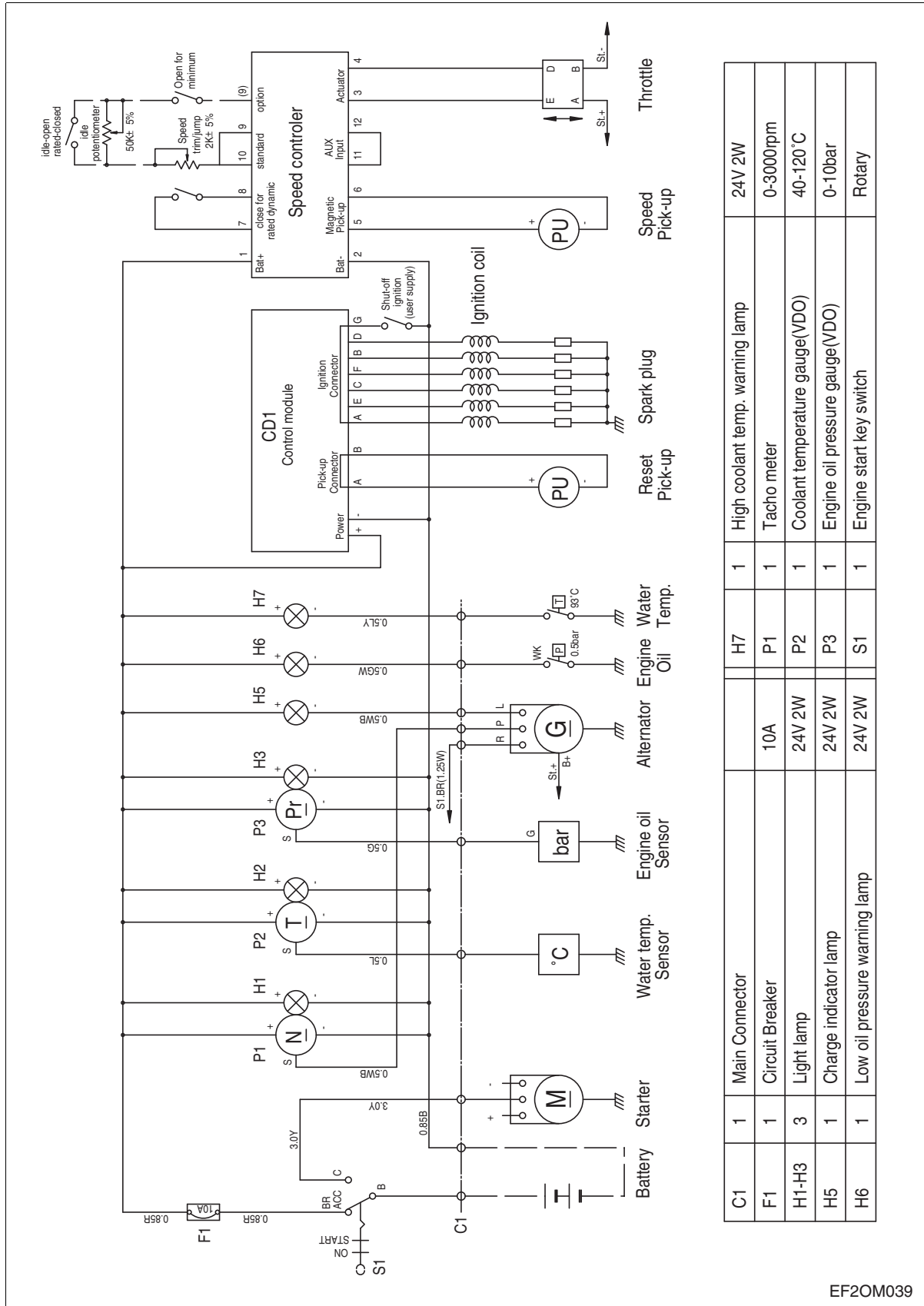

EF2OM039

### 3.5. Speed controller

#### 3.5.1. Speed controller description

- The speed controller is designed to provide basic isochronous speed control for gas engines.
- Engines with mechanical loads and generator loads are handled equally well.

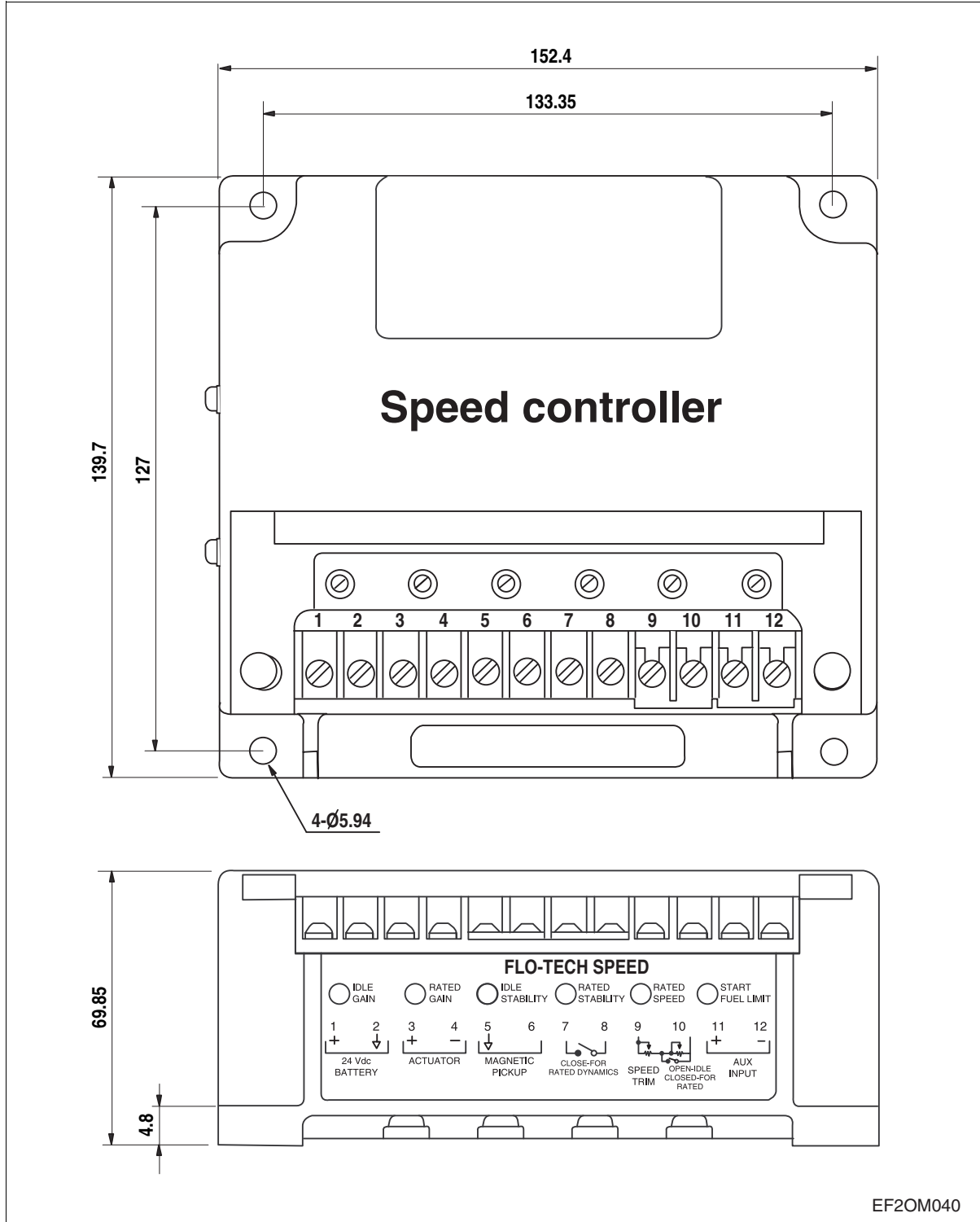

### 3.5.2. Speed controller circuit

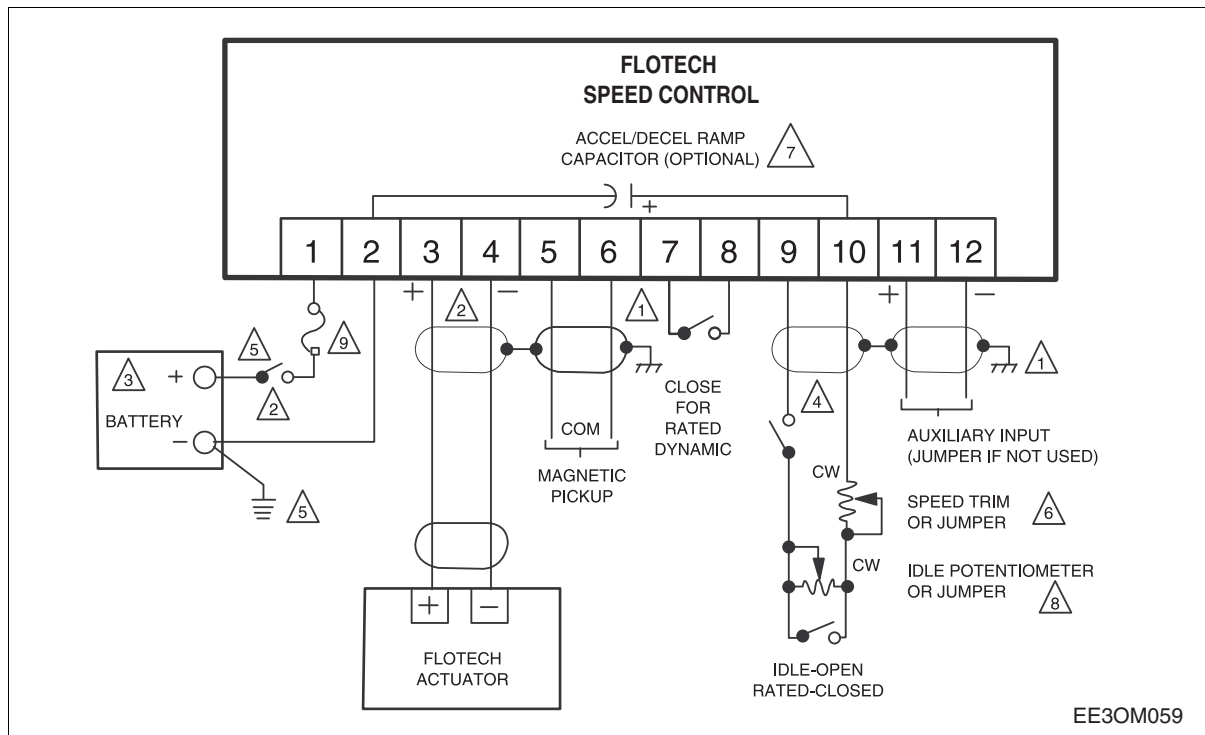

- **1** Shield wires to be twisted pairs with shield grounded at one end only.
- **2** No. 18AWG or 20AWG standard wire. Must be as short as possible. 50ft. maximum wire length for 20AWG wire. 80ft. maximum wire length for 18AWG wire.
- **3** Use 24 volt system.
- **4** Open for minimum fuel.
- **5** For positive ground systems, switch and fuse to be located in series with battery (-) and terminal 2. Positive terminal becomes chassis ground. Leads from battery to terminals 1 & 2 must be direct and not pass through distribution points.
- **6** Approximate speed change with trim potentiometer
  - ◆  $\pm 2.5\%$  using a  $1K\ \Omega$  potentiometer
  - ◆  $\pm 5\%$  using a  $2K\ \Omega$  potentiometer
- **7** About one second ramp time per  $50\ \mu F$ . Capacitor specifications :  $200\ \mu F$  maximum,  $15WVdc$  minimum.  $15WVdc$  maximum. Less than  $30\ \mu A$  DC leakage current over temperature range.
- **8** Idle range about 25% to 100% rated using 50K potentiometer.
- **9** Use a 1 amp fuse(3 AWG)

### 3.6. Ignition controller

#### 3.6.1. Ignition controller circuit

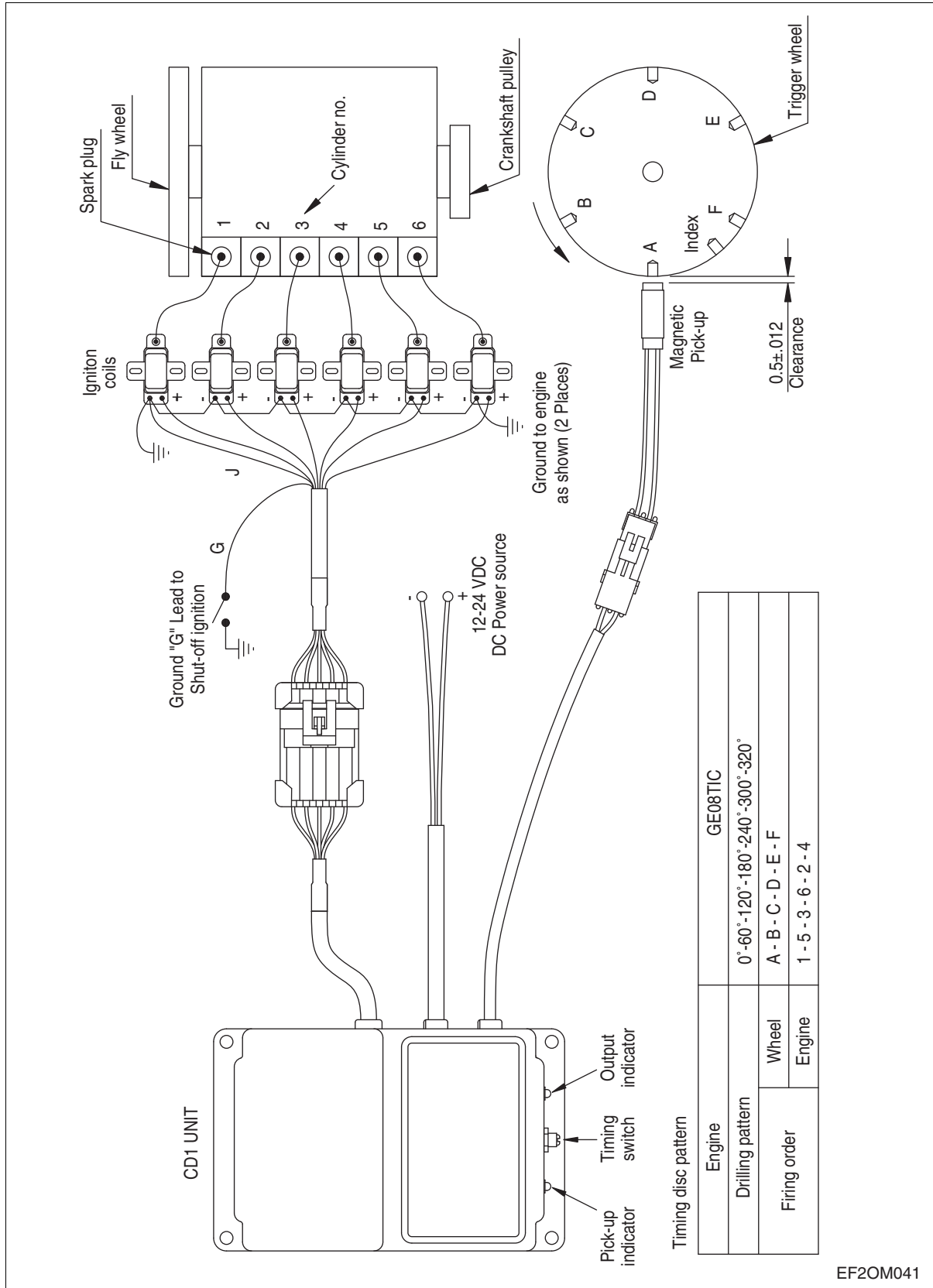

### 3.6.2. DC power hookup of ignition system

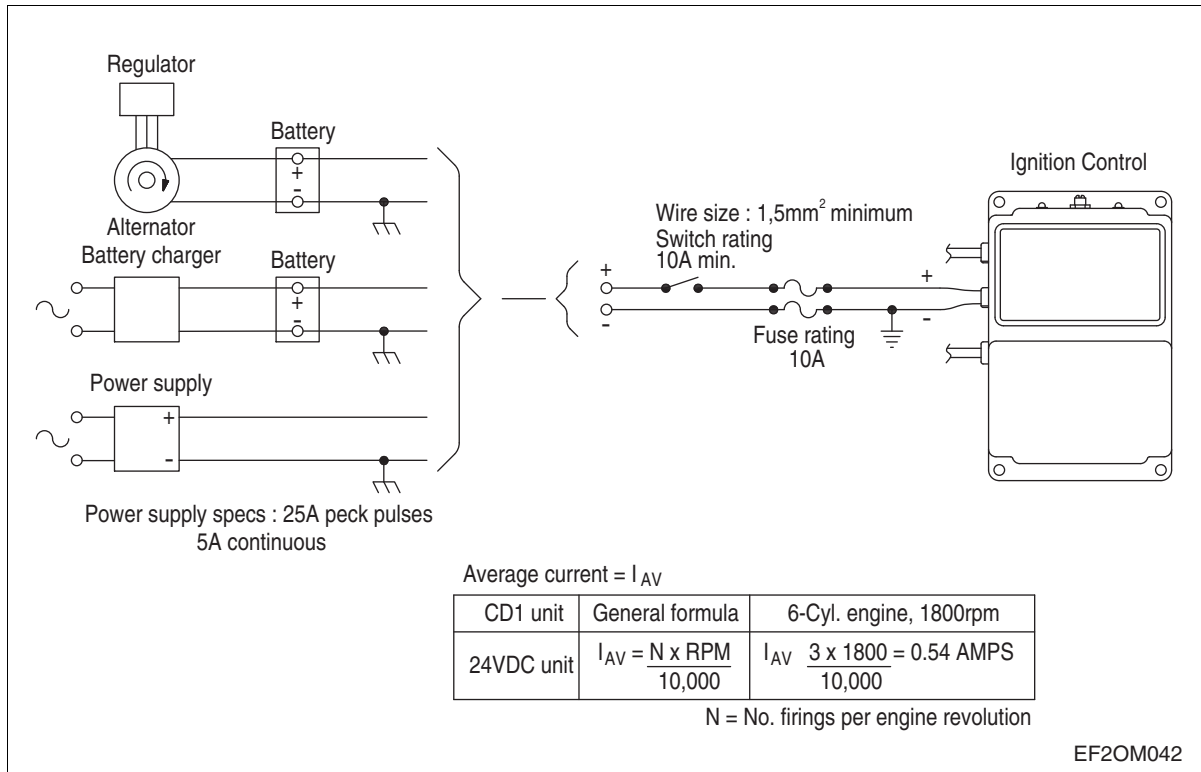

### 3.6.3. Engine firing order

Engine model	GE08TIC
Firing order	1 - 5 - 3 - 6 - 2 - 4

### 3.6.4. Engine cylinder no.

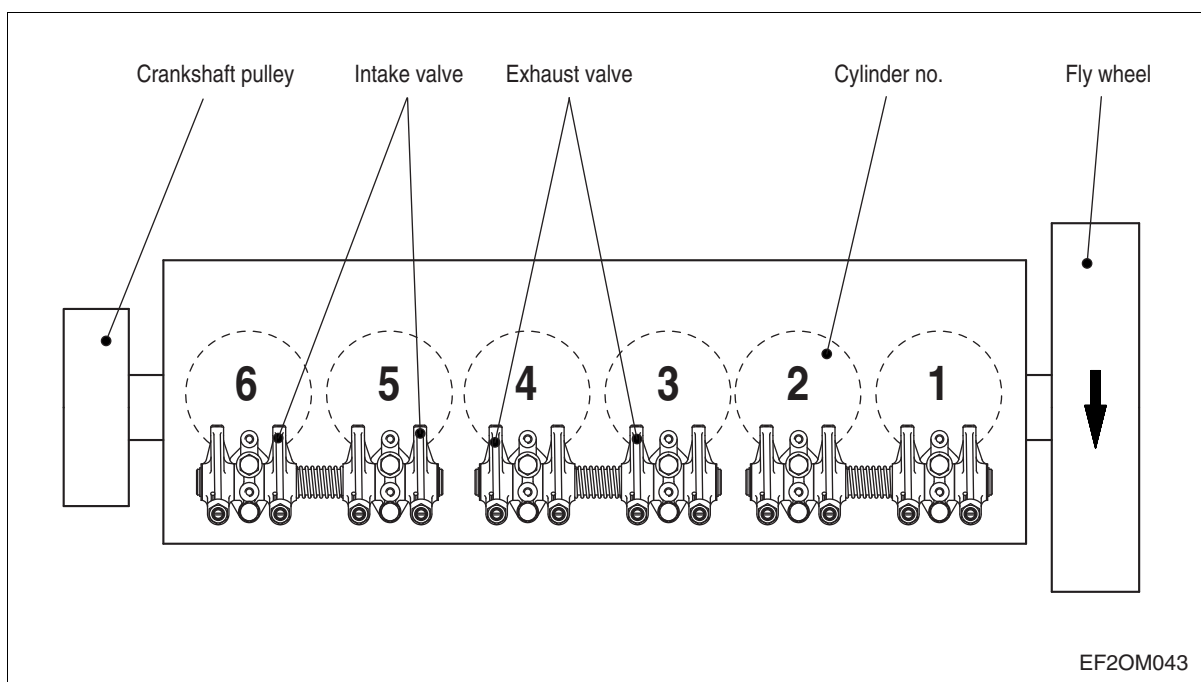

### 3.6.5. Primary wiring

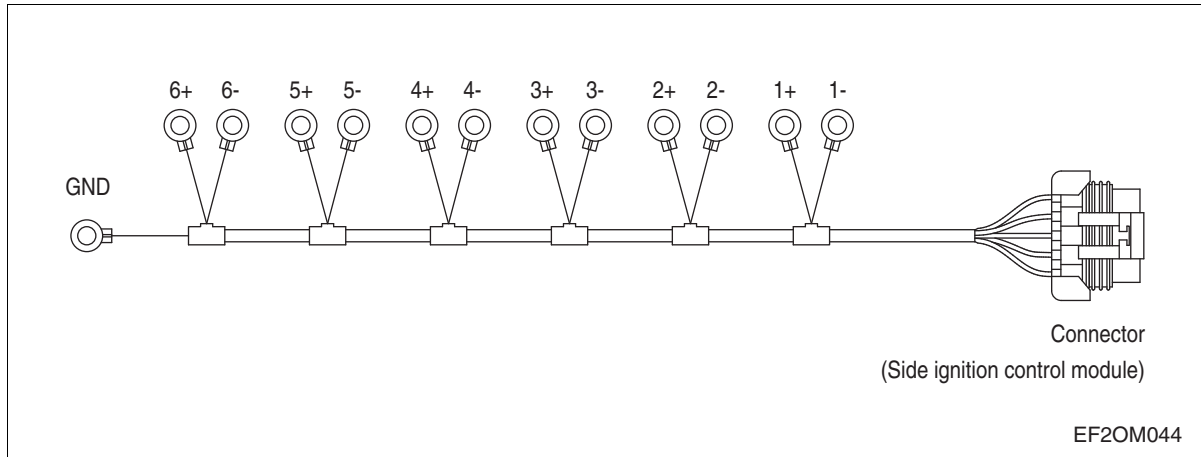

Terminal position	Terminal symbol	Wiring	Connector position
Spark coil	1+	1.25R	Connector A
	1-	1.25B	Connector J
	2+	1.25R	Connector E
	2-	1.25B	Spark coil 1-
	3+	1.25R	Connector C
	3-	1.25B	Spark coil 2-
	4+	1.25R	Connector F
	4-	1.25B	Spark coil 3-
	5+	1.25R	Connector B
	5-	1.25B	Spark coil 4-
	6+	1.25R	Connector D
	6-	1.25B	Spark coil 5-
	Ground	1.25B	Spark coil 6-

### 3.6.6. Tacho sensor wiring

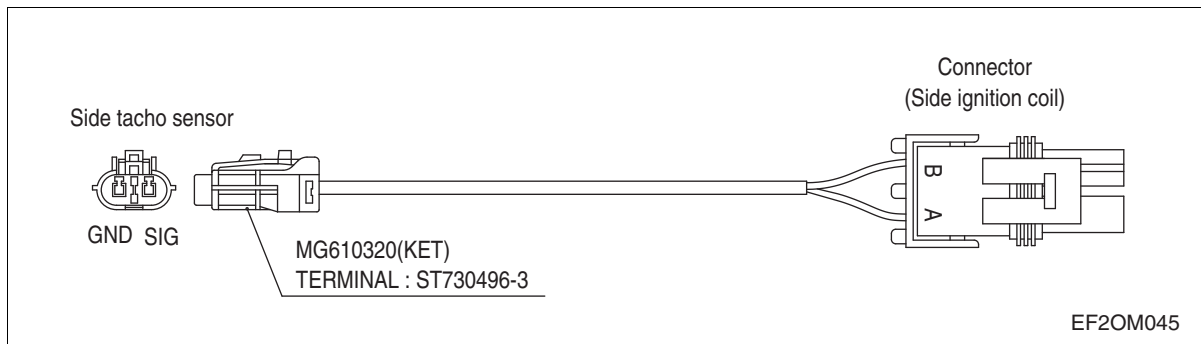

Terminal position	Terminal symbol	Wiring	Connector position
Tacho sensor	Tacho sensor	0.85W	Connector A
	Ground(GND)	0.85W	Connector B

## 3.7. Ignition control module

### 3.7.1. Installation instruction



**CAUTION:**

**Deviation from these installation instructions may lead to improper engine operation which could cause personal injury to operators or other nearby personnel.**

### 3.7.2. Description

- The CD1 ignition system consists of these basic components.
  - 1) CD1 unit
  - 2) Magnetic pick-up sensor
  - 3) Harness
  - 4) Individual coils
  
- The system requires a battery or a suitable power supply with a nominal 24 VDC. The CD1 unit steps up the DC supply voltage to charge an energy storage capacitor and contains microcircuit logic and SCR(Silicon controlled rectifier switching) devices to release the stored energy to the ignition coils in programmed, timed sequence according to the application. Holes drilled in the trigger wheel signal the position of the trigger coupling to the logic circuitry in the CD1 unit.

### 3.7.3. CD1 unit



- Select a location for the CD1 unit that will be at least 600 mm away from the ignition coils and spark plug leads. In addition, the mounting location must be relatively cool. The outside case temperature of the CD1 unit should not exceed 90°C (195°F) in operation.



**NOTE:**

**Plastic-case CD1 units have a maximum case temperature of 65°C (150°F).**

### 3.7.4. Pick-up sensor

- Locate a suitable mounting position for the pick-up sensor so that it may sense either the outside diameter of the trigger wheel.



#### **IMPORTANT:**

**Rotate the trigger wheel an entire revolution to be sure that there are holes in the path that will pass under the pick-up sensor.**

- Set the engine with no. 1 cylinder in the most advanced timing position. Mark the point on the trigger wheel that will be directly opposite the pick-up sensor.
- Drill the remaining holes spaced as shown in the appropriate wiring diagram in these instructions.



#### **NOTE:**

**The angular spacing is extremely important as this establishes the basic timing accuracy of the system. In addition, make sure each hole is drilled so that its center passes directly in line with the center of the pick-up sensor.**

- Secure the pick-up sensor to a rigid bracket or surface to maintain an air gap (1.0 mm  $\pm$  0.1 mm) not exceeding. The center of the pick-up face must line up with the center of the drilled holes as the engine is rotated.
- Plug the 2-pin pick-up sensor connector fully into its mating receptacle connected to the CD1 unit.



#### **NOTE:**

**Keep the pick-up sensor wires at least 50 mm away from the coil primary wires and at least 200 mm away from the spark plug leads.**

### 3.7.5. Trigger wheel

- A trigger wheel with the appropriate hole pattern must be prepared for mounting at camshaft speed. The angular spacing is extremely important as this establishes the basic timing accuracy of the system.
- Set the engine with no. 1 cylinder in the most advanced timing position. Noting the direction of rotation, set the drilled disc opposite the pick-up in the position shown in circuit diagram.
- Plug the 2-pin pick-up sensor connector fully into its mating receptacle connected to the CD1 unit.

### 3.7.6. Ignition coils

- Mount the ignition coils as close to the spark plugs as possible keeping the high-tension lead length to a minimum but also keeping temperatures below 95°C (200°F) during operation.

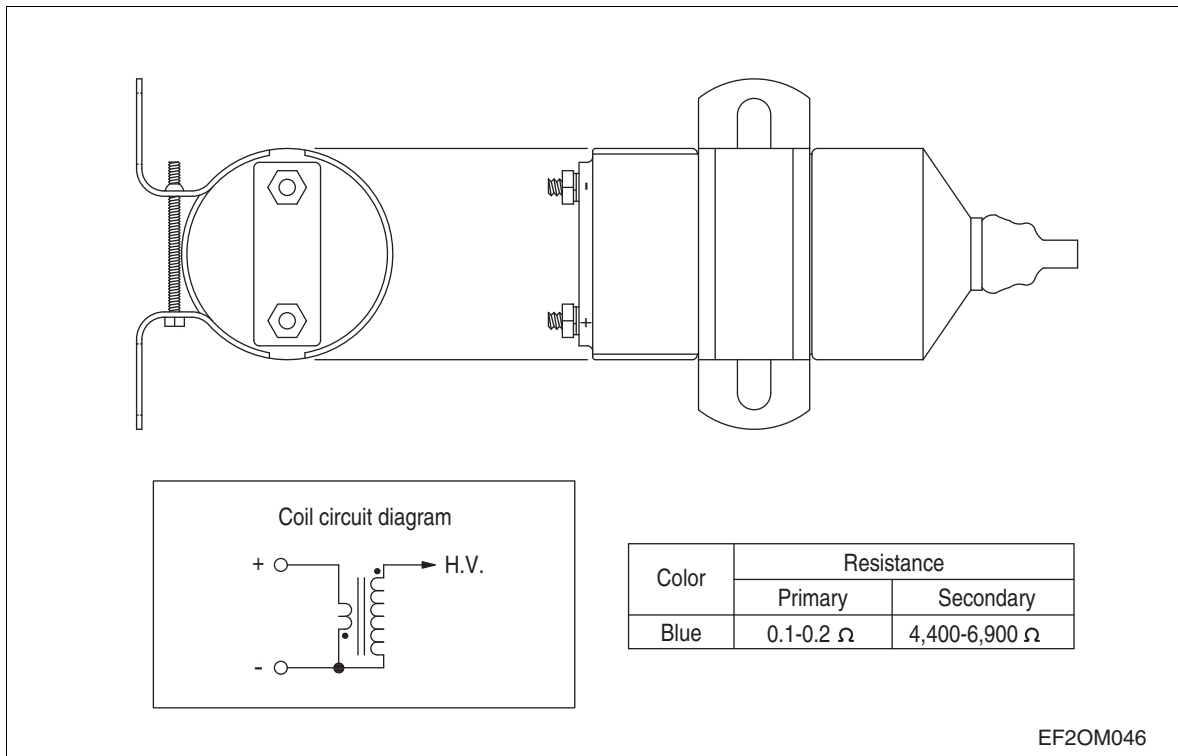

### 3.7.7. Primary wiring

- The CD1 system requires a battery or other DC power source providing 12~28VDC for running and a minimum of 8 volts for engine starting. Refer to details the connection to the DC power source.
- Plug the multi-pin harness connector fully into its mating receptacle connected to the CD1 unit.



#### NOTE:

Keep the primary wiring at least 50 mm away from the spark plug leads.

### 3.7.8. Shutdown wiring

The CD1 system can be shut-off in two ways.  
(Refer to Ignition controller circuit - CD1 system)

- **Method 1:** (use to DC power source)

Interrupt the DC power to the unit.

- Use a switch or relay with contacts rated 24VDC, 10 amps refer to drawing.
- Do not run the input power line through a series of normally closed switches.

● **Method 2:** (use to "G" ground)

- Ground the appropriate harness lead. This option may be used if the shutdown panel was powered from an ignition system.
- When the shutdown lead is grounded, the CD1 unit will draw about 0.1 amp from the power source.



**NOTE:**

**If desired, the shutdown lead may be used to power display instruments in the panel.**

### 3.7.9. Operation

- The CD1 unit steps up the DC supply voltage to charge an energy storage capacitor. SCR switching devices release this stored energy in response to signals from the unit's logic circuitry which processes signals from the magnetic pick-up. The pick-up senses one hole for every firing of the engine. Each firing occurs a programmed number of degrees after the hole is sensed. This delay in degrees is adjustable.
- The CD1 unit has a timing switch located under a white plastic cap at one end of the box.
  - 6 cylinder engine : 1.9 degrees per switch interval = 13 degrees total
- Switch position 7 gives the most advanced timing. The timing retards as indicated above for each switch position as the switch is moved to position 1-5-3-6-2-4. Switch position 0 is full retard.



**CAUTION:**

**Do not switch from position 7 to 0, or 0 to 7 while the engine is running. The large timing change may cause the engine to shutdown or be damaged.**



**NOTE:**

**Using a timing light, set the timing to the desired position with the engine running at normal operating speed. Replace the white cap over the timing switches once the proper timing setting is set.**

- Two LED indicators on either side of the timing switch give an indication of proper operation of the magnetic pick-up (left LED) and the output circuits of the CD1 unit (right LED). See troubleshooting procedures.

### 3.7.10. Troubleshooting chart

● Normal operation

Check the two LED indicators next to the timing switch.

- After power is turned on to the CD1 unit, the output indicator will turn on.
- When the engine is cranked, both indicators will blink at the same rate.
- At normal running speeds, both indicators glow continuously.
- If engine is stopped with power off, the output indicator will turn off for a few seconds and then stay on continuously.

● Trouble shooting

- Check the two LED indicators next to the timing switch.
- If the engine will not start or run correctly, crank engine with fuel turned off and check per the chart below.

Indication and checks	Remedy
1. Both indicators off. ● Check 12~24 VDC power to CD1 unit. ● If above check is OK.	● Must be in range of 12 ~ 29 VDC. ● Replace CD1 unit.
2. Pick-up indicator off / Output indicator On. 1) Check gap between pick-up and sensed surface. - must be greater than 1.0 mm ±0.1 mm. 2) Check connections between CD1 unit and the pick-up sensor. 3) Unplug connection to pick-up and measure resistance between the two pick-up leads. 4) If above checks are OK.	● Correct gap.  ● Correct connections.  ● Replace pick-up.  ● Replace CD1 unit.
3. Pick-up indicator OK / Output indicator off or blinks at slower rate. 1) Check connections between CD1 unit and ignition coil module or coils. 2) If above check is OK.	● Correct connections.  ● Replace CD1 unit.
4. Both indicators blink at the same rate. 1) Indicates proper operation of CD1 unit and magnetic pick-up sensor.	● Check or replace ignition coils. ● Check other items such as fuel supply.

## 3.8. Speed controller setting

### 3.8.1. Installation checks



Do the checks in the order indicated. Terminal numbers in this chapter refer to the speed controller.

- 1) Check that all electrical connections are correctly made and terminal screws tightened, the magnetic pickup is properly installed and the jam nut tightened, and the fuel valve and drain line are securely fastened and correctly installed.
- 2) Do not start the engine now. Turn on governor power. Check the battery voltage at terminals 1(+) and 2(-). It must be from 18 to 32Vdc.
- 3) If a signal generator is available : Attach the output to terminals 5 and 6, leaving the magnet pick-up connections off. Set the signal-generator output between 2 and 10 Vrms. If a signal generator is not available, proceed to step 8.
- 4) Set the signal-generator frequency to about half of idle speed. Close the **IDLE/RATED** switch. Turn the signal generator and governor power on. The voltage across terminals 3 and 4 should measure about 5Vdc (**START FUEL LIMIT** must be fully clockwise).
- 5) Set the signal generator for magnet pick-up frequency at rated speed. Close the **IDLE/RATED** switch. Set the external speed trim pot (if used) at mid position. Observe the output from terminals 3 and 4.
  - a) If the output is at max-fuel position (about 5Vdc), slowly turn the rated-speed potentiometer counterclockwise until the signal just begins to move to minimum.
  - b) If the output is at minimum, slowly turn the rated-speed potentiometer clockwise until the signal just begins to move to maximum.
  - c) Continue to adjust the rated-speed pot very slowly, trying to stop the signal between minimum and maximum. Stop adjusting when the signal moves slowly. It will not be possible to stop the motion. The rated-speed reference is now set very close to desired speed.
- 6) Open the **IDLE/RATED** switch. Set the signal generator for magnet pick-up frequency at idle speed. (Preset the idle speed only after presetting rated speed.)
  - a) If the signal is at maximum-fuel position, slowly turn the idle-speed potentiometer counterclockwise until the signal begins to move to minimum.
  - b) If the signal is at minimum, slowly turn the idle-speed potentiometer clockwise until the signal just begins to move to maximum.
- 7) Continue to adjust the idle-speed pot very slowly, trying to stop the signal between minimum and maximum. Stop adjusting when the signal moves slowly. It will not be possible to stop the signal. The idle-speed reference is now set very close to desired idle speed.

- 8) **If a signal generator is not available:** turn the rated speed pot fully counterclockwise. Turn the idle-speed pot fully clockwise. Remove the magnet pick-up wires from the speed control and measure resistance across the magnet pick-up wires. If the resistance is correct replace the connection.

### 3.8.2. Initial pre-start settings

In case the newly installed the speed controller does not control engine speed, be prepared to bellows sequence.

#### 1. Rated Speed

If **RATED SPEED** was not set with a signal generator, set the **RATED SPEED** potentiometer to minimum (fully counterclockwise). Set the external speed trim, if used, to mid-position.

#### 2. Stability

Set the **RATED** and **IDLE STABILITY** potentiometers to mid position.

#### 3. Gain

Set the **RATED** and **IDLE GAIN** potentiometers to mid position.

#### 4. Idle Speed

If **IDLE SPEED** was not set with a signal generator, set the **IDLE SPEED** potentiometer at maximum (fully clockwise).

#### 5. Start Fuel Limit

Set the **START FUEL LIMIT** pot at mid point (maximum is fully clockwise).

6. Close the circuit between terminals 9 and 10 (Close for rated).

### 3.8.3. Start-up and stable adjustments

Prepare to start the engine. Read this entire chapter before attempting to start the engine. Interrelated problems can occur, and an understanding of all possibilities is needed before using a control for the first time.



#### **CAUTION:**

**To protect against possible injury, loss of life, and/or property damage when starting the engine, turbine, or other type of prime mover, be prepared to make an emergency shutdown to protect against runaway or overspeed should the fuel control(s), the driving mechanism(s), or the control device(s) fail.**

- 1) Adjust for stable operation

Read the following paragraphs before attempting initial engine start up. Dynamics must be quickly adjusted after initial start up.

- 2) Immediately after the initial start up, it will be necessary to adjust the governor for stable operation. Idle and Rated dynamics are completely separate. In most cases the idle speed has been preset at maximum (fully clockwise) and Rated Speed is selected. In many cases the selection of rated speed will not indicate a desire for rated dynamics, which will be used when the engine is loaded. Idle dynamics may be selected and adjusted while rated speed is selected.
- 3) If the engine is hunting at a rapid rate, slowly decrease the **GAIN** (turn the potentiometer counterclockwise) until performance is stable.
- 4) If the engine is hunting at a slow rate, increase the **STABILITY** (turn the potentiometer clockwise) until the engine stabilizes. If increasing the **STABILITY** potentiometer does not stabilize the engine, it also may be necessary to slowly decrease the **GAIN** (turn the potentiometer counterclockwise).
  - a) Start cranking the engine. If the signal from terminals 3 and 4 does not show a positive voltage (2 to 6 Vdc) check the magnetic pick-up sensor.
  - b) Minimum voltage required from the magnetic pick-up sensor to operate the electronic control is 1.0 Vrms, measured at cranking speed or the lowest controlling speed. Measure the voltage while cranking with the speed sensor connected to the control. Be sure to prevent the engine from starting.
- 5) If the engine stops, it indicates a magnetic pick-up problem. The magnetic pick-up must produce a minimum of 1 Vac rms to activate the control. Failure to produce the minimum signal can be caused by improper magnetic pick-up installation, selection of an incorrect gear, improper wiring between the magnetic pick-up and the control, or a defective magnetic pick-up.
- 6) With the engine running and stable, slowly increase the rated-speed setting with the **RATED SPEED** pot until the desired rated speed is reached.
- 7) Dynamic adjustment

The object of the **GAIN** and **STABILITY** potentiometer adjustments is to obtain the optimum, or desired, stable engine-speed response.
- 8) Increasing the setting of the **GAIN** potentiometer provides faster transient response (decreases the amount of speed change from a sudden change in load).

To achieve the best response, slowly increase the **GAIN** (turn the potentiometer clockwise) until the engine becomes slightly unstable, then slowly turn the **GAIN** back counterclockwise as necessary to stabilize engine speed.
- 9) Step load the engine to make sure the engine returns to the proper speed with little overshoot or undershoot of the speed setting. (To reduce overshoot, increase the **STABILITY** setting by turning the potentiometer clockwise).
- 10) Increasing the **STABILITY** clockwise will require decreasing the **GAIN** (turning the **GAIN** potentiometer counterclockwise) to maintain stable operation.

11) If the engine is slow in returning to the proper speed, decrease the **STABILITY** by turning the potentiometer counterclockwise.

12) **Low idle speed adjustment:** The engine should be at rated speed with the **IDLE SPEED** potentiometer set at maximum (fully clockwise). Open the external **CLOSE FOR RATED** contact.

13) Decrease the **IDLE SPEED** (turn the potentiometer counterclockwise) until the desired idle speed is reached. It may be necessary to adjust the idle dynamics to maintain stability as speed is lowered.

14) Dynamic Adjustment

a) Gain is too high and stability too low. There are secondary overshoots on transients and large overshoots on starts (under damped)

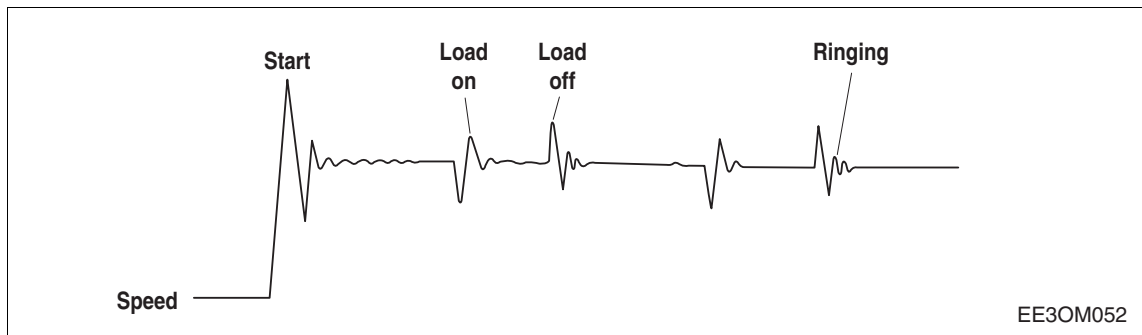

b) Optimum performance on load transients with slight overshoot on starts (optimum damping)

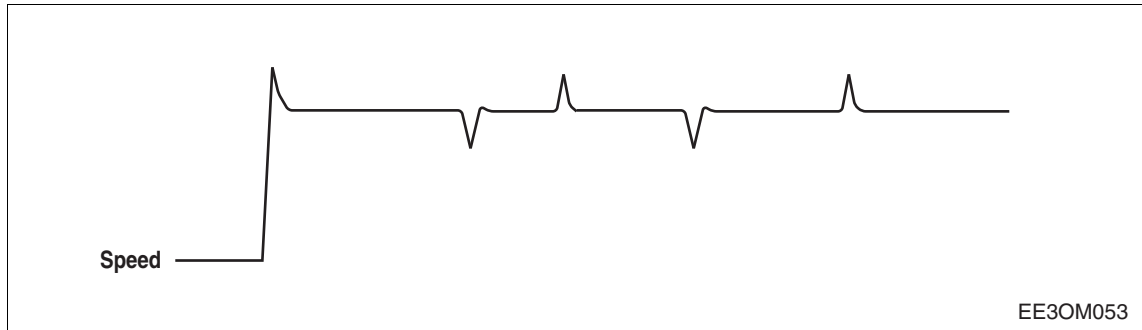

c) Optimum performance on start with slight time extension of load transients (optimum damping)

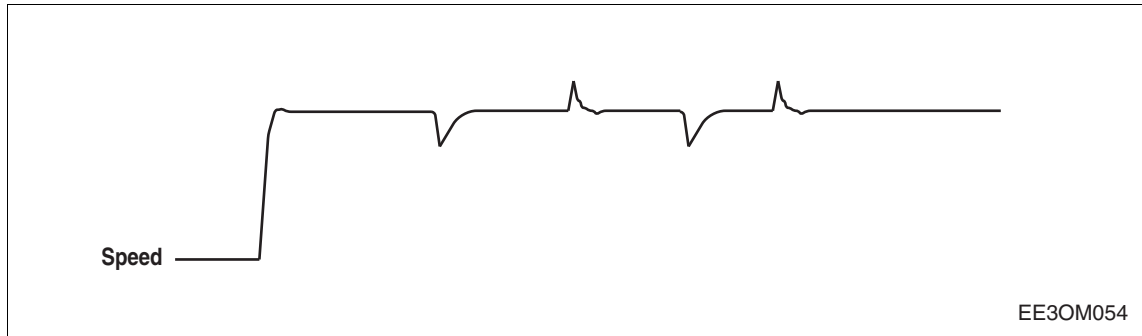

d) Stability too high, long time to settle to rated speed (over damped)

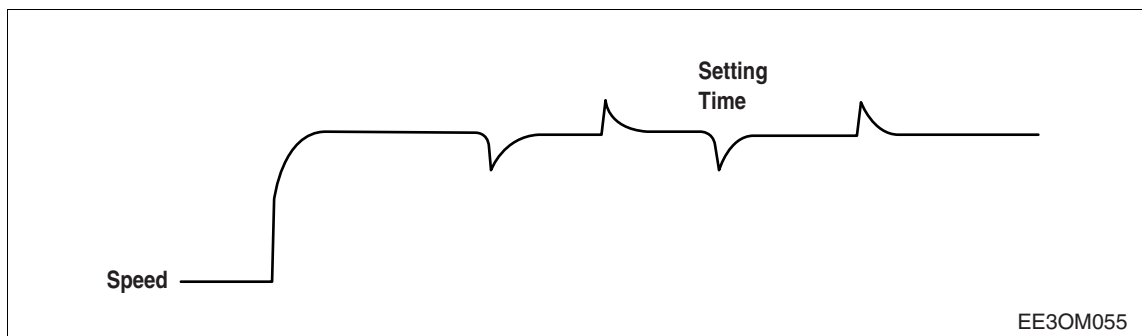

- 15) If idle. dynamics were selected on initial start-up, it will now be necessary to set rated dynamics. Load the engine, then select rated dynamics.
- 16) Engine response will change as the engine warms up. It may be necessary to tune dynamics after warm-up. It may be necessary to compromise optimum control dynamics with a cold engine in order to have optimum dynamics when the engine is at operating temperature.
- 17) The **START FUEL LIMIT** was set at a point that allowed the cold engine to start during initial start up procedures. If **START FUEL LIMIT** is to be used, it should now be adjusted after engine stability and response rates are correctly adjusted.
  - a) Adjusting the **START FUEL LIMIT** counterclockwise will prevent the fuel valve from delivering a maximum amount of fuel to the injectors until the selected speed (Idle or Rated) is reached. Adjust for desired engine performance during start up. The Start Fuel Limit must be set high enough to allow the engine to reach the selected speed.
  - b) The **START FUEL LIMIT** should be adjusted from counterclockwise to obtain the desired characteristics while starting the engine. There may be differences in startup characteristics of cold and hot engines.

## 4. Commissioning and Operation

### 4.1. Operation preparation

At the time of initial commissioning of a new or overhauled engine make sure to have observed the "Technical information for the installation HD Hyundai Infracore generator engines".

#### ● Oil filler neck on cylinder head cover

- Before daily starting of the engine, check the fuel, coolant and oil level, replenish if necessary.
- The notches in the oil level gauge indicate the highest and lowest permissible oil levels.



#### **IMPORTANT:**

**Do not fill above the top of the mark. Oil levels anywhere within the crosshatch are considered in the acceptable operating range. Over lifting will result in damage to the engine.**

#### ● Cleanliness

Ensure utmost cleanliness when handling fuels, lubricants and coolants

### 4.2. Breaking-in

#### 4.2.1. Preparations for breaking-in

- Fill of new engine oil through the oil filler cap.



- When measuring the oil level with the oil level gauge with the engine mounted, the oil level must indicate about 10 mm above the max. line.
- Connect water hoses and fill up cooling water.
- Connect the electrical systems such as starter, alternator, etc. with power source.

#### 4.2.2. Operation of a new engine (Break-In)

Because the sliding surfaces of a new engine are not lapped enough, the oil film can be destroyed easily by overload or overspeed and the engine life-time may be shortened. Therefore the following things must be obeyed by all means.

##### ***Up to the first 50 hours***

- Engine should be run at fast idling until the temperature of the engine becomes normal operating condition.
- Overload or continuous high speed operation should be avoided.
- High speed operation with no load should be prevented.
- Abrupt start and stop of the engine should be avoided.
- Engine speed must be under 70% of its maximum speed.
- Maintenance and inspection must be accomplished thoroughly.

### 4.2.3. Check points for break-in

During the break-in (the initial running of the engine) period, be particularly observant as follows:

- a) Check engine oil level frequently. Maintain oil level in the safe range, between the "min." and "max." marks on dipstick.



**Note :**

**If you have a problem getting a good oil level reading on dipstick, rotate the level gauge 180° and re-insert for check.**

- b) Watch the oil pressure warning lamp. If the lamp blinks, it may be the oil pick-up screen is not covered with oil. Check oil level gauge. Add oil to the oil pan, if required. Do not overfill. If level is correct and the status still exists, see your DEALER for possible switch or oil pump and line malfunction.



**Note :**

**Oil pressure will rise as RPM increases, and fall as RPM decreases. In addition, cold oil will generally show higher oil pressure for any specific RPM than hot oil. Both of these conditions reflect normal engine operation.**

- c) Watch the engine water temperature gauge and be sure there is proper water circulation. The water temperature gauge needle will fluctuate if water level in expansion tank is too low.

At the end of the break-in period, remove break-in oil and replace the oil filter. Fill oil pan with recommended engine oil. Refer to following table.

- The following oils are also recommended

SAE No.	API No.	Sulfated ash content
15W40	above CD or CE	Bellow 0.5%

\* Recommend oil : TOTAL LMG-405

Mobil Delvac super GEO 15W40

- Engine oil capacity

Engine oil capacity			
Engine model	in Oil pan		Total (lit)
	Max. (lit)	Min. (lit)	
GE08TIC	23	17	25

#### 4.2.4. Operating after break-in

When starting a cold engine, always allow the engine to warm up gradually. Never run the engine at full throttle until the engine is thoroughly warmed up. Be sure to check the oil level frequently during the first 1,000 km(50 hours) of operation, since the oil consumption will be high until the piston rings are properly seated.

#### 4.3. Inspections after starting

During operation the oil pressure in the engine lubrication system must be monitored. If the monitoring devices register a drop in the lube oil pressure, switch off the engine immediately. And the charge warning lamp of the alternator should go out when the engine is running.

- Do not disconnect the battery or pole terminals or the cables.
- If, during operation, the battery charge lamp suddenly lights up, stop the engine immediately and remedy the fault in the electrical system.
- Engine should be stopped if the color, the noise or the odor of exhaust gas is not normal.
- Confirm the following things through warning lamps and gauge panel.

##### 4.3.1. Pressure of lubricating oil

The normal pressure comes up to 1 kg/cm<sup>2</sup> (1.0 bar) at idling and 3 ~ 5 kg/cm<sup>2</sup> (3.0 ~ 4.9 bar) at maximum speed. If the pressure fluctuates at idling or does not reach up to the expected level at high speed, shut down the engine immediately and check the oil level and the oil line leakage.

##### 4.3.2. Temperature of cooling water

The cooling water temperature should be 79 ~ 95°C in normal operating conditions. Abnormally high cooling water temperature could cause the overheating of engine and the sticking of cylinder components. And excessively low cooling water temperature increases the fuel consumption, accelerates the wears of cylinder liners and shortens the engine life-time.

## 4.4. Operation in winter time

Pay special attention to the freezing of cooling water and the viscosity of lubricating oil.

### 4.4.1. Prevention against the freeze of cooling water

When not using anti-freeze, completely discharge the whole cooling water after engine running. The freeze of cooling water causes the fatal damages of the engine. Because the anti-freeze is used to prevent cooling water from freeze, consult "The amount of anti-freeze".

### 4.4.2. Prevention against excessive cooling

Drop of thermal efficiency caused by excessive cooling increases fuel consumption, therefore prevent the engine from excessive cooling. If the temperature of coolant does not reach to normal condition (79 ~ 95°C) after continuous operation, examine the thermostat or the other cooling lines.

### 4.4.3. Lubricating oil

As cold weather leads to the rise of oil viscosity, engine speed becomes unstable after starting. Therefore the lubricating oil for winter should be used to prevent this instability. Refer to lubricating system section.

## 4.5. Tuning the engine

The purpose of an engine tune-up is to restore power and performance that's been lost through wear, corrosion or deterioration of one or more parts or components. In the normal operation of an engine, these changes can take place gradually at a number of points, so that it's seldom advisable to attempt an improvement in performance by correction of one or two items only. Time will be saved and more lasting results will be obtained by following a definite and thorough procedure of analysis and correction of all items affecting power and performance.

Economical, trouble-free operation can better be ensured if a complete tune-up is performed once every years, preferably in the spring. Components that affect power and performance to be checked are:

- Components affecting fuel system ;  
Ignition coil, spark plug, metering valve etc.
- Components affecting intake & exhaust ;  
Air cleaner, inter-cooler, turbocharger, silencer, etc.
- Components affecting lubrication & cooling ;  
Air & oil filter, anti- freeze, etc.

## 4.6. Maintenance and care

### 4.6.1. Periodical inspection and maintenance

In order to insure maximum, trouble-free engine performance at all times, regular inspection, adjustment and maintenance are vital.

- Daily inspections in below figure should be checked every day.
- The maintenance should be executed thoroughly at regular intervals.  
(refer to appendix "General engine inspection cycle")

### 4.6.2. Exchanging of lubrication oil

Engine oil and the oil filter are important factors affecting engine life. They affect ease of starting, fuel economy, combustion chamber deposits and engine wear.

At the end of the break-in period 50hours change the oil sump oil and replace the oil filter cartridge.

### 4.6.3. Oil level gauge

Check the oil level in the engine sump daily with an oil level gauge.

- The notches in oil level gauge must indicate the oil level between the max. and the min. permissible.
- The oil level should be checked with the engine horizontal and only after it has been shut down for about 5 minutes.
- Examining the viscosity and the contamination of the oil smeared at the oil level gauge replace the engine oil if necessary.

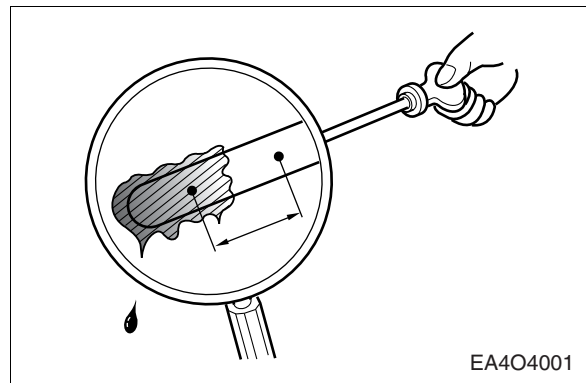

#### CAUTION:

**Do not add so much engine oil that the oil level rises above the max. marking on the oil level gauge. Over lifting will result in damage to the engine.**

#### 4.6.4. Oil exchange procedure

While the oil is still hot, exchange oil as follows:

- Take out the oil level gauge.
- Turn the valve opening and then move the oil drain pump lever as figure by hand, and let engine oil discharge into the prepared vessel
- Refill with new engine oil at the oil filler neck on the head cover and the lubricating oil in accordance with the oil capacity of the engine through oil filler. Be careful about the mixing of dust or contaminator during the supplement of oil. Then confirm that oil level gauge indicates the vicinity of its maximum level.
- For a few minutes, operate the engine at idling in order to circulate oil through lubrication system.
- Thereafter shut down the engine. After waiting for about 10 minutes measure the quantity of oil and refill the additional oil if necessary

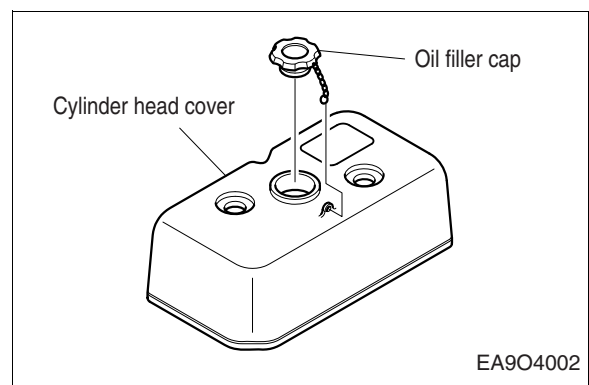
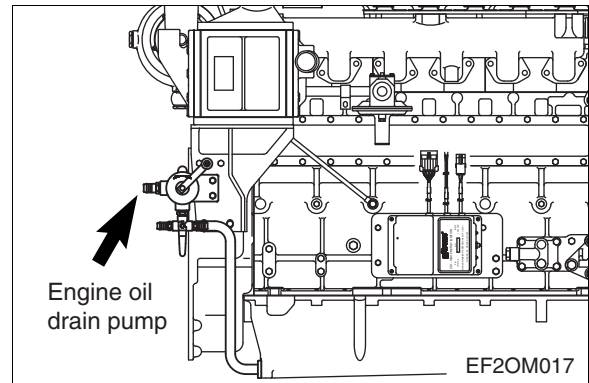

#### 4.6.5. Replacement of oil filter cartridge

- At the same times of oil exchanges, replace the oil filter cartridge.
- Drain engine oil by hand pump.



**IMPORTANT:**  
**Don't forget closing the drain pump after having drained engine oil.**

- Loosen the oil filter by turning it counterclockwise with a filter wrench.
- With a rag wipe clean the fitting face of the filter body and the oil filter body so that new oil filter cartridge can be seated properly.

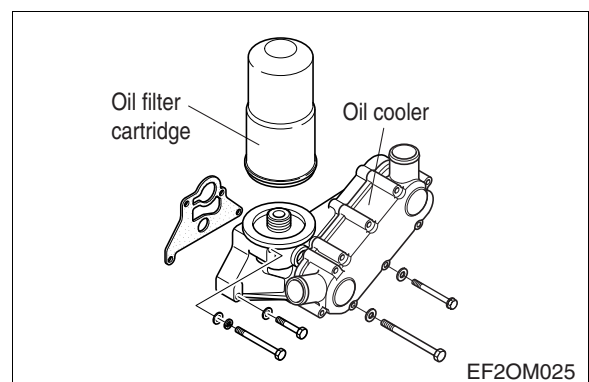

- Lightly oil the O-ring and turn the oil filter until sealing face is fitted against the O-ring. Turn 1-1/4 turns further with the filter wrench.



**NOTE:**

**It is strongly advisable to use HD Hyundai Infracore genuine oil filter cartridge for replacement.**

#### 4.7. Cooling system

The coolant must be changed at intervals of 1,200hours operation or 1year whichever comes first. If the coolant is being fouled greatly, it will lead an engine overheat or coolant blow off from the expansion tank.

##### 4.7.1. Coolant draining

- Remove the drain plug from the cylinder block and drain out the cooling water into a container.



**CAUTION :**

**When removing the drain plug while the engine is still hot, so that turn it slowly to release the internal steam pressure. This will prevent a person from scalding with hot steam spouted out.**

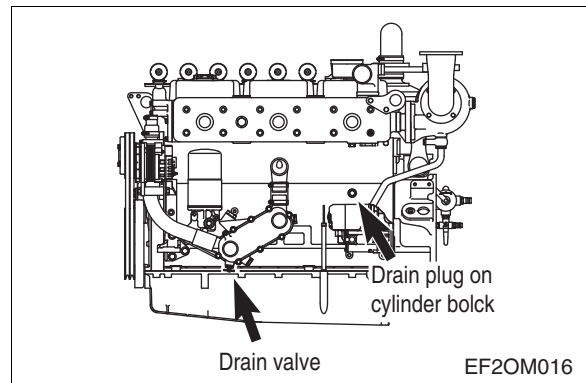

#### 4.7.2. Cleaning of the cooling inside system circuit

When the cooling system circuits are fouled with water scales or sludge particles, the cooling efficiency will be lowered. When the cooling system circuits are clogged, the water pump mechanical seal is damaged.

The poor condition of the cooling system is normally due to use of unsuitable or no anti-freezing agents and corrosion inhibitor or defect.

If twice in a short time (within 6 months) the water pump of an engine develops leaks or the coolant is heavily contaminated (dull, brown, mechanically contaminated, gray or black signs of a leakage on the water pump casing) clean the cooling system prior to removing that water pump as follows.

- a) Drain coolant.
- b) Remove thermostats, so that the whole cooling system is immediately flown through when cleaned.
- c) Fill the cooling system with a mixture of potable water and 1.5% by volume of cleaner. (Henkel P3T5175)
- d) Warm up engine under load. After a temperature of 60°C is reached, run engine for a further 15 minutes.
- e) Drain cleaning fluid.
- f) Repeat steps c) and d).
- g) Fill cooling system with hot water.
- h) Run engine at idle for 30 minutes. At the same time continuously replenish the water leaking from the bore in drain plug by adding fresh water.



**CAUTION:**

**Periodically clean the circuit interior with a cleaner.**

## 4.8. Adjustment of valve clearance

### 4.8.1. General information

The valve clearances are to be adjusted at the times of the following situations.

- After initial 1,000 km (50hours) operation.
- When the engine is overhauled and the cylinder heads are disassembled.
- When severe noise comes from valve train.
- When the engine is not normally operated, even though there is no trouble in the fuel system. The valve clearance of the cold engine are as follows.

### 4.8.2. Adjusting order of the valve clearance

- 1) After letting the #1 cylinder's piston come at the compression top dead center by turning the crankshaft, adjust the valve clearances.
- 2) Loosen the lock nuts of rocker arm adjusting screws and push the feeler gauge of specified value between a rocker arm and a valve stem and adjust the clearance with adjusting screw respectively and then tighten with the lock nut.
- 3) As for the valve clearance, adjust it when in cold, as follow.

Specified Value		Measurement Tolerance	
Intake Valve	Exhaust Valve	Intake Valve	Exhaust Valve
0.4 mm	0.4 mm	±0.05 mm	

- Adjusting Sequence of Valve Clearance (1 Type)

- By cranking the engine, let #6 cylinder's valves overlap.
- In time, adjust the valve clearance corresponding to " ⇨ " of lower lists.
- Adjust the valve clearance corresponding to " ➡ " of lower lists.
- After reinsuring the valve clearances, retighten if necessary.

- No. 1 Cylinder is located at the side where flywheel was installed.

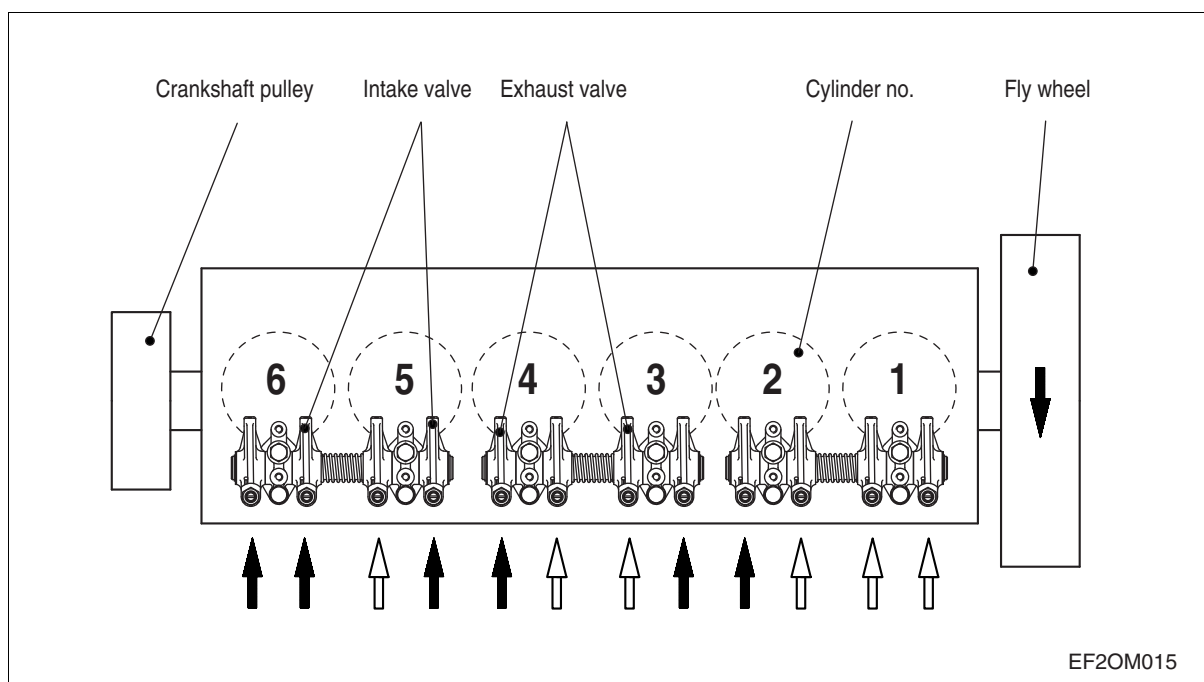

● Adjusting Sequence of Valve Clearance (2 Type)

1 Type is the conventional and simple method, but if you have some problem to adjust your engine, please try 2 type sequence. This is a precision method, but it takes more times.

Valve overlapping on cylinder (Intake & Exhaust valve)	1	5	3	6	2	4
Adjusting valves on cylinder (Intake & Exhaust valve)	6	2	4	1	5	3

**4.8.3. Method of adjusting the valve clearance**

- 1) Loosen the lock-nuts ① using a ring spanner.
- 2) Insert a thickness gauge of 0.3 mm between valve stem ② and rocker arm ③.
- 3) Turn the adjusting bolts ④ using a screw driver until the gauge can be pulled out with some restriction.
- 4) After the adjustment fix the adjusting bolt not to rotate and tighten the lock-nut at the same time.
- 5) Measure the clearance one more time and if necessary adjust again.

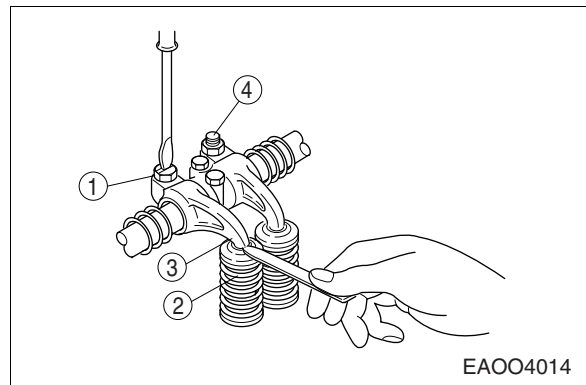

## 4.9. Tightening the cylinder head bolts

- The cylinder head bolts are to be tightened in the sequence shown in the illustrations, First tighten the bolts slightly, then slightly more again and finally tighten with a torque wrench.

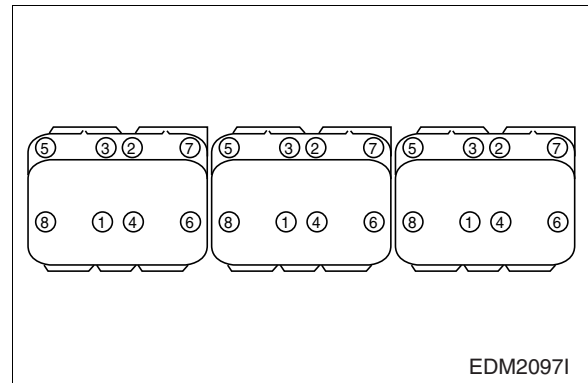

### <Cylinder head bolts>

Bolt	Type
Specification	 M14 x 1.5 x 146
Torque	1st : 6 kg.m 2nd : 90° 3rd : 90° 4th : 90° Final : 60° (Angle method)

### <Tightening order of bolts by steps>

- (1) First stage : Tighten 1 ~ 2 threads with hands.
- (2) Second stage : Tighten at about 6 kg.m with a wrench.
- (3) Third stage : Tighten at rotating angle method 90° with a wrench.
- (4) Fourth stage : Tighten at rotating angle method 90° with a wrench.
- (5) Fifth stage : Tighten at rotating angle method 90° with a wrench.
- (6) Sixth Stage : Finally tighten at rotating angle method 60° with a torque wrench.

- The tightening by excessive torque may cause the damages of the cylinder head gaskets, the flanges of cylinder liners and the cylinder head bolts, therefore obey the regular torque.



### CAUTION:

Do not reuse the cylinder head bolts when assembling the cylinder head.

#### 4.10. Cylinder compression pressure

- Stop the engine after warming it up, then remove the spark plugs.
- Install a special tool (gauge adapter) in spark plug hole and connect the compression pressure gauge to the adapter.
- Cut off fuel circulation, rotate the starter, then measure compression pressure of each cylinders.

Standard value	16 kg/cm <sup>2</sup> over
Limit value	13 kg/cm <sup>2</sup> or less
Difference between each cylinder	±10% or less

- Testing conditions:  
At water temperature of 20°C and speed of 200 rpm

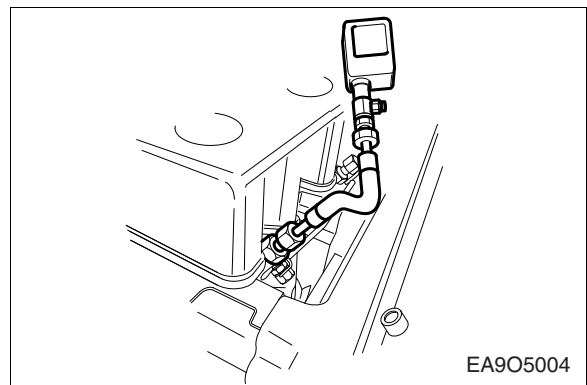
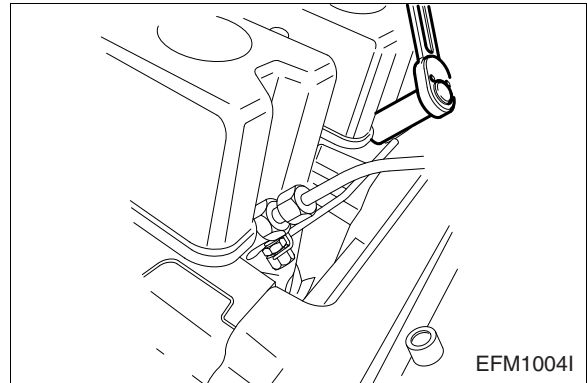

## 4.11. Belts

The tension of the belts should be checked after every 2,000 hours of operation.

### 1) Change the belts if necessary

If in the case of a multiple belt drive, wear or differing tensions are found, always replace the complete set of belts.

### 2) Checking condition

Check belts for cracks, oil, overheating and wear.

### 3) Testing by hand

By the finger-pressure the belt is pressed by 10 ~ 15 mm between the pulleys in normal condition. (Pressed mid-way between the belt pulleys)

A more precise check of the V-belt tension is possible only by using a V-belt tension tester.

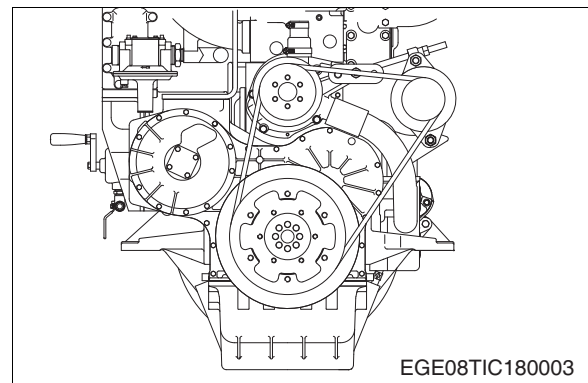
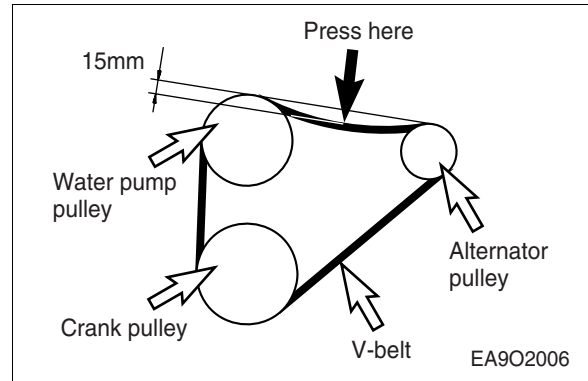

### 4) Measuring tension

(1) Lower indicator arm ① into the scale.

- Apply tester to belt at a point midway between two pulleys so that edge of contact surface ② is flush with the V- belt.
- Slowly depress pad ③ until the spring can be heard to disengage. This will cause the indicator to move upwards.
- If pressure is maintained after the spring has disengaged a false reading will be obtained.

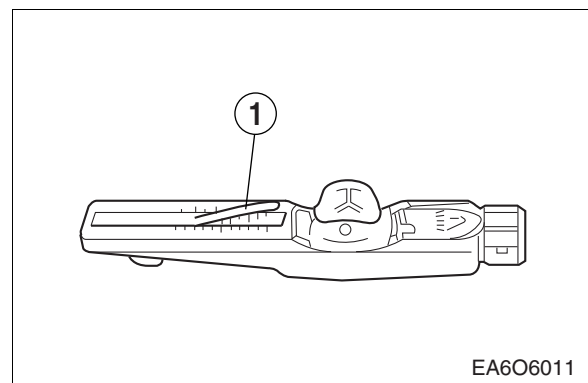

## (2) Reading of tension

- Read of the tensioning force of the belt at the point where the top surface of the indicator arm ① intersects with the scale.
- Before taking readings make ensure that the indicator arm remains in its position.

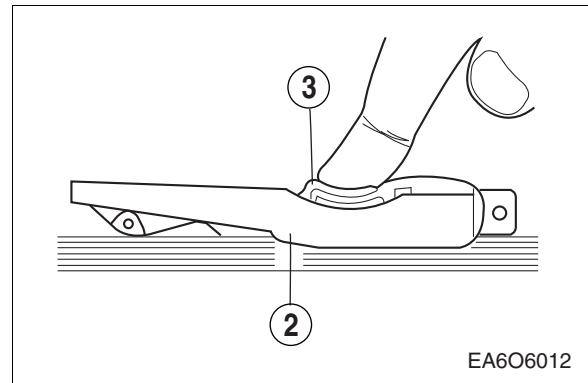

## ● V-belt tension

Type	Drive belt width	Tensioning forces on the tester		
		new installation		When servicing after long running time
		Installation	After 10 min. running time	
M	9.5 mm	50 kg	45 kg	40 kg
A	11.8 mm	55 kg	50 kg	45 kg
B	15.5 mm	75 kg	70 kg	60 kg
C	20.2 mm	75 kg	70 kg	60 kg

## 5) Tensioning and changing belts

- Loosen fixing bolts and nuts.
  - Adjust the alternator until belts have correct tensions.
  - Retighten fixing bolts and nuts.
- To change the belts loosen fixing bolts and nuts. Then push the alternator toward water pump pulley by hand.

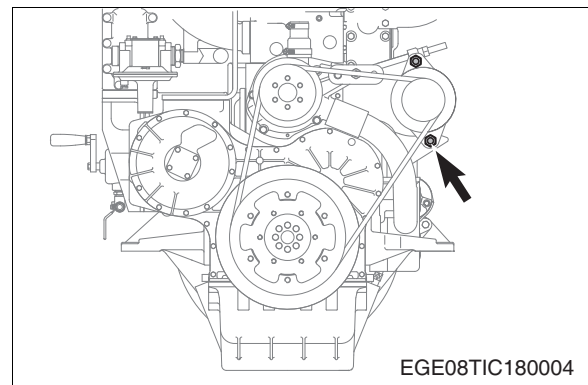

## 5. Maintenance of Major Components

### 5.1. Cooling system

#### 5.1.1. General information

- This engine is water-cooling type. Heat from the combustion chamber and engine oil heat are cooled down by coolant, resulting in the normal operation of the engine.
- Looking into the cooling system, the water pumped up by the water pump circulates around the oil cooler through the water pipe to absorb the oil heat, and then flows through the water jacket of the cylinder block and water passage of the cylinder head to absorb the heat of the combustion chamber.

#### GEN Pack

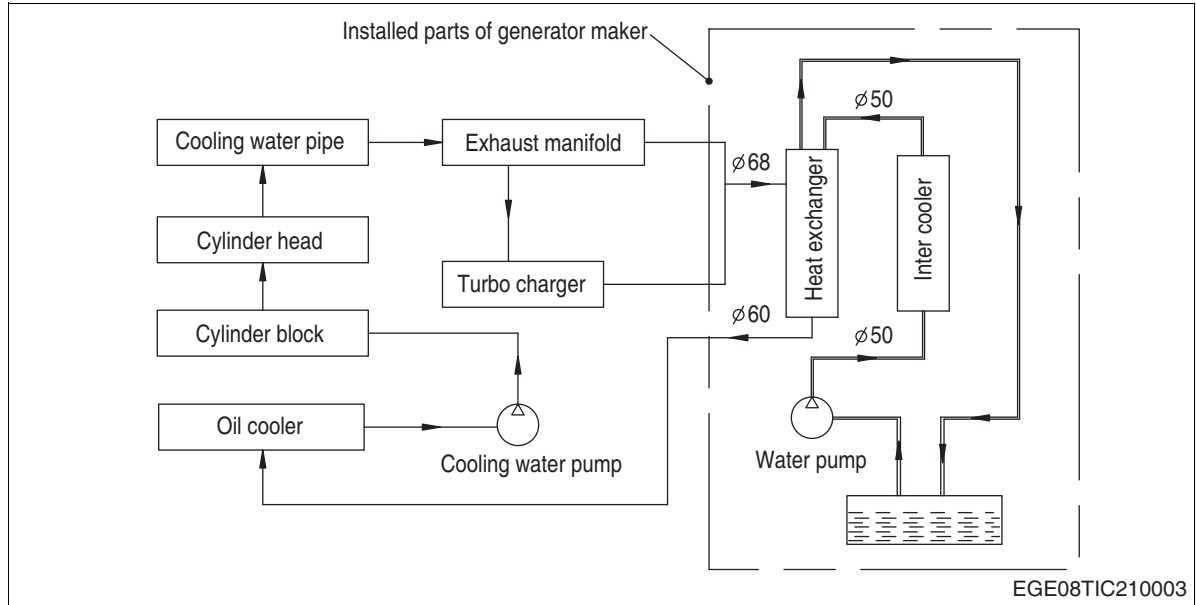

#### Specification

Item		Specification	
Water pump	Type	Centrifugal type	
	Pump speed	2,000 rpm	2,700 rpm
	Delivery capacity	about 190 liter/min	about 280 liter/min
	Operation pressure	0.5 bar	0.8 bar
	Allowable back pressure	bellow 0.5 bar	

## Half Engine

### TYPE1 : Dry Type

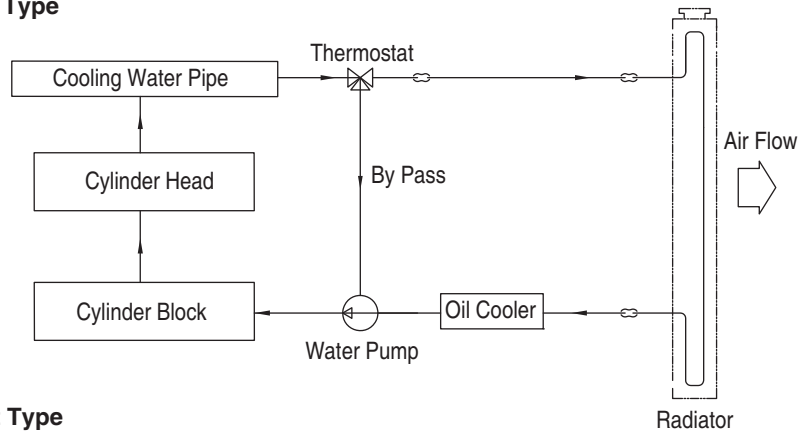

### TYPE2 : Wet Type

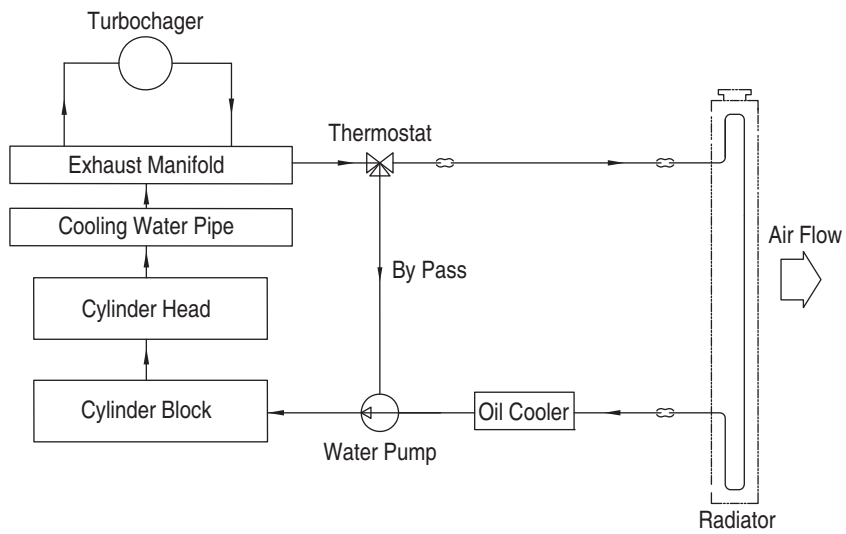

EGE08TIC210004

### 5.1.2. Diagnostics and troubleshooting

Complaints	Possible causes	Corrections
1. Engine overheating	<ul style="list-style-type: none"> <li>● Lack of coolan</li> <li>● Belt loosened or broken</li> <li>● Belt fouled with oil</li> <li>● Water pump defective</li> <li>● Restrictions in water pas- sages due to deposit of scales</li> <li>● Ignition timing incorrect</li> <li>● Gases leaking into water jacket due to broken cylinder head gasket</li> </ul>	<ul style="list-style-type: none"> <li>● Replenish coolant</li> <li>● Adjust or replace fan belt</li> <li>● Replace fan belt</li> <li>● Repair or replace</li> <li>● Clean intercooler and water passages</li> <li>● Adjust ignition timing cor- rectly</li> <li>● Replace cylinder head gas- ket</li> </ul>
2. Lack of coolant	<ul style="list-style-type: none"> <li>● Intercooler leaky</li> <li>● Intercooler hoses loosely connected or damaged</li> <li>● Water pump leaky</li> <li>● Cylinder head gasket leaky</li> <li>● Cylinder head or cylinder block cracked</li> </ul>	<ul style="list-style-type: none"> <li>● Correct or replace</li> <li>● Retighten clamps or replace hoses</li> <li>● Repair or replace</li> <li>● Replace cylinder head gas- ket</li> <li>● Replace cylinder head or block</li> </ul>
3. Cooling system noisy	<ul style="list-style-type: none"> <li>● Water pump bearing defec- tive</li> </ul>	<ul style="list-style-type: none"> <li>● Replace bearing</li> </ul>

## 5.2. Lubricating system

### 5.2.1. General descriptions and specifications

#### ● General descriptions

All the engine oil pumped up from the oil pan by the gear type oil pump is filtrated through the oil cooler and oil filter, and this filtrated oil is forced through the main oil gallery in the cylinder block from where it is distributed to lubricate the various sliding parts in order to ensure normal engine performance.

#### ● Specifications

Item	Specifications	Item	Specifications
Lubricating system	Forced pressure circulation	Oil filter type	Full flow
Oil pump type	Gear type	Bypass for filter element	
Relief valve opening pressure	$10 \pm 1.5 \text{ kg/cm}^2$	Valve opening pressure	$1.8 \sim 2.3 \text{ kg/cm}^2$
Bypass for oil cooler		Bypass for entire oil filter	
Opening pressure	$5 + 1 \text{ kg/cm}^2$	Valve opening pressure	$4.0 \sim 4.8 \text{ kg/cm}^2$
Adjusting valve for spray nozzle			
Opening pressure	$1.5 \sim 1.8 \text{ kg/cm}^2$		

#### ● Diagram of lubricating system

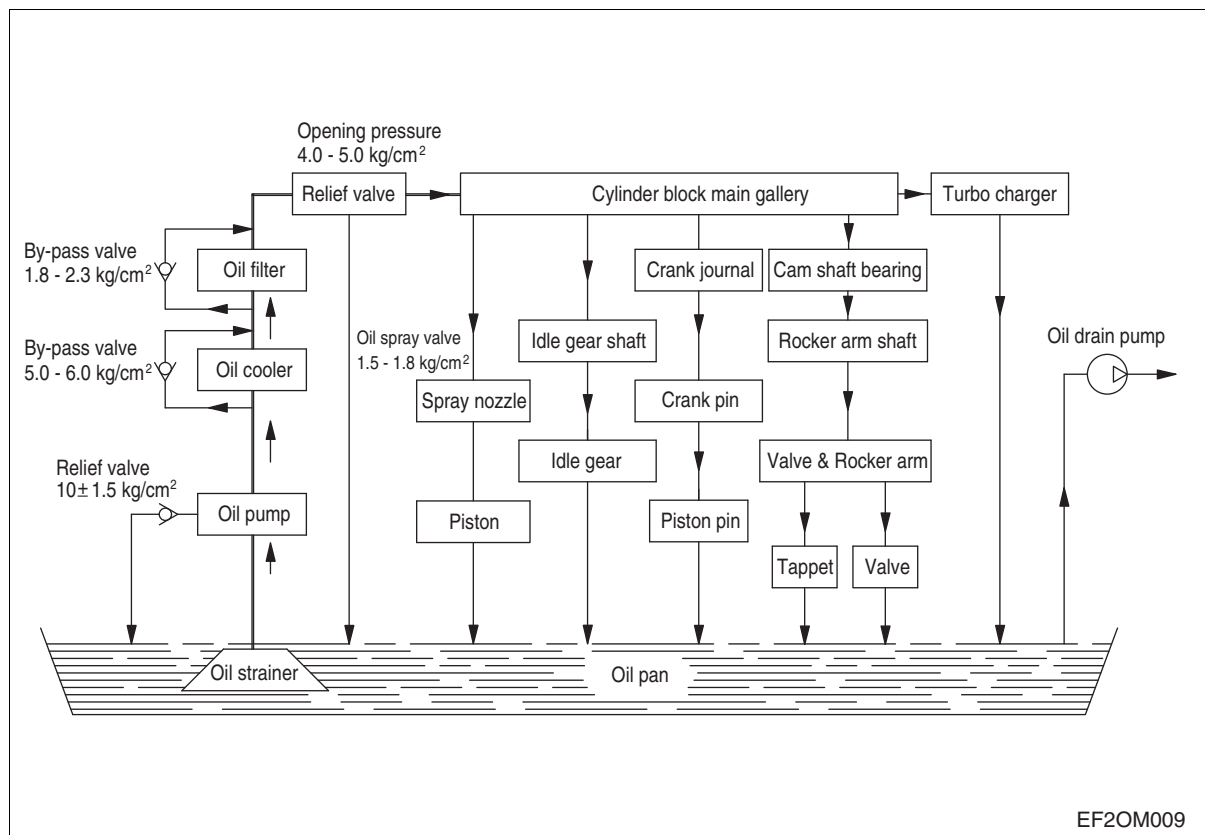

## 5.2.2. Oil pump

### ● Disassembly

- (1) Disassembly of oil pump drive gear
  - a. Unscrew the screw and disassemble the oil relief valve.
  - b. Unfold the washer for the oil pump drive gear fixing nut and remove the nut.
  - c. Disassemble the drive gear.

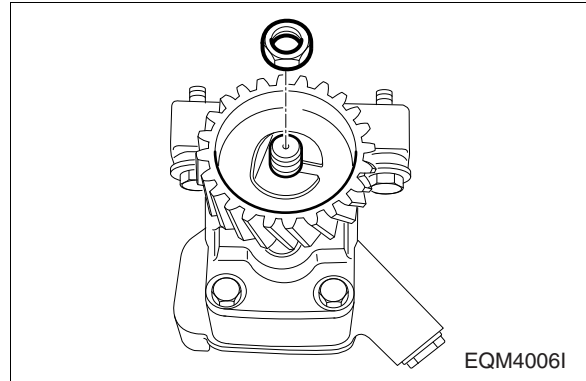

- (2) Remove the oil pump cover fixing nuts and disassemble the oil pump cover. The oil pump cover is fixed with the two dowel pins.

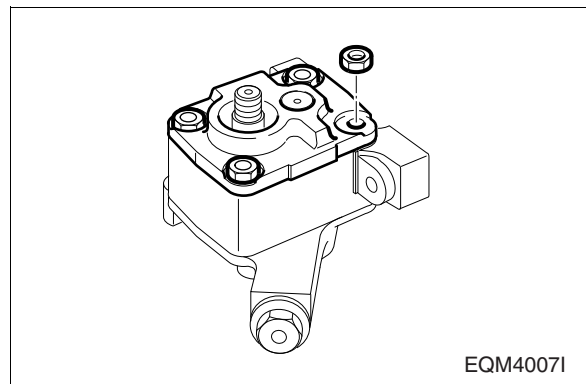

- (3) Disassemble the drive gear and driven gear.

### ● Inspection and correction

- (1) With steel rule and feeler gauge, measure the axial end play of the oil pump gear. Replace if the measured value is beyond the limit.

End play limit	0.025 ~ 0.089 mm
----------------	------------------

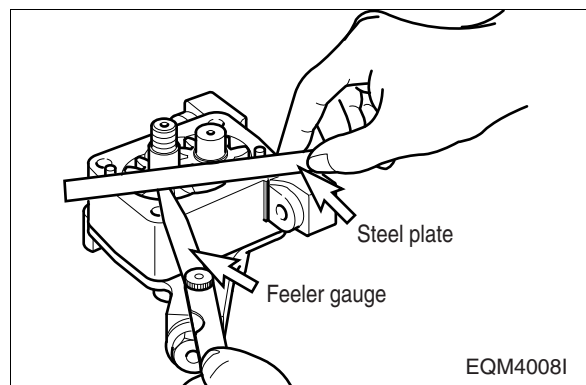

- (2) With a feeler gauge, measure the amount of backlash between the oil pump drive gear and driven gear. Replace if the measured value is beyond the limit.

Backlash limit	0.50 ~ 0.64 mm
----------------	----------------

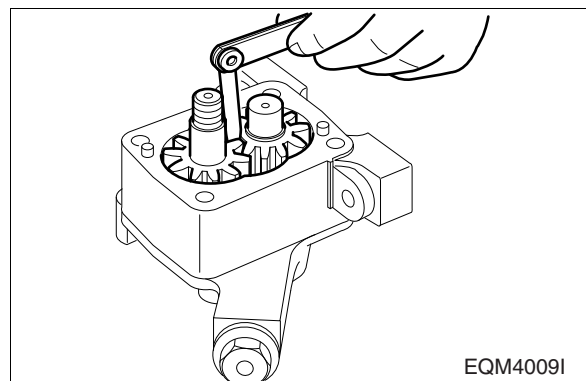

(3) Measuring clearance between drive shaft and bushing

a. Measure the outside diameters of the drive shaft and driven shaft, and replace if the measured values are less than the limit ( $\phi$  16.95 mm)

Standard	$\phi$ 16.95 ~ $\phi$ 16.968 mm
----------	---------------------------------

b. Measure the inside diameter of the pump body bushing to determine the clearance between the bushing and shaft, and compare the measured value with the standard value to determine whether to replace or not.

Clearance	0.032 ~ 0.077 mm
-----------	------------------

● **Reassembly**

(1) For reassembly, reverse the disassembly sequence.

### 5.2.3. Diagnostics and troubleshooting

Complaints	Possible causes	Corrections
1. Oil consumption excessive	<ul style="list-style-type: none"> <li>● Poor oil</li> <li>● Oil seal or packing leaky</li> <li>● Pistons or piston rings worn</li>   <li>● Cylinder liner worn</li> <li>● Piston rings sticking</li>   <li>● Valve guide oil seals or valve guides, or valve stem worn</li> </ul>	<ul style="list-style-type: none"> <li>● Use suggested oil</li> <li>● Replace</li> <li>● Replace pistons and/or piston rings</li> <li>● Replace cylinder liner</li> <li>● Replace pistons and/or piston rings</li> <li>● Replace</li> </ul>
2. Oil pressure too low	<ul style="list-style-type: none"> <li>● Poor oil</li> <li>● Relief valve sticking</li> <li>● Restrictions in oil pump strainer</li> <li>● Oil pump gear worn</li> <li>● Oil pump feed pipe cracked</li> <li>● Oil pump defective</li> <li>● Oil pressure gauge defective</li> <li>● Various bearings worn</li> </ul>	<ul style="list-style-type: none"> <li>● Use suggested oil</li> <li>● Replace</li> <li>● Clean strainer</li>   <li>● Replace</li> <li>● Replace</li> <li>● Correct or replace</li> <li>● Correct or replace</li> <li>● Replace</li> </ul>
3. Oil deteriorates quickly	<ul style="list-style-type: none"> <li>● Restriction in oil filter</li> <li>● Gases leaking</li>   <li>● Wrong oil used</li> </ul>	<ul style="list-style-type: none"> <li>● Replace filter element</li> <li>● Replace piston rings and cylinder liner</li> <li>● Use suggested oil</li> </ul>

## 5.3. Turbocharger

### 5.3.1. Main data and specifications

#### 1) Main data and specifications

Specification		GE08TIC
Turbocharger model		HX35G
at maximum out-put	Air pressure at compressor outlet	1.8 kg/cm <sup>2</sup>
	Air suction volume	16.8 m <sup>3</sup> /min
	Speed of turbine revolution	80,000 rpm
Maximum allowable speed		130,000 rpm
Max. allowable temperature of exhaust gas at turbine inlet		720°C
Lubricating system		External oil supply
Weight		14 kg

#### 2) Construction

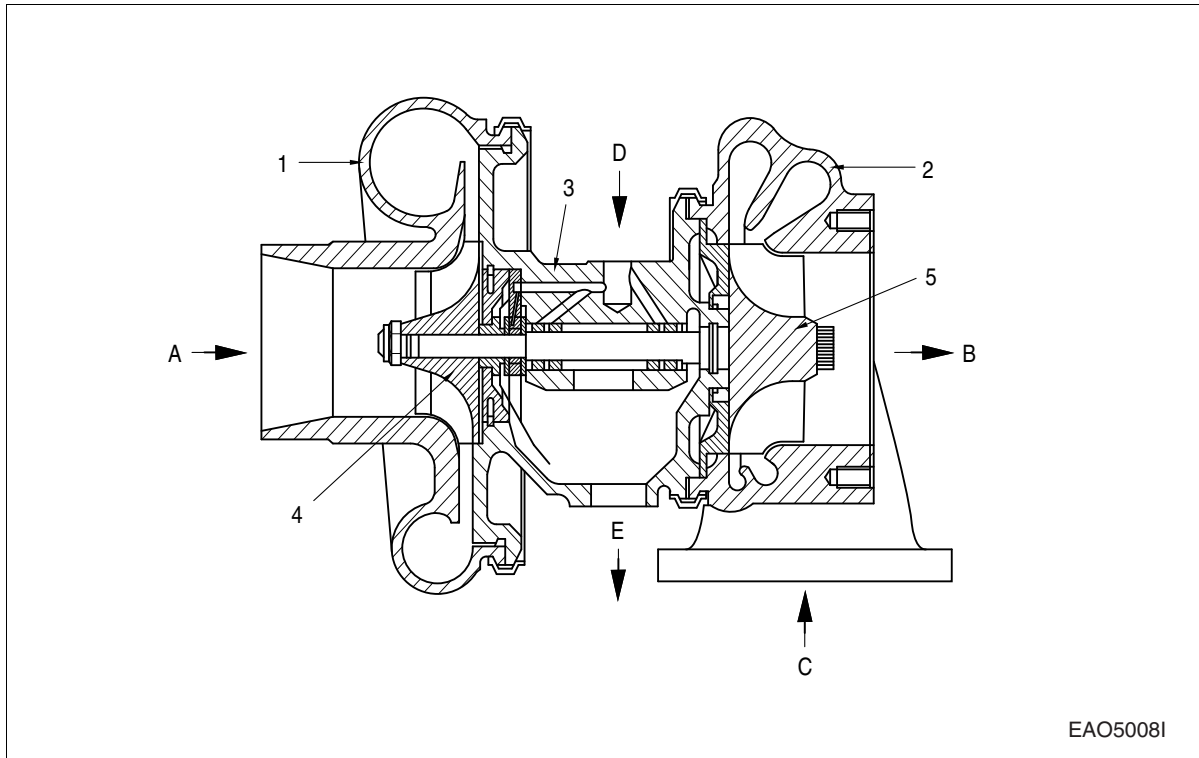

1. Impeller casing
2. Turbine casing
3. Bearing casing
4. Impeller
5. Turbine

- A. Air inlet
- B. Gas outlet
- C. Gas inlet
- D. Oil supply
- E. Oil return

### 3) Operating principle

The turbocharger is a system designed to make use of the engine exhaust gas energy to charge high-density air into the cylinders, thereby to increase the engine output.

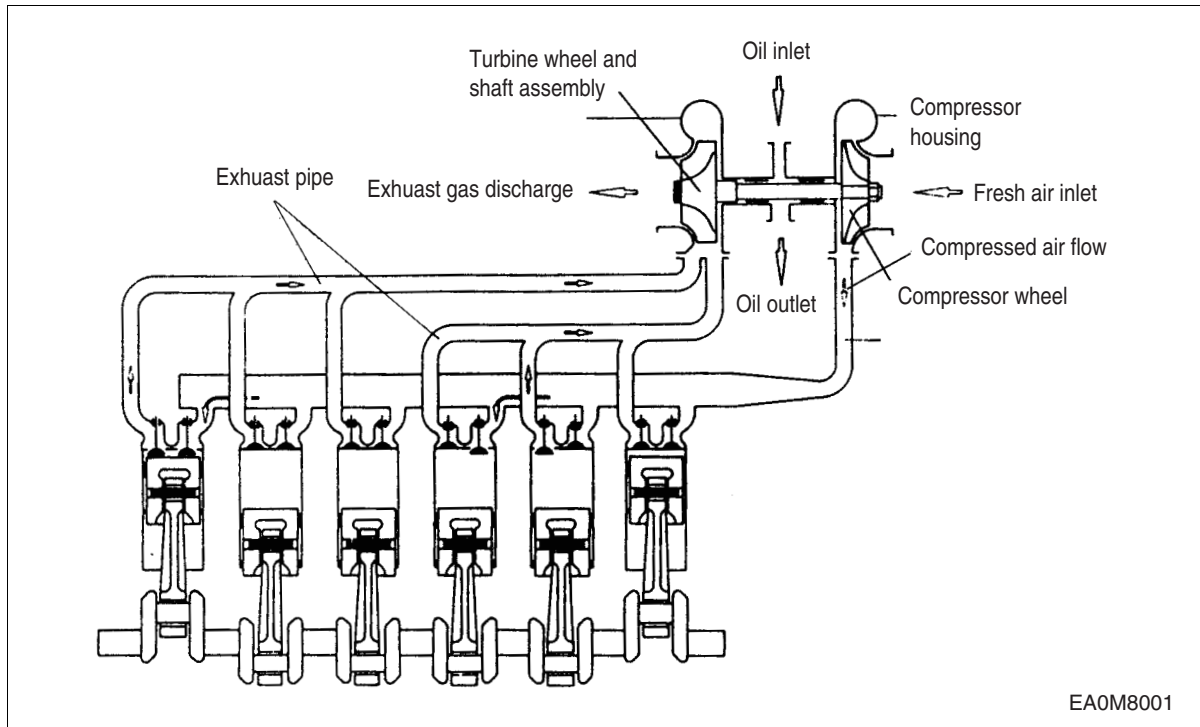

#### 5.3.2. General descriptions

The engine output is determined by the fuel delivery volume and engine efficiency.

To burn the supplied fuel completely to change into effective power for the engine, the volume of air enough to burn the fuel completely should be supplied into the cylinders.

Therefore, the engine output is determined substantially by the cylinder capacity, and a greater volume of compressed air is charged into cylinders of given capacity, the greater engine output can be obtained as a greater volume of air charged into the cylinders burns so much more fuel.

As explained, the compressing of air to supply into the cylinders is called "Supercharging" and the making use of the energy of exhaust gas discharged from the combustion chamber to charge the compressed air into the cylinders is called "Turbocharging".

### **5.3.3. Functions**

#### **1) Turbine**

Exhaust gas discharged from the combustion chamber distributes its own energy to the turbine blades while passing the inside of the turbine housing, with the result that the turbine shaft can get rotating force. This is the operating principle of 'turbine', which is mounted with seal rings and heat protector to prevent exhaust gas from affecting the bearings adversely.

#### **2) Compressor**

The compressor, which is connected to the turbine over the one and same shaft to form a rotating body, takes in and compresses ambient air with rotating force transmitted from the turbine shaft. Then, the compressed air is delivered to the intake stake. This is the operating principle of the compressor.

#### **3) Bearings**

##### **(1) Thrust bearing**

The turbine wheel creates thrust force. Therefore, exercise care so that the shaft is not deviated from its the original position due to this thrust.

##### **(2) Journal bearing**

This journal bearing of floating type forms a dual oil film on both the inside and outside of the bearing so that the bearing can rotate independently. As the dual oil film plays a role as a damper, the sliding speed of the bearing surface becomes lower than the rotating speed of the shaft, resulting in assurance of stability in its movement.

#### **4) Sealing - Compressor shaft**

The compressor is of a dual construction type composed of seal plate and seal ring to prevent the leak of compressed air or lubricating oil.

### 5.3.4. Precautions for operation

#### 1) Precautions for operation of engine

The following precautions should be observed when starting, operating, or stopping the engine:

Operations	Precautions	Reasons
When starting the engine	<ol style="list-style-type: none"> <li>1) Check oil level</li> <li>2) Crank the engine with starter to check the increase in oil pressure (until the needle of pressure gauge starts to move or pressure indicator lamp is actuated) before starting the engine.</li> <li>3) When having replaced oil, oil filter element, or lubricating parts, or when having stopped the engine for extended period of time, or in a cold place, loosen the oil pipe connections and operate the starter motor until oil is discharged. After completing the operation, be sure to retighten the oil pipe connections portion before starting the engine.</li> </ol>	<ol style="list-style-type: none"> <li>2) Abrupt starting of the engine causes the engine to rotate with oil not being distributed not only to each part but also to the turbocharger, resulting in abnormal wear or seizure on the bearing due to insufficient supply of oil.</li> <li>3) In the case of the engine stopped for extended time or in a cold place, oil fluidity within the pipes can be deteriorated</li> </ol>
Immediately after starting	<ol style="list-style-type: none"> <li>1) Run the engine at idle for 5 minutes after starting off.</li> <li>2) Check each part for leakage of oil, gas, and air, and take proper measure.</li> </ol>	<ol style="list-style-type: none"> <li>1) Applying load abruptly If load is abruptly applied with the engine and turbocharger rotating unsmoothly, such parts that a sufficient amount of oil has not reached can be seized up.</li> <li>2) Leakage of oil, gas, and air (especially, oil leak) causes drop in oil pressure and loss of oil results in seizure of the bearing.</li> </ol>
During operation	<p>Check the followings:</p> <ol style="list-style-type: none"> <li>1) Oil pressure At idle: 0.8 kg/cm<sup>2</sup> or more At full load: 3.0 ~ 4.8 kg/cm<sup>2</sup></li> <li>2) If unusual sound or vibration is heard or felt, reduce engine revolutions slowly and locate the cause.</li> </ol>	<ol style="list-style-type: none"> <li>1) Excessively low oil pressure causes unusual wear or seizure of the bearing. Too high pressure causes oil leakage.</li> <li>2) The engine is operated continuously with unusual sound or vibration not corrected, it can be damaged beyond repair.</li> </ol>
When stopping the engine	<ol style="list-style-type: none"> <li>1) Run the engine at idle for 5 minutes before stopping.</li> </ol>	<ol style="list-style-type: none"> <li>1) If the engine is put to a stop after being operated at high load, heat from the red-hot turbine blades is transmitted to the bearing portion and burns oil to cause seizure of the bearing metal and rotating shaft.</li> </ol>

### 5.3.5. Walk-around check and servicing

As the condition of turbocharger depends greatly on how well the engine is serviced, it is very important to maintain the engine in accordance with the specified maintenance procedure.

#### 1) Intake system

Pay particular attention to the air cleaner when servicing the intake system.

In the case of wet-type air cleaner, if the level of oil surface is lower than specified, cleaning effect is poor; if too high, the cleaner draws in oil to foul the case.

Especially, if the rotor is fouled, the sophisticatedly-tuned balance is broken to create vibration and to cause seizure and unusual wear to the bearing.

Therefore, it is very important to use a good quality air cleaner all the time.

In the case of dry-type air cleaner, it is essential to clean it to reduce intake resistance as much as possible.

#### 2) Exhaust system

Pay particular attention to prevent gas leaks and seizure when servicing the exhaust system because leakage of exhaust gas from discharge pipes, turbocharger fixing portions, etc. lowers charging effect.

As such components as turbine chamber that becomes red-hot during operation use heat resisting steel nuts, do not interchange these nuts with ordinary steel nuts. In addition, apply anti-seizure coating to fixing nuts on the portions as designated.

#### 3) Lubricating system

Pay particular attention to oil quality and oil filter change intervals when servicing the lubricating system. Deteriorated engine oil affects adversely not only the engine but also the turbocharger. Suggested engine oils for the turbocharger-mounted engine are as follows:

Engine model	Recommend oil		Sulfated ash content
	SAE No.	API No.	
GE08TIC	SAE 15W40	above CD or CE	Bellow 0.5%

Recommend oil : TOTAL LMG-405

Mobil Delvac super GEO 15W40

### 5.3.6. Periodical checking and servicing

Make it a rule to check the turbocharger assembly for condition and contamination periodically.

#### 1) Guide for checking the rotor for rotating condition

The inspection of the rotor assembly for rotating condition should be performed by the degree of unusual sound. If a sound detecting bar is used, install its tip on the turbocharger housing and increase the engine revolutions slowly. If a high-pitch sound is heard continuously, it means that the rotor assembly is not normal. In this case, as the metal bearing and rotor are likely to be in abnormal conditions, the turbocharger should be replaced or repaired.

#### 2) Guide for checking rotor end play

Disassemble the turbocharger from the engine, then check the rotor axial play and radial play. When disassembling the turbocharger, be sure to plug the oil inlet and outlet ports with taps, etc.

##### (1) Rotor axial play

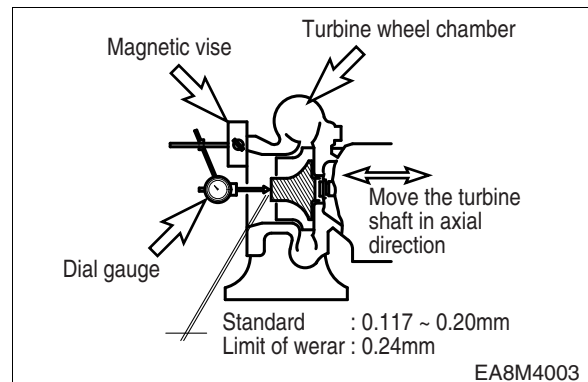

##### (2) Rotor radial play

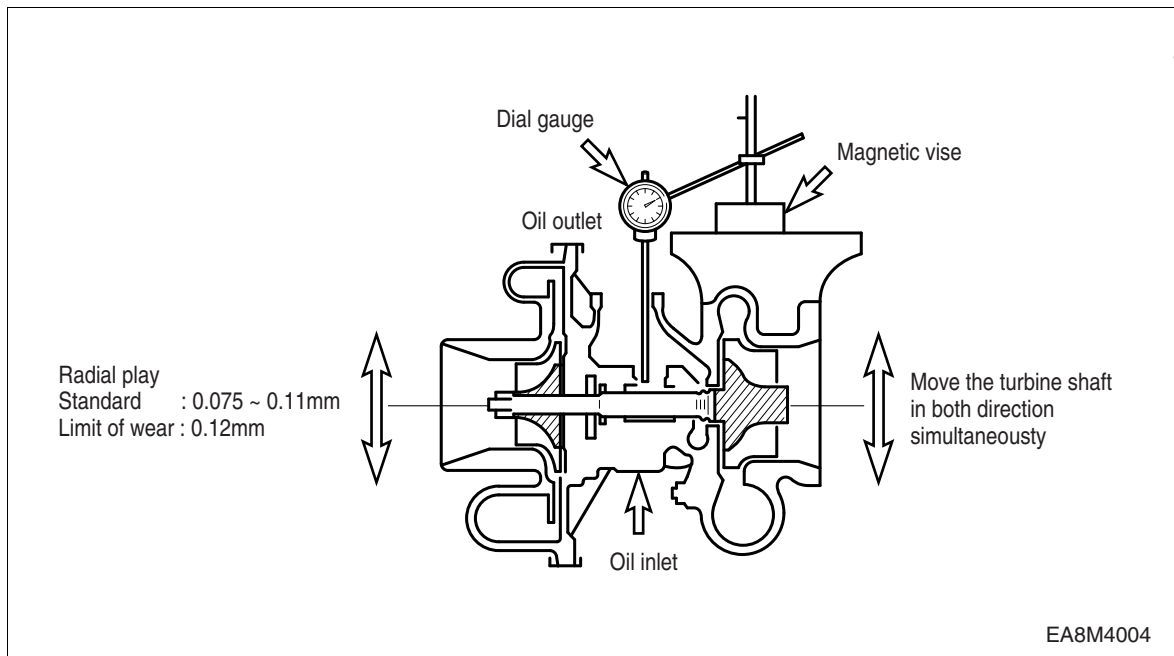

(3) If the measured axial and radial plays are beyond the limit of wear, replace or repair the turbocharger.

### **3) Guide for disassembling/cleaning and checking the turbocharger**

First, disassemble the turbocharger from the engine and clean/check it with the oil inlet and outlet plugged with tape and so on.

### **4) Precautions for reassembling the turbocharger onto the engine**

For reassembly of the turbocharger or handling it after reassembly operation, be sure to observe the following precautions:

Especially, exercise extreme care to prevent foreign matters from entering the inside of the turbocharger.

#### **(1) Lubricating system**

- Before reassembling the turbocharger onto the engine, inject new oil in the oil inlet port and lubricate the journal and thrust bearings by rotating them with hand.
- Clean not only the pipes installed between the engine and oil inlet port but also the oil outlet pipe and check them for damage or foreign matters.
- Assemble each joint on oil pipes securely to prevent oil leaks.

#### **(2) Intake system**

- Check the inside of the intake system for foreign matters.
- Assemble each joint on the intake duct and air cleaner securely to prevent air leaks.

#### **(3) Exhaust system**

- Check the inside of the exhaust system for foreign matters.
- Be sure to use heat resisting steel bolts and nuts. Do not interchange them with ordinary steel bolts and nuts when performing reassembly operation. Apply anti-seizure coating to the bolts and nuts.
- Assemble each joint on the exhaust pipes securely to prevent gas leaks.

### 5.3.7. Diagnostics and troubleshooting

Complaints	Possible causes	Corrections
1. Excessive black smoke	1) Air cleaner element clogged 2) Restrictions in air duct 3) Leakage at intake manifold 4) Turbocharger seized up and not rotating 5) Turbine blades and compressor blades coming in contact with each other or damaged 6) Exhaust piping deformed or clogged	Replace or clean Check and correct Check and correct Disassemble/repair or replace Disassemble/repair or replace Check and correct
2. Excessive white smoke	1) Oil leak into turbine and compressor 2) Worn or damaged seal ring due to excessive wear of bearing	Disassemble/repair or replace Disassemble/repair or replace
3. Low engine output	1) Gas leak at each part of exhaust system 2) Air cleaner element restricted 3) Turbocharger fouled or damaged 4) Leakage at discharge port on compressor side	Check and correct Replace or clean Disassemble/repair or replace Check and correct
4. Unusual sound or vibration	1) Rotor assembly coming in contact 2) Unbalanced rotation of rotor 3) Seized up 4) Each joint loosened	Disassemble/repair or replace Disassemble/repair or replace Disassemble/repair or replace Check and correct

## 5.4. Air intake system

### 5.4.1. Maintenance

**(only when engine is switched off)**

Empty the dust bowl (7) regularly. The bowl should never be filled more than halfway with dust.

On slipping off the two clamps (3), the dust bowl can be removed. Take off the cover (6) of the dust bowl and empty.

Be careful to assemble cover and bowl correctly.

There is a recess in the cover rim and a lug on the collector which should register. Where the filter is installed horizontally, watch for "top" mark on cleaner bowl.

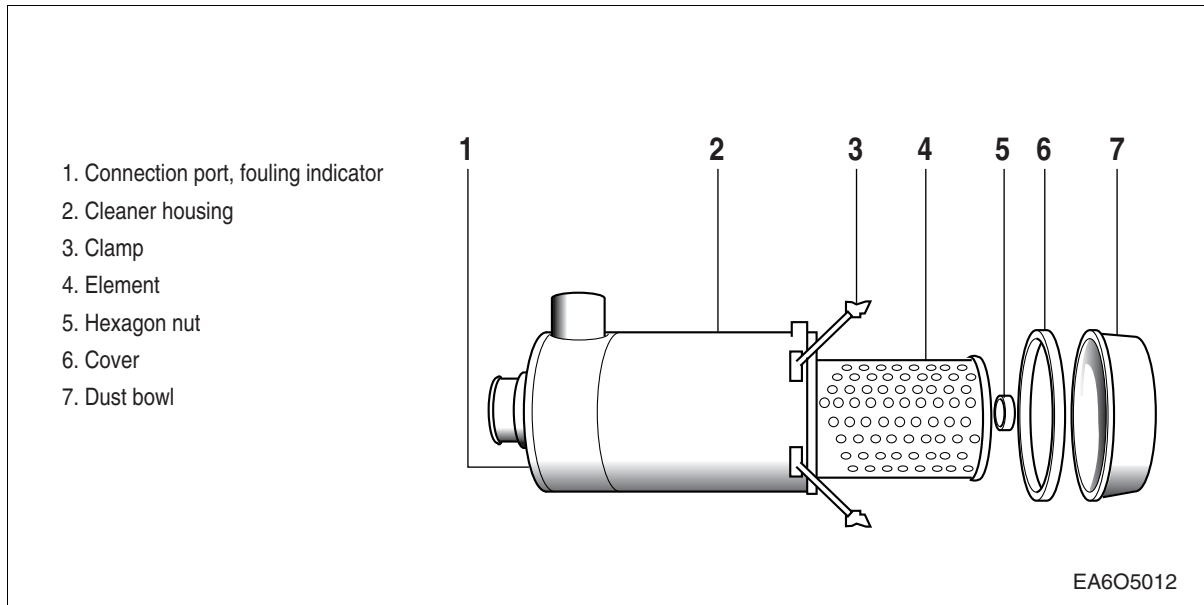

### 5.4.2. Changing filter element

- On removing the hexagon nut, take out the dirty cartridge and renew or clean.
- Wipe the cleaner housing with a damp cloth, in particular the sealing surface for the element.



**NOTE:**

**Do not allow dirt to get into the clean air end.**

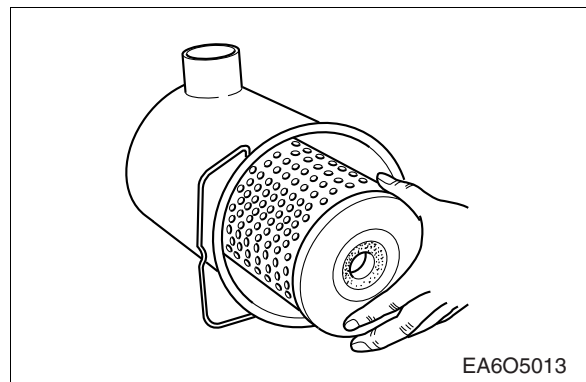

### 5.4.3. Cleaning filter elements

#### ● By compressed air (wear goggles)

- For the purpose, the air gun should be fitted with a nozzle extension which is bent 90° at the discharge end and which is long enough to reach down inside to the bottom of the element.
- Moving the air gun up and down, blow out the element from the inside (maximum 500 kPa - 5 bar) until no more dust comes out of the filter pleats.

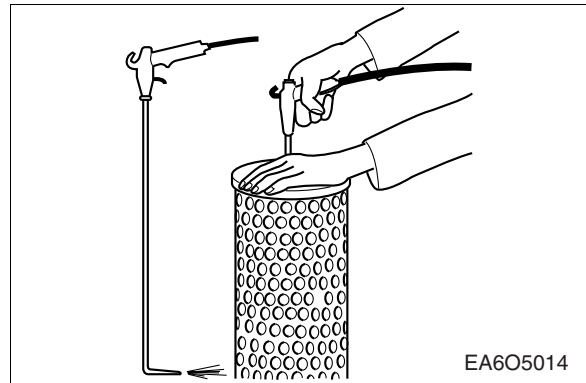

#### ● By washing

- Before washing, the element should be precleaned by means of compressed air, as described above.
- Then allow the element to soak in luke-warm washing solvent for 10 minutes, and then move it to and for in the solvent for about 5 minutes.
- Rinse thoroughly in clean water, shake out and allow drying at room temperature. The cartridge must be dry before it is reinstalled.
- Never use steam sprayers, petrol (gasoline), alkalis or hot liquids etc. to clean the filter elements.

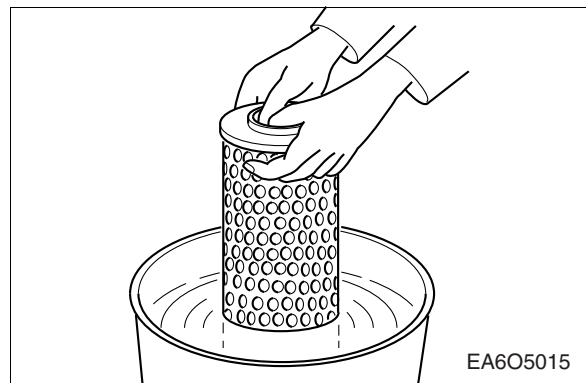

#### ● Knocking out dirt by hand

- In emergencies, when no compressed air or cleaning agent is available, it is possible to clean the filter cartridge provisionally by hitting the end disk of the cartridge with the ball of one's thumb.
- Under no circumstances should the element be hit with a hard object or knocked against a hard surface to loosen dirt deposits.

● **Checking the filter cartridge**

- Before reinstalling the cartridge, it must be checked for damage e.g. to the paper pleats and rubber gaskets, or for bulges and dents etc. in the metal jacket.
- Cracks and holes in the paper pleating can be established by inspecting the cartridge with a flashlight.
- Damaged cartridges should not be re-used under any circumstances. In cases of doubt, discard the cartridge and install a new one.

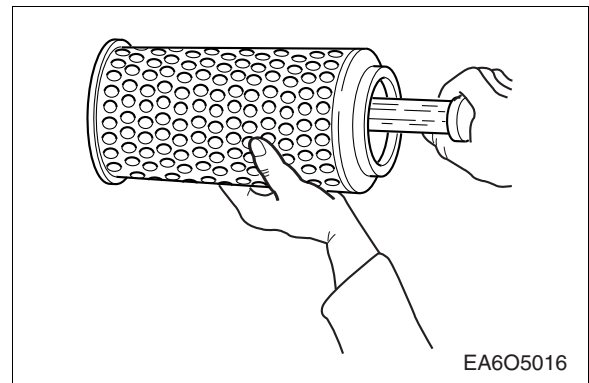

## Appendix

### ● Tightening torque for major parts

Major Parts		Screw	Strength	Tightening Torque
Cylinder Block	Main Bearing Cap Bolt	M16 x 1.5	12.9T	30 kgf.m
Oil Spray Nozzle		M14 x 1.5	SM45C	4.5 ±0.45 kgf.m
Flywheel Housing Bolt		M12 x 1.5	10.9T	11.2 ±1.6 kgf.m
Damper Pulley		M12 x 1.5	12.9T	13.4 ±1.3 kgf.m
Conrod Bearing Bolt		M14 x 1.5	12.9T	1st: 4 kgf.m ±0.2 2nd: 60°±3°
Flywheel Bolt		M14 x 1.5	10.9T	18.5 ±4.6 kgf.m
Head Bolt		M14 x 1.5	110 ~ 118 kg/mm <sup>2</sup>	6 ±0.6 kgf.m → 90° ±9° → 90° ±9° → 90° ±9° → 60° ±6°
Head Cover Bolt		M8 x 1.25	10.9T	3.1 ±0.3 kgf.m
EX Manifold Bolt		M10 x 1.5 M12 x 1.5	8.8T	4.4 ±0.44 kgf.m 8.0 ±0.8 kgf.m
Intake Manifold Bolt		M10 x 1.5	8.8T	4.4 ±0.44 kgf.m
Idle Gear Pin Bolt		M8 x 1.25	10.9T	3.1 ±0.3 kgf.m
Oil Pump		M10 x 1.5	8.8T	4.4 ±1.1 kgf.m
Oil Pan		M8 x 1.25	8.8T	2.2 ±0.22 kgf.m
Oil Cooler		M10 x 1.5	10.9T	6.2 ±1.55 kgf.m
Water Pump		M8 x 1.25	8.8T	2.2 ±0.55 kgf.m
Starter		M12 X 1.5	10.9T	11.2 ±2.8 kgf.m
Rocker Arm Bolt		Ⓐ M10 x 1.5 Ⓑ M12 X 1.5	Ⓐ 8.8T Ⓑ 8.8T	Ⓐ 4.4 ±0.44 kgf.m Ⓑ 8.0 ±0.8 kgf.m
Cooling Water Pipe		M8 x 1.25	8.8T	2.2 ±0.22 kgf.m
Alternator		M12 x 1.5	8.8T	8 ±2 kgf.m

### ● Tightening torque for plug screw

Diameter x pitch	M10x1.0	M12x1.5	M14x1.5	M16x1.5	M18x1.5	M22x1.5	M26x1.5	M30x1.5
Torque (kg.m)	5.0	5.0	8.0	8.0	10.0	12.0	12.0	15.0

### ● Tightening torque for hollow screw(4-hole)

Material	M8	M10	M12	M14	M16	M18	M22	M26	M30	M38
SM25C	-	1.6	2.5	3.5	4.5	5.5	9.0	13.0	18.0	30.0
* SUM22L	0.8	1.8	3.0	4.0	5.5	6.5	11.0	16.0	20.0	35.0
STS304	0.8	1.8	3.0	4.0	5.5	6.5	11.0	16.0	20.0	35.0

\* : Adopted in HD Hyundai Infracore engine

● **Standard bolt tightening torque table**

Refer to the following table for bolts other then described above

Diameter x pitch (mm)	Degree of strength										
	3.6	4.6	4.8	5.6	5.8	6.6	6.8	6.9	8.8	10.9	12.9
	(4A)	(4D)	(4S)	(5D)	(5S)	(6D)	(6S)	(6G)	(8G)	(10K)	(12K)
	Limit value for elasticity (kg/mm <sup>2</sup> )										
	20	24	32	30	40	36	48	54	64	90	108
Tightening torque (kg.m)											
M5	0.15	0.16	0.25	0.22	0.31	0.28	0.43	0.48	0.5	0.75	0.9
M6	0.28	0.30	0.45	0.4	0.55	0.47	0.77	0.85	0.9	1.25	1.5
M7	0.43	0.46	0.7	0.63	0.83	0.78	1.2	1.3	1.4	1.95	2.35
M8	0.7	0.75	1.1	1	1.4	1.25	1.9	2.1	2.2	3.1	3.8
M8x1	0.73	0.8	1.2	1.1	1.5	1.34	2.1	2.3	2.4	3.35	4.1
M10	1.36	1.4	2.2	1.9	2.7	2.35	3.7	4.2	4.4	6.2	7.4
M10x1	1.5	1.6	2.5	2.1	3.1	2.8	4.3	4.9	5	7	8.4
M12	2.4	2.5	3.7	3.3	4.7	4.2	6.3	7.2	7.5	10.5	12.5
M12x1.5	2.55	2.7	4	3.5	5	4.6	6.8	7.7	8	11.2	13.4
M14	3.7	3.9	6	5.2	7.5	7	10	11.5	12	17	20
M14x1.5	4.1	4.3	6.6	5.7	8.3	7.5	11.1	12.5	13	18.5	22
M16	5.6	6	9	8	11.5	10.5	17.9	18.5	18	26	31
M16x1.5	6.2	6.5	9.7	8.6	12.5	11.3	17	19.5	20	28	33
M18	7.8	8.3	12.5	11	16	14.5	21	24.2	25	36	43
M18x1.5	9.1	9.5	14.5	12.5	18.5	16.7	24.5	27.5	28	41	49
M20	11.5	12	18	16	22	19	31.5	35	36	51	60
M20x1.5	12.8	13.5	20.5	18	25	22.5	35	39.5	41	58	68
M22	15.5	16	24.5	21	30	26	42	46	49	67	75
M22x1.5	17	18.5	28	24	34	29	47	52	56	75	85
M24	20.5	21.5	33	27	40	34	55	58	63	82	92
M24x1.5	23	25	37	31	45	38	61	67	74	93	103

**Others :**

1. The above torque rating have been determined to 70% or so of the limit value for bolt elasticity.
2. Tension is calculated by multiplying tensile strength by cross section of thread.
3. Special screws should be tightened to 85% or so of the standard value.

For example, a screw coated with MoS<sub>2</sub> should be tightened to 60% or so of the standard value.

● Maintenance specification table

(Unit : mm)

Group	Part	Inspection Item	Stand value for assembly	Limit for use	Correction	Remark	
Engine body	Cylinder block & liner	Inside diameter of cylinder liner for wear	$\phi 111 \sim \phi 111.022$	$\phi 111.122$	Replace liner	Measure unworn portion beneath the rim of the upper side	
		Amount of liner projection	0.03 ~ 0.08	-	Need amount of projection without fail	Projection difference between adjacent liners : 0.15 ↓	
		The flatness of upper surface of cylinder block	0.05	-	Correct with a surface grinder	Referenced length : 200 mm	
		Hydraulic test for 1 minute (kg/cm <sup>2</sup> )	4	-	Replace if leaky		
	Cylinder head & valve	Valve seat depression	Intake	0 ~ 0.3	0.55	Replace valve seat	
			Exhaust	0 ~ 0.3	0.55		
		Cylinder head height	109.9 ~ 110.1	108.4	Replace cylinder head		
	Hydraulic test for 1 minute (kg/cm <sup>2</sup> )	4	-	Replace if leaky	Water temperature 70°C		
Major moving parts	Piston	Outer diameter of piston	$\phi 110.758 \sim \phi 110.772$		Replace liner	Measure at 13 mm away from lower surface of piston	
		Clearance between piston and liner	0.103 ~ 0.139	0.3	Replace one worn more		
		Width of piston ring grooves	Top ring	-	-	Replace piston if groove width is beyond specified value	
			2nd ring	3.06 ~ 3.08	-		
			Oil ring	4.04 ~ 4.06	-		
		Piston projection from cylinder block upper surface	0.005 ~ 0.5		Must exist	Measure unworn portion beneath the rim of the upper side	
	Permissible weight difference of each piston	±15 g	96 ↓	Replace piston			
	Piston ring	Piston ring gap	Top ring	0.40 ~ 0.60	1.5	Replace ring	Standard gauge inside diameter : $\phi 108$
			2nd ring	0.8 ~ 0.85	1.5		
			Oil ring	0.30 ~ 0.50	1.5		
		Piston ring side clearance	Top ring	-	-	Replace ring or piston	Limit for use is if for standard clearance
			2nd ring	0.07 ~ 0.102	0.15		
			Oil ring	0.05 ~ 0.085	0.15		
	Direction of ring gap	-	-	Cross Install by 120°			
Piston pin	Outer diameter of piston pin	$\phi 41.994 \sim \phi 42.000$	$\phi 41.94$	Replace piston pin			
	Clearance between piston pin and its bush	0.003 ~ 0.015	0.08	Replace one worn more			

(Unit : mm)

Group	Part	Inspection Item	Stand value for assembly	Limit for use	Correction	Remark
Major moving parts	Crank shaft	Radial run-out of journal and pin	-	0.01	Correct with a grinder	Measure in horizontal and vertical directions (against axial direction)
		Outside diameter of journal	$\phi 83.966 \sim \phi 83.988$	$\phi 83$	Use under sized bearings respectively (0.25,0.5,0.75,1.0)	
		Outside diameter of pin	$\phi 70.971 \sim \phi 70.990$	$\phi 70$		
		Ellipticity of journal and pin	0.008	0.025		
		Concentricity of journal and pin	0.01	0.03		
		Taper of journal and pin	0.02	0.03		
		Clearance between crankshaft and bearing	0.052 ~ 0.122	0.25	Replace bearings	Measure at crown part not parting line
		End play of crankshaft	0.15 ~ 0.325	0.5	Replace thrust bearing	
		Run-out of crankshaft	0.06	0.1↓	Adjust by a press if bended	Measure at No.4 bearing (No. 1 & 7 bearing supported)
		Balance of crankshaft(g.cm)	60↓	60 or less	Check dynamic balance	Measure at 400 rpm
		Torque value journal bearing cap bolt(kg.m)	30	-	Coat the bolt with engine oil	Clean out foreign objects on joining surface
		Crush height of journal bearing	0.08 ~ 0.110	-		Measure after tightening metal cap and releasing one stud
		Oil seal for wear (crankshaft rear)	-	-	Replace oil seal if oil leaking	
	Connecting rod	End play of con-rod	0.170 ~ 0.248	0.50	Replace con-rod	
		Clearance between con-rod bearing and crank pin	0.034 ~ 0.098	0.25	Replace bearing	
		Clearance between small end bush & piston pin	0.050 ~ 0.081	0.12		
		Crush height of con-rod bearing	0.04 ~ 0.07	-		Measure after installing the bearing and releasing one bolt
		Side clearance of big-end and small-end	-	0.50	Replace con-rod	
		Allowable weight difference per con-rods	30g↓	-		
		Torque value of con-rod bearing cap bolt (kg.m)	1st Step	4 ±0.2 kg.m	-	
	2nd Step		60° ±3°		Do not apply oil to the joint before bolting.	Clean out foreign objects on joining surface

(Unit : mm)

Group	Part	Inspection Item	Stand value for assembly	Limit for use	Correction	Remark	
Major moving parts	Cam shaft	Diameter of camshaft journal	$\phi 57.86 \sim \phi 57.88$	$\phi 57.52$			
		Clearance between camshaft and cam bush	0.12 ~ 0.17	0.24	Replace cam bush		
		End play of camshaft	0.28 ~ 0.43	0.6	Replace thrust washer		
		Run-out of camshaft	0.05	0.2	Correct or replace the camshaft		
	Timing gear	Clearance between idle shaft bush and idle shaft	0.025 ~ 0.091	0.15			
		End play of idle gear shaft	0.043 ~ 0.167	0.3	Replace thrust collar		
Back-lash between gears(cam, idle, crank and ignition timing)		0.16 ~ 0.28	0.35	Correct or replace gear			
Valve system	Valve	Diameter of intake valve stem	$\phi 8.950 \sim \phi 8.970$	$\phi 8.93$	Replace valve & valve guide	When replacing valve, replace valve guide alike	
		Diameter of exhaust valve stem	$\phi 8.935 \sim \phi 8.955$	$\phi 8.91$			
		Clearance between valve stem and valve guide	Intake	0.030 ~ 0.065	0.15	Replace valve or valve guide	Replace one worn more
			Exhaust	0.045 ~ 0.080	0.15		
		Thickness of valve head	Intake	2.7	Max. 1	Replace valve	
			Exhaust	2.2			
		Clearance between valve guide and valve spring seat	Intake	2.0	-		
			Exhaust	2.0	-		
		Clearance between valve guide and cylinder head installing hole		-0.039 ~ -0.010 (Press fit)			Spread oil over valve guide and press it into the hole
		Concentricity between valve stem and valve head		0.05			Without spring seat

(Unit : mm)

Group	Part	Inspection Item	Stand value for assembly	Limit for use	Correction	Remark		
Valve system	Valve	Intake valve spring	Free length (mm)	Approx. 64	-	Replace valve spring		
			Tension force(when pressed to 41 mm) kg	67 ~ 73	66.5			
			Square-ness(along free length direction)	1.5°	-			
		Exhaust valve spring	Inner	Free length (mm)	60	-		Replace valve spring
				Tension force(when pressed to 38 mm) kg	26.9 ~ 30.3	-		
				Squareness (along free length direction)	1.5°	-		
		Outer	Free length (mm)	71	-	Replace valve spring		
	Tension force(when pressed to 41 mm) kg		62.7 ~ 69.3	-				
	Squareness (along free length direction)		1.5°	-				
	Tappet	Valve clearance (at cold)	Intake	0.4 ±0.05	-	Adjust		
			Exhaust	0.4 ±0.05	-			
		Joining surface of valve stem and rocker arm bush		-	-	Grind or replace if severely pitted on tip of rocker arm and stem		
		Clearance between rocker arm shaft & rocker arm bush		0.040 ~ 0.113	0.2	Replace bush or shaft		
Diameter of rocker arm shaft for wear		φ 23.939 ~ φ 23.96	φ 23.75	Replace				
Run-out of push rod		-	0.3	Replace				
Clearance between tappet & tappet hole of cyl. block		0.035 ~ 0.077	0.15	Replace tappet				
Diameter of tappet		φ 19.944 ~ φ 19.965	-	Replace tappet				
Tappet face in contact with cam		-	-	Replace if severely worn or deformed				

(Unit : mm)

Group	Part	Inspection Item	Stand value for assembly	Limit for use	Correction	Remark	
Lubricating system	Oil pressure	Oil pressure(at normal speed) kg/cm <sup>2</sup>	4.8 or less	3.5	Check oil leakage and clearance between each part		
		Oil pressure(idling) kg/cm <sup>2</sup>	0.8 ~ 1.4	0.6	Use recommended oil		
	Oil temperature	Max. permissible oil temperature °C	-	105		Must not exceed this value	
		Permissible oil temperature in short time °C	-	120			
	Oil pump	Axial play of oil pump gear		0.055 ~ 0.105	-	Replace gear or cover	
		Clearance between gear shaft & oil pump cover hole		0.032 ~ 0.077	-		
		Clearance between drive gear shaft and cover hole		0.040 ~ 0.094	-	Replace bush or cover	
		Diameter of gear shaft		φ 16.950 ~ φ 16.968		Replace gear shaft	φ 17e7
		Diameter of driving gear bush		φ 28.000 ~ φ 28.033		Replace bush	φ 28e7
		Backlash	Between crank gear & idle gear	0.15 ~ 0.25	0.8	Adjust back-lash	
	Between oil pump drive gear & idle gear		0.15 ~ 0.25	0.8			
	Valve opening pressure	Oil pressure control valve (kg/cm <sup>2</sup> )		4.0 ~ 4.8	-	Replace valve	
		By-pass valve for filter element (kg/cm <sup>2</sup> )		1.8 ~ 2.3	-		
		By-pass valve for full oil filter (kg/cm <sup>2</sup> )		4.0 ~ 4.8	-		
		Relief valve for oil pump (kg/cm <sup>2</sup> )		8.5 ~ 11.5	-	Replace valve	
		Spray nozzle control valve (kg/cm <sup>2</sup> )		1.5 ~ 1.8	-		
	Oil filter	Damage of oil filter cartridge		-	-	Clean or replace	

(Unit : mm)

Group	Part	Inspection Item	Stand value for assembly	Limit for use	Correction	Remark
Cooling system	Water pump	Delivery volume l/min - Engine speed 2,700rpm - Water temp. 80°C - Pressure : 0.8 kg/cm <sup>2</sup>	280	-	Check the water passage	For any restrictions
		Clearance between impeller & housing	0.35	-	Replace if impeller & housing are damaged	
		Perpendicularity of pulley	0.3		Adjust by a bench press	
		Belt depression (with thumb) mm	Approx. 15	-	Adjust	
	Cooling water temp	Operating temperature(permissible temp.) °C	79 ~ 95	-	Must not exceed this value	
		Permissible temperature in a short time °C	-	105		
Ignition system	Spark plug	Gap of spark plug	0.39 ~ 0.40	-	Correct or replace	
Inspection at completion	Running-in the engine		-	-	Refer to supplement "running-in"	
	Cylinder pressure	Compression pressure of cylinder (kg/cm <sup>2</sup> )	16 or more	13 or more	Correct	at 200 rpm or more (20°C)
		Compression pressure difference of each cylinder	±10% or less against average		Correct	

