

# Operation & Maintenance Manual

**GENERATOR ENGINE**

**DX15**



**WARNING:** Breathing diesel engine exhaust exposes you to chemicals known to the State of California to cause cancer and birth defects or other reproductive harm.

- Always start and operate the engine in a well-ventilated area.
- If in an enclosed area, vent the exhaust to the outside.
- Do not modify or tamper with the exhaust system.
- Do not idle the engine except as necessary.

For more information go to [www.P65warnings.ca.gov/diesel](http://www.P65warnings.ca.gov/diesel).

# Preface

This Operation and Maintenance Manual provides information on engine management and maintenance techniques to customers and technicians of HD Hyundai Infracore's DX15 electronically controlled diesel engine for generators.

To provide the best engine to our customers, the DX15 electronically controlled diesel engine for generators is designed to satisfy all requirements for low noise, economic fuel consumption, high speed and durability with the latest technology and quality.

The engine must be operated and maintained both precisely and appropriately in order to maintain the engine in its optimal condition and performance over long periods of time. This Operation and Maintenance Manual contains detailed specifications, reference values, diagnostic techniques, part information and figures for easier and more accurate understanding, maintenance and troubleshooting.

Performing the service work recommended by HD Hyundai Infracore properly and in the correct order can ensure greater effectiveness of service techniques and protect the safety of workers. Hence, make sure to familiarize yourself with the contents of this Operation and Maintenance Manual thoroughly before handling the engine.

HD Hyundai Infracore strives to develop and invest continuously in order to ensure the best performance and quality as well as to enhance maintenance techniques. The design of our product may be changed without prior notice and HD Hyundai Infracore shall not be held liable for the failure of this manual to contain all the design changes made to improve the product.

We will continue striving tirelessly to satisfy the needs of customers and to provide customers with information on safe and convenient maintenance techniques.

Please do not hesitate to contact us regarding misprints or inquiries concerning the contents of this Operation and Maintenance Manual.

Thank you for purchasing a HD Hyundai Infracore engine. We hope that this Operation and Maintenance Manual will be useful.

2025. 07

950106-180001EN

**HD Hyundai Infracore**

- \* Items exempted from warranty coverage
  - Malfunctions resulting from failing to comply with the proper handling instructions, regular inspections, and machine storage techniques specified in the user manual
  - Malfunctions resulting from failing to have the machine repaired at a designated dealer or center, or resulting from the use of non-genuine parts
  - Malfunctions resulting from unauthorized modifications, changes, or external hardware
  - Malfunctions resulting from incorrect operation by the user, delayed repairs, accidents, and natural disasters
- \* The contents of this operation and maintenance manual are the exclusive property of HD Hyundai Infracore. Any unauthorized reproduction, printing and distribution thereof are strictly prohibited.



# Table of Contents

<b>1. Introduction .....</b>	<b>1</b>
General Information .....	3
Danger, Warning, Caution, and Notes .....	4
Engine Care .....	7
<b>2. Operation and Maintenance .....</b>	<b>9</b>
Starting and Stopping the Engine .....	11
Engine Break-In .....	12
Running the Engine in Winter .....	13
Engine Inspections and Maintenance .....	14
<b>3. Performance and Specifications .....</b>	<b>17</b>
Engine Specifications and Performance .....	19
Outside Drawing of the Engine .....	24
Engine Serial Number .....	27
<b>4. Regular Inspections .....</b>	<b>29</b>
General Information .....	31
Maintenance Schedule .....	32
Cautions for Using Biodiesel .....	33
Cooling System .....	34
Lubrication System .....	38
Fuel System .....	42
Intake/Exhaust System .....	44
Cylinder Block/Head .....	46
Other/Driving System .....	49
<b>5. General Engine Information .....</b>	<b>51</b>
Method of Indicating Units .....	53
Tightening Torque .....	54
Engine Disassembly .....	57
Engine Assembly .....	67
<b>6. Cooling System .....</b>	<b>85</b>
Overview and Specifications .....	87
Thermostat .....	89
Causes of Faults and Troubleshooting .....	90
Air Heater (Optional) .....	91
<b>7. Lubrication System .....</b>	<b>93</b>
Overview and Specifications .....	95

<b>8. Fuel System .....</b>	<b>97</b>
General Information .....	99
Fuel System Components .....	100
<b>9. Intake/Exhaust System .....</b>	<b>121</b>
General Information .....	123
Turbocharger .....	123
<b>10. Cylinder Block/Head .....</b>	<b>133</b>
General Information .....	135
Cylinder Block .....	136
Cylinder Head .....	137
Valves .....	139
Rocker Arms .....	142
Tappet and Pushrod .....	143
Camshaft .....	144
<b>11. Electrical System .....</b>	<b>147</b>
Electronic Components .....	149
Circuit Diagram .....	151
Switches and Sensors .....	161
Engine Control Unit (ECU) .....	169
TMS 3.0 (Option) .....	172
Starter Motor .....	177
Alternator .....	179
<b>12. Other/Driving System .....</b>	<b>181</b>
General Information .....	183
Crankshaft .....	184
Pistons .....	188
Injectors .....	191
Miscellaneous .....	192
<b>13. Installation Guidelines .....</b>	<b>195</b>
Fuel Lines .....	197

# 1. Introduction

General Information .....	3
General Information .....	3
Danger, Warning, Caution, and Notes .....	4
General Information .....	4
General Precautions .....	5
Cautions for Starting the Engine .....	5
Cautions for Inspections and Maintenance .....	5
General Information .....	6
Other Safety Instructions and Environmental Pollution.....	6
Use of Genuine Parts.....	7
Engine Care .....	7
Preventing Damage and Wear.....	7
Preventing Pollution .....	8
Handling Engine Oil .....	8
HVO (Hydro treated Vegetable Oil) .....	8
GTL (Gas To Liquids) .....	8



## General Information

### General Information

This Operation and Maintenance Manual provides the most efficient methods for engine maintenance as well as quick, efficient methods to determine the cause of engine faults to ensure that any actions taken by professionally certified maintenance technicians are performed in the most efficient and safest way possible. In the event that the engine is serviced by an untrained technician or in facilities which are not equipped with the specified tools and equipment, the operator and/or others around the engine may sustain life-threatening physical injuries and severe faults may occur in engine performance.

Regular inspections and maintenance are required to maintain long-term optimal engine conditions and performance.

In the event that a part must be replaced, only genuine parts as defined by the parts on the list (PARTS BOOK) should be used. Using non-genuine imitation parts or recycled parts may cause critical damage and faults in engine performance. HD Hyundai Infracore shall not be held liable for any damage or faults resulting from the use of such parts.

The maintenance methods stated in this Operation and Maintenance Manual are the most efficient and safest work procedures. Some work procedures require special tools. For questions about genuine parts and special tools, please contact us.

This Operation and Maintenance Manual includes 'Danger,' 'Warning' and 'Caution' items intended to reduce the risk of possible injuries during operation of the engine. Failing to heed this information may lead to severe faults in engine performance and operation, as well as severely injuring workers. Hence, make sure to heed the 'Danger,' 'Warning' and 'Caution' items. Please note that it is not possible for this Operation and Maintenance Manual to include information about every possible danger or unanticipated risk which may occur while handling and servicing the engine.

# 1. Introduction

## Danger, Warning, Caution, and Notes

### General Information

Instructions which require absolute compliance while performing the inspection, service and troubleshooting procedures provided in this Operation and Maintenance Manual are classified more specifically as 'Danger,' 'Warning' and 'Caution' items. In addition, **Note** is used to provide additional descriptions and information required for maintenance technicians to successfully operate our engines. Complying with the proper service methods and 'Danger,' 'Warning' and 'Caution' items recommended by HD Hyundai Infracore can both enhance the effectiveness of engine maintenance and prevent physical injuries to workers. However, not every possible danger can be anticipated.

### DANGER

**Make sure to comply with these instructions; failure to do so may result in life-threatening physical injuries to workers and/or people around the engine.**

### WARNING

**Make sure to comply with these instructions; failure to do so may result either in physical injuries to workers and/or people around the engine or severe environmental pollution.**

### CAUTION

**Make sure to comply with these instructions; failure to do so may result in severe faults in engine performance and operation.**

Note) Additional descriptions, information, and references are provided for ease of understanding.

Safety sign	Reference	Location
	Fan	Operation & Maintenance manual
	V-belt	
	Turbocharger	
	Exhaust manifold (Heat screen)	
	Emergency stop device	

### WARNING

- While running the engine, be careful not to touch the safety guard on the cooling fan. Otherwise, the spinning cooling fan may cause severe injury, such as severing fingers.
- While running the engine, be careful not to touch the safety guard on the V-belt. Otherwise, the spinning V-belt may cause severe injury, such as severing fingers.
- The V-belt safety guard is an optional item for customers. The V-belt safety guard must be installed in order to prevent accidents. In the event that the V-belt safety guard is not installed, do not approach the engine while it is running. HD Hyundai Infracore is not responsible for accidents or injuries which occur without the V-belt safety guard installed.
- Be careful not to touch the turbocharger components immediately after stopping the engine or while the engine is running. Otherwise, the heated turbocharger may cause severe injury. In the event that a heated turbocharger must be handled for the sake of maintenance or repairs, wait for the turbocharger to cool sufficiently before handling it.
- Be careful not to touch the exhaust manifold or heat shield components immediately after stopping the engine or while the engine is running. Otherwise, this may cause severe injury. The heat shield installed on the exhaust manifold becomes especially hot, so take care not to touch it.
- In the event that emergency engine maintenance must be performed, use the mechanism installed on the generator first. It may be difficult to operate the 'manual emergency stop device' installed on the fuel pump, and touching the exhaust manifold may cause severe injury. Hence, use the 'manual emergency stop device' after installing a separate auxiliary cable. HD Hyundai Infracore is not responsible for accidents or injuries which occur without a separate auxiliary cable installed.

## General Precautions

1. To use the engine safely and with optimal performance over long periods of time, engine operators must familiarize themselves with the contents of this Operation and Maintenance Manual and perform both daily and routine inspections.
2. We have divided the contents of this manual into causes of bodily injury, property damage, and causes of pollution. Make sure to comply with all instructions concerning the specified regulations and mounting locations.

---

### **WARNING**

---

**While starting the engine or during inspections and maintenance, if skin accidentally comes in contact with corrosive acid or fuel, you are burnt by hot oil, or fuel or antifreeze gets in your eyes, seek medical assistance immediately.**

---

## Cautions for Starting the Engine

1. Before starting the engine, make sure to read this Operation and Maintenance Manual carefully and familiarize yourself with the 'Danger,' 'Warning' and 'Caution' items. Please contact HD Hyundai Infracore if there is any uncertainty regarding the contents of this manual or if you have any questions.
2. For the sake of safety, attach a warning to the engine prohibiting anyone but workers from approaching the engine while it is in operation. Make sure to notify the engine operators that the safety of the engine room is their responsibility.
3. Only authorized personnel may start and operate the engine. Never allow an unauthorized person to handle the engine.
4. Do not approach rotating or moving parts while the engine is in operation.
5. Be careful not to touch or come in contact with the engine while it is running since it becomes hot during operation.
6. Exhaust gas is poisonous. Before starting the engine, ventilate the workspace sufficiently; when working in an enclosed space, check to ensure that the space is ventilated.

## Cautions for Inspections and Maintenance

1. Make sure to perform inspections and service work only with the engine stopped. If it is absolutely necessary to perform inspections or service work with the engine running, be careful of any possible accidents and scalding.
2. If performing inspections or service work while the engine is running cannot be avoided, do not get too close to any rotating parts.

---

### **DANGER**

---

**Severe injuries may occur if gloves or accessories such as necklaces, rings or watches are caught in rotating parts during service work while the engine is running.**

---

---

### **WARNING**

---

**Do not replace or disconnect any pipes or hoses (engine fuel circuit, engine oil circuit, coolant circuit and compressed air circuit, etc.) while the engine is running. Spurring fluid may cause physical injuries.**

---

3. When draining engine oil, make sure to prepare a container of sufficient size to ensure that engine oil does not overflow.
4. When replacing or refilling engine coolant, open the coolant cap after cooling the engine sufficiently.

---

### **WARNING**

---

**If the coolant cap is opened while the engine is still hot, hot coolant will spurt out and may cause burns. Open the coolant cap only after cooling the engine sufficiently.**

---

5. Fuel is highly flammable. Smoking or using an open flame near the engine may cause a fire.

---

### **WARNING**

---

**When fuel needs to be refilled, make sure to add fuel while the engine is stopped.**

---

6. Label and store coolant containers separately to avoid confusion with beverage containers. If coolant is ingested, seek medical assistance immediately.
7. Follow the instructions provided by the battery manufacturer when checking or handling batteries.

---

### **WARNING**

---

**Battery fluid is toxic, corrosive and explosive. Hence, it should be handled by trained technicians.**

---

# 1. Introduction

---

8. Only certified service technicians should service and handle the engine.
9. Use proper tools only according to their intended use. Using a worn wrench with a split tip may lead to injuries due to slipping of the tool while working.
10. When lifting the engine with a crane, never allow anyone to stand or pass beneath it. Make sure to check the surroundings and ensure that there is enough safe space to work before lifting the engine.
11. Before inspecting and replacing parts in electrical systems, disconnect the battery ground cable first. To prevent a short circuit, connect the battery ground cable only after all other work is complete.
12. Before performing arc welding, stop the engine, shut off the power source and disconnect the wire harness connected to the engine control unit (ECU).
13. Do not apply any form of electric or mechanical shock or perform welding on electrical systems or the engine control unit (ECU).
9. Make sure to clean removed parts in order to remove any foreign matter before inspecting or reassembling them. Use compressed air to clean out oil holes and other holes.
10. Before assembling parts, apply a thin layer of suitable oil or grease to rotating parts or parts requiring lubrication.
11. If necessary, use a designated adhesive when installing gaskets in order to prevent oil or coolant leakage.
12. Tighten bolts and nuts to their specified tightening torque.
13. After completing service work, perform a final inspection and test run to check whether all service work was performed correctly.

## Other Safety Instructions and Environmental Pollution

Make sure to comply with the following instructions during engine service work to protect the safety of workers and prevent environmental pollution.

### General Information

1. Working on the engine while it is hot may cause burns, so make sure to perform work on the engine only after it has cooled sufficiently.  
Before working on fuel lines, use a diagnostic device to check the common rail pressure and engine temperature first.
2. Disconnect the ground cable from the battery to prevent damage to wires and sensors resulting from short circuits.
3. Engine oil and coolant may damage painted surfaces, so label and store them separately in appropriate containers.
4. Store removed parts in a designated area to avoid damaging or contaminating them.
5. For the sake of efficient and safe service work, use the specified tools and special tools.
6. When replacing parts, make sure to replace them with genuine HD Hyundai Infracore parts. Using imitation or recycled parts may cause severe faults with an impact on engine performance.
7. During service work, replace all parts such as cotter pins, gaskets, O-rings, seal rings, oil seals and washers with new ones. Reusing parts may cause faults in the engine and hinder normal engine performance.
8. To reassemble parts after removing them, make sure to store them in groups in their order of disassembly. In particular, bolts and nuts have different strengths, shapes and tightening torques depending on their mounting locations, so make sure to organize and store them properly.
1. The workspace must have low humidity and be well-ventilated.
2. The workspace must be clean, well-organized and free of any open flames.
3. Smoking within the workspace is strictly prohibited.
4. Workers must wear work clothes, protective glasses and safety shoes.
5. Workers may not wear any accessories such as necklaces, rings, watches or earrings.
6. When the engine must be started, ventilate the area sufficiently to prevent carbon monoxide poisoning; then, start the engine in a well-ventilated area.
7. Working on the engine while it is hot may cause burns, so make sure to perform work on the engine only after it has cooled sufficiently.
8. During service work while the engine is running, avoid working on any rotating or moving parts.
9. Dispose of used oil according to the regulations of local public institutions.
10. Spilling or allowing engine oil or fuel to leak into the ground may cause severe environmental pollution of seas, rivers and groundwater.
11. Dispose of anticorrosive agents, antifreeze, filter elements, cartridges, etc. which cannot be diluted, as special waste.
12. Dispose of coolant and special waste according to the regulations of local public institutions.

---

## **WARNING**

---

Failing to comply with the regulations of local public institutions may result in legal sanctions for violating regulations on the disposal of environmental contaminants.

---

### **Use of Genuine Parts**

The engine is a mechanically balanced assembly comprising a large number of parts. Accordingly, regular maintenance and replacement of consumable parts are essential for preventing engine failure and maintaining long-term optimal performance.

We recommend using genuine HD Hyundai Infracore parts when replacing parts. Using imitation or recycled parts may cause severe engine faults and damage for which HD Hyundai Infracore shall not be held liable.

## **Engine Care**

### **Preventing Damage and Wear**

Using the engine for any purpose other than that for which it was designed may cause severe faults in the engine for which HD Hyundai Infracore shall not be held liable. For details regarding the intended uses and purposes of the engine, please contact our sales department. Do not adjust, convert or change the engine control unit (ECU) without the authorization of HD Hyundai Infracore.

When a problem occurs in the engine, locate the cause and resolve the issue immediately to prevent any severe faults.

We recommend using genuine HD Hyundai Infracore parts when replacing parts. Using imitation or recycled parts may cause severe engine faults and damage for which HD Hyundai Infracore shall not be held liable.

Make sure to maintain the engine according to the following instructions.

1. Only use clean fuel with the specified grade. Please use the fuel recommended in this Operation and Maintenance Manual.

---

## **CAUTION**

---

**Using imitation or unspecified fuel may cause severe faults in the engine.**

---

2. Do not operate the engine without lubricant or coolant. Use only the products (engine oil, coolant, anticorrosive agents, etc.) recommended by HD Hyundai Infracore.
3. Always keep the engine and its surroundings clean.
4. Make sure to use the fuel recommended in this Operation and Maintenance Manual.
5. Use the maintenance schedule to perform inspections and replacements at the specified intervals.
6. Do not stop the engine immediately while it is hot. Instead, idle it for at least 5 minutes so that the engine temperature drops sufficiently.

---

## **WARNING**

---

**If the radiator cap is opened to add or replace coolant while the engine is overheated, hot coolant will spurt out and may cause serious burns.**

---

7. Check the engine oil level on flat, level ground. Do not fill oil past the upper limit mark on the oil level gauge.

---

## **CAUTION**

---

**Add engine oil immediately if the engine oil level falls below the lower limit mark on the oil level gauge.**

---

# 1. Introduction

---

8. If gauges for the battery, oil pressure, coolant temperature, etc. are installed in the machine, always check whether the gauges indicate normal levels.
9. Do not operate the engine without coolant.

---

## CAUTION

**Use a mixture of antifreeze and coolant. Using regular water in winter causes coolant flow paths in the cylinder block to freeze, possibly leading to engine damage.**

---

---

## CAUTION

**Do not spray high-pressure water directly on the engine. It may damage engine parts, electronic parts, and wiring.**

---

### Preventing Pollution

Note the following instructions to prevent environmental pollution during engine maintenance.

1. Drain used oil and coolant, etc. into suitable containers.
2. Dispose of used oil and coolant according to the regulations of local public institutions.
3. Be especially careful to ensure that drained oil and coolant do not spill onto the ground or into drains. Otherwise, drinking water sources may be severely contaminated.
4. Set aside oil, filters, filter cartridges, etc. as environmental contaminants and handle and dispose of them according to the specified procedures.
5. Handle and dispose of antifreeze, coolant, and anticorrosive agents as hazardous waste.

### Handling Engine Oil

If engine oil comes into contact with skin repeatedly over long periods of time, the skin contracts and dries out, possibly leading to skin irritation. Engine oil contains harmful substances. Hence, make sure to comply with the following safety rules when handling engine oil.

1. Do not come into contact with used engine oil repeatedly over long periods of time.
2. Always wear work clothes and gloves.
3. If engine oil comes into contact with skin, use water and soap or hand cleaner to wash it off immediately.
4. Do not use gasoline, fuel, thinners, solvents, etc. to wipe skin.
5. Wipe off oil and put on protective skin cream.
6. Do not keep oily gloves or rags in pockets.

---

## WARNING

**Dispose of used oil according to the regulations of local public institutions. Engine oil can cause severe environmental pollution if it is spilled on the ground, in drains, sewers, rivers, or seas. Failing to dispose of engine oil properly according to disposal regulations is punishable by law.**

---

### HVO (Hydro treated Vegetable Oil)

HVO is a synthetic diesel which is manufactured through the hydrogenation of plants and animal fats.

To the user, HVO is reminiscent of diesel in accordance with EN590, apart from HVO having a somewhat lower density. HD Hyundai Infracore approves the use of up to 100% HVO for engines in accordance with the EU standard EN15940.

### GTL (Gas To Liquids)

GTL is a synthetic fuel that is often refined from natural gas. To the user, GTL is reminiscent of diesel in accordance with EN590, apart from GTL having a somewhat lower density and less odour.

HD Hyundai Infracore approves the use of up to 100% GTL in accordance with the EU standard EN15940.

## 2. Operation and Maintenance

Starting and Stopping the Engine .....	11
Preparing to Start.....	11
When Starting the Engine .....	11
Immediately after Starting the Engine.....	11
During Operation.....	11
When Stopping .....	11
Engine Break-In .....	12
General Information .....	12
Breaking in New Engines.....	12
Inspection Items.....	12
Operation after Break-In Period .....	12
Inspection after Starting the Engine.....	12
Engine Oil Pressure .....	13
Coolant Temperature .....	13
Engine Speed (rpm).....	13
Running the Engine in Winter .....	13
Prevention of Coolant Freezing .....	13
Preventing Engine Overcooling .....	13
Engine Oil .....	13
Running the Primary Fuel Filter (Oil-Water Separator) Heater .....	13
Engine Inspections and Maintenance .....	14
Checking Engine Parts after Prolonged Operation .....	14
Turbocharger Inspections and Maintenance.....	14
Intake System .....	15
Exhaust System .....	15
Lubrication System .....	15
Fuel System Inspections and Maintenance .....	15



### Starting and Stopping the Engine

#### Preparing to Start

Inspect the following before starting the engine for the first time after purchasing it.

1. Check the fuel, coolant and oil levels before starting the engine; add as necessary.
2. Check whether the engine oil level lies between the upper and lower limit lines on the oil level gauge. The upper and lower limit lines on the oil level gauge indicate the maximum and minimum engine oil levels.

---

#### CAUTION

---

**Do not fill engine oil past the upper limit line on the oil level gauge. Overfilling oil can damage the engine.**

---

3. When adding fuel, oil or coolant, take care not to allow foreign matter to enter the engine; store them in a clean place when not in use in order to prevent contamination. Use only fuel, oil, coolant, etc. recommended by HD Hyundai Infracore. Otherwise, severe engine faults may occur.

#### When Starting the Engine

Follow the instructions below when starting the engine.

1. For cold starts, start the engine after preheating it sufficiently with the glow plug.
2. If the engine is started abruptly, oil cannot reach the turbocharger as well as the various parts of the engine; this lack of lubrication can lead to abnormal wear or seizure of the bearings. Hence, before starting the engine, it is necessary to run it with the starter motor to check for a rise in hydraulic pressure (until the needle on the hydraulic pressure gauge installed in the machine moves or the pressure indicator comes on).
3. Oil flow in pipes worsens after the engine has been stopped for a prolonged period of time or in cold weather. Hence, after changing the oil, replacing the oil filter cartridge or parts of the lubrication system or leaving the engine stopped for an extended period of time or in cold weather, undo the oil pipe connection at the inlet of the turbocharger and run the starter motor until oil flows out of it. Once this step is complete, make sure to retighten the pipe connection and start the engine.

#### Immediately after Starting the Engine

1. After starting the engine, do not increase the engine rpm suddenly when the engine and turbocharger are not yet rotating smoothly. The engine may be overloaded, leading to seizure in parts not yet sufficiently lubricated by oil. Hence, idle the engine after starting it to enable enough oil to reach the turbocharger.
2. Oil, air and gas leakage reduces hydraulic pressure. Oil leakage in particular may cause bearings to seize. Hence, in the event of an oil, air or gas leak, check the leaking part, locate the cause and resolve the issue.

#### During Operation

1. If the oil pressure is excessively low, it can lead to abnormal wear or seizure of bearings; if it is excessively high, it can cause oil leaks.
2. Continuing to run the engine with abnormal noise or vibrations may cause severe damage to the engine. Hence, in the event of abnormal noise or vibrations, lower the engine rpm slowly; then, stop the engine and determine the cause.

#### When Stopping

Do not stop the engine abruptly after running it at a high rpm for an extended period of time. If heat transferred from the hot turbine blades reaches the bearings and causes oil to burn, it may lead to seizure of the metal bearing and rotating shaft. Hence, after operating the engine at a high rpm for a prolonged period of time, idle the engine sufficiently before stopping it.

## 2. Operation and Maintenance

---

### Engine Break-In

#### General Information

In order to provide only engines of the highest quality, HD Hyundai Infracore ensures that engines undergo a final acceptance test before releasing them from the factory. However, since the engines are not run for an extended period of time, they must complete a break-in procedure during the initial 50 hours of operation after being delivered. Proper engine break-in ensures long-term optimal engine performance.

#### Breaking in New Engines

As the bearings in a new engine are not sufficiently broken in initially, they tend to break easily due to overload or running at a high speed, thereby shortening the engine life as well. Hence, make sure to follow the instructions below during the initial 50 hours of operation after receiving the engine.

1. Before running the engine, make sure to warm it up sufficiently until the engine temperature is suitable for normal operating conditions.
2. Avoid running the engine at a high rpm under overloaded conditions or for a prolonged period of time.
3. Do not run the engine at a high speed without a load.
4. Do not start or stop the engine abruptly.
5. Do not exceed 70% of the maximum engine load.
6. Inspections, maintenance and service work must be performed by certified technicians at accredited service centers according to the applicable standards.

#### Inspection Items

Check and inspect the following during the break-in period of a new engine.

1. Check periodically whether the engine oil lies within the specified range between the upper and lower limit lines on the oil level gauge.

---

### CAUTION

---

**In the event that the oil level cannot be checked accurately on the oil level gauge, rotate the oil level gauge 180° and stick the guide tube back in the oil level gauge; then, remove it and check the oil level again.**

---

2. In the event that the oil warning lamp installed in the machine turns on or blinks, it means that the oil pressure is too low. Hence, check the oil level and refill if necessary. When refilling engine oil, do not exceed the upper limit line on the oil level gauge. If the oil level is normal, check related parts, such as the oil pressure sensor, oil pump and oil lines.

---

### CAUTION

---

**The oil pressure may increase and decrease along with the engine speed (rpm). In addition, cold oil generally indicates a higher oil pressure at certain engine speeds (rpm) than warm oil—a phenomenon which occurs even in normal engine operating conditions.**

---

3. Check the coolant temperature gauge installed in the machine and check whether coolant is circulating properly. If the coolant level in the auxiliary tank is too low, the needle on the coolant temperature gauge may vibrate.
4. Replace the engine oil and oil filter after the break-in period.

---

### CAUTION

---

**Replace the engine oil and oil filter with engine oil and a genuine part recommended by HD Hyundai Infracore.**

---

#### Operation after Break-In Period

When starting the engine in extremely cold regions, the engine must be warmed up slowly. Do not increase the engine rpm abruptly before the engine has been preheated sufficiently. Oil consumption is higher until the piston rings are seated properly and the engine is running normally. Hence, the engine oil level must be checked periodically during the initial 50 hours of the break-in period.

#### Inspection after Starting the Engine

While the engine is in operation, always check the pressure in the engine lubrication system with the engine oil pressure gauge installed in the machine. If low oil pressure is indicated on the engine oil pressure gauge, stop the engine immediately. In addition, make sure to check whether the charge warning indicator of the generator is turned off while the engine is in operation.

1. Connect the positive (+) and negative (-) battery terminals securely to ensure that they do not come loose. The sheath on battery connector cables should not be torn or ripped.
2. If the battery charge warning indicator blinks or turns on and the engine stops suddenly while driving, check the electrical system for malfunctions.
3. If an abnormal condition, such as an abnormal emission color or odor, occurs while driving, stop the engine, locate the cause, and correct the issue.

## 2. Operation and Maintenance

---

4. Check the state of the engine during operation using the warning indicators and gauges installed in the machine.

### Engine Oil Pressure

If the engine oil pressure is inconsistent while idling or the engine oil pressure does not reach the specified amount while driving at a high speed, stop the engine immediately, check the oil level and check the oil lines for leakage.

### Coolant Temperature

Operating the engine with an excessively low coolant temperature increases fuel consumption and wear of the cylinder liner, thereby shortening the engine life.

### Engine Speed (rpm)

In electronically controlled engines, the engine control unit (ECU) has a function which prevents the engine from running at engine speeds (rpm) exceeding the specified amount in order to protect the engine. A variety of functions—such as controlling fuel flow, delaying ignition time, and blocking fuel and ignition—are set by the memory in the engine control unit (ECU) and cannot be changed arbitrarily by the operator.

### Running the Engine in Winter

#### Prevention of Coolant Freezing

Using only water to add coolant without any antifreeze can cause corrosion inside the engine, reduce cooling efficiency, and cause engine freezing in winter. When operating the engine in a cold area for an extended period of time, make sure to completely drain coolant from the engine. Frozen coolant can cause critical damage to the engine. When adding and replacing coolant, make sure to use coolant mixed with the specified ratio of antifreeze. Antifreeze prevents coolant from freezing.

#### Preventing Engine Overcooling

If the engine is cooled below the normal operating temperature, thermal efficiency drops and fuel consumption and wear of the cylinder liner increase. Hence, make sure to keep the engine running within the normal operating temperature range. If the coolant temperature remains below the normal operating temperature range in spite of running the engine for a sufficient amount of time, check the thermostat or other parts related to the cooling system.

#### Engine Oil

If the engine oil viscosity increases due to cold temperatures in winter or in extremely cold regions, the engine rpm may be unstable after starting the engine. In order to prevent this phenomenon, make sure to replace the engine oil with engine oil intended for use in winter or extreme cold. When replacing engine oil, please use genuine oil recommended by HD Hyundai Infracore.

#### Running the Primary Fuel Filter (Oil-Water Separator) Heater

In winter and in cold temperatures, the paraffin in diesel forms a gel and blocks the surface of the cartridge in the primary fuel filter, resulting in restricted fuel flow. In such cases, engine start-up may be delayed/impossible, the engine rpm may be unstable after engine start-up, or the engine may turn off. To prevent this phenomenon, run the heater mounted on the primary fuel filter (oil-water separator) five minutes before starting the engine to remove the paraffin from inside the primary fuel filter and the paraffin gel entering continuously from the fuel tank.

Note) If the heater switch on the generator control panel is left on while the engine is turned off, the current consumption resulting from unnecessary operation of the fuel heater mounted on the primary fuel filter may cause the battery to discharge. Hence, if the generator control panel is not connected to a sufficient constant external charging power source, it is recommended to turn on the heater switch of the generator set five minutes before starting the engine.

## 2. Operation and Maintenance

---

### Engine Inspections and Maintenance

#### Checking Engine Parts after Prolonged Operation

The function of engine parts may be degraded by wear, corrosion, and thermal deterioration in engine parts and assemblies. In order to maintain optimal engine performance, check the engine after prolonged operation to enhance engine durability.

Even if the engine is operated normally, faults may occur in certain unpredictable and vulnerable parts as the engine is used over time. In such cases, it is difficult to maintain engine performance simply by repairing certain parts. In order to locate the causes of problems more accurately and maintain optimal engine performance, it is best to replace or repair all related parts as a whole.

In order to prevent engine malfunction in advance, performing replacements and inspections periodically enables the engine to be used safely for a longer period of time.

We recommend performing engine adjustments and preventive inspections in the spring after winter or cold temperatures have passed. In doing so, the engine can be used economically and without faults for extended periods of time.

As the following parts affect the engine output and performance, these parts should be checked and inspected periodically.

1. Components that can affect intake and exhaust
  - Air filter
  - Intercooler
  - Turbocharger, muffler
  - Misc.
2. Components that can affect lubrication and cooling performance
  - Air filter
  - Oil Filter
  - Antifreeze
  - Misc.
3. Components that can affect fuel injection
  - Fuel Tank
  - Primary fuel filter and cartridge
  - Secondary fuel filter and element
  - Common rail, high-pressure pump wiring fasteners

#### Turbocharger Inspections and Maintenance

As turbocharger performance has a significant impact on engine performance, it is important to perform periodic inspections and maintenance, as well as to comply with the specified instructions for handling the turbocharger.

#### Intake System

Be careful when handling the air filter of the intake system. In the case of wet-type air filters, filtration performance is degraded when the oil level drops below the specified amount, whereas oil may enter and contaminate the case if the oil level is higher than the specified amount. With dry-type air filters, the intake resistance must be low to enable air to be drawn in smoothly.

#### Exhaust System

With regard to the exhaust system, if exhaust gas leaks from the connection between the exhaust manifold and the turbocharger, the efficiency of the turbocharger drops, causing a corresponding reduction in engine power. In severe cases, related parts may seize up. Parts in the exhaust system and turbocharger are used at high temperatures. Hence, it is important to keep parts organized during service work to avoid confusing bolts and nuts, etc. with ones used in other parts of the engine.

#### Lubrication System

Inspection and replacement of the lubrication system should be performed according to the replacement schedule for oil and the oil filter. Overheated engine oil can affect not only the engine itself, but also the engine performance.

#### Fuel System Inspections and Maintenance

1. Fuel Tank
  - Sludge resulting from chemical reactions among foreign matter such as condensate and moisture, various acidic substances, and microbes which breed in such environments form continuously in the tank. Accordingly, make sure to remove contaminants and wash the tank periodically; otherwise, foreign matter may enter the high-pressure fuel injection system of the engine, causing critical damage such as wear, corrosion and clogging in the engine injection system, as well as excessive maintenance expenses.
    - Condensate: Occurs when moisture in the air condenses on the inner wall of the tank due to the temperature difference between the fuel and the air
    - Foreign matter: Constantly enters through the fuel container and the air ports on the tank
    - Microbes: Constantly enter through the air port on the tank
2. Primary fuel filter and cartridge (oil-water separator)
  - Make sure to use genuine parts, comply with the specified replacement intervals, and periodically remove moisture stored in the filter to prevent it from entering the high-pressure fuel injection system of the engine.

### 3. Secondary fuel filter and element

Make sure to use genuine parts, comply with the specified replacement intervals, and take care to prevent foreign matter from entering the high-pressure fuel injection system of the engine.

### 4. Normal state of common rail and high-pressure pump wiring fasteners

If the fasteners for the common rail pressure sensor (RPS) and high-pressure pump fuel metering unit (FMU) wiring on the engine are loose, wire movement during engine operation causes wear on the metal pins of the connectors attached to the sensor and metering unit. If the amount of wear increases and the contact between the metal pins of the connectors lifts occasionally while the engine is running, the ECU registers this as an open circuit, displays a fault code and restricts engine power; for the sake of safety, the high-pressure pump maintains the maximum amount of fuel delivery to the common rail without any control of the amount of fuel by the ECU; and in the common rail, the pressure adjustment valve opens and is permanently damaged due to excessive pressure, causing large amounts of fuel to be returned to the fuel tank. Make sure that the various wires remain connected firmly during engine delivery.

## 2. Operation and Maintenance

---

# 3. Performance and Specifications

- Engine Specifications and Performance ..... 19
  - Engine Specifications..... 19
  - Engine Power..... 23
- Outside Drawing of the Engine .....24
  - Structural Diagram..... 24
  - Left/Right Sectional View ..... 25
  - Top View ..... 26
- Engine Serial Number .....27
  - Engine Code and Production Number ..... 27
  - Numbers Stamped on the Engine..... 27



### 3. Performance and Specifications

#### Engine Specifications and Performance

#### Engine Specifications

Item	Specifications				Remarks
	Non-Tier				
	DP158CD	DP158CD-1	DP158CC	DP158CB	
General Information					
Engine type	Four-stroke, V-type, water-cooled, turbocharged and air-cooled				
Combustion chamber type	Direct injection				
Cylinder liner type	Wet liner				
Timing gear system	Gear driven type				
No. of piston rings	Two compression rings and one oil ring				
No. of cylinders	8				
Cylinder I.D.	128 mm (5.0394 in.)				
Cylinder stroke	147 mm (5.7874 in.)				
Total displacement	15,133 cc				
Compression ratio	14.8 : 1				
Compression pressure	35 bar (508 psi)				at 200 rpm
Engine dimensions (length x width x height)	1,713 x 1,417 x 1,684 mm (67.44 x 55.79 x 66.30 in.)				
Engine weight	1,000 kg (2,205 lb)				
Direction of rotation	Counterclockwise				When seen from flywheel
Firing order	1 - 5 - 7 - 2 - 6 - 3 - 4 - 8				
Cooling system					
Cooling method	Water-cooled forced circulation				
Coolant Capacity	27 L / 7.13 gal.				Inside the engine
Coolant pump type	Centrifugal (pulley type)				
Thermostat	Type	Wax pellet type			
	Opening temperature	71°C (160°F)			
	Full opening temp.	85°C (185°F)			
Coolant temperature sensor	Installed				
Lubrication System					
Lubrication method	Forced lubrication				
Oil pressure	Idle (bar)	Min. 1.0 bar (14.5 psi)			
	Rated (bar / psi)	Min. 3.0 bar (43.5 psi)			
Oil specifications	Oil Grade	API CI-4			
	SAE viscosity	SAE 10W40			
Oil capacity	Total	58 L (15.3 gal.)			
	Maximum	55 L (14.5 gal.)			
	Minimum	22 L (5.8 gal.)			

### 3. Performance and Specifications

Item	Specifications				Remarks
	Non-Tier				
	DP158CD	DP158CD-1	DP158CC	DP158CB	
Allowable tilt angle of oil pan	10° / 10° / 22.5° / 22.5°				Front/rear/left/ right
Oil pump type	External spur gear type				
Oil cooler type	Water-cooled layered plate				
Oil filter type	Cartridge				
Oil separator type	Impact (CCV)				
Hydraulic pressure indicator	Oil pressure sensor				
Fuel system					
Type of high-pressure fuel pump	Bosch CP3.4H+ (common rail system)				
Engine control type	ECU (Bosch, MD1CE 200)				
Fuel injection starting pressure	Controlled by ECU				
Injector nozzle type	Multi-hole type				
Fuel filter type	Cartridge				
Cylinder Block/Head					
Valves	Over head valve				
Operating pressure	Intake	0.4 (0.0157 in.) ±0.05 mm			
	Exhaust	0.7 (0.0276 in.) ±0.05 mm			
Electrical system					
Intake/exhaust system					
Starter motor	Type	Auxiliary rotation			
	Capacity	24.0 V, 7.0 kW			
Preheating system	Air heater (DC 22 V, 3.96 kW) x 1 EA				Built-in IC REGULATOR

### 3. Performance and Specifications

Item	Specifications				Remarks
	EPA Tier-2		EPA Tier-3		
	60Hz				
	DP158CDS	DP158CCS	DP158CBK	DP158CAK	
General Information					
Engine type	Four-stroke, V-type, water-cooled, turbocharged and air-cooled				
Combustion chamber type	Direct injection				
Cylinder liner type	Wet liner				
Timing gear system	Gear driven type				
No. of piston rings	Two compression rings and one oil ring				
No. of cylinders	8				
Cylinder I.D.	128 mm (5.0394 in.)				
Cylinder stroke	147 mm (5.7874 in.)				
Total displacement	15,133 cc				
Compression ratio	14.8 : 1				
Compression pressure	35 bar (508 psi)				at 200 rpm
Engine dimensions (length x width x height)	1,713 x 1,417 x 1,684 mm (67.44 x 55.79 x 66.30 in.)				
Engine weight	1,345 kg (2,965 lb)				
Direction of rotation	Counterclockwise				When seen from flywheel
Firing order	1 - 5 - 7 - 2 - 6 - 3 - 4 - 8				
Cooling system					
Cooling method	Water-cooled forced circulation				
Coolant Capacity	27 L / 7.13 gal.				Inside the engine
Coolant pump type	Centrifugal (pulley type)				
Thermostat	Type	Wax pellet type			
	Opening temperature	71°C (160°F)			
	Full opening temp.	85°C (185°F)			
Coolant temperature sensor	Installed				
Lubrication System					
Lubrication method	Forced lubrication				
Oil pressure	Idle (bar)	Min. 1.0 bar (14.5 psi)			
	Rated (bar / psi)	Min. 3.0 bar (43.5 psi)			
Oil specifications	Oil Grade	API CI-4			
	SAE viscosity	SAE 10W40			
Oil capacity	Total	58 L (15.3 gal.)			
	Maximum	55 L (14.5 gal.)			
	Minimum	22 L (5.8 gal.)			

### 3. Performance and Specifications

Item	Specifications				Remarks
	EPA Tier-2		EPA Tier-3		
	60Hz				
	DP158CDS	DP158CCS	DP158CBK	DP158CAK	
Allowable tilt angle of oil pan	10° / 10° / 22.5° / 22.5°				Front/rear/left/ right
Oil pump type	External spur gear type				
Oil cooler type	Water-cooled layered plate				
Oil filter type	Cartridge				
Oil separator type	Impact (CCV)				
Hydraulic pressure indicator	Oil pressure sensor				
Fuel system					
Type of high-pressure fuel pump	Bosch CP3.4H+ (common rail system)				
Engine control type	ECU (Bosch, MD1CE 200)				
Fuel injection starting pressure	Controlled by ECU				
Injector nozzle type	Multi-hole type				
Fuel filter type	Cartridge				
Cylinder Block/Head					
Valves	Over head valve				
Operating pressure	Intake	0.4 (0.0157 in.) ±0.05 mm			
	Exhaust	0.7 (0.0276 in.) ±0.05 mm			
Electrical system					
Intake/exhaust system					
Starter motor	Type	Auxiliary rotation			
	Capacity	24.0 V, 7.0 kW			
Preheating system	Air heater (DC 22 V, 3.96 kW) x 1 EA				Built-in IC REGULATOR

### 3. Performance and Specifications

#### Engine Power

Suffix	Sales Model	50Hz/1,500 rpm						60Hz/1,800 rpm						Remark
		Gross Engine Output (kWm/PS)			Net Engine Output (kWm/PS)			Gross Engine Output (kWm/PS)			Net Engine Output (kWm/PS)			
		Standby	Prime	COP	Standby	Prime	COP	Standby	Prime	COP	Standby	Prime	COP	
OOG00	DP158CD	612/832	556/756	389/529	595/809	539/732	372/506	662/900	609/828	426/579	635/863	582/791	399/542	Non-Tier
OOG01	DP158CD-1	580/788	527/716	369/501	563/765	510/693	352/478	-	-	-	-	-	-	
OOG02	DP158CC	542/737	493/670	345/469	525/713	476/647	328/446	618/840	562/764	393/534	591/803	535/727	366/497	
OOG03	DP158CB	503/684	457/621	320/435	486/660	440/598	303/412	560/761	509/692	356/484	533/724	482/655	329/447	
LBG00	DP158CDS	-	-	-	-	-	-	662/900	609/828	426/579	635/863	582/791	399/542	EPA Tier-2
LBG02	DP158CCS	-	-	-	-	-	-	618/840	562/764	393/534	591/803	535/727	366/497	
LCG03	DP158CBK	503/684	457/621	320/435	486/660	440/598	303/412	560/761	509/692	356/484	533/724	482/655	329/447	EPA Tier-3
LCG04	DP158CAK	459/624	417/567	292/397	442/601	400/544	275/374	522/709	475/645	333/453	495/673	448/609	306/416	

Note) Ratings Definitions

The power ratings of Emergency Standby and Prime are in accordance with ISO 8528.

Fuel Stop power in accordance with ISO 3046.

Electric power (kWe) must be considered cooling fan loss, alternator efficiency, altitude derating and ambient temperature.

STANDBY POWER RATING is applicable for supplying emergency power for the duration of the utility power outage. No overload capability is available for this rating. A standby rated engine should be sized for a maximum of an 80% average load factor and 200 hours of operation per year. This includes less than 25 hours per year at the Standby Power rating.

PRIME POWER RATING is available for an unlimited number of hours per year in variable load application. Variable load should not exceed a 70% average of the Prime Power rating during any operating period of 24 hours. The Total operating time at 100% Prime Power shall not exceed 500 hours per year. A 10% overload capability is available for a period of 1 hour within a 12 hour period of operation. Total operating time at the 10% overload power shall not exceed 25 hours per year.

### 3. Performance and Specifications

#### Outside Drawing of the Engine

Note) The images shown represent the standard model; they do not include all models.

#### Structural Diagram

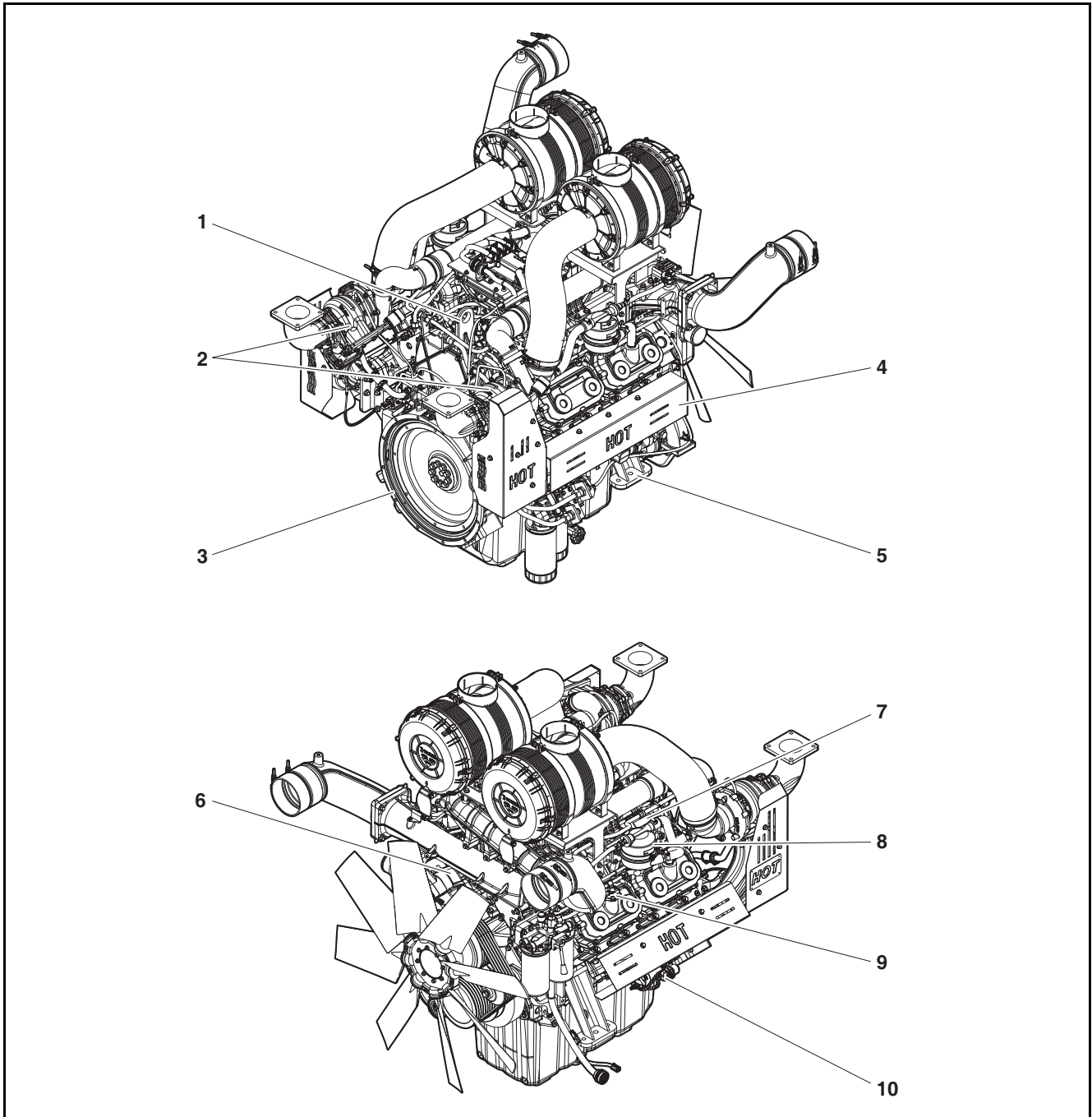

EDX15240001

- |                     |                     |                   |
|---------------------|---------------------|-------------------|
| 1. Lifting hook     | 5. Mounting bracket | 9. Oil filler cap |
| 2. Turbocharger     | 6. Coolant pump     | 10. Starter Motor |
| 3. Flywheel housing | 7. Intake manifold  |                   |
| 4. Exhaust manifold | 8. Breather         |                   |

### 3. Performance and Specifications

#### Left/Right Sectional View

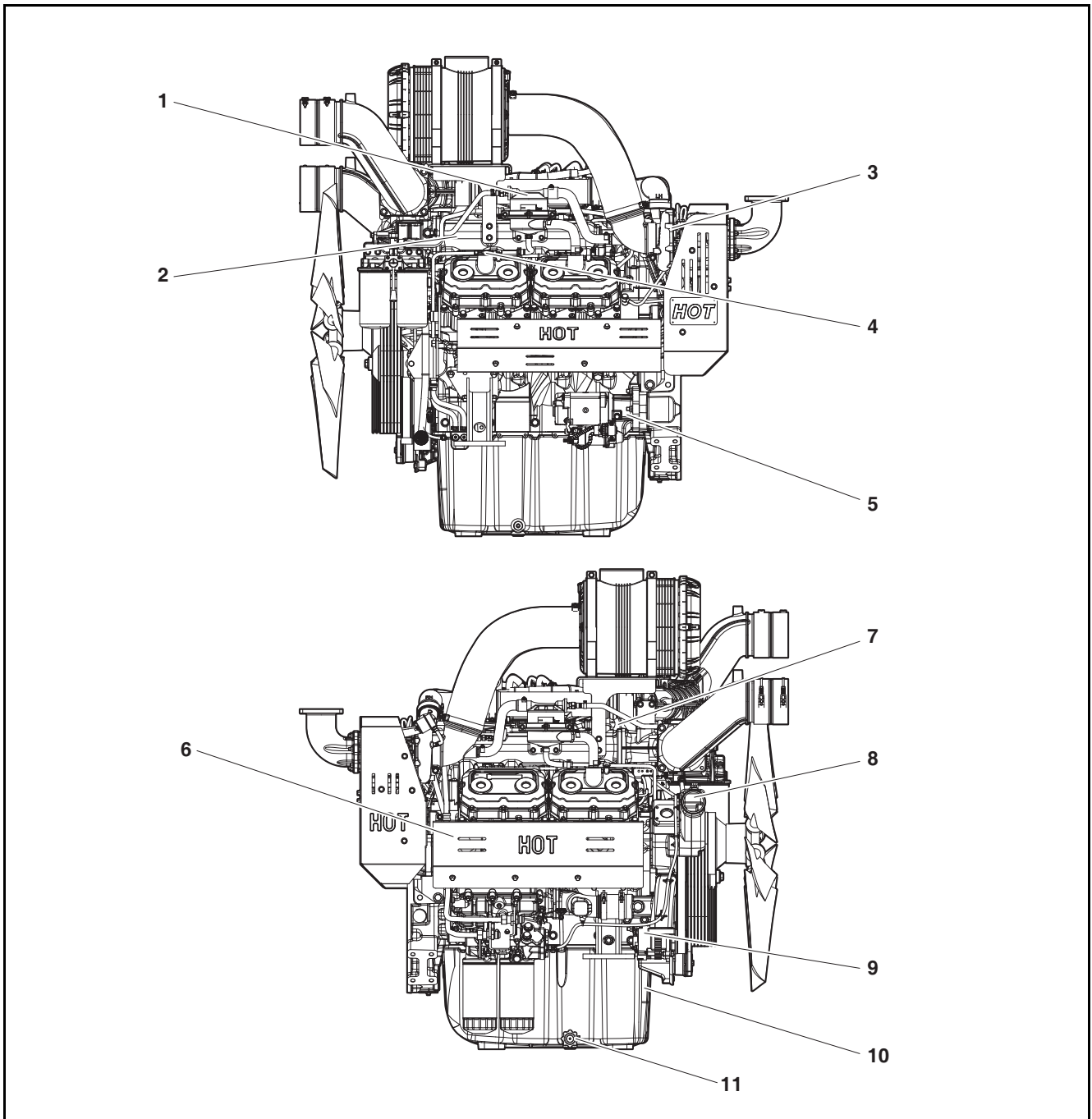

EDX15240002

- |                    |                                   |                |
|--------------------|-----------------------------------|----------------|
| 1. Breather        | 5. Starter Motor                  | 9. Oil pan     |
| 2. Intake manifold | 6. Heat shield & exhaust manifold | 10. Alternator |
| 3. Turbocharger    | 7. Lifting hook                   | 11. Drain plug |
| 4. Oil filler cap  | 8. Coolant pipe                   |                |

### 3. Performance and Specifications

---

#### Top View

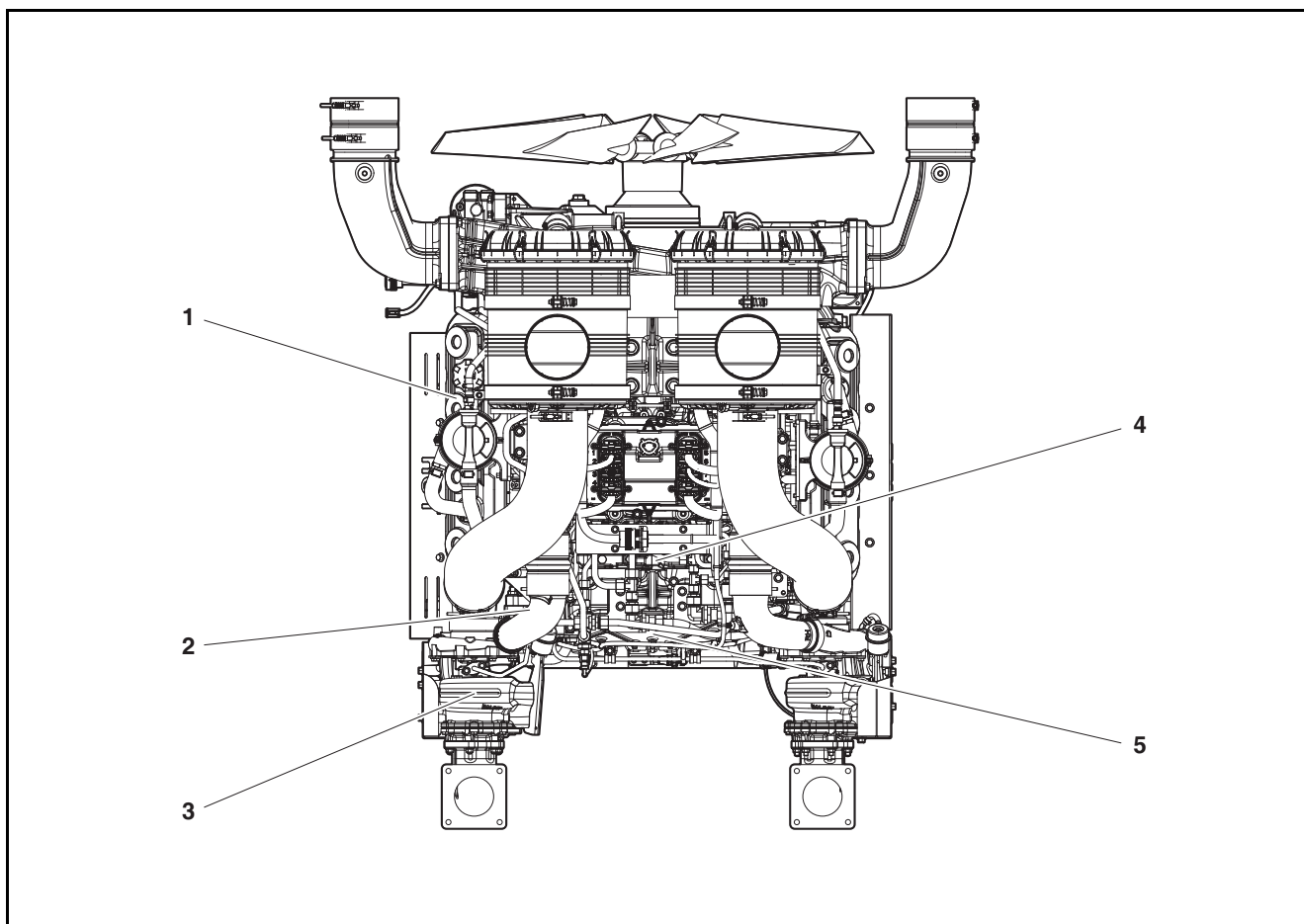

EDX15240003

- |                        |                  |                     |
|------------------------|------------------|---------------------|
| 1. Cylinder head cover | 3. Turbocharger  | 5. Timing gear case |
| 2. Air pipe            | 4. Injector pump |                     |

## 3. Performance and Specifications

### Engine Serial Number

#### Engine Code and Production Number

The engine code and production number are required for warranty claims and part orders.

#### Numbers Stamped on the Engine

- **Type 1**

(A) (B) (C)

- A. Engine model suffix (5 digits)
- B. Manufacturing year (1 digit)
- C. Series (5 digits)

- **Type 2**

(A) (B) (C) (D)

- A. Model name (4 - 7 digits)
- B. Year (1 digit)
- C. Series (5 digits)
- D. Engine model suffix (last 2 digits)

- **Type 3**

(A) (B) (C) (D) (E)

- A. Model name (5 digits)
- B. Power (3 digits)
- C. Year (1 digit)
- D. Series (5 digits)
- E. Engine model suffix (last 2 digits)

- **Type 4**

(A) (B) (C)

- A. New representative spec. (last 9 digits)
- B. Year (1 digit)
- C. Series (5 digits)

- **Type 5**

(A) (B) (C) (D)

- A. Model name (4 - 7 digits)
- B. Year (1 digit)
- C. Series (5 digits)
- D. New representative spec. (last 3 digits)

- **Type 6**

(A) (B) (C) (D) (E)

- A. Model name (5 digits)
- B. Power (3 digits)
- C. Year (1 digit)
- D. Series (5 digits)
- E. New representative spec. (last 3 digits)

### 3. Performance and Specifications

---

# 4. Regular Inspections

<b>General Information</b> .....	<b>31</b>
General Information .....	31
Daily Inspections.....	31
<b>Maintenance Schedule</b> .....	<b>32</b>
General Conditions .....	32
<b>Cautions for Using Biodiesel</b> .....	<b>33</b>
Allowable Fuel Under Warranty .....	33
Cautions for Using Biodiesel in Different Types of Generators.....	33
<b>Cooling System</b> .....	<b>34</b>
General Information .....	34
Coolant Specifications .....	34
Coolant Capacity.....	34
Coolant Inspections .....	34
Measuring the Coolant Concentration .....	35
Add Coolant .....	36
Replacing Coolant .....	36
Cleaning the Cooling Circuit .....	37
Coolant.....	37
<b>Lubrication System</b> .....	<b>38</b>
General Information .....	38
Engine Oil Specifications .....	39
Engine Oil Capacity .....	40
Checking Engine Oil .....	40
Adding Engine Oil .....	40
Adding Engine Oil .....	41
<b>Fuel System</b> .....	<b>42</b>
General Information .....	42
Fuel Specifications.....	42
Fuel filter .....	42
Bleeding Fuel Delivery Lines .....	42
Fuel Tank .....	42
Fuel Lines Connected to the Engine.....	42
Hand Priming Pump and Connecting Adapter.....	42
Primary Fuel Filter, Connecting Adapter, Fuel Heater, Service Tool .....	42
Engine Low-Pressure Fuel Lines .....	43

<b>Intake/Exhaust System</b> .....	<b>44</b>
General Information .....	44
Cleaning the Air Filter .....	44
Cleaning the Air Cleaner Element.....	45
Replacing the Air Cleaner Element.....	45
<b>Cylinder Block/Head</b> .....	<b>46</b>
Adjusting the Valve Clearance.....	46
Adjusting Sequence of Valve Clearance.....	47
Electrical System .....	48
Battery.....	48
<b>Other/Driving System</b> .....	<b>49</b>
Belt tension .....	49

### General Information

#### General Information

After purchasing the engine, the initial engine performance degrades over time due to aging of the various parts of the engine.

By performing regular inspections and part replacements according to the maintenance schedule recommended by HD Hyundai Infracore, the engine can be maintained in its optimal state for long periods of time and unanticipated accidents can be prevented.

It is the responsibility of the engine operator to operate and maintain the engine correctly. Inspections and replacements should be performed by certified technicians in service centers equipped with the specified tools and facilities. Make sure to follow the instructions below during inspections.

1. Perform inspections on flat, level ground.
2. Unless otherwise unavoidable, make sure to stop the engine before performing inspections.
3. Disconnect the negative (-) battery cable before performing inspections.
4. Perform inspections in a well-ventilated workspace.
5. When working underneath the engine, make sure to support the engine with chocks or lifters.

---

### DANGER

---

- **Before inspecting the engine after it has been running, make sure to wait until it has cooled off sufficiently. Otherwise, there is a risk of being burnt.**
  - **Running the engine in an enclosed space may cause poisoning due to exhaust gas. Make sure to perform inspections in a well-ventilated workspace.**
  - **Unless otherwise unavoidable, do not perform inspections underneath the engine.**
  - **Keep the engine away from open flames during inspections. Otherwise, there is a danger of a fire starting due to evaporative emissions from fuel, oil, or the battery.**
  - **In the event that the engine must be inspected while it is running, do not wear gloves or accessories such as necklaces, rings, or watches. Severe injuries may occur if anything is caught in rotating parts.**
  - **People with an artificial heart or artificial organs should not approach the engine while it is in operation. Artificial organs may malfunction due to the high-pressure current running through injectors and the engine control unit.**
- 

---

### CAUTION

---

- **Performing inspections incorrectly may lead to engine failure.**
  - **Cleaning an engine with liquids such as water or wax may cause electrical parts to malfunction.**
  - **Note that batteries, cables, and electrical wiring have current running through them.**
  - **Do not place heavy objects or apply excessive force or shock to fuel-related parts.**
  - **Before connecting battery terminals, make sure to check the polarity (positive '+' and negative '-') of the terminals. Connecting terminals with the polarity reversed may damage parts in electrical systems and cause a fire.**
- 

#### Daily Inspections

Daily inspections refer to inspections performed by the engine user every day before running the engine. These inspections must be performed for the safety of the engine and the operator.

The following inspection items are the minimum daily inspection items which must be checked.

1. Check whether the engine starts smoothly and whether the fuel, oil and coolant levels are normal.
2. Check the color of the exhaust gas and whether any toxic fumes are discharged from the engine.
3. Check for any abnormal noises after starting the engine.
4. Check for any oil or coolant leaks.

## 4. Regular Inspections

### Maintenance Schedule

#### General Conditions

Periodic inspections and replacements are absolutely necessary to ensure the optimum state of the engine during its service life and to prevent any unexpected engine failure. The maintenance schedule may differ depending on the operating conditions of the engine.

(o : Inspect and adjust, • : Replace)

Inspection	Daily	Inspection Interval (Hr)					Remarks
		50	250	500	750	1,000	
<b>Cooling System</b>							
Check for leaks (hoses, clamps)	o						
Check the coolant level	o						
Replacing Coolant							1 year/1,000 hours, whichever occurs first <sup>a</sup>
Check the exterior and tension of belts	o						
Clean the radiator						o	
<b>Lubrication System</b>							
Check for leaks	o						
Check the oil level gauge	o						
Change the lubricant		• Initial		•		•	1 year/500 hours, whichever occurs first
Replace the oil filter cartridge		• Initial		•		•	1 year/500 hours, whichever occurs first
<b>Intake and exhaust system</b>							
Check the intercooler (hoses, clamps) for leaks	o						
Check and replace the air cleaner element			o	•	o	•	
Clean the intercooler air fins				o		o	
Clean the turbocharger							Every 2,000 hours
<b>Fuel System</b>							
Remove residue from the fuel tank (before starting the engine)						o	
Inspect for leaks: Check the tightness/secureness of fuel lines	o						
Drain the water in the fuel tank/primary fuel filter (before starting the engine)	o						Or when the water warning lamp turns on
Replace the primary fuel filter cartridge				•		•	1 year/500 hours, whichever occurs first
Replace the secondary fuel filter element				•		•	(Every 6 months/250 hours, whichever occurs first, if bio-diesel is used)
Cleaning the nozzle tip of the injector							Every 1,500 hrs (EPA T2)
Check and adjust/repair the injector							Every 4,500 hrs (EPA T2)
<b>Adjust the engine</b>							
Check the condition of the exhaust gas	o						
Check the battery charge level	o						
Check the compression pressure							As necessary
Adjust the intake/exhaust valve clearance		o Initial				•	

a) The replacement intervals may be extended for the following specifications certified according to DIES-MT-0067 (prev. RES-C0198).

2 years/4,000 hours	LLC3	Donga Chemical	Ethylene Glycol (Low Phosphate Type)
	CROWN DS-36	Kukdong Jeyen	
	SKAF 1020	ZICOS	

### Cautions for Using Biodiesel

#### Allowable Fuel Under Warranty

1. Korea: Article 115 Schedule 33 "Ultra Low Sulfur Diesel" of the Clean Air Conservation Act
2. Europe: EN590:2013 AC:2014, EN16734:2016
3. North America: ASTM D975-15C Grade 1D or 2D
4. Japan: JIS K2204:2007 (lubricity  $\leq 520\mu\text{m}$ , FAME max. 5%)
5. China: GB252:2015 and GB19147:2013
6. India: IS 1460 2005 Amm. 10 BS III or BS IV
7. Brazil: ANP69/2014
8. Russia: GOST R32511-2013 (excluding Articles 3 and 4)
9. HVO

Characteristics and effects of 7% or higher biodiesel: If the amount of biodiesel in the fuel exceeds 7%, the oxidation stability decreases below that of ordinary diesel and the fuel reacts more easily with oxygen in the air, resulting in problems such as the formation of sludge and deposits, reduced lubrication, increased microbes, and excessive water in the fuel. If this foreign matter enters the engine, problems requiring high maintenance costs may occur, including premature clogging of the primary/secondary fuel filters, corrosion of fuel system components, and wear of components of the high-pressure injection system.

Hence, biodiesel must be stored only for less than six months from the date when it was manufactured and less than three months of being added to the generator set. Using fuel which has exceeded this storage period can cause critical damage to fuel system components, so make sure to follow these guidelines. In addition, if the fuel tank and fuel line components contain copper, lead, tin or zinc, the biodiesel oxidizes more quickly, resulting in engine damage due to fuel within a very short period of time or premature clogging of the primary/secondary fuel filters.

#### Cautions for Using Biodiesel in Different Types of Generators

1. ESP: Since fuel must be stored for long periods of time, it is forbidden to use more than 7% biodiesel, and in order to ensure stable engine operation in emergencies, we recommend using fuel without any biodiesel added. HD Hyundai Infracore is not liable for any problems in ESP generator engines resulting from the use of more than 7% biodiesel. If using biodiesel is absolutely necessary, make sure to check the quality and state of fuel periodically as per EN 15751 to ensure a minimum level of safety.
2. PRP/COP: Operating the engine with more than 7% biodiesel causes an increase in the pressure difference between the primary and secondary fuel filters and a gradual reduction in fuel flow due to the formation of sludge and deposits and an increase in microbes, so make sure to replace the filters every 250 hours — half of the 500-hour replacement interval normally recommended for filters. In addition, to minimize the formation of condensate and microbes in the fuel tank, when the engine is turned off, fill the fuel tank to the top, and when the engine is to be placed in storage and left unused for longer than one month, replace the biodiesel in the fuel tank with pure diesel and idle the engine in an unloaded state for 30 minutes or longer to flush out all of the biodiesel remaining in the engine fuel system before placing the engine in storage in order to minimize damage to fuel system components due to biodiesel.

< Primary/secondary fuel filter replacement intervals when more than 7% biodiesel is used >

Item	ESP	PRP	COP
Primary fuel filter	Do not use more than 7% biodiesel	Every 250 hrs. or 6 months, whichever occurs first	
Secondary fuel filter	Do not use more than 7% biodiesel	Every 250 hrs. or 6 months, whichever occurs first	

## 4. Regular Inspections

### Cooling System

#### General Information

Coolant plays an important role in the prevention of overheating and freezing of the engine. However, as the engine is used over time, the antifreeze and anticorrosive performance of coolant deteriorates. Make sure to check the condition of coolant during daily inspections and replace it periodically.

Engine coolant should have a mixture of 40% antifreeze. The water used in coolant should either be clean tap water or distilled water. Make sure to inspect coolant periodically to maintain the correct concentration of antifreeze.

#### CAUTION

**By maintaining the mixture ratio of coolant recommended by HD Hyundai Infracore, engine corrosion can be prevented effectively and the engine can be maintained in optimum condition for long periods of time. Using contaminated water or unspecified antifreeze or additives may cause critical faults in the cooling system.**

#### Coolant Specifications

- Amount of antifreeze in winter

Ambient temperature (°C)	Coolant (°C)	Antifreeze (%)
-10 or more	85	15
-10	80	20
-15	73	27
-20	67	33
-25	60	40
-30	56	44
-40	50	50

#### Coolant Capacity

Engine Model and Product Code	Coolant capacity (L)
DX15	Approx. 27 L

#### Coolant Inspections

#### DANGER

**If the radiator cap is opened to add or replace coolant while the engine is overheated, hot coolant will spurt out and may cause serious burns. In the event that the radiator cap must be opened, wrap it in a cloth and turn it slowly in two steps to release the steam pressure inside. Remove the radiator cap after all steam pressure inside has been released.**

1. Check the position of the auxiliary tank.
2. Check whether the engine and radiator are cool.
3. The coolant level should lie between the upper and lower limits indicated on the auxiliary tank.
4. Add coolant if necessary.
5. Open the radiator cap and check the condition of the coolant.

Measure the coolant concentration if the coolant is contaminated or if necessary. Replace the coolant if the concentration exceeds the specified coolant concentration.

## 4. Regular Inspections

### Measuring the Coolant Concentration

- Special tool

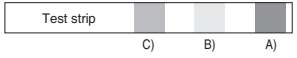
Figure	Part no. / name
	60.99901-0038 Coolant test strip

The coolant concentration can be measured as follows.

- When the engine coolant temperature is between 10 - 55°C (53.6 - 131°F), drain the coolant and fill a plastic cup halfway with it.

### CAUTION

**It is difficult to measure the precise concentration of coolant drained from the auxiliary tank. Make sure to collect coolant for the test by removing the coolant drain plug.**

- Soak the test strip in the collected coolant for 3 ~ 5 seconds and remove the strip from the coolant. Then, shake off any excess coolant.
- Wait approx. 45 seconds for the color of the test strip to change.

### CAUTION

**Do not wait longer than 75 seconds. The color of the test strip may change drastically after a long period of time.**

- Check the color of the test strip.

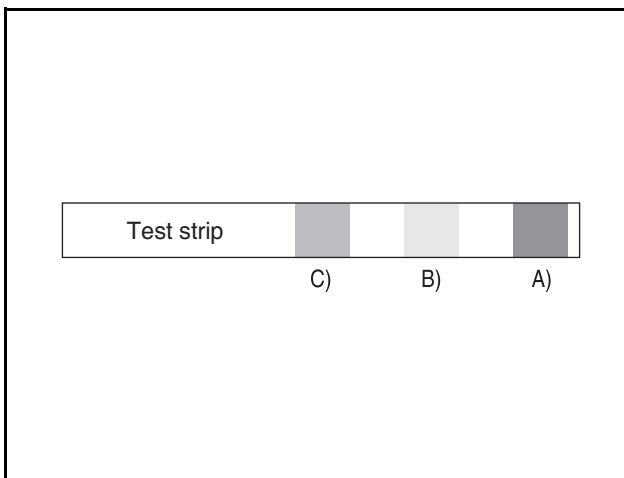

EDL022153A

- Compare the color of part (A) of the test strip with the color in the GLYCOL/FREEZEPOINT (End pad) section of the standard color table.

- Compare the color of part (B) of the test strip with the color in the MOLYBDATE (Middle pad) section of the standard color table.
- Compare the color of part (C) of the test strip with the color in the NITRITE section of the standard color table.
- Check the color of the test strip compared to the matching color in the standard color table.

		% GLYCOL / FREEZEPOINT (°C) (End Pad)								
		25%	33%	40%	50%	60%				
		-12°	-15°	-18°	-21°	-23°	-29°	-34°	-43°	-51°
		SCA Units per litre.								
Row	End Pad	0.0	0.4	0.7	0.9	1.0	1.1	1.3	1.5	
Row 6	TEST	0.0	0.4	0.6	0.7	0.9	0.9	1.1	1.3	
Row 5		0.0	0.4	0.5	0.5	0.6	0.7	1.0	1.2	
Row 4	SERVICE	0.0	0.3	0.4	0.4	0.6	0.7	0.9	1.1	
Row 3		0.0	0.2	0.3	0.4	0.5	0.6	0.8	1.0	
Row 2		0.0	0.2	0.2	0.2	0.4	0.5	0.7	0.9	
Row 1	PRE CHARGE	0.0	0.1	0.2	0.2	0.3	0.4	0.6	0.9	
Row 0		0.0	0.1	0.2	0.2	0.3	0.4	0.6	0.9	
	MOLYBDATE (MIDDLE PAD)	A	B	C	D	E	F	G	H	
	NITRITE									

EDL022154A

- Compare the changed color in part (A) of the pink end of the test strip with the GLYCOL/FREEZEPOINT (End pad) section of the standard color table on top of the storage container to determine the concentration. The concentration should be in the color range of 33 ~ 50%.
- The point at which the color of the MOLYBDATE (Middle pad) section in the standard color table corresponding to the middle (B) part of the test strip intersects with the color of NITRITE in the standard color table corresponding to part (C) of the test strip indicates the condition of the anticorrosive additive. The color must remain in the normal green range of 0.3 ~ 0.8.

### CAUTION

- If the color of the test strip does not match any color in the standard color table, look for an intermediate color in the standard color table. For instance, if the color of part (C) of the test strip falls between D and F in the NITRITE section of the standard color table, select section E.
- It is necessary to drain and add new coolant every year in order to prevent internal corrosion of the engine cooling system.

## 4. Regular Inspections

---

### Add Coolant

If the coolant level indicated on the auxiliary tank is below the lower limit, add coolant as follows.

1. Remove the cap on the auxiliary tank.
2. Add coolant until the coolant level is between the upper and lower limits on the auxiliary tank.
3. Install the cap on the auxiliary tank.

---

### CAUTION

**Be careful not to allow foreign matter to enter the engine while adding coolant.**

---

If there is no coolant in the auxiliary tank, add coolant as follows.

1. Remove the radiator cap while the engine and radiator are cold.
2. Add coolant up to the radiator inlet.
3. Start the engine; then, check the coolant level after circulating the coolant sufficiently. Add more coolant if necessary.
4. Install the radiator cap.
5. Remove the cap on the auxiliary tank.
6. Add coolant until the coolant level is between the upper and lower limits on the auxiliary tank.

---

### CAUTION

- **Do not open the radiator cap while the engine is overheated. Otherwise, hot coolant will spurt out and may cause severe burns. Open the radiator cap only after ensuring that the engine has cooled off sufficiently.**
  - **Label and store coolant containers separately to avoid confusion with beverage containers. If coolant is ingested, seek medical assistance immediately.**
- 

### Replacing Coolant

---

### CAUTION

**Be careful not to spill coolant on any belts or electrical components when replacing the coolant.**

---

1. Check whether the engine and radiator are cold.
2. Place a container in front of the coolant drain plug.
3. Remove the radiator cap.
4. Remove the coolant drain plug from the radiator and drain the coolant.
5. After draining the coolant, reinstall the coolant drain plug.
6. Drain the coolant from the auxiliary coolant tank and wash out the tank.
7. Fill the radiator inlet with water and install the radiator cap.

Note) After adding coolant slowly to allow air inside the radiator to be discharged, press on the hose connected to the radiator to drain the air inside more easily.

8. Run the engine until the cooling fan rotates 2 ~ 3 times. Then, increase the engine rpm 2 ~ 3 times once the engine has warmed up.
9. Stop the engine and wait until the engine cools off.
10. Remove the radiator drain plug and drain the water.
11. Repeat steps 1 ~ 8 until the water drained is clean.
12. Press on the hose connected to the radiator to drain the air in the radiator more easily; then, slowly fill the radiator inlet with coolant mixed to the specified ratio

Note) Make sure to use genuine antifreeze recommended by HD Hyundai Infracore.

---

### CAUTION

- **Do not use a mixture of antifreezes from different manufacturers.**
  - **Do not use a mixture of coolants with different concentrations.**
  - **Do not add an anti-rust agent which is not recommended by HD Hyundai Infracore.**
  - **A low coolant concentration may cause corrosion or freezing, whereas a high concentration may degrade cooling performance. Use a mixture of 40% antifreeze in coolant.**
- 

13. Idle the engine after starting it. Once the cooling fan is running and coolant has circulated, remove the radiator cap and add coolant through the inlet.
14. Add coolant until the cooling fan rotates 3 ~ 5 times.
15. Add coolant up to the upper limit on the auxiliary tank; then, install the radiator cap.

## 4. Regular Inspections

16. Idle the engine until the cooling fan rotates 2 ~ 3 times.
17. Stop the engine and wait until the engine and radiator cool off.
18. Check the coolant level in the auxiliary tank and add coolant repeatedly until the coolant level in the auxiliary tank remains consistently between the upper and lower limits.

Note) Check the coolant level in the auxiliary tank for at least 2 ~ 3 days after changing the coolant.

---

### CAUTION

---

**Check the coolant level in the auxiliary tank for at least 2 ~ 3 days after changing the coolant.**

---

---

### WARNING

---

**Dispose of used coolant according to the regulations of local public institutions. Coolant can cause severe environmental pollution if it is spilled on the ground, in drains, sewers, rivers, or seas. Failing to dispose of coolant properly according to disposal regulations is punishable by law.**

---

### Cleaning the Cooling Circuit

If the internal cooling circuit is corroded or contaminated, its cooling efficiency is degraded. Resistance in the cooling circuit can damage the mechanical seal of the coolant pump. Using improper antifreeze or anti-corrosive or using products without the correct properties can affect the cooling circuit negatively. If the coolant pump leaks or coolant is severely contaminated (cloudy or brown, gray or black according to its contamination level) after a short period of operating time (6 months), wash the cooling system as follows before removing the coolant pump. Wash the cooling system as follows before removing the coolant pump:

1. Drain the coolant.
2. To wash the cooling circuit quickly, remove the thermostat.
3. Fill the cooling circuit with a mixture of water and 1.5% cleanser (Henkel P3T5175).
4. Apply a load to the engine. Once the coolant temperature reaches 60°C (140°F), run the engine for approx. 15 minutes.
5. Drain the cleanser.
6. Repeat steps 3 and 4 above.
7. Fill the cooling circuit with hot water.

8. Idle the engine for 30 minutes and check the drain plugs and coolant lines for leakage. Add coolant as necessary.

---

### CAUTION

---

**Wash the cooling circuit periodically using cleanser.**

---

### Coolant

1. The coolant used in the engine must be soft water, not hard water.
2. You may dilute the engine coolant with 40% antifreeze and 3 to 5% anticorrosive (DCA4).
3. Inspect the density of the above-mentioned solutions and additives every 500 hours to maintain them at their proper levels.

Note) If you maintain the density of the antifreeze and anti-corrosive properly, you can effectively prevent corrosion and maintain stable engine quality.

Failing to maintain them may cause fatal damage to the water pump and cylinder liner so particular care is required.

4. The DX15 has a wet-type cylinder liner, so coolant must be managed even more carefully.
5. You can check the density of antifreeze and anticorrosive using a coolant test kit. (Fleetguard CC2602M)
6. How to use the coolant test kit
  - 1) When the temperature of the engine coolant is 10 ~ 55°C (50 ~ 131°F), remove the coolant drain plug and fill the plastic cup around halfway.

## 4. Regular Inspections

---

### Lubrication System

#### General Information

Engine oil serves to enhance engine performance and prolong engine life by lubricating, cooling, sealing, preventing corrosion and cleaning the inside of the engine. Running the generator continuously without sufficient engine oil may cause moving parts in the engine to seize up, leading to engine failure.

Check the engine oil level with an oil level gauge and add more engine oil if necessary. Check the oil level with the engine stopped. If the engine is running, stop the engine and measure the oil level after waiting 5 ~ 10 minutes to allow the engine oil to return to the oil pan. The oil level must lie between the upper and lower limits on the oil level gauge.

Engine oil must be changed regularly according to the maintenance schedule. Make sure to also replace the oil filter and cartridge when changing the engine oil.

## 4. Regular Inspections

### Engine Oil Specifications

Use the specified engine oil suited to the environment and conditions where the engine will be used.

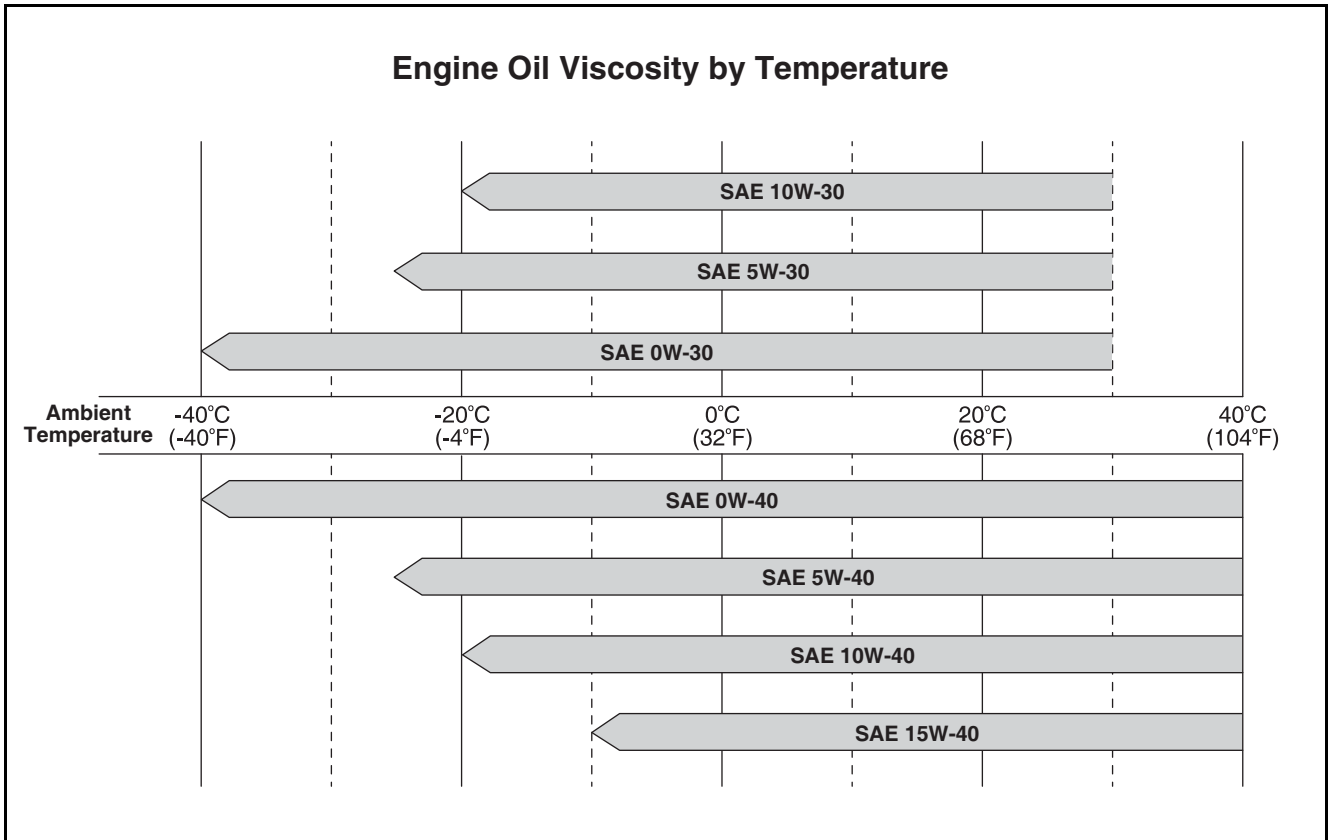

EDL06200023

The following engine oil specifications are recommended:

Engine Model	SAE Classification	Oil Grade
DX15	SAE 10W40	API CI 4 or higher

Note) Use genuine oil recommended by HD Hyundai Infracore.

## 4. Regular Inspections

### Engine Oil Capacity

Make sure to fill engine oil to the level recommended below.

Engine Model and Product Code	Engine Oil Capacity (L)		
	Inside the oil pan		Total <sup>a</sup>
	Maximum	Minimum	
DX15	55	22	58

- a. Including 3.0 L in the engine

### Checking Engine Oil

1. Move the engine to flat, level ground where the engine will remain horizontal.
2. After starting the engine, turn the engine off once it reaches a normal temperature.
3. Wait 5 ~ 10 minutes.
4. Pull out the oil level gauge.
5. Wipe off the indicator line on the oil level gauge with a clean cloth.

### **⚠ CAUTION**

**Wiping the engine oil gauge with a contaminated cloth causes foreign matter to enter the engine, leading to engine failure.**

6. Reinsert the oil level gauge.
7. Pull the oil level gauge out again and check the level and condition of the oil.

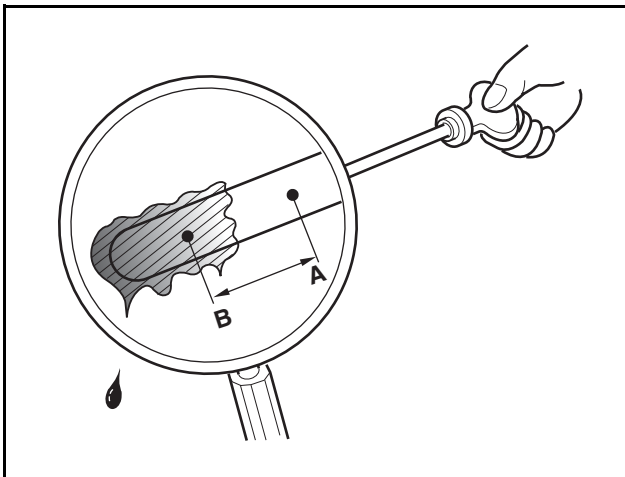

EDL022152A

- 1) Check whether engine oil is smeared between the upper limit (A) and lower limit (B) on the oil level gauge.

- 2) If engine oil is smeared below the lower limit (B) or is not smeared on the gauge at all, add engine oil.

### **⚠ CAUTION**

**Do not add engine oil past the upper limit mark on the oil level gauge. Overfilling oil can cause engine damage.**

- 3) Check the viscosity and condition of the engine oil; replace the oil if necessary.

### Adding Engine Oil

### **⚠ CAUTION**

**When removing the oil filler cap for work, be careful not to allow any foreign matter to enter the engine.**

1. Remove the oil filler cap on the top of the engine.
2. Add genuine oil recommended by HD Hyundai Infracore.
  - 1) Add the oil a small amount at a time.
  - 2) Wait 1 ~ 2 minutes and check the engine oil.
  - 3) Check whether engine oil is smeared between the upper and lower limits on the oil level gauge.
  - 4) Repeat until the engine oil reaches the proper level.

### **⚠ CAUTION**

- Be careful not to allow foreign matter to enter the engine while adding engine oil.
- Adding engine oil past the upper limit on the oil level gauge may cause engine faults. If engine oil is filled past the upper limit, the engine oil must be drained until the oil level lies between the upper and lower limits on the oil level gauge.
- Do not use unspecified engine oil additives.

3. Install the oil filler cap after adding engine oil.

## 4. Regular Inspections

### Adding Engine Oil

1. Drain the engine oil.

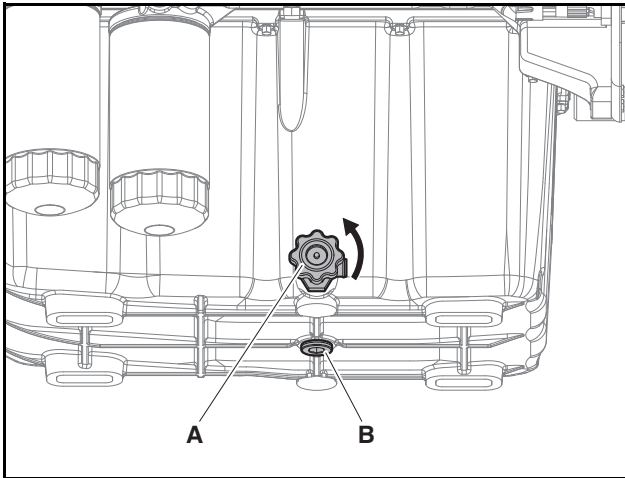

EDX15240080

- 1) Place a container for draining the engine oil under the engine.
  - 2) Turn the drain handle on the side counterclockwise to drain the engine oil.
  - 3) Drain the engine oil using either the drain handle (A) or the drain plug (B).
2. Replace the oil filter.

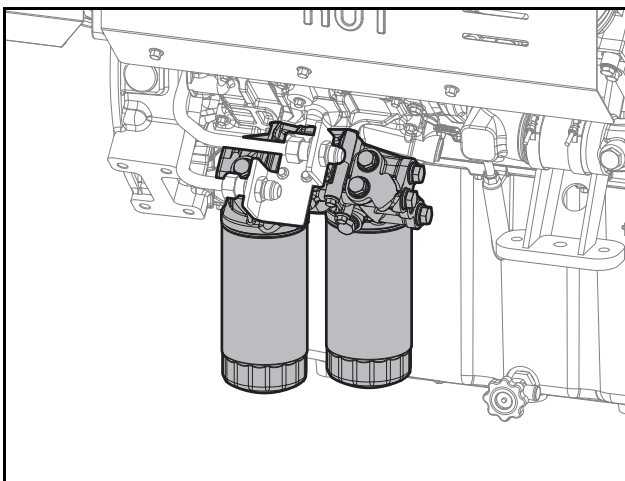

EDX15240025

- 1) Use a filter wrench to remove the oil filter.
- 2) Wipe off the head and cartridge contact surface of the oil filter thoroughly.
- 3) Make sure the oil filter cartridge is seated properly.
- 4) Apply a thin layer of oil to the O-ring on the cartridge.
- 5) Temporarily tighten the new oil filter by hand.

- 6) Use a filter wrench to finish tightening the oil filter.

### **⚠ CAUTION**

- When replacing the oil filter cartridge, make sure to use a new genuine HD Hyundai Infracore cartridge.
- The new oil filter must not contain any oil when it is installed. Do not fill the new oil filter with oil from the old oil filter.

3. Add engine oil.

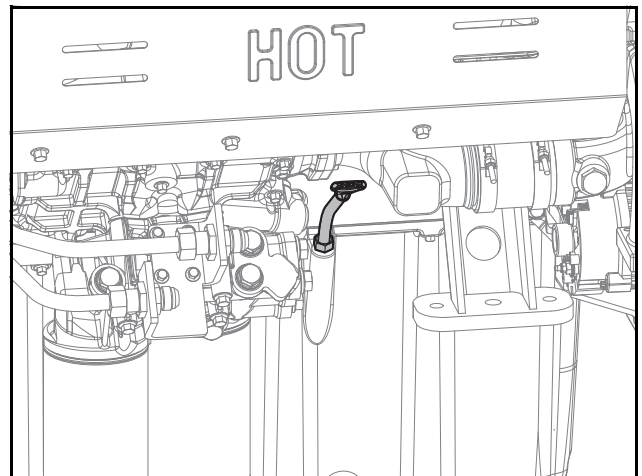

EDX15240026

- 1) Install the drain plug.
- 2) Add the specified amount of engine oil through the oil filler port.

### **⚠ CAUTION**

**While adding oil, be careful not to allow dust or foreign matter to enter the system.**

- 3) Check that the oil level is at the upper limit mark on the dipstick.
4. Once this is complete, perform a final inspection.
  - 1) Idle the engine for a few minutes to distribute oil throughout the lubrication circuit of the engine.
  - 2) Stop the engine and wait approx. 10 minutes.
  - 3) Check the oil level and add oil if necessary.

### **⚠ CAUTION**

**Adding engine oil past the upper limit on the oil level gauge may cause engine faults. If engine oil is filled past the upper limit, the engine oil must be drained until the oil level lies between the upper and lower limits on the oil level gauge.**

## 4. Regular Inspections

---

### Fuel System

#### General Information

Fuel quality is crucial for engine performance, engine life, and satisfying emissions standards. This engine is manufactured for use with standard fuel as specified by international petroleum-related laws and the Clean Air Conservation Act.

---

#### CAUTION

---

- Only use clean fuel with the specified grade. Using imitation or unspecified fuel may cause severe faults in the engine.
  - When fuel needs to be refilled, make sure to add fuel while the engine is stopped.
- 

#### Fuel Specifications

To maintain optimal engine performance as well as the durability and reliability of fuel system components, make sure to use fuel which satisfies the following fuel specifications.

- Korea: Article 115 Schedule 33 "Ultra Low Sulfur Diesel" of the Clean Air Conservation Act
- Europe: EN590:2013 AC:2014, EN16734:2016
- North America: ASTM D975-15C Grade 1D or 2D
- Japan: JIS K2204:2007 (lubricity  $\leq 520 \mu\text{m}$ , FAME Max. 5%)
- China: GB252:2015 and GB19147:2013
- India: IS 1460 2005 Amm. 10 BS III or BS IV
- Brazil: ANP69/2014
- Russia: GOST R32511-2013 (excluding Articles 3 and 4)

#### Fuel filter

The fuel filter consists of a primary and secondary filter; the primary filter serves to filter out water and large particles of foreign matter, while the secondary filter is used to filter out smaller particles of foreign matter.

---

#### CAUTION

---

- Failing to check the fuel filter periodically and drain the water in the fuel filter causes moisture to enter the engine fuel system, leading to severe faults in the fuel injection pump, fuel injection pipe, common rail, and injectors. In addition, the performance of the fuel filter may be degraded or the filter may be damaged.
  - When draining water from the fuel filter, fuel may be drained as well. Fuel is a highly flammable substance. Hence, smoking or using an open flame near the engine may cause a fire.
  - Only use clean fuel with the specified grade. Using imitation or unspecified fuel may cause water to accumulate in the fuel filter.
  - If water is not drained from the fuel filter when the fuel filter warning light is turned on, moisture may enter the fuel system and cause the engine to turn off.
  - New fuel filters must not contain any fuel when they are installed. Do not fill a new fuel filter with fuel from an old fuel filter or fuel in the fuel tank.
- 

#### Bleeding Fuel Delivery Lines

To bleed the air in the fuel line, unscrew the hollow screw on the fuel delivery pipe on top of the engine's high-pressure pump mounting fixture; then, use a hand priming pump to remove the air in the fuel line.

#### Fuel Tank

The fuel tank must be able to store fuel cleanly and safely and must be structured so as not to affect the components of the engine injection system.

#### Fuel Lines Connected to the Engine

Since the fuel lines connecting the engine and the fuel tank must be flexible enough to withstand vibrations while the engine is running, it is recommended to use hoses.

#### Hand Priming Pump and Connecting Adapter

A hand priming pump and two piping connecting adapters are provided as separate accessories along with the engine.

#### Primary Fuel Filter, Connecting Adapter, Fuel Heater, Service Tool

A primary fuel filter, two piping connecting adapters, fuel heaters, and a service tool are provided as separate accessories along with the engine.

### Engine Low-Pressure Fuel Lines

All low-pressure fuel lines are made of metal and have couplings which are shaped to fit the lines in order to maintain an airtight seal. When reused after repeated removal and reinstallation, the lines lose their airtightness and may cause fuel leaks, so make sure to replace the lines with new ones when they are removed. In the event that running the engine with a reused part is unavoidable, check for leaks periodically until the part can be replaced with a new one and make sure to replace the part as soon as possible. When installing parts, tighten the union nuts and hollow screws to the specified tightening torque and make sure to hold the opposing parts in place with a tool while tightening parts to ensure that the tightening torque is applied only to the coupling joint.

When the engine is running, all fuel lines must remain secured firmly in the positions where they were installed upon release from the factory. Running the engine with a missing or loose fastener produces vibrations which may damage the fuel lines, so always make sure that parts are secured in their proper positions.

## 4. Regular Inspections

### Intake/Exhaust System

#### General Information

The air filter serves to supply the engine with clean air by filtering out dust and foreign matter contained in atmospheric air. Replace the air cleaner whenever the element is either deformed or damaged, or when the air cleaner is cracked. The element must be checked and replaced regularly at the designated intervals.

- Check the air cleaner element: Every 250 hours
- Replace the air cleaner element: Every 500 hours

#### CAUTION

- Do not run the engine without an air filter.
- Only use specified air filters. Using an imitation or unspecified air filter may cause severe faults in the engine.
- If foreign matter enters the engine, it may cause wear inside the engine.
- Be careful not to damage related electrical parts or to allow foreign matter to enter the engine while replacing the air filter.
- Replace the air filter immediately if it is damaged.
- Be careful not to allow dust to enter the engine while installing the air filter.
- If the air cleaner element is deformed, damaged or cracked, replace it with a new one.
- Clean and replace the element at regular intervals.

#### Cleaning the Air Filter

1. Clean the air filter.
- 1) Empty the dust canister periodically.

#### CAUTION

**Do not allow the dust canister to fill more than halfway with dust.**

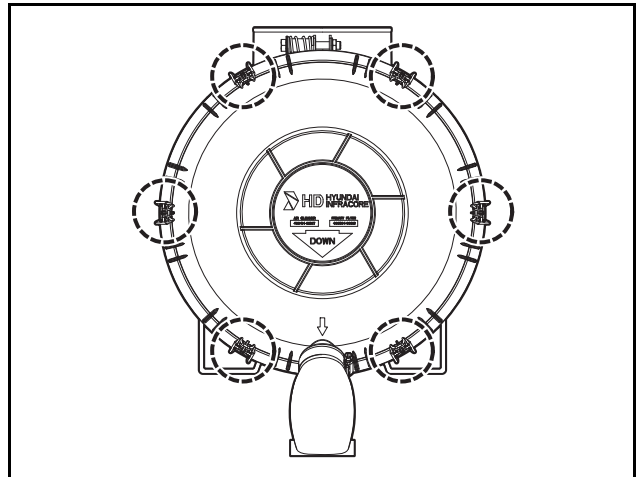

EDX15240108

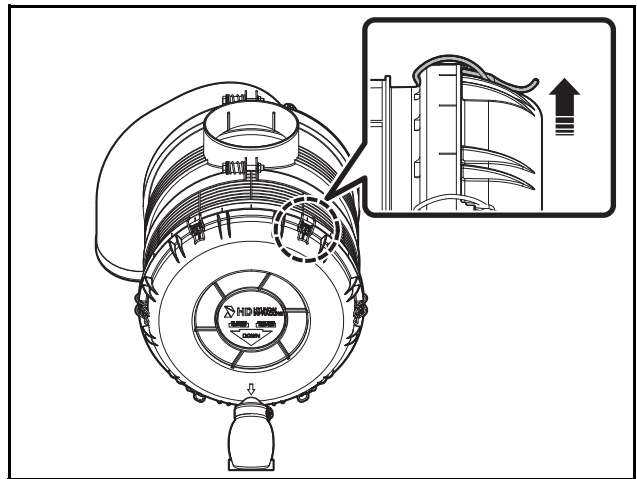

EDX15240109

- 2) Disassembled by loosening the 6 fixing clips.
- 3) Remove the dust canister cover and empty the canister.
- 4) Install the cover and dust canister correctly and with care.
- 5) Align the positions and fixed with 6 clips.

## 4. Regular Inspections

### Cleaning the Air Cleaner Element

Clean the air filter element using whichever of the following three methods is most suited to the work environment.

1. Use compressed air to clean the air filter element.

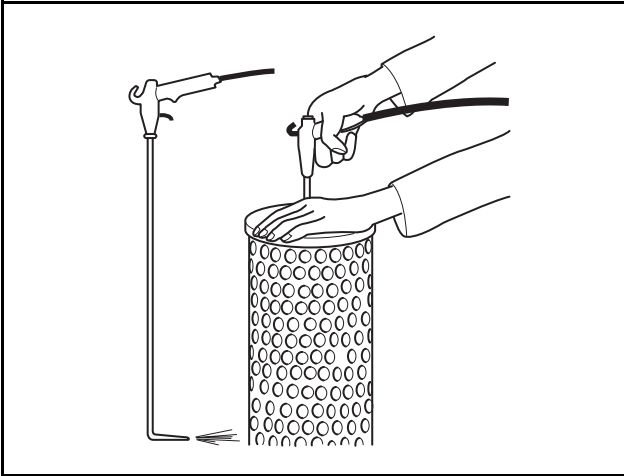

EDL022155A

- 1) Use an air gun to clean the element thoroughly all the way to the bottom. Compressed air should be shot at a 90° angle to the bottom of the element.
- 2) Move the air gun up and down along the element to blow compressed air from the inside toward the outside until dust is no longer blown out.
- 3) The pressure of compressed air should not exceed 5 bar / 72.5 psi.

### DANGER

**Make sure to put on protective glasses before performing this task. Otherwise, dust or foreign matter from the element may enter your eyes and cause injuries.**

### Replacing the Air Cleaner Element

1. Replace the air cleaner element.

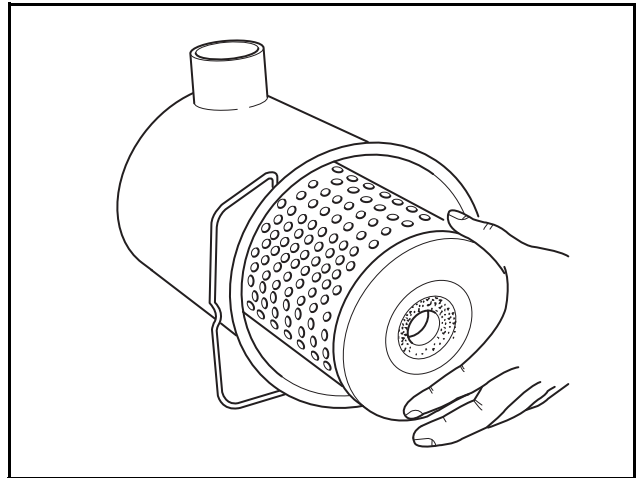

EK00025A

- 1) Unscrew the hex nut and remove the dirty element. Clean or replace it with a new one.
- 2) Thoroughly wipe the inside of the cleaner housing and the contact surface of the element seal ring with a wet rag.

### CAUTION

**Make sure that dust does not enter the tip of the air cleaner.**

## 4. Regular Inspections

### Cylinder Block/Head

#### Adjusting the Valve Clearance

- Turn the crankshaft to set the piston of cylinder no. 1 at TDC of the compression stroke; then, adjust the valve clearance.
- Unscrew the rocker arm mounting nut and fit the feeler gauge between the rocker arm and valve. Adjust the clearance of each cylinder with the adjustment screw; then, tighten the mounting nut.
- Adjust the valve clearance as follows while the engine is cold:

Specified Value		Measurement Tolerance	
Intake Valve	Exhaust Valve	Intake Valve	Exhaust Valve
0.4 mm (0.0158 in.)	0.7 mm (0.0276 in.)	±0.05 mm	

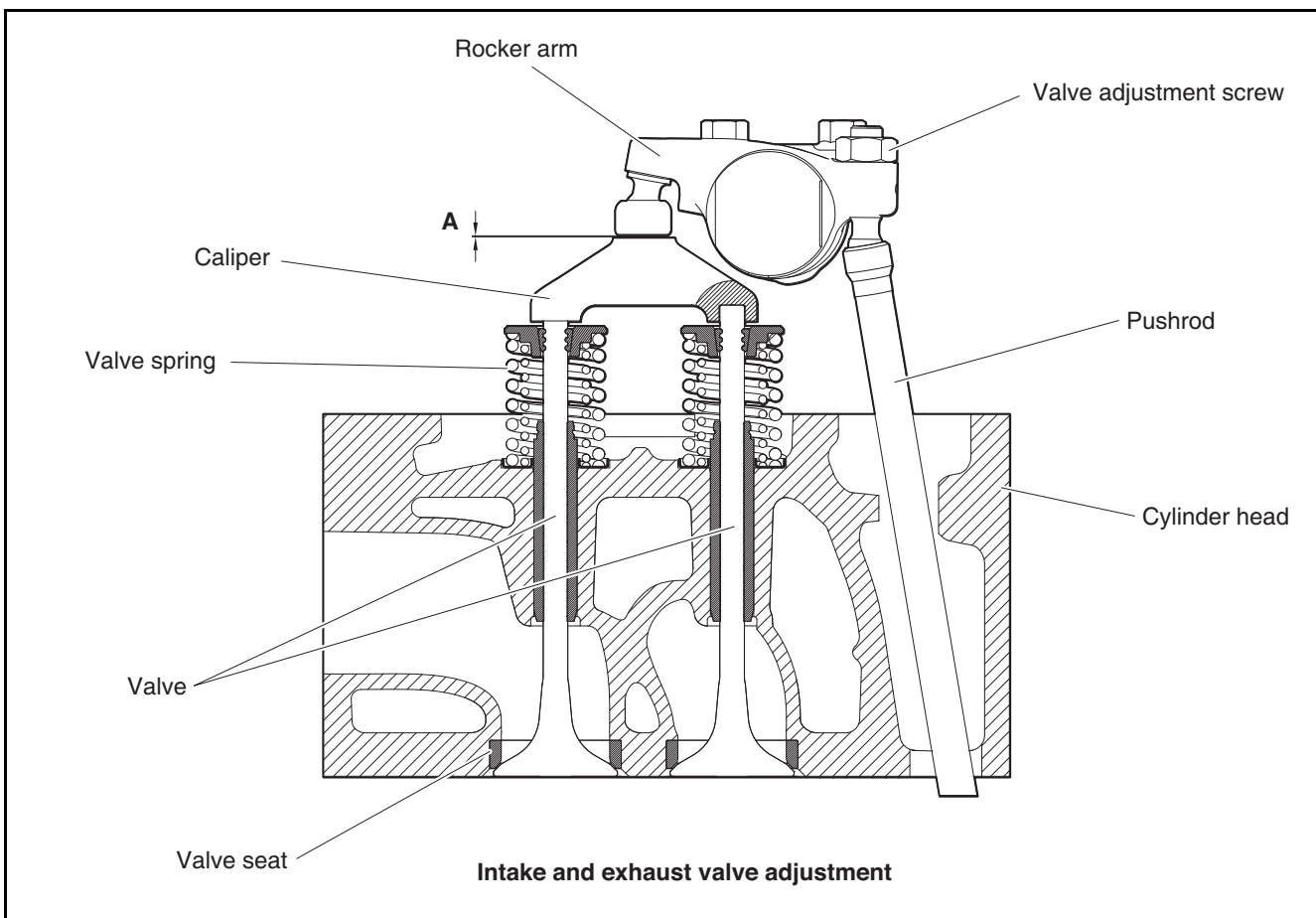

EDX22190045

### Adjusting Sequence of Valve Clearance

- Turn the crankshaft to set the piston of cylinder no. 1 at TDC of the compression stroke.

Note) Cylinder no. 1 is where the coolant pump is installed.

Note) In a 8-cylinder engine, when cylinder no. 1 is at TDC of the compression stroke, valve overlap occurs in cylinder no. 6.

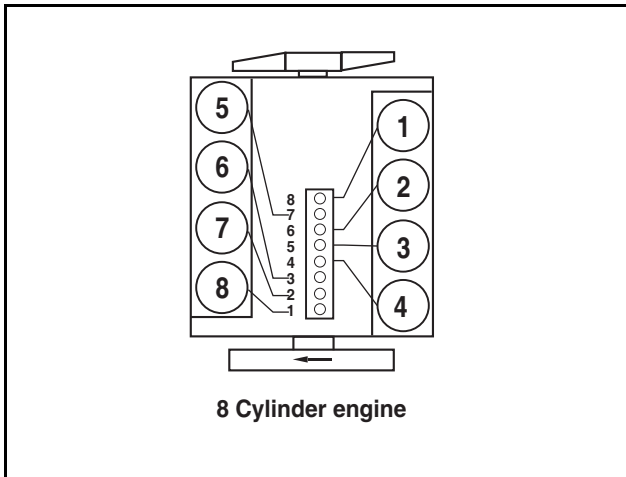

DV2213042A

- Turn the crankshaft and adjust the valve clearance of each cylinder at TDC of the compression stroke.
- Depending on the cylinder in the valve overlap stage, adjust the valve clearance of the corresponding cylinder at TDC of the compression stroke as follows.

No. of cylinder in valve overlap stage							
1	5	7	2	6	3	4	8
6	3	4	8	1	5	7	2
Valve adjustment cylinder no. (Intake & exhaust valves)							

## 4. Regular Inspections

### Electrical System

#### Battery

1. Check the battery for electrolyte leakage due to cracks. If it is cracked, replace it with a new one.
2. Check the electrolyte level and add distilled water as necessary.
3. Measure the specific gravity of the electrolyte. If the measurement is below the specified range (1.12 ~ 1.28), add more.

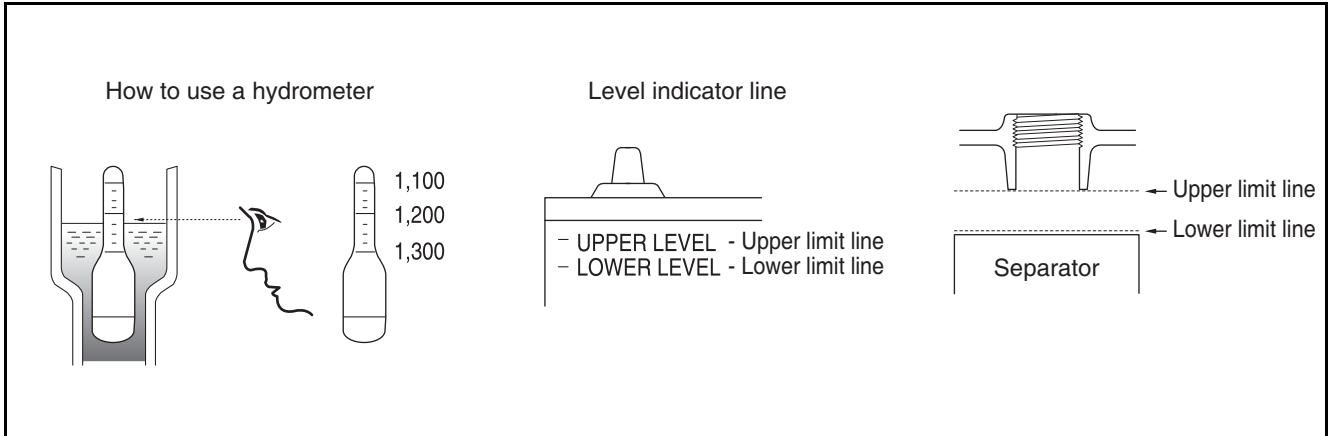

EFM1007I

### Other/Driving System

#### Belt tension

Belt tension is maintained by an auto tensioner, so there is no need to adjust it. The belt must be replaced when the pointer indicates that a replacement interval is approaching.

##### 1. Inspection conditions

- 1) Check the belt for cracks, oil residue, deformation due to heat, and wear.
2. The vertical bar (A) indicated by the arrow is the "pointer". When this "pointer" enters the horizontal range (B) indicated in orange, the belt must be replaced.

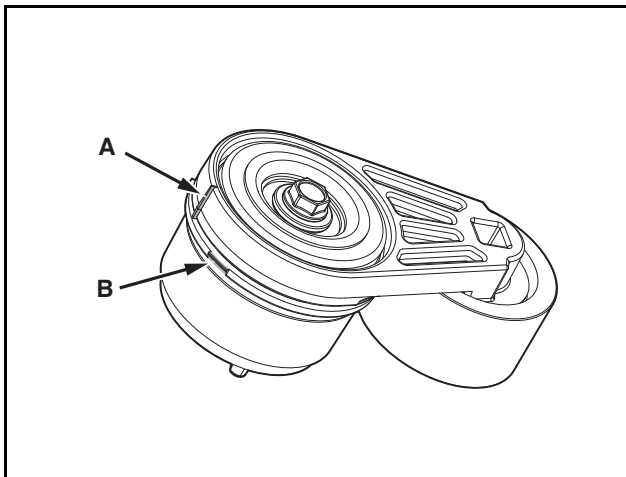

EDL022140A

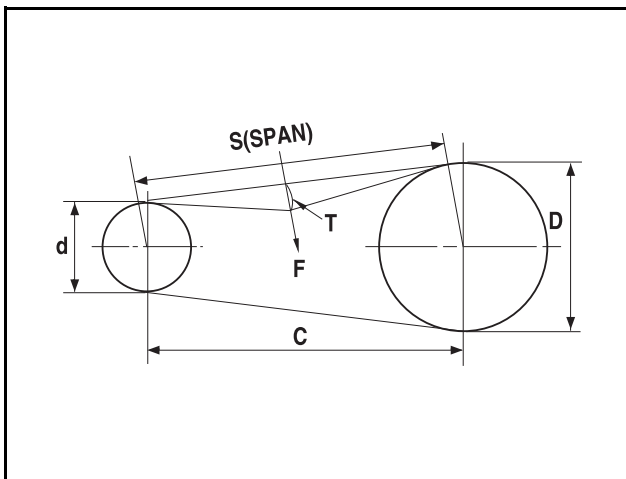

EDL022140A

- 1) The tension of the belt should be adjusted to the amount of deflection of the belt when the specified force (F) is applied to it.
- 2) Adjust the belt so that  $(T) = 0.015 \times S$  (1.5 mm per 100 mm).

Note) T : Deflection amount, S : Distance

$$3) *S = \sqrt{C^2 \frac{(D - d)^2}{2}}$$

Note) C : Center distance (mm), D : Large pulley dia. (mm), d : Small pulley dia. (mm)

#### 3. Measuring Tension

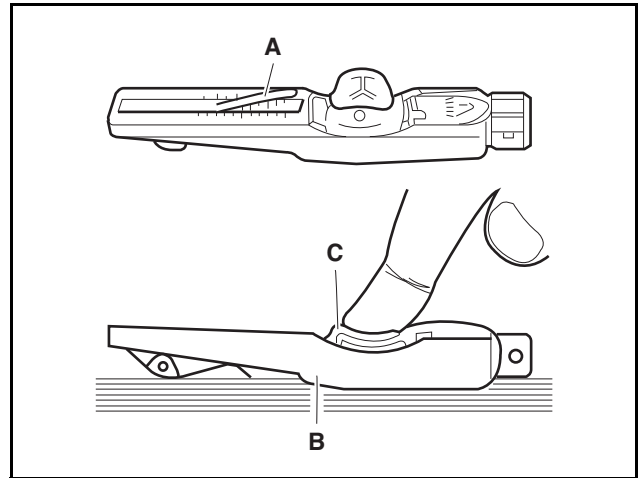

EDL022141A

- 1) Insert the belt into the protrusion (A) of the tension measuring instrument.
  - Place the measuring instrument between the pulleys and set its contact end (B) to push the belt.
  - Press the pad (C) slowly until the sound of the spring unscrewing is heard. This force pushes the tension measuring instrument upward.
  - If there is still tension left on the belt after removing the pad (C), the measurement is not accurate.
- 2) Measuring Tension
  - Read the tension value at the point where the top of the protrusion (A) of the tension measuring instrument is aligned with the scale.
  - Before reading the tension value, make sure that the needle of the measuring instrument has returned to the original position.
- 3) Adjusting Tension and Replacing the Micro-V Belt
  - Rotate the auto tensioner clockwise using the square groove in the center of the idle pulley of the auto tensioner.
  - Remove the old belt.
  - After fitting the new belt onto all of the pulleys (check to make sure the belt covers all of the belt grooves), rotate the auto tensioner clockwise to wrap the belt around the auto tensioner; then, fit the tightened auto tensioner in place.

## 4. Regular Inspections

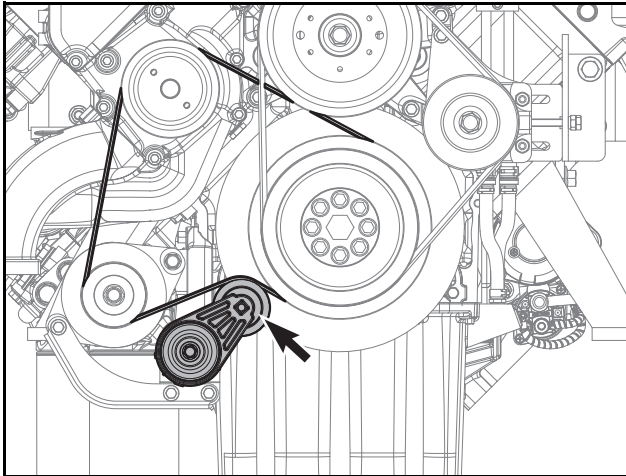

EDX15240031

4. The belt tension is as follows:

Type	Drive belt width	Tension on the tester	
		Installation (10 minutes after operation)	During service after prolonged operation (replacement interval)
8PK Micro V	27.62 mm (1.0874 in.)	358 ~ 444 N (80.48 ~ 99.82 lbf)	220 N / 49.46 lbf

5. The belt consists of the following components.

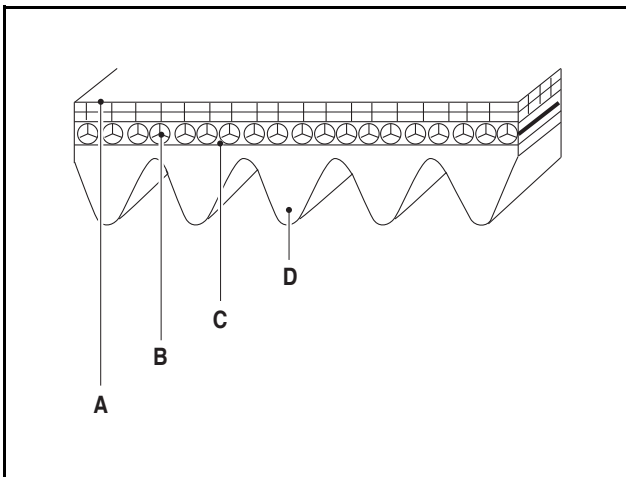

EDL022142A

1) The belt consists of the cover layer (A), cord (B), adhesive rubber (C) and belt reinforcement rubber shim (D).

## 5. General Engine Information

Method of Indicating Units .....	53
Unit Conversion Methods.....	53
Tightening Torque .....	54
Tightening Torque of Main Parts.....	54
Tightening Torque of General Bolts.....	55
Tightening Torque of Plug Screws.....	56
Tightening Torque of Hollow Screws (Four Holes) .....	56
Engine Disassembly .....	57
Order of Engine Disassembly .....	57
Engine Assembly .....	67
Order of Engine Assembly .....	67



## 5. General Engine Information

### Method of Indicating Units

#### Unit Conversion Methods

This is a method for converting between SI and US units.

1. Multiply the SI unit by the numbers in the table below to obtain the US unit.

Note) (SI unit) X (number) = (US unit)

Note) 1 mm X 0.03937 = 0.03937 in

2. Divide the US unit by the numbers in the table below to obtain the SI unit.

Note) (US unit) ÷ (number) = (SI unit)

Note) 1 in ÷ 0.03937 = 25.4 mm

Item	Number	SI Unit	US Unit
Length	0.03937	mm	in
	3.28084	m	ft
	1.093613	m	yd
	0.621371	km	mile
Area	0.00155	mm <sup>2</sup>	in <sup>2</sup>
	0.1550	cm <sup>2</sup>	in <sup>2</sup>
	10.76391	m <sup>2</sup>	ft <sup>2</sup>
	1.19599	m <sup>2</sup>	yd <sup>2</sup>
Weight	2.204623	kg	lb
	0.001	kg	t (ton)
Volume	0.061024	cc	in <sup>3</sup>
	0.061024	ml	in <sup>3</sup>
	0.061024	cm <sup>3</sup>	in <sup>3</sup>
	61.023744	L	in <sup>3</sup>
	0.264172	L	gal
Force <sup>a</sup>	2.204622	kgf	lbf
	0.2248089	N	lbf
Acceleration	3.28084	m/s <sup>2</sup>	ft/s <sup>2</sup>
	39.37008	m/s <sup>2</sup>	in/s <sup>2</sup>
Torque <sup>b</sup>	7.233014	kgf·m	lbf·ft
	86.79619	kgf·m	lbf·in
	0.7375621	N·m	lbf·ft
	8.850748	N·m	lbf·in
Power supply	1.340483	kw	Hp
Pressure	0.01	kPa	bar
	7.500615	kPa	mmHg
	20.88543	kPa	lb/ft <sup>2</sup>
	14.2233	psi	kg/cm <sup>2</sup>

Item	Number	SI Unit	US Unit
Power	1.3596	kw	PS
	0.98635	ps	hp
Fuel consumption	0.00162	g/kwh	lb/psh
Energy	0.000947817	J	BTU
	0.7375621	J	lbf·ft
	0.0002777778	J	Wh
Light	0.09290304	lm/m <sup>2</sup>	lm/ft <sup>2</sup>
Speed	0.6213712	km/h	mph
Temperature	c	°C	°F

- a.  $9.806 \times (\text{kg}\cdot\text{f}) = (\text{N})$
- b.  $9.806 \times (\text{kgf}\cdot\text{m}) = (\text{N}\cdot\text{m})$
- c.  $\{(9/5) \times (^\circ\text{C}) + 32\} = (^\circ\text{F})$   
 $\{(^\circ\text{F}) - 32\} \times (5/9) = (^\circ\text{C})$

## 5. General Engine Information

### Tightening Torque

#### Tightening Torque of Main Parts

Main Parts	Name (Dia. x pitch)	Strength	Tightening Torque
Cylinder block bearing cap			
- Main bolt	M18 × 2.0	12.9T	30 kgf·m (216.99 lbf·ft) + 90° (0 ~ 10°)
- Side bolt	M12 × 1.5	12.9T	13.4 kgf·m (96.9224 lbf·ft)
Oil spray nozzle			
- Valve	M14 × 1.5	-	7 kgf·m (50.6311 lbf·ft)
- Mounting bolt	M6	8.8T	1.2 kgf·m (8.6796 lbf·ft)
Flywheel housing	M10 × 1.5	12.9T	7.5 kgf·m (54.2476 lbf·ft)
	M12 × 1.5	12.9T	13.4 kgf·m (96.9224 lbf·ft)
	M14 × 1.5	12.9T	17 kgf·m (122.961 lbf·ft)
Balance weight	M16 × 1.5	10.9T	14 kgf·m (101.262 lbf·ft) + 90°
Crankshaft pulley	M16 × 1.5	12.9T	21 kgf·m (151.893 lbf·ft)
Vibration damper	M12 × 1.5	12.9T	13.4 kgf·m (96.9224 lbf·ft)
Flywheel	M18 × 1.5	14.9T	20 kgf·m (144.66 lbf·ft) + 90° + 90° + 55°
Connecting rod cap	M16 × 1.5	10.9T	10 kgf·m (72.33 lbf·ft) + 90°
Cylinder Head	M16 × 2.0	-	4 kgf·m (28.93 lbf·ft) + 90° + 90°
Cylinder center cover	M8 × 1.25	8.8T	2.2 kgf·m (15.91 lbf·ft)
Cylinder head cover	M8 × 1.25	8.8T	2.2 kgf·m (15.91 lbf·ft)
Rocker arm bracket	M10 × 1.5	10.9T	6.2 kgf·m (44.8447 lbf·ft)
Rocker arm adjustment nut	M10 × 1.0	8.8T	5.0 kgf·m (36.1651 lbf·ft)
Oil pump mounting	M8 × 1.25	8.8T	2.2 kgf·m (15.91 lbf·ft)
Oil Filter	M10 × 1.5	8.8T	4.4 kgf·m (31.8253 lbf·ft)
Oil cooler	M10 × 1.5	8.8T	4.4 kgf·m (31.8253 lbf·ft)
Oil pan	M8 × 1.25	10.9T	3.1 kgf·m (22.4223 lbf·ft)
Oil pan drain plug	M30 × 1.5	-	15 kgf·m (108.495 lbf·ft)
Exhaust manifold	M10 × 1.5	-	8.0 kgf·m (57.8641 lbf·ft)
Intake manifold	M8 × 1.25	8.8T	2.2 kgf·m (15.91 lbf·ft)
Hanger bracket mounting bolt	M16 × 2.0	10.9T	26.0 kgf·m (188.058 lbf·ft)
Starter motor	M12 × 1.5	8.8T	8.0 kgf·m (57.8641 lbf·ft)
Alternator bracket	M12 × 1.5	8.8T	8.0 kgf·m (57.8641 lbf·ft)
Coolant temperature sensor	M12 × 1.5	-	2.5 kgf·m (18.0825 lbf·ft)
Intake temperature sensor	M10 × 1.25	-	0.8 kgf·m (5.7864 lbf·ft)
Fuel injector mounting bracket bolt	M8	10.9T	3.0 ~ 3.5 kgf·m (21.69 ~ 25.32 lbf·ft)
High-pressure fuel pump mounting bolt	M10 × 1.5	10.9T	6.2 kgf·m (44.8447 lbf·ft)
High-pressure fuel connector nut	M22 × 1.5	-	5.5 kgf·m (39.7816 lbf·ft)
Common rail mounting bolt	M8	10.9T	2.2 kgf·m (15.91 lbf·ft)
High-pressure fuel pipe - High-pressure fuel connector	M14 × 1.5	-	4.0 kgf·m (28.9321 lbf·ft)
High-pressure fuel pipe - Common rail	M14 × 1.5	-	4.0 kgf·m (28.9321 lbf·ft)
High-pressure fuel pipe - High-pressure fuel pump	M14 × 1.5	-	4.0 kgf·m (28.9321 lbf·ft)
Fuel filter mounting bolt	M10 × 1.5	10.9T	6.2 kgf·m (44.8447 lbf·ft)

## 5. General Engine Information

### Tightening Torque of General Bolts

Refer to the following tightening torques for bolts whose tightening torque is not included in the list of the main parts.

#### 1. Tightening torque of general bolts

Name Dia. x pitch (mm)	Strength class										
	3.6	4.6	4.8	5.6	5.8	6.6	6.8	6.9	8.8	10.9	12.9
	(4A)	(4D)	(4S)	(5D)	(5S)	(6D)	(6S)	(6G)	(8G)	(10K)	(12K)
	Elastic limit (kg/mm <sup>2</sup> )										
	20	24	32	30	40	36	46	54	64	90	106
Tightening torque (kgf-m)											
M5	0.15	0.16	0.25	0.22	0.31	0.28	0.43	0.48	0.5	0.75	0.9
M6	0.28	0.30	0.45	0.4	0.55	0.47	0.77	0.85	0.9	1.25	1.5
M7	0.43	0.46	0.7	0.63	0.83	0.78	1.2	1.3	1.4	1.95	2.35
M8	0.7	0.75	1.1	1	1.4	1.25	1.9	2.1	2.2	3.1	3.8
M8 × 1	0.73	0.8	1.2	1.1	1.5	1.34	2.1	2.3	2.4	3.35	4.1
M10	1.35	1.4	2.2	1.9	2.7	2.35	3.7	4.2	4.4	6.2	7.4
M10 × 1	1.5	1.6	2.5	2.1	3.1	2.8	4.3	4.9	5	7	8.4
M12	2.4	2.5	3.7	3.3	4.7	4.2	6.3	7.2	7.5	10.5	12.5
M12 × 1.5	2.55	2.7	4	3.5	5	4.6	6.8	7.7	8	11.2	13.4
M14	3.7	3.9	6	5.2	7.5	7	10	11.5	12	17	20
M14 × 1.5	4.1	4.3	6.6	5.7	8.3	7.5	11.1	12.5	13	18.5	22
M16	5.6	6	9	8	11.5	10.5	17.9	18.5	18	26	31
M16 × 1.5	6.2	6.5	9.7	8.6	12.5	11.3	17	19.5	20	28	33
M18	7.8	8.3	12.5	11	16	14.5	21	24.2	25	36	43
M18 × 1.5	9.1	9.5	14.5	12.5	18.5	16.7	24.5	27.5	28	41	49
M20	11.5	12	18	16	22	19	31.5	35	36	51	60
M20 × 1.5	12.8	13.5	20.5	18	25	22.5	35	39.5	41	58	68
M22	15.5	16	24.5	21	30	26	42	46	49	67	75
M22 × 1.5	17	18.5	28	24	34	29	47	52	56	75	85
M24	20.5	21.5	33	27	40	34	55	58	63	82	92
M24 × 1.5	23	25	37	31	45	38	61	67	74	93	103

Note) The standard torque values specified above are based on 70% of the elastic limit of bolts.

Note) The tensile force is the tensile strength multiplied by the cross-sectional area of the screw.

Note) Special screws should be tightened to only 85% of the standard value. For example, a screw coated with MoS2 should be tightened to only 60% of the standard value.

## 5. General Engine Information

---

### Tightening Torque of Plug Screws

M10	M12	M14	M16	M18	M22	M24	M26	M30
5.0	5.0	8.0	8.0	10.0	10.0	12.0	12.0	15.0

### Tightening Torque of Hollow Screws (Four Holes)

Type of material	M8	M10	M12	M14	M16	M18	M22	M26	M30	M38
SM25C	-	1.6	2.5	3.5	4.5	5.5	9.0	13.0	18.0	30.0
SUM22L <sup>a</sup>	0.8	1.8	3.0	4.0	5.5	6.5	11.0	16.0	20.0	35.0
STS304	0.8	1.8	3.0	4.0	5.5	6.5	11.0	16.0	20.0	35.0

a. Installed in HD Hyundai Infracore engines

### Engine Disassembly

#### Order of Engine Disassembly

#### **⚠ CAUTION**

- Before disassembly, prepare a shelf for parts to store various tools and disassembled parts.
- When performing disassembly, make sure to use clean, bare hands and keep the workspace and its surroundings clean.
- Make sure to store parts in such a way that they do not bump into one another after being disassembled.
- Store the disassembled parts in the order of disassembly.
- Before disassembling parts, remove the ground power source of the battery.

Disassemble the engine in the following order.

#### 1. Coolant

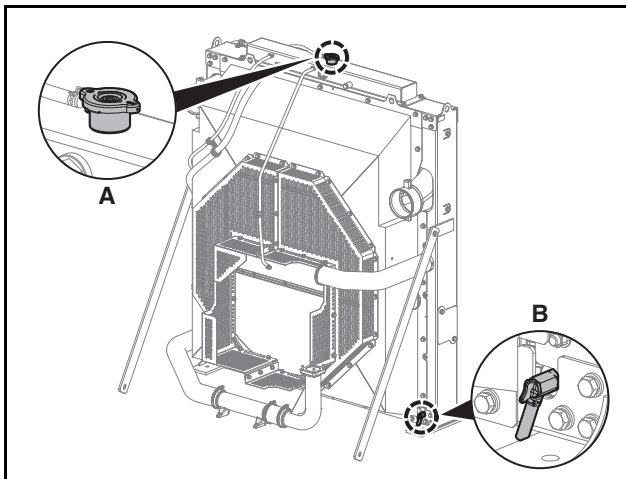

EDX15240028

- 1) Remove radiator cap (A) and open drain valve (B) on the bottom of the radiator to drain coolant as shown in the figure on the right.

#### **⚠ CAUTION**

When removing the radiator cap while the engine is hot, wrap the cap in a cloth and unscrew it slowly to release steam pressure inside. In doing so, injuries due to hot steam can be prevented.

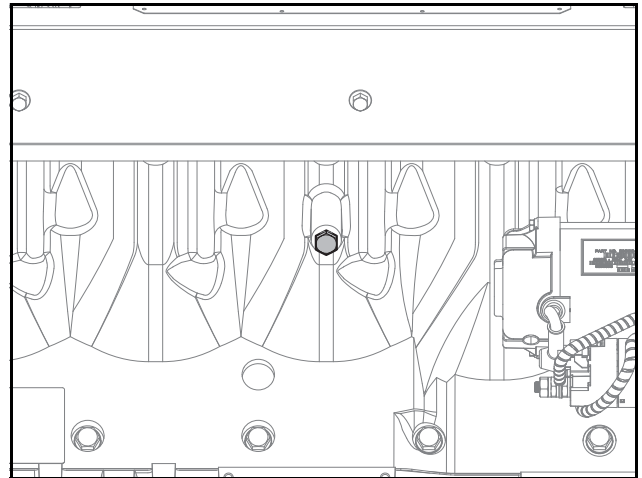

EDX22230006

- 2) Remove the coolant drain plug from the cylinder block and drain coolant into a suitable container.

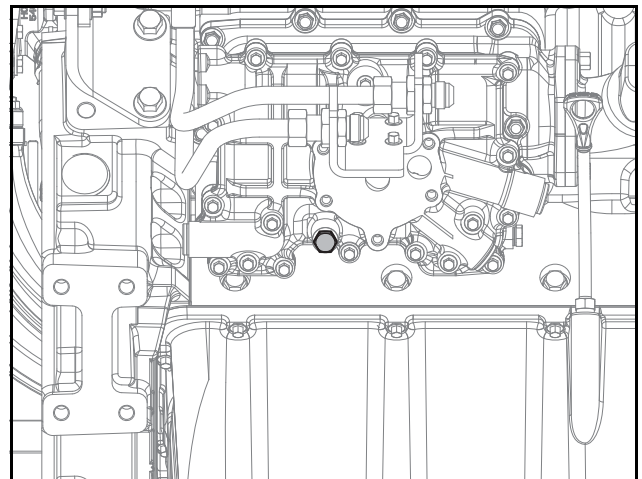

EDX15240027

#### 2. Intercooler

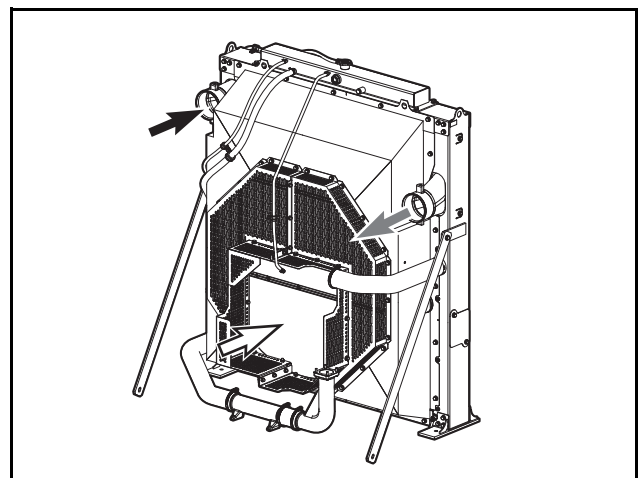

EDX15240029

- 1) Disconnect the hoses and air pipes connected to the intercooler.

## 5. General Engine Information

- 2) Unscrew the intercooler mounting bolts and remove the intercooler.
3. Oil level gauge

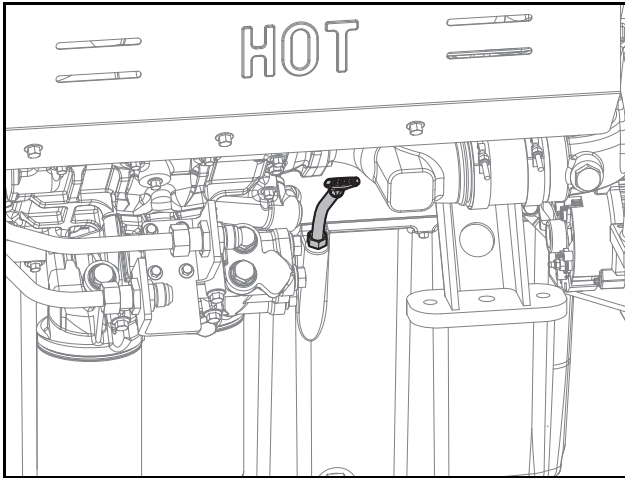

EDX15240026

- 1) Remove the oil level gauge from the oil pan guide tube.
4. Engine oil

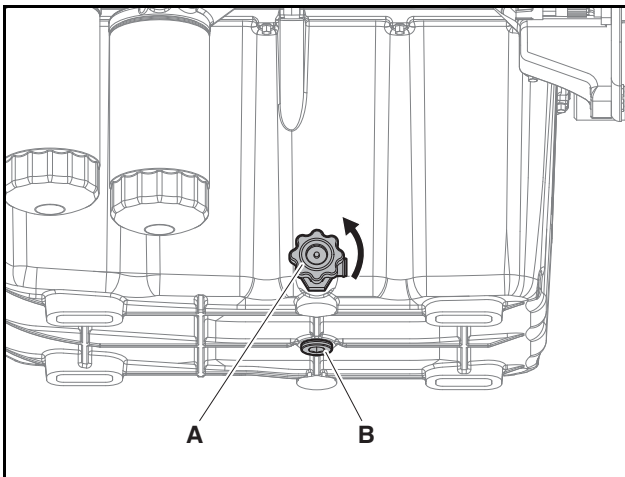

EDX15240080

- 1) Open either drain handle (A) or drain plug (B) and drain the engine oil into a suitable container.
5. Cooling fan

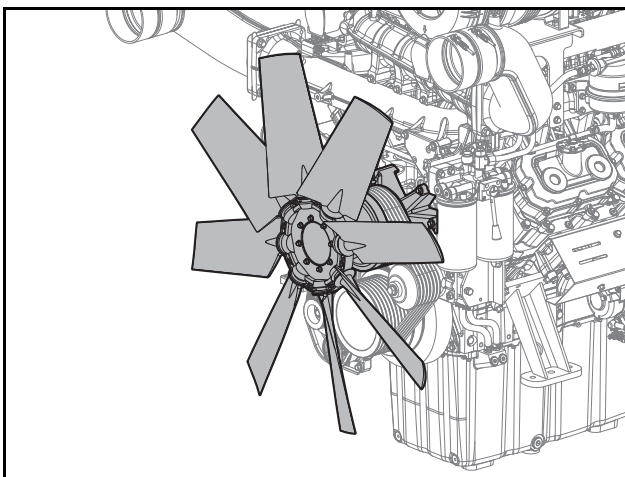

EDX15240030

- 1) Unscrew the cooling fan mounting bolts and remove the cooling fan.
6. V-belt

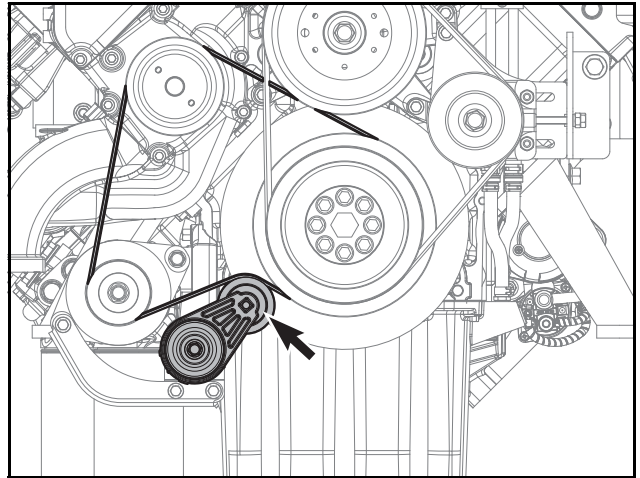

EDX15240031

- 1) Rotate the auto tensioner clockwise and remove the belt.
7. Alternator

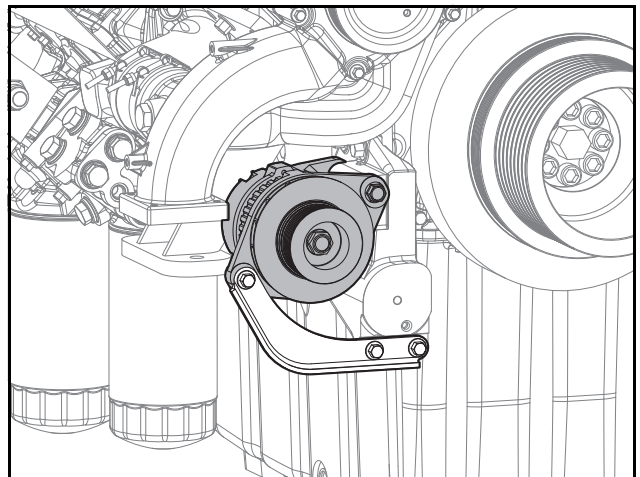

EDX15240032

- 1) Unscrew the alternator bracket bolts and hinge bolts and remove the alternator.

## 5. General Engine Information

### 8. Air pipe

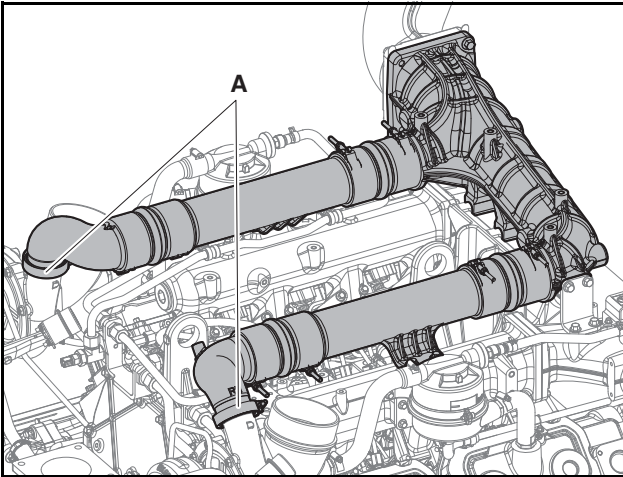

EDX15240033

- 1) Loosen and remove connecting clamps (A) on the outlet of the intake manifold compressor.
- 2) Be careful not to allow foreign matter to enter the turbocharger.

### 9. Turbocharger

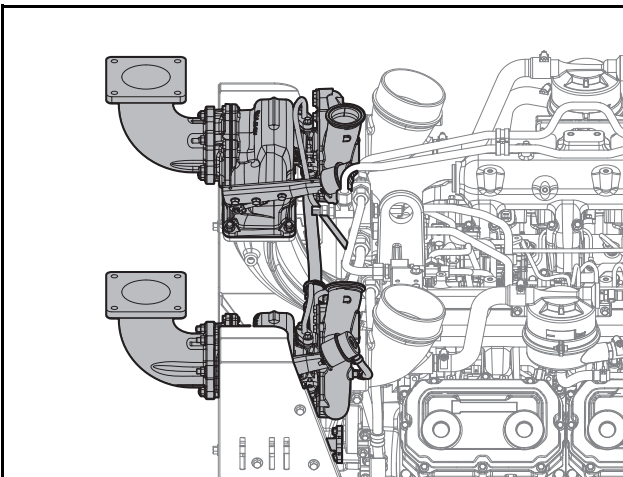

EDX15240034

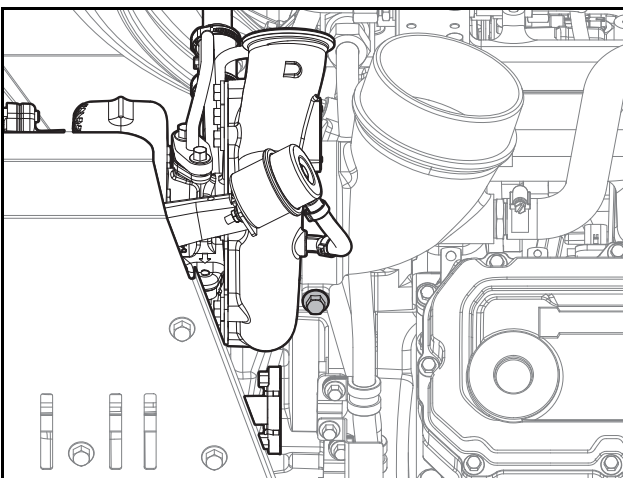

EDX15240035

- 1) Unscrew the bolts on the inlet of the intake manifold compressor and disconnect the air pipe.

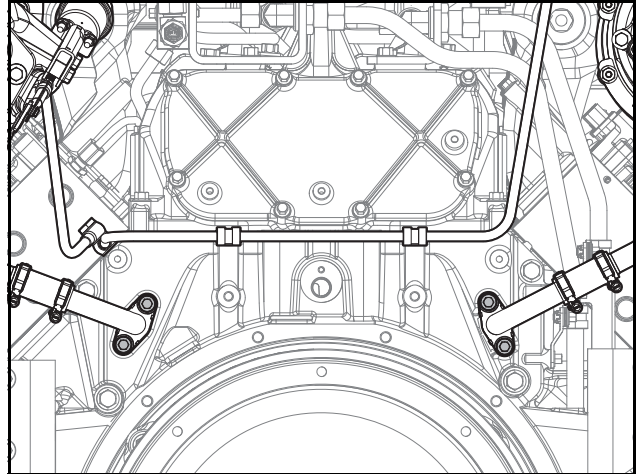

EDX15240036

- 2) Unscrew the hollow screws on the turbocharger lubricating oil supply and disconnect the oil pipes.
- 3) Unscrew the bolts on the turbocharger lubricating oil drain and disconnect the oil pipes.

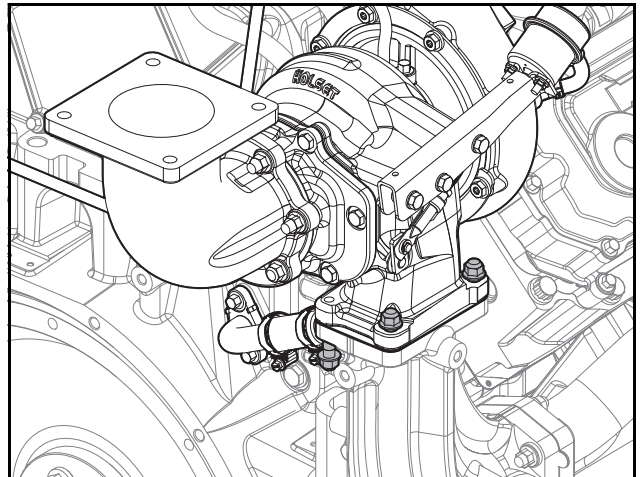

EDX15240037

- 4) Unscrew the turbocharger mounting nuts and remove the turbocharger from the exhaust manifold.

## 5. General Engine Information

### 10. Oil Filter

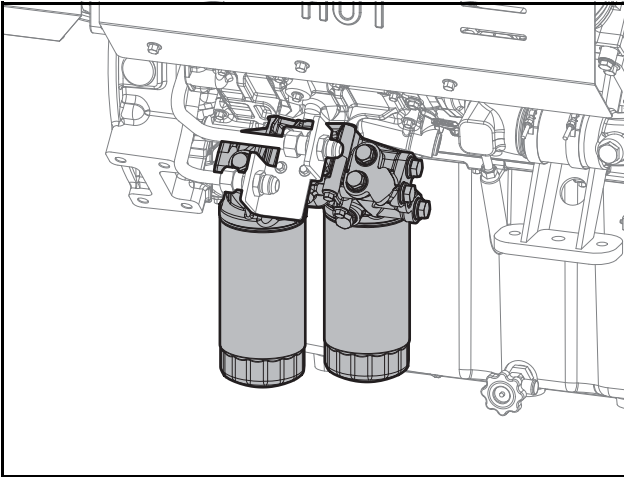

EDX15240025

- 1) Use an oil filter wrench to remove the oil filter cartridge.
- 2) Do not reuse the cartridge.

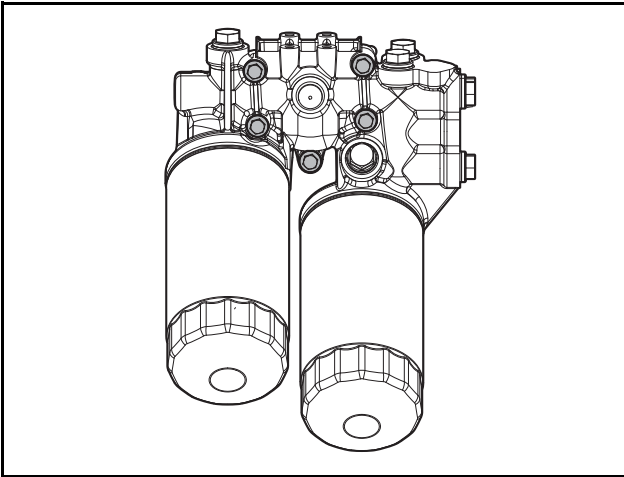

EDX15240038

- 3) Loosen the oil filter mounting bolts and remove the filter head.

### 11. Vibration damper

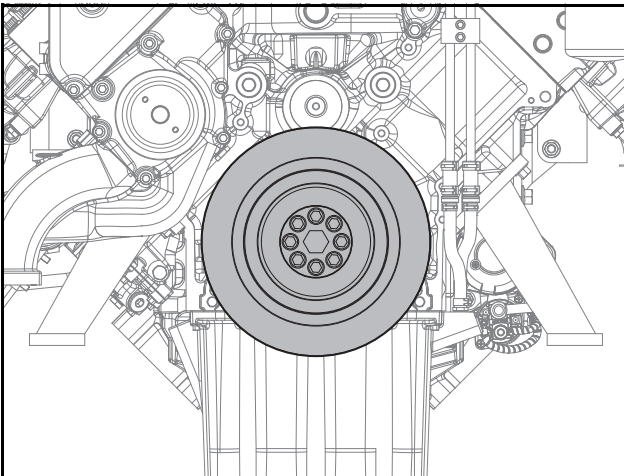

EDX15240039

- 1) Unscrew the crankshaft pulley mounting bolts and remove both the crankshaft pulley and the vibration damper.

### 12. Coolant pump and thermostat

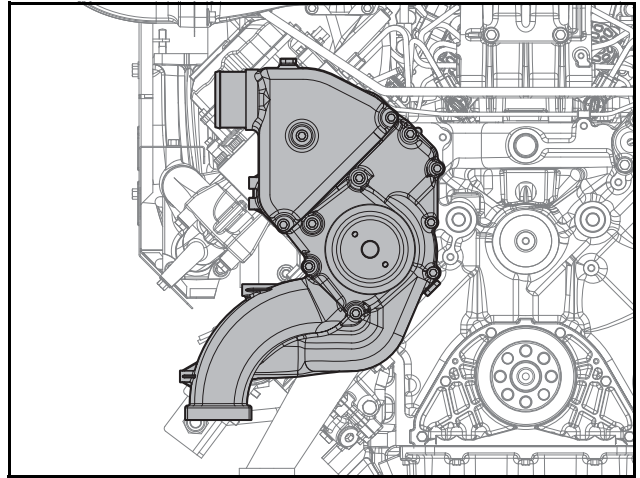

EDX15240040

- 1) Loosen the various connecting hose clamps.
- 2) Loosen the coolant drain pipes and remove the thermostat.
- 3) Unscrew the coolant pump mounting bolts and remove the coolant pump.

### 13. Starter Motor

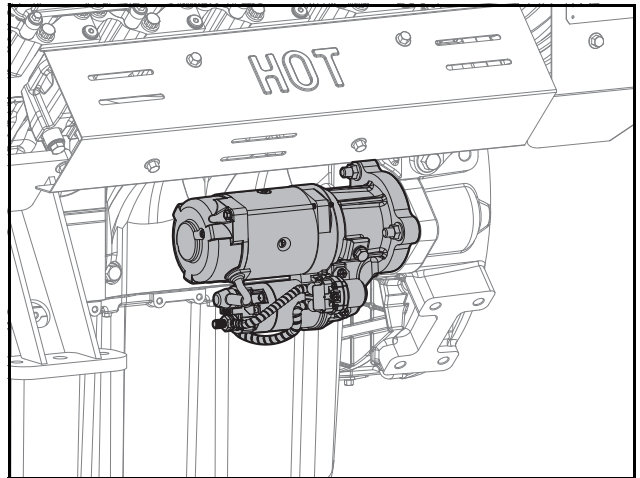

EDX15240041

- 1) Unscrew the starter motor mounting nuts and remove the starter motor.

## 5. General Engine Information

### 14. Fuel filter

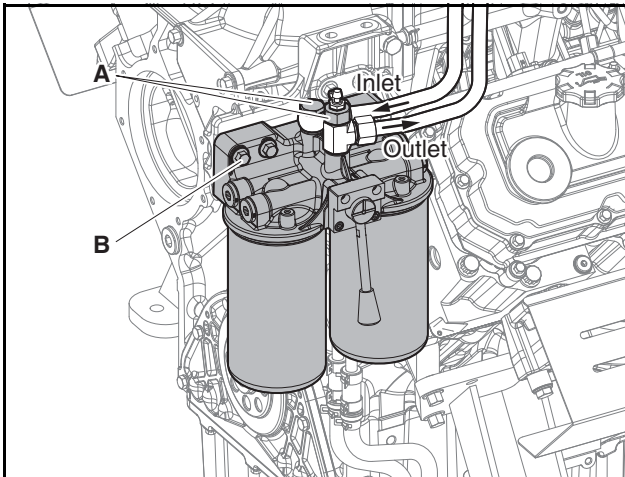

EDX15240042

- 1) Unscrew hollow screws (A) on the fuel filter and disconnect the fuel pipes.
- 2) Unscrew fuel filter mounting bolts (B) and remove the fuel filter assembly.

### 15. Fuel injection pipe

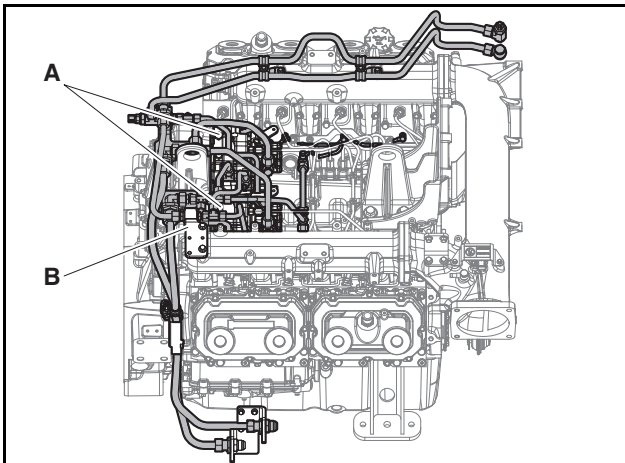

EDX15240043

- 1) Disconnect the low-pressure fuel delivery and fuel return pipes between the fuel pumps (A) and junction block (B).
- 2) Disconnect the high-pressure pipe between the high-pressure fuel connector and the common rail.

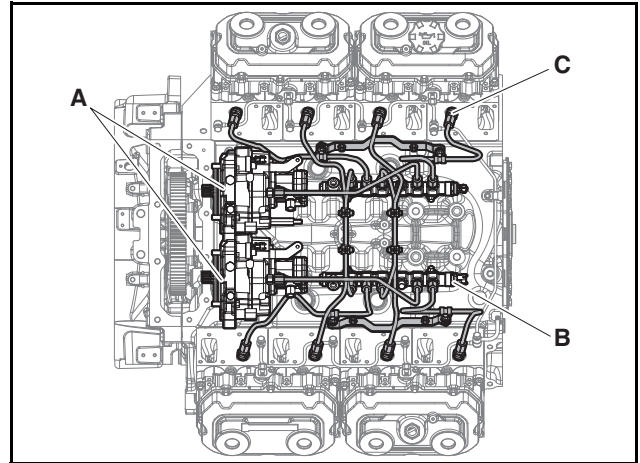

EDX15240044

- 3) Disconnect the high-pressure pipes between common rail (B), high-pressure fuel connectors (C) and fuel pumps (A).

### 16. Common rail

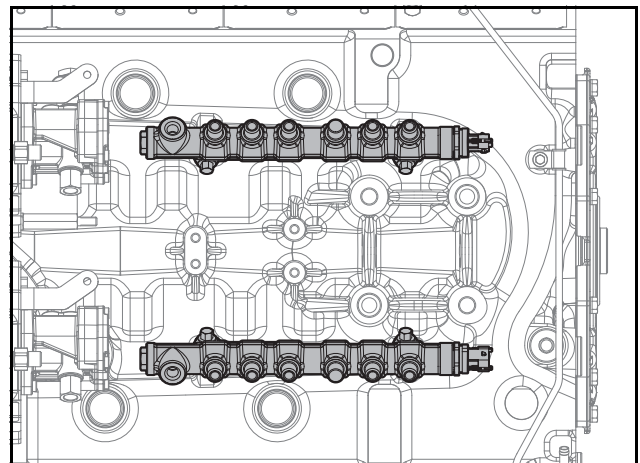

EDX15240045

- 1) Unscrew the common rail mounting bolts and remove the common rail.

## 5. General Engine Information

### 17. Intake manifold

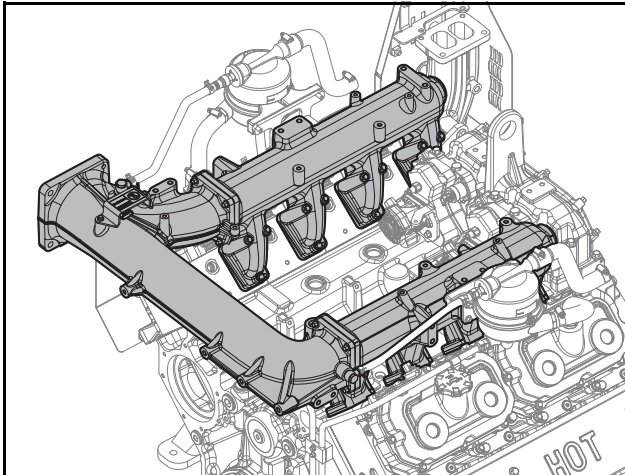

EDX15240046

- 1) Loosen the hose clamps connected to the oil-water separator.
- 2) Unscrew the oil-water separator bracket mounting bolts and remove the bracket.
- 3) Unscrew the intake manifold mounting bolts and remove the intake manifold from the cylinder head.

### 18. Exhaust manifold

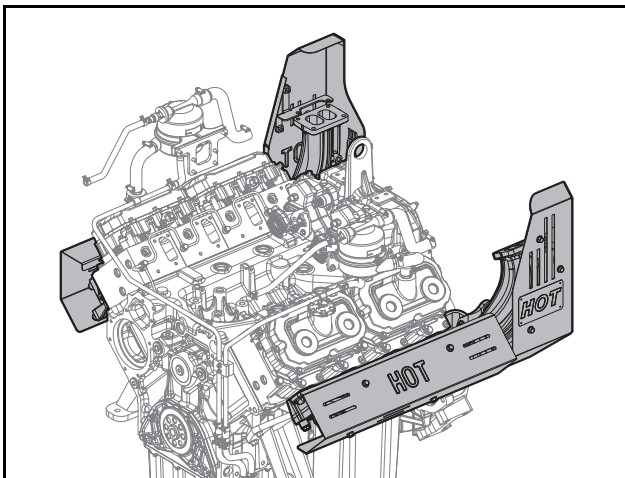

EDX15240047

- 1) Unscrew the exhaust manifold mounting bolts and remove the exhaust manifold from the cylinder head.

### 19. Oil cooler

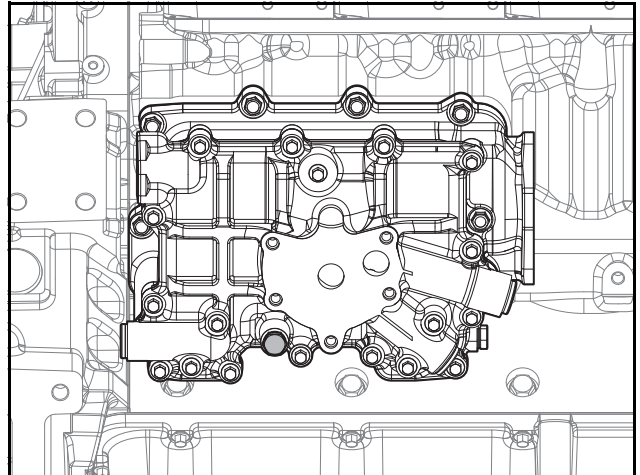

EDX15240048

- 1) Remove the coolant drain plug and drain the coolant.
- 2) Unscrew the oil cooler cover mounting bolts and remove the oil cooler.

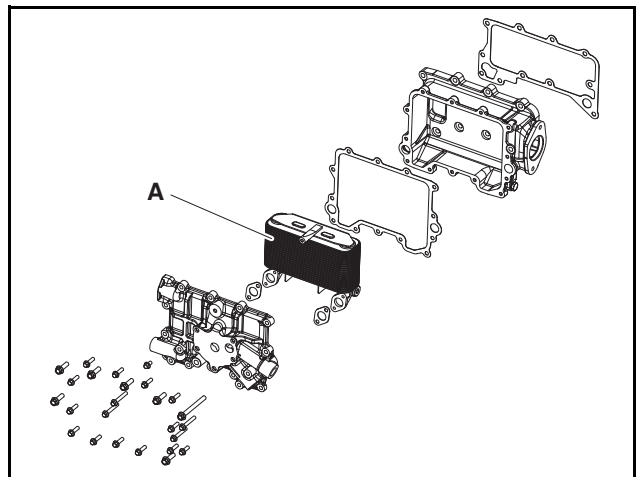

EDX15240049

- 3) Secure the oil cooler in a vice and remove the oil cooler mounting bolts; then, insert and reassemble cooler (A).

### 20. Fuel injection pump

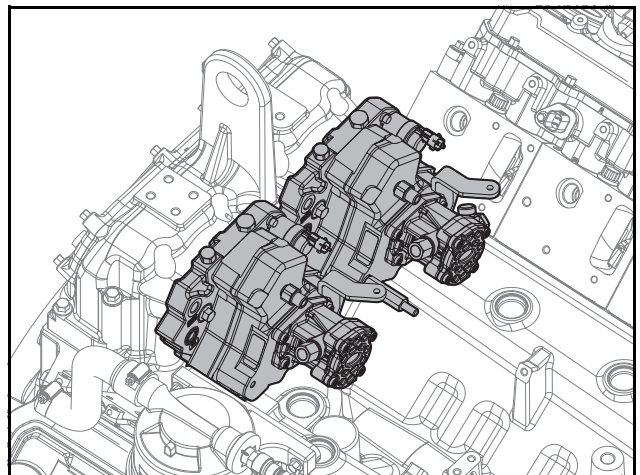

EDX15240050

## 5. General Engine Information

- 1) Loosen the high-pressure fuel pump mounting bolts and remove both high-pressure pumps from the timing gear case.

### 21. Cylinder head cover

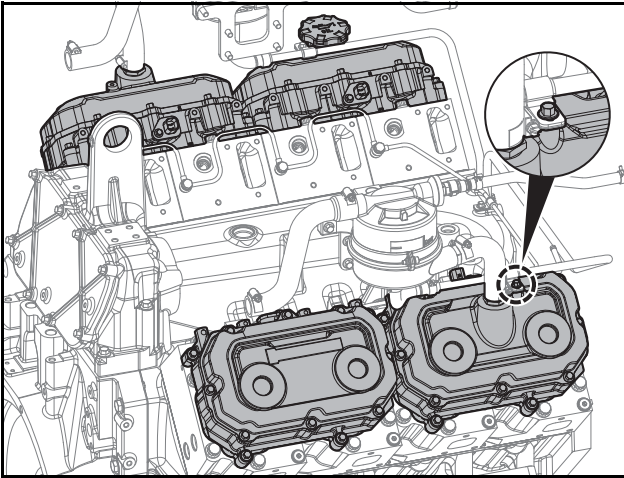

EDX15240051

- 1) Unscrew the oil drain pipe mounting bolts and remove the oil drain pipe.
- 2) Unscrew the mounting bolts and remove the cylinder head cover.

### 22. Rocker arms

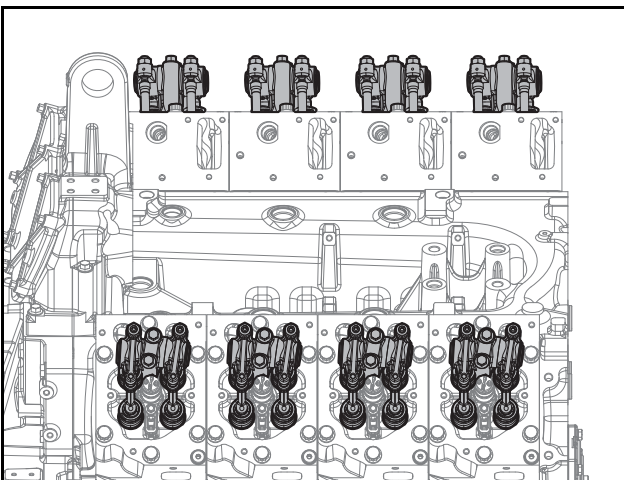

EDX15240052

- 1) Unscrew the rocker arm bracket mounting bolts and remove the rocker arm assemblies.
- 2) Remove the calipers and pushrods.

### 23. Injectors

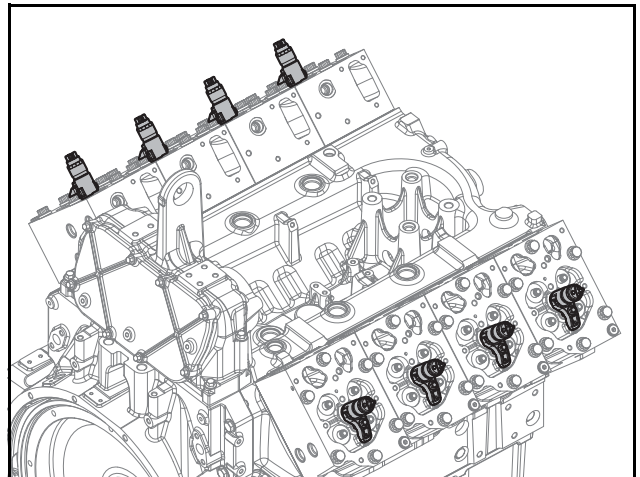

EDX15240053

- 1) Unscrew the mounting nuts on the high-pressure fuel connectors and remove the high-pressure fuel connectors.
- 2) Do not reuse high-pressure fuel connectors.
- 3) Remove the harness connected to the injectors, unscrew the injector mounting bracket bolts, and remove the injectors.
- 4) Be careful not to damage the nozzle while removing the injector.
- 5) Pull out the seal ring from the nozzle hole on the cylinder head and discard it.

## **⚠ CAUTION**

- When removing the injector, unscrew the high-pressure fuel connector mounting nut and completely disconnect the high-pressure fuel connector; then, unscrew the caliper mounting bolt on the injector and remove the injector.
- After disassembly, seal the injector and high-pressure fuel connector to prevent foreign matter from entering them.

### 24. Cylinder Head

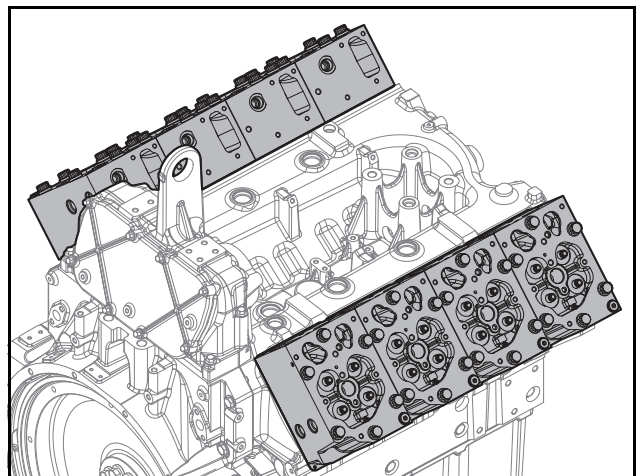

EDX15240054

## 5. General Engine Information

- 1) Unscrew the cylinder head mounting bolts in the reverse order of assembly and remove the cylinder head.
- 2) Remove and discard the cylinder head gasket.
- 3) Remove the residue on the contact surface between the cylinder head and cylinder block.

### CAUTION

**Be careful not to damage the cylinder head gasket contact surface.**

#### 25. Oil pan

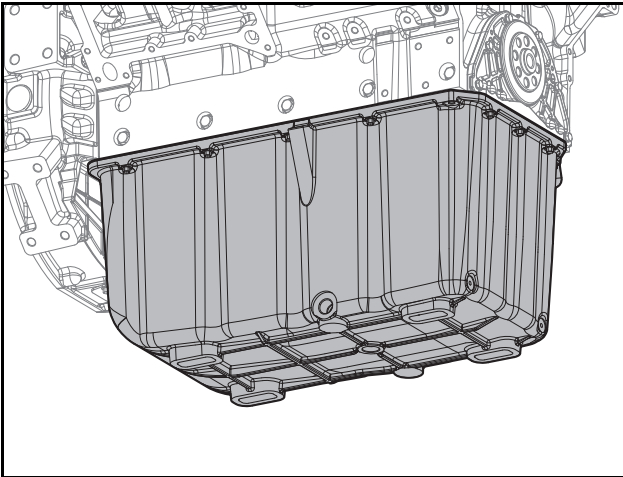

EDX15240055

- 1) Loosen the oil pan mounting bolts and remove the oil pan.
- 2) Remove and discard the oil pan gasket.

#### 26. Oil pump

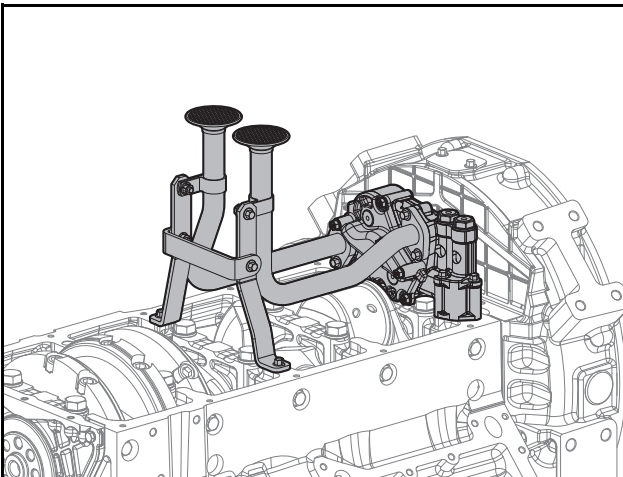

EDX15240056

- 1) Remove the oil suction pipe mounting bolts and remove the oil suction pipes.
- 2) Remove the oil pump mounting bolts and remove the oil pump.

#### 27. Pistons

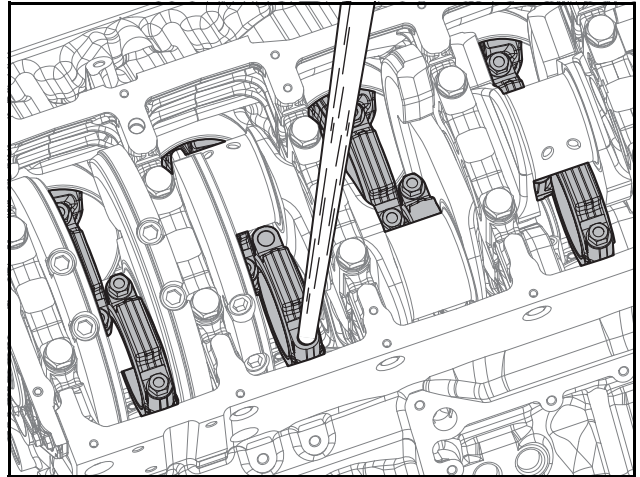

EDX15240057

- 1) Unscrew the connecting rod cap bolts in the reverse order of assembly; then, tap lightly on the top and bottom of the connecting rod cap with a urethane hammer to remove the cap and pull out the bearing.
- 2) Push a wooden stick into the bottom of the piston and remove the piston in the direction of the cylinder head.

### CAUTION

**Make sure that removed pistons do not bump into other pistons or parts.**

**Store pistons in order of their cylinders. (Temporarily assemble the connecting rods to avoid mixing up the connecting rod caps.)**

#### 28. Front oil seal holder

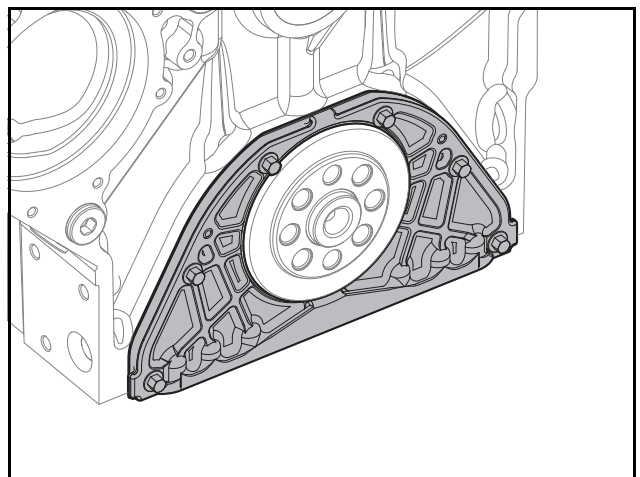

EDX22190093

- 1) Unscrew the oil seal holder mounting bolts and remove the oil seal holder.
- 2) Remove the oil seal and gasket from the oil seal holder and discard them.

## 5. General Engine Information

### 29. Flywheel

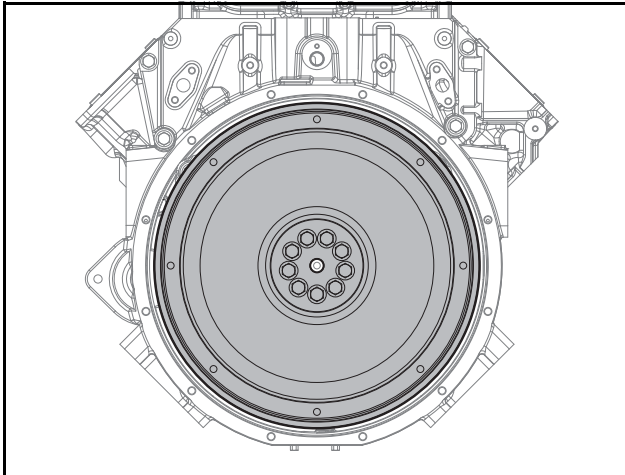

EDX15240059

- 1) Unscrew the flywheel mounting bolts in the reverse order of assembly and remove the flywheel.
- 2) Remove the flywheel ring gear.
  - a) Heat the ring gear (up to 200°C / 392°F) with a gas burner to expand it.
  - b) Tap around the ring gear with a hammer and brass rod to remove the ring gear.

### **⚠ CAUTION**

**Take care not to damage the flywheel.**

### 30. Flywheel housing

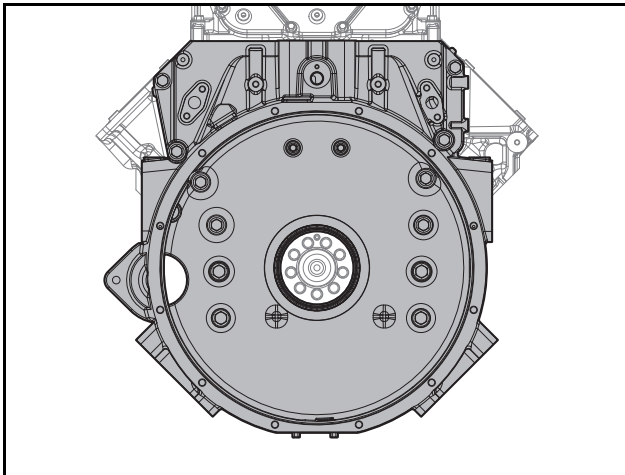

EDX15240060

- 1) Unscrew the flywheel housing mounting bolts and remove the flywheel housing.
- 2) Remove the oil seal from the flywheel housing.

### 31. Crankshaft

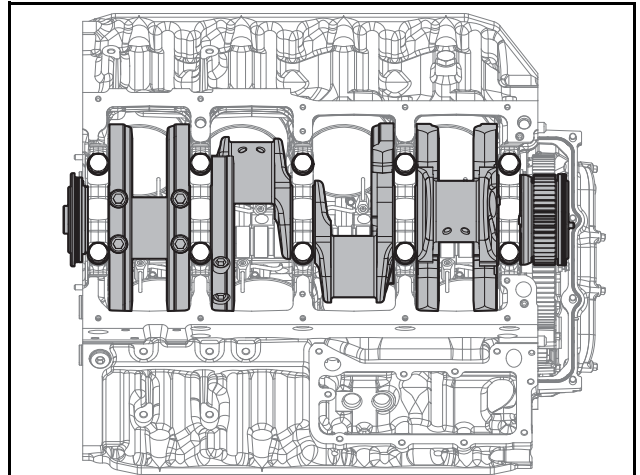

EDX15240061

- 1) Remove the bolts from the bearing caps.
- 2) Remove the main bearing cap mounting bolts in the reverse order of assembly.  
(Follow the same instructions to remove the cylinder head bolts.)
- 3) Store the removed bearing caps in order of their cylinders.
- 4) Temporarily install bolts on both sides of the crankshaft, and use ropes to lift the crankshaft.

### **⚠ CAUTION**

**Take care not to mix up bearings and bearing caps from different cylinders.**

**(To avoid confusion, temporarily assemble the bearings in their respective caps.)**

### 32. Camshaft and tappet

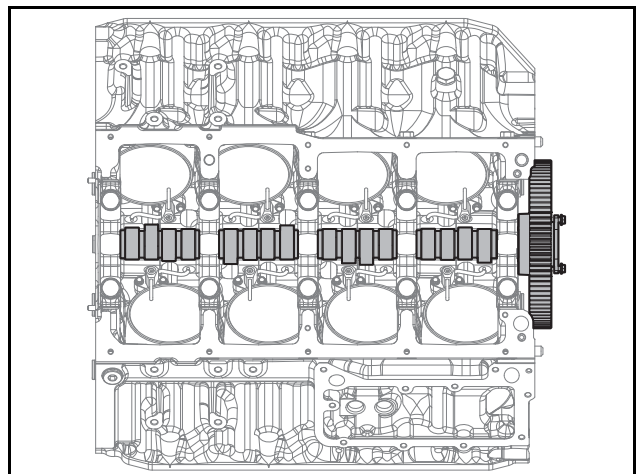

EDX15240062

- 1) Pull the tappets out of the cylinder block.
- 2) Remove the camshaft while taking care not to damage the camshaft and bearing.

## 5. General Engine Information

---

### 33. Oil injection nozzle

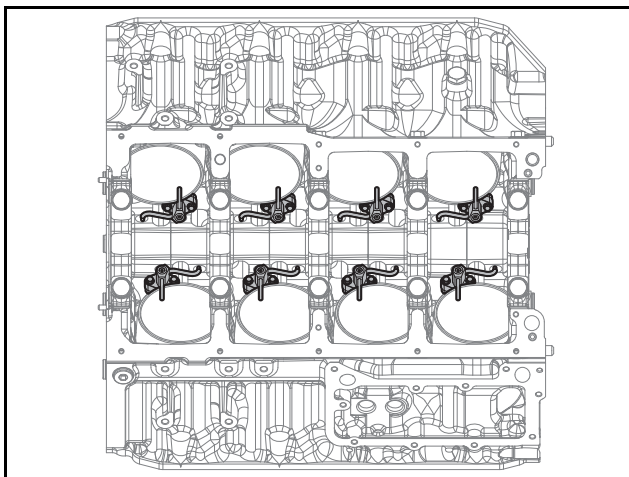

EDX15240063

- 1) Unscrew the oil injection nozzle mounting bolts and remove the oil injection nozzles.

### 34. Cylinder liner

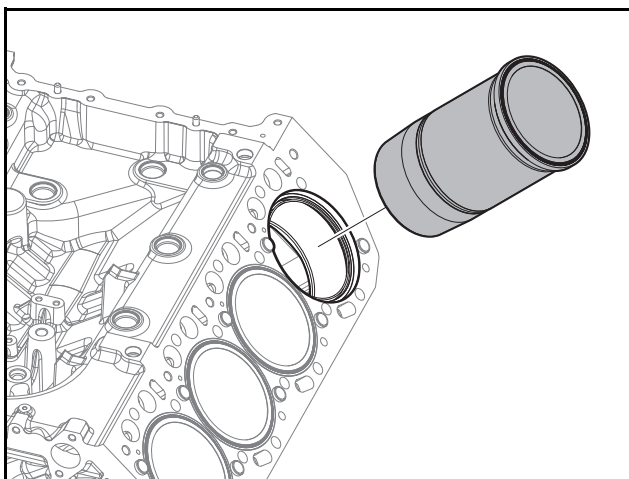

EDX15240064

- 1) Use a special tool to pull the cylinder liner out of the cylinder block.

## 5. General Engine Information

### Engine Assembly

#### Order of Engine Assembly

#### CAUTION

- Clean all parts thoroughly and blow compressed air into the various oil and coolant passages to clean them out completely.
- Arrange the various special and general tools for assembly in order.
- Prepare clean engine oil to apply to each moving part.
- Prepare other materials such as sealant.
- Use ThreeBond as an adhesive in the engine oil circuit and silicone in the cooling circuit.
- Used gaskets, seal rings and other consumable parts should be discarded and replaced with new ones.
- Each bolt should be tightened to its specified torque in order and should not be overtightened.
- After assembling engine components, check to make sure that the engine moves smoothly.
- After assembly is complete, check each bolt for looseness.
- After completely assembling the engine, check for any missing or faulty parts.
- Keep your hands clean while working.

#### 1. Cylinder liner

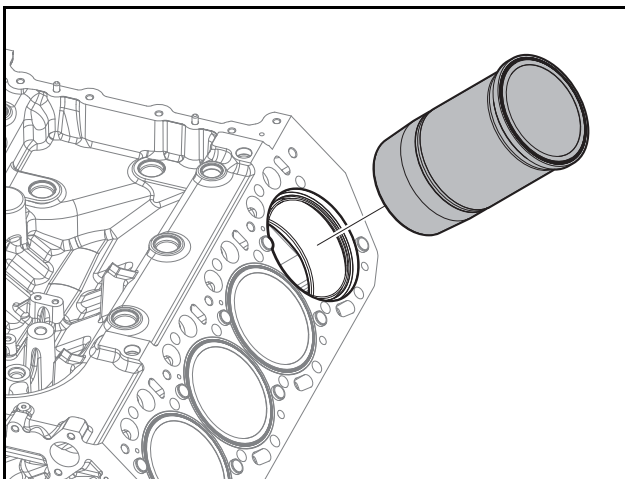

EDX15240064

- 1) Replace the O-rings with new ones. Insert the upper O-ring into the cylinder liner and the lower O-ring into the cylinder block.
- 2) Apply oil to the O-ring joint.
- 3) After gently inserting the cylinder liner into the liner hole in the cylinder block, insert the O-ring while taking care not to damage it.

- 4) After completely assembling the cylinder liner, perform a hydrostatic test (4 kg/cm<sup>2</sup>) to check for leaks.

#### 2. Oil injection nozzle

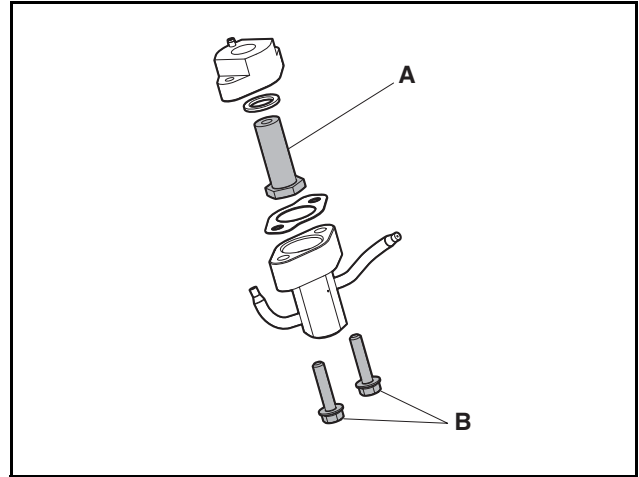

EDX22190109

- 1) Tighten the oil injection nozzle flange with hollow screw (A).
- 2) Assemble the oil injection nozzle with mounting bolts (B).

Hollow screw torque	7 kgf·m (50.6311 lbf·ft)
Mounting bolt torque	1.2 kgf·m (8.6796 lbf·ft)

#### 3. Crankshaft

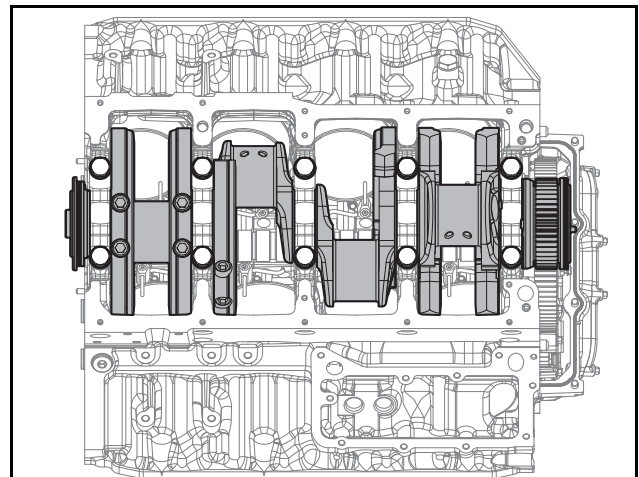

EDX15240061

- 1) Place the wear ring in a heater and heat it to 150 ~ 200°C (302 ~ 392°F); then, use a jig to fit it onto the crankshaft.

## 5. General Engine Information

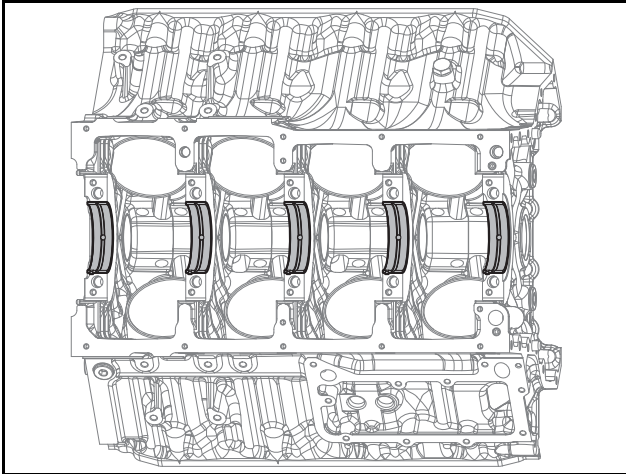

EDX15240065

- 2) Assemble the main bearings on the cylinder block and apply engine oil to the bearings. When doing so, assemble the bearings with holes on the cylinder block and the bearings without holes on the bearing caps, taking care not to mix them up.

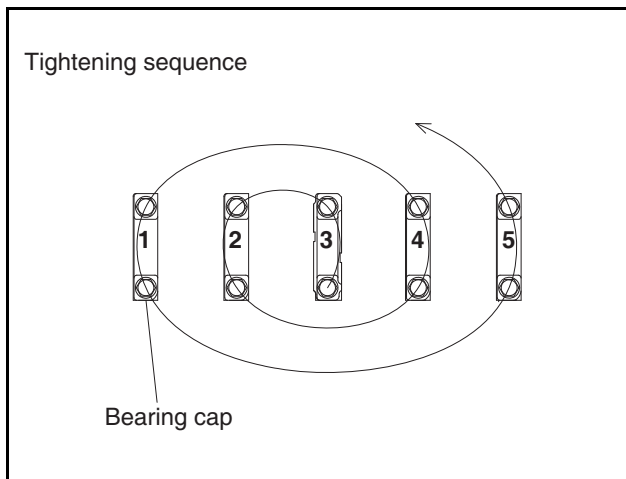

EDX15240082

- 3) Temporarily assemble one bolt in each bolt hole on either side of the crankshaft; then, after attaching wires, lift the crankshaft with a crane or chain block and lower it carefully onto the cylinder block.
- 4) Apply engine oil to the crankshaft journal and pin, and fit the main bearings in the bearing caps; then, check the numbers to avoid mixing up the bearing caps and install them on the cylinder block.

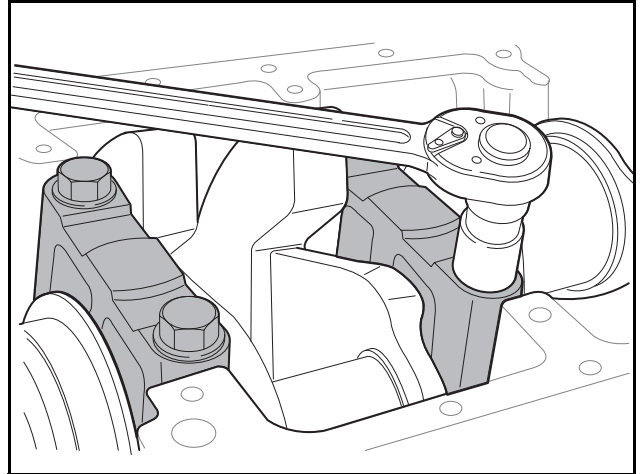

EFM2062I

- 5) Assemble the bearing cap bolts in the correct tightening sequence at the specified tightening torque (30 kgf·m / 216.99 lbf·ft) using the rotating angle method (90°+10°). The tightening sequence is as follows.

< Bearing cap tightening sequence >

- Step 1: Tighten the bolts one or two threads by hand
- Step 2: Use a wrench to tighten them to approx. 15 kgf·m (108.495 lbf·ft)
- Step 3: Tighten them with a torque wrench (approx. 25 kgf·m / 180.8 lbf·ft)
- Step 4: Tighten them with a torque wrench (approx. 30 kgf·m / 217 lbf·ft)
- Step 5: Tighten them one last time with the rotating angle method (90° + 10°)

Make sure to tighten the bolts in several steps according to the tightening sequence above.

- 6) Check whether the crankshaft rotates smoothly.
  - 7) Assemble the crankshaft gear with the crankshaft and mark gear tooth "1" with white paint to identify it easily.
4. Tappet

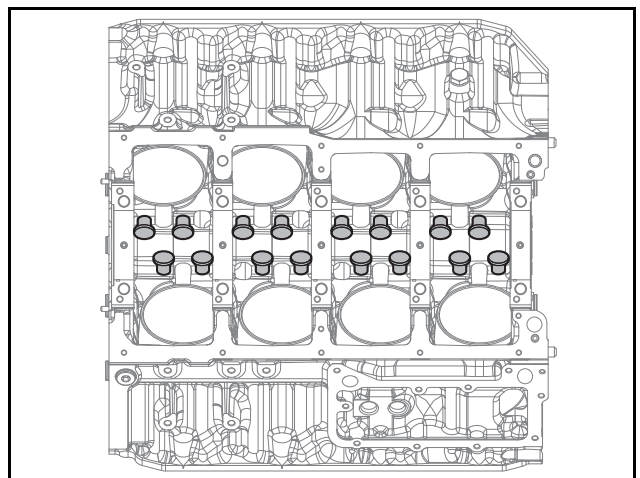

EDX15240066

- 1) Apply clean oil to the face of the tappet and insert the tappet into the tappet hole in the cylinder block.

## 5. General Engine Information

### 5. Camshaft

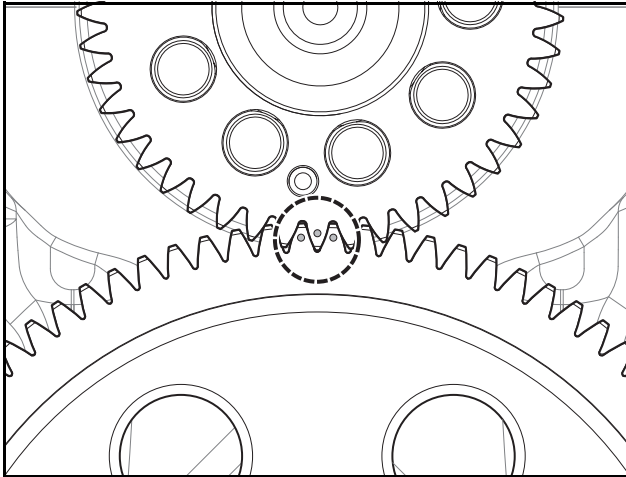

EDX22190112

- 1) Apply engine oil to the cylinder block cam bushing and camshaft.
- 2) Take care not to damage the cam bushing and camshaft.
- 3) Check to make sure that the markings on the crankshaft gear and camshaft gear are aligned when assembling them.
6. Flywheel housing

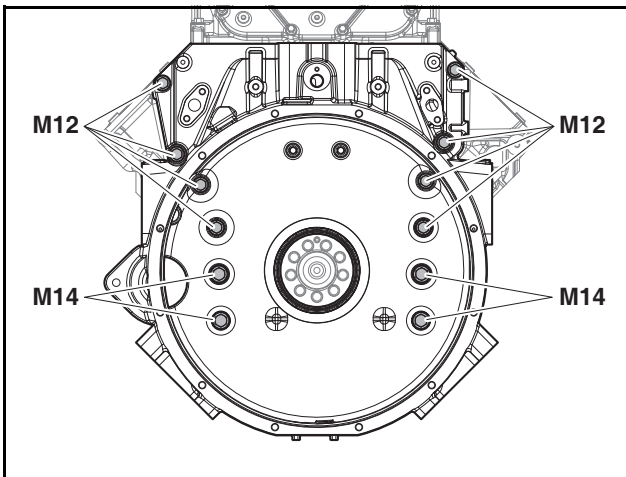

EDX15240083

- 1) Before assembling the flywheel housing with the cylinder block, assemble the flywheel housing as follows first.
- 2) Apply Loctite to the thrust washer mounting bolts and tighten them to the specified torque.

Torque	M14 x 1.5p (12.9T)	17.0 kgf·m (122.961 lbf·ft)
	M12 x 1.5p (12.9T)	13.4 kgf·m (96.92 lbf·ft)

- 3) Apply lubricant to the oil seal and use a special tool to assemble it while taking care not to misalign or damage the seal.
- 4) Apply a gasket to the cylinder block surface where the flywheel housing is to be mounted. (Grease the cylinder block surface to prevent the gasket from coming off.)

- 5) Temporarily install two flywheel housing assembly guide bolts on the cylinder block.
- 6) Fit the flywheel housing holes onto the guide bolts and temporarily tighten the mounting bolts 2 ~ 3 threads; then, tighten them to the specified torque in the correct tightening sequence (zigzag pattern).
7. Cam & CRS sensor

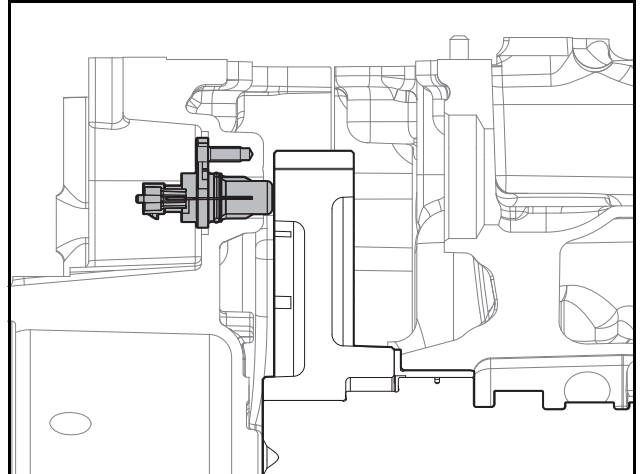

EDX22230175

- 1) After mounting the cam sensor on the sensor bracket, insert it into the mounting holes in the cylinder block and tighten the bolts.

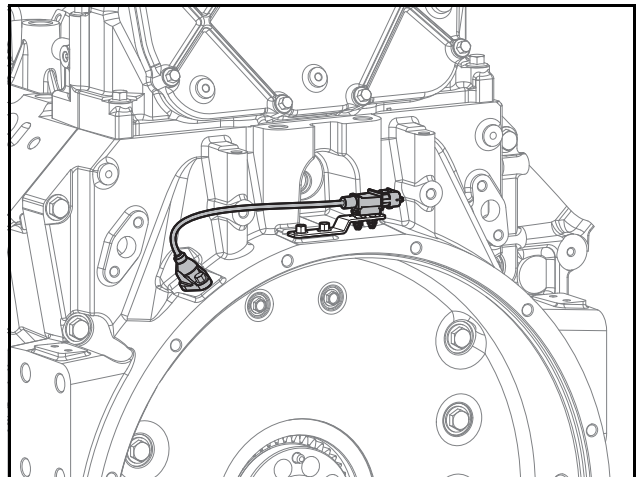

EDX15240067

- 2) After mounting the CRS sensor on the sensor bracket, insert it into the mounting holes in the flywheel housing and tighten the bolts.

Sensor & target wheel air gap	1.0 ±0.5 mm (0.0394 ±0.0197 in.)
-------------------------------	-------------------------------------

## 5. General Engine Information

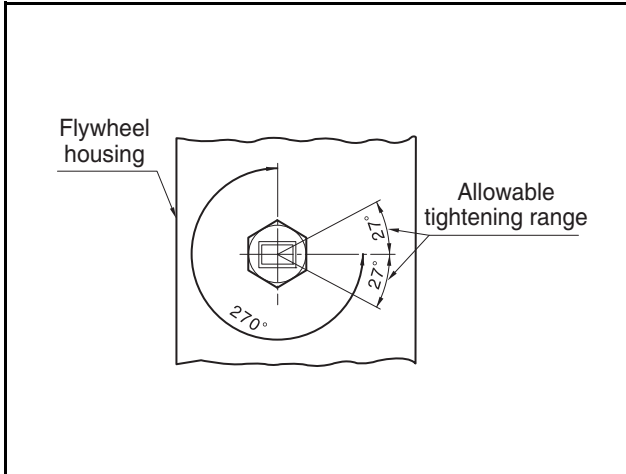

EPM20311

Sensor & target wheel air gap	1.0 ±0.5 mm (0.0394 ±0.0197 in.)
-------------------------------	-------------------------------------

### 8. Flywheel

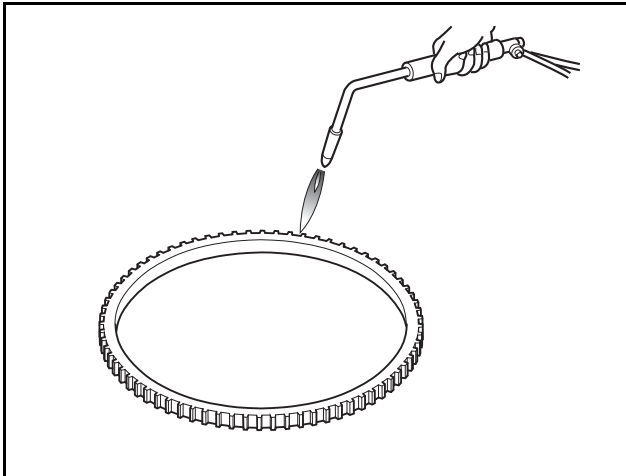

EA0M4029

- 1) Heat the ring gear evenly with a gas burner to expand it; then, use a hammer to install the ring gear on the flywheel.
- 2) Do not allow the temperature of the ring gear to exceed 200°C (392°F).

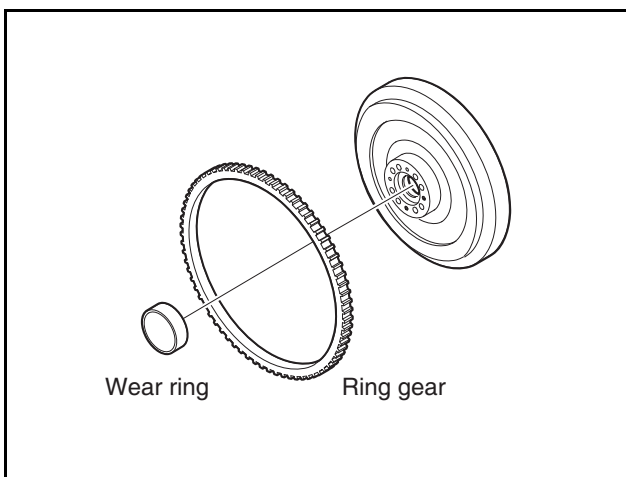

EA6M2004

- 3) Use an assembly jig to press fit the wear ring into the back of the flywheel so that the flywheel is aligned with the edge of the wear ring. (Apply Loctite #262 to the mounting surface)

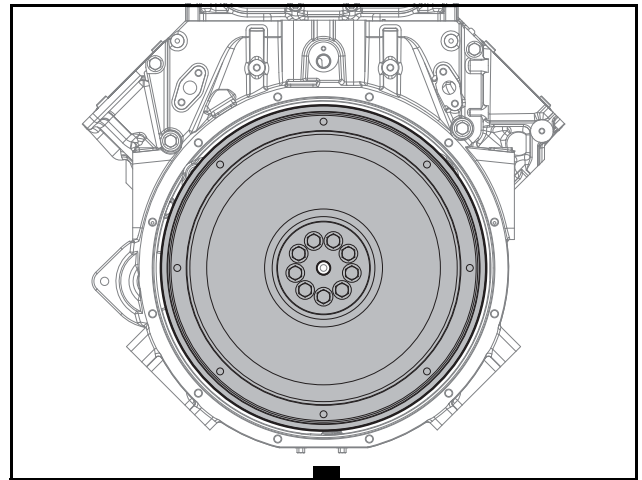

EDX15240059

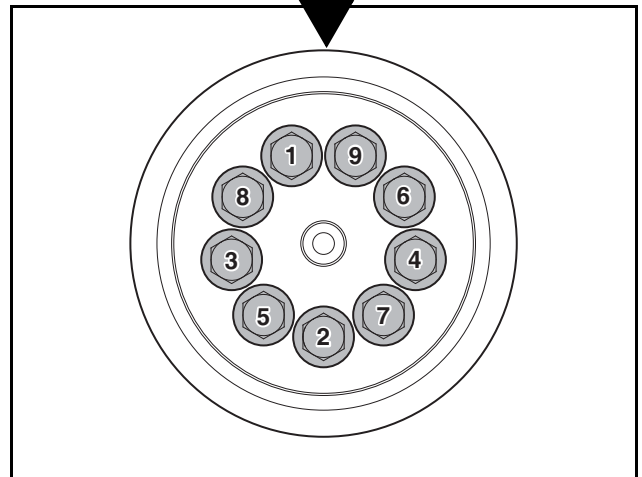

EDX22190117

- 4) Install the flywheel assembly guide bolts on the crankshaft.
- 5) Fit the flywheel onto the guide bolts and temporarily tighten the mounting bolts 2 ~ 3 threads; then, tighten the bolts to a torque of 20 kgf·m (144.66 lbf·ft) in the order of assembly.
- 6) After tightening the bolts again at an angle of 90° in the order of assembly, tighten them again at 90° in the order of assembly; finally, tighten them at 55° in order.

Torque	20 kgf·m (144.66 lbf·ft) + 90° + 90° + 55°
--------	---

## 5. General Engine Information

### 9. Oil seal holder (front)

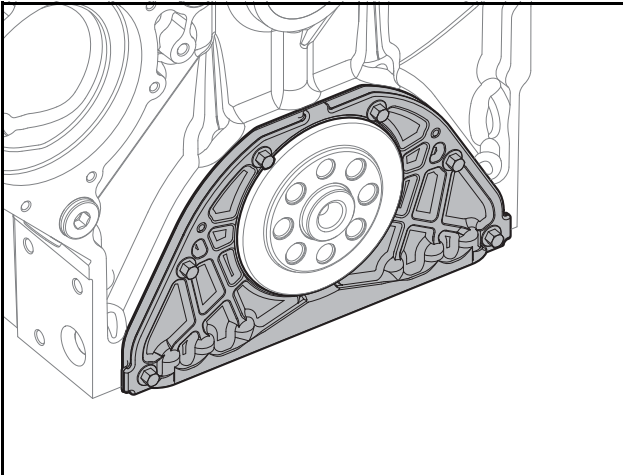

EDX22190093

- 1) After aligning the oil seal properly with the oil seal holder holes, use an insertion jig to install it. (Be careful not to damage the oil seal.)
- 2) Apply a gasket to the oil seal holder.
- 3) Align the cylinder block reference pins with the oil seal holder reference pin holes; then, tap the reference pins gently with a urethane hammer to assemble them. Make sure that the oil seal is not damaged by the crankshaft during assembly.

### **⚠ CAUTION**

**When inserting the oil seal into the oil seal holder, assemble it in a dry state without applying any oil or lubricant.**

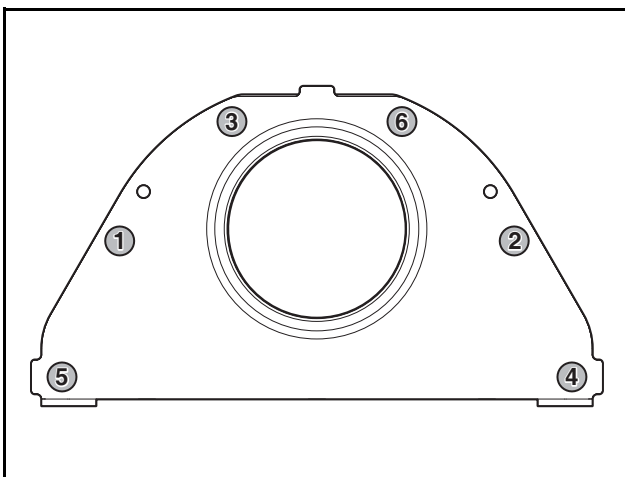

EDX22190118

- 4) Apply oil to the inside of the oil seal and tighten the oil seal holder in a zigzag pattern.

Torque	2.2 kgf·m (15.9126 lbf·ft)
--------	----------------------------

### 10. Pistons

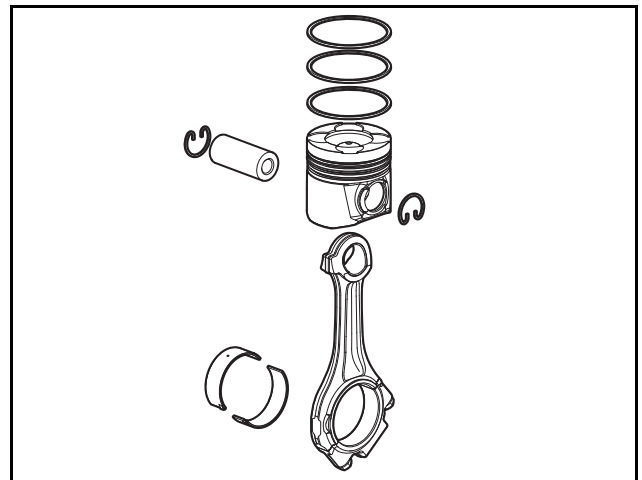

EDX22190120

- 1) Align the piston assemblies in order of their respective cylinders and insert the bearings into the connecting rods and bearing caps. Take care not to mix connecting rods and caps with those used in other cylinders.
- 2) Apply a sufficient layer of clean engine oil to the pistons and connecting rod bearings.

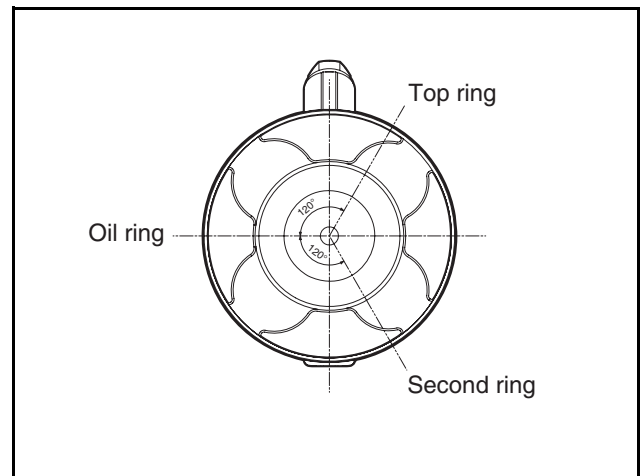

EDX22190119

- 3) Insert the piston rings with a special tool and adjust the gap between the piston rings to 120°.

## 5. General Engine Information

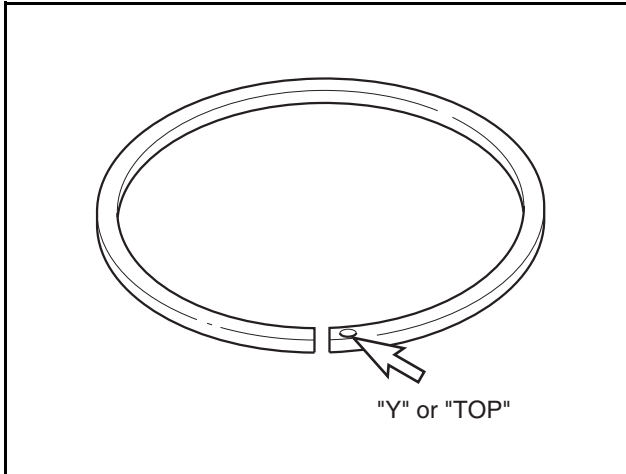

EAMD090I

- 4) Make sure not to install the piston rings upside down. The "Y" or "TOP" mark on top of the ring connection should face up.

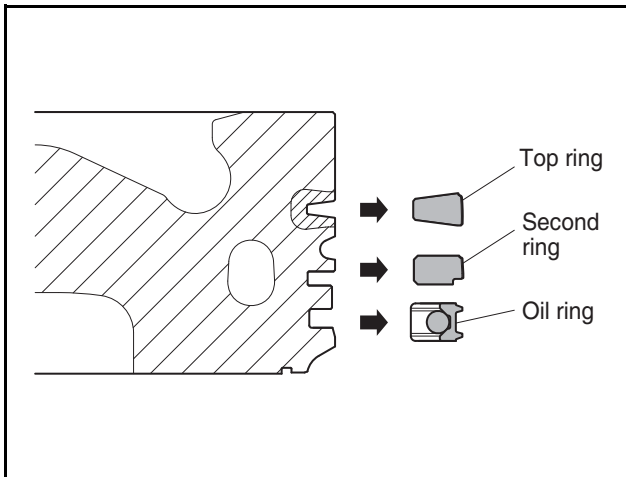

EE2OM071

- 5) Insert the pistons into the cylinders by hand or with a wooden stick.  
(Take care not to damage the piston and rings.)
- 6) Push the piston while rotating the crankshaft approx. 180° to install the bearing cap on the connecting rod.
- 7) Tighten the connecting rod bolts 2 ~ 3 threads; then, tighten them to the specified tightening torque (10 kgf·m (72.33 lbf·ft) + 90° + 10°).

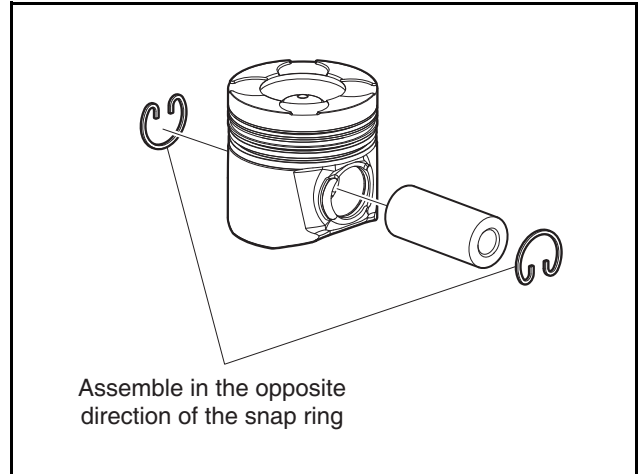

EDX22190121

### < Connecting rod bolt tightening sequence >

- Step 1: Tighten the bolts 2 ~ 3 threads by hand
- Step 2: Use a wrench to tighten them to approx. 7 kgf·m (50.6 lbf·ft)
- Step 3: Tighten them to 10 kgf·m (72.3 lbf·ft) with a torque wrench
- Step 4: Tighten them one last time to 90°+10° with the rotating angle method

Tighten the bolts in several stages according to the bolt tightening sequence above.

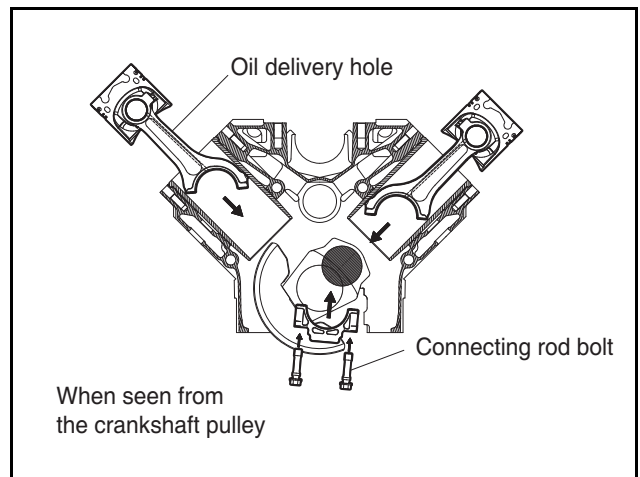

EE2OM073

- Standard bolt length and allowable limit  
From the seat of the head to the end of the bolt

Standard length	Allowable limit
67.5 <sup>-0.3</sup> mm (2.66 <sup>-0.012</sup> in.)	69 mm (2.7165 in.)

## 5. General Engine Information

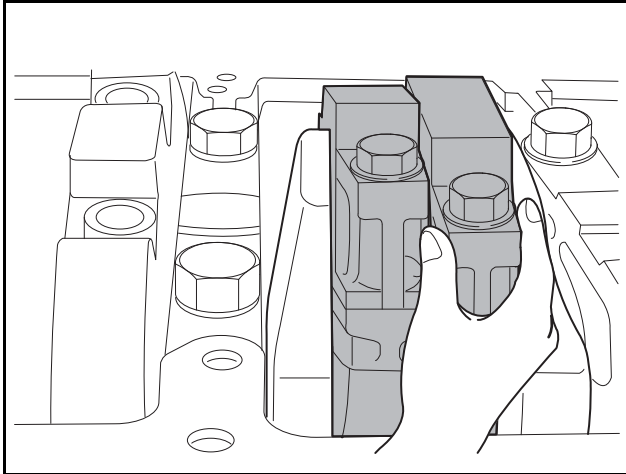

EFM2070I

- 8) Move the connecting rod bearing caps by hand to check whether they move smoothly from side to side.
- 9) Rotate the crankshaft in the same way as described above when mounting it on each cylinder.

### 11. Oil pump

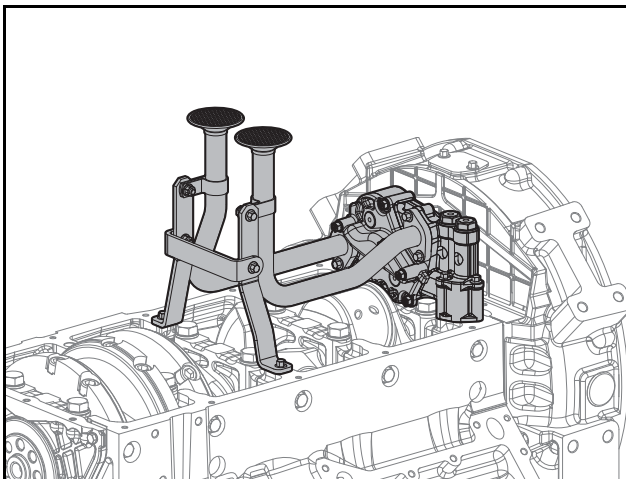

EDX15240056

- 1) Place the oil pump on the cylinder block mounting location.
- 2) Tighten the oil pump and pressure adjustment valve with mounting bolts to assemble them.

Oil pump backlash	0.035 ~ 0.263 mm (0.0014 ~ 0.0104 in.)
-------------------	---

- 3) Apply a gasket to the oil suction pipe mounting surface of the oil pump and tighten the oil suction pipe with mounting bolts to assemble it.
- 4) Tighten the pipe bracket onto the cylinder block with bolts to assemble it.

Torque	2.2 kgf-m (15.9126 lbf-ft)
--------	----------------------------

### 12. Vibration damper

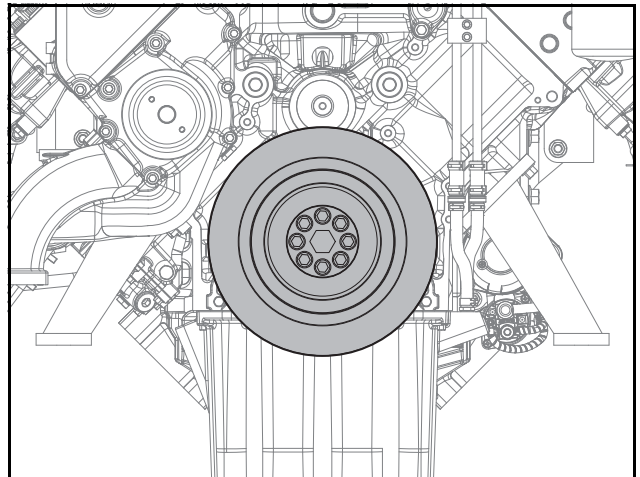

EDX15240039

- 1) Assemble the crankshaft pulley and vibration damper after first tightening them with mounting bolts.
- 2) Fit the crankshaft pulley assembly onto the crankshaft and apply engine oil to the bolts; then, tighten them to the specified torque.

Torque	21 kgf-m (151.893 lbf-ft)
--------	---------------------------

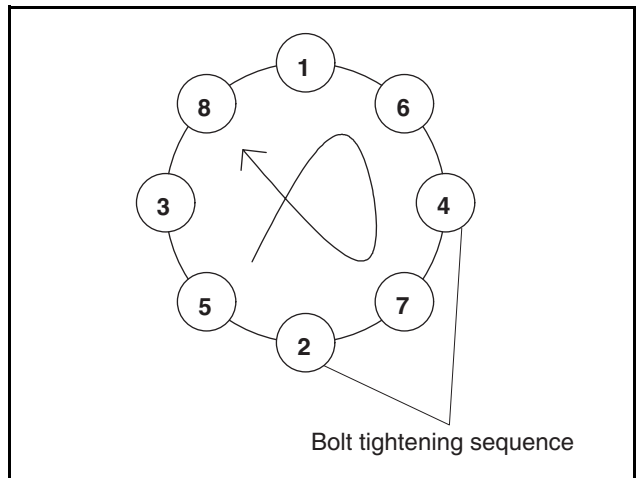

EE10M155

## 5. General Engine Information

### 13. Oil pan

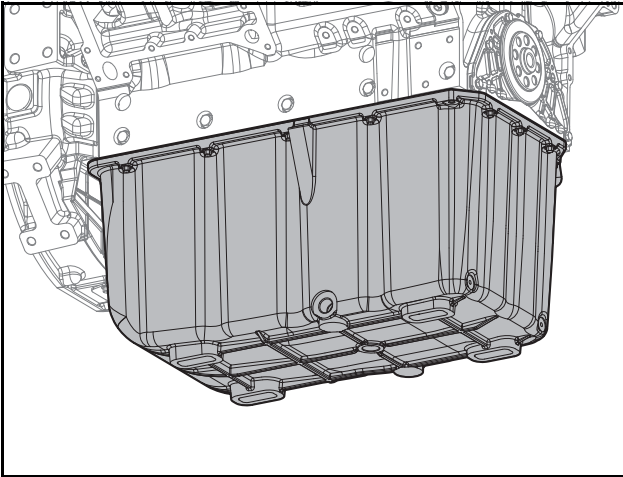

EDX15240055

- 1) Use a scraper to completely remove the gasket protruding from the joint between the front oil seal holder and the flywheel housing on the bottom of the cylinder block. When removing the gasket, make sure that pieces of the gasket do not enter the engine.
- 2) Apply a gasket to the cylinder block.
- 3) Mount the oil pan and tighten it with mounting bolts.
- 4) Take care not to displace the gasket.

Torque	Drain plug	15 kgf·m (108.495 lbf·ft) (M30-screw plug)
	Mounting bolts	3.1 kgf·m (22.4223 lbf·ft)

- 5) Mount the guide tube and insert the oil level gauge.

### 14. Intake and exhaust valves

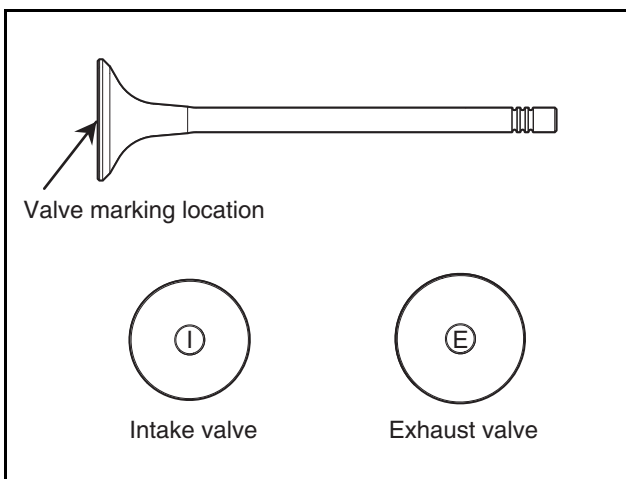

EDX22190122

- 1) Before installing the valves on the cylinder head, check the "I" and "E" marks on the valve head.
- 2) Use a valve stem seal installation jig to install the valve stem seals on the valve guides.

### 15. Cylinder Head

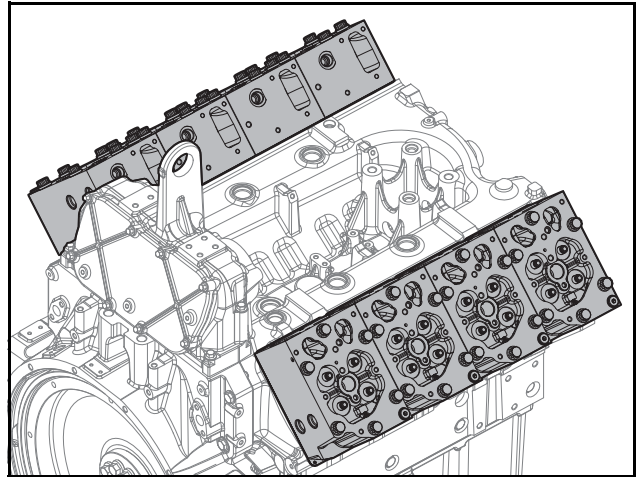

EDX15240054

- 1) Blow into the cylinder head bolt holes with compressed air to completely remove all foreign matter.
- 2) Thoroughly wipe the head gasket contact surface on the cylinder block.
- 3) Make sure to check for and remove any foreign matter in the combustion chamber.
- 4) Align the gasket with the cylinder block mounting pins and assemble it.
- 5) Align the cylinder head with the cylinder block reference pins and mount it on the cylinder block. (Be careful not to damage the head gasket.)

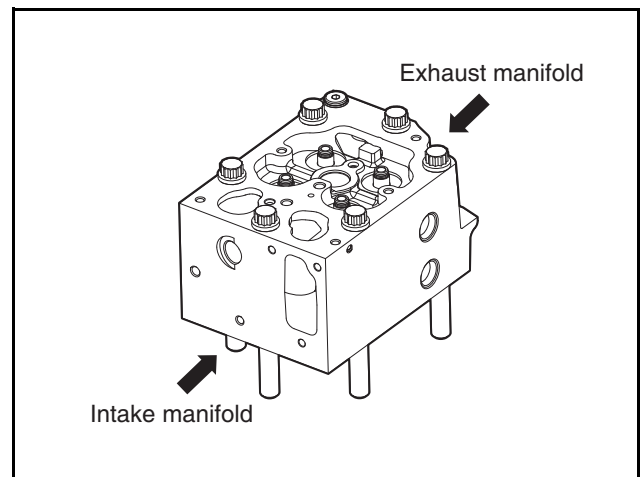

EDX22190123

## 5. General Engine Information

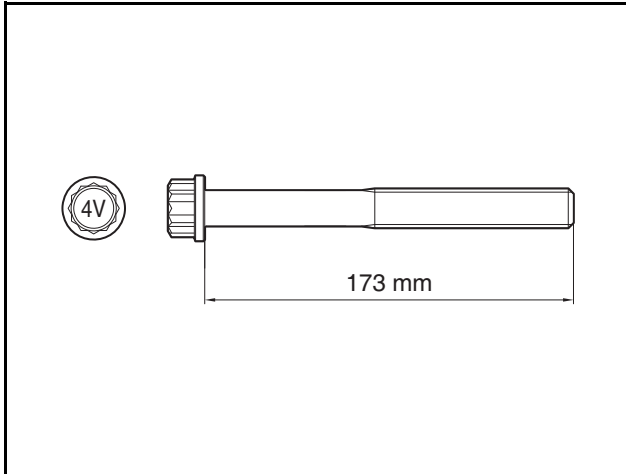

EF8OM072

- 6) Tighten the cylinder head bolts to the specified torque in several stages. Before assembling the bolts, make sure to adjust the parallelism between the cylinder head with a long steel ruler.

Standard length	173 mm (6.811 in.)
-----------------	--------------------

< Cylinder head bolt tightening sequence >

- Step 1: Tighten the bolts 1 ~ 2 threads by hand
- Step 2: Use a wrench to tighten them to approx. 4 kgf·m (28.9 lbf·ft)
- Step 3: Tighten them to 90° with the rotating angle method
- Step 4: Tighten them one final time by an additional 90°

### CAUTION

Take care not to allow any foreign matter to enter the cylinder head inlet passages.

## 16. Injectors

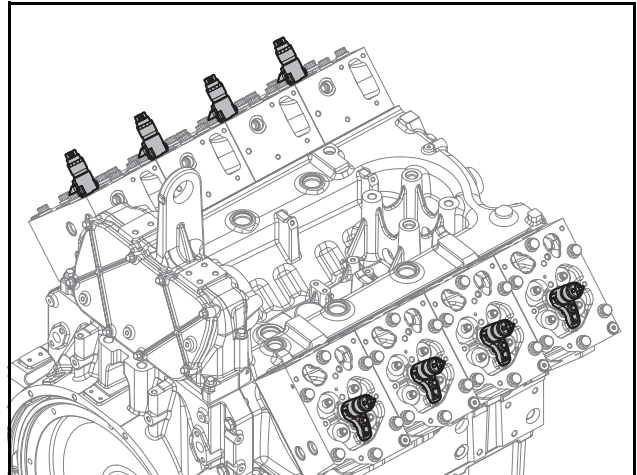

EDX15240053

### CAUTION

- When installing a new injection pipe after disconnecting the fuel injection pipe connected to a high-pressure fuel connector (HPC), make sure to retighten the HPC mounting nuts to the specified torque.
- In addition, do not reuse injection pipes as the sealing for high-pressure fuel is deformed while tightening the pipes.
  - Tightening torque of HPC nuts: 5.3 ±0.3 kgf·m (38.34 ±2.17 lbf·ft)
  - Tightening torque of injection pipes: 4.0 ±0.4 kgf·m (28.93 ±2.89 lbf·ft)
- Wash all parts thoroughly and keep them free of foreign matter.
- Fuel lines connecting the common rail to the injectors require particular cleanliness as they lack a filtration function.
- Clean and remove all foreign matter from the holes drilled in the cylinder head for inserting high-pressure fuel connectors and holes for injectors.
- When disassembling injectors, make sure to replace high-pressure fuel connectors with new ones.
- If fuel remaining in a fuel return line enters the combustion chamber while disassembling the injectors, it must be drained either with a hand pump or by cranking the starter motor with the fuel shut off.

## 5. General Engine Information

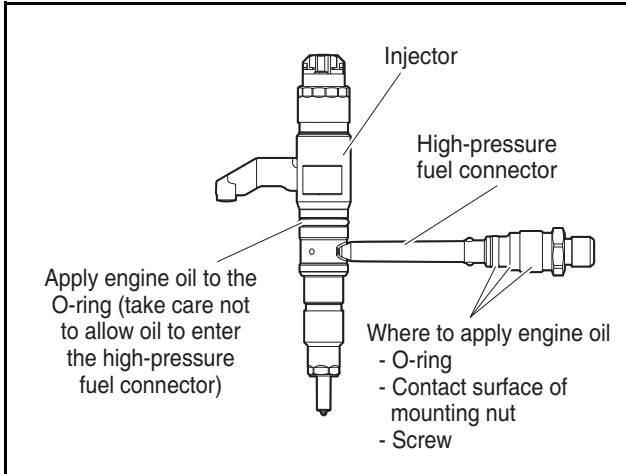

EDX22190099

- 1) The injectors must be assembled precisely in the following order.
- 2) Fit an O-ring onto the injector and apply engine oil to the outer circumference.

### **⚠ CAUTION**

**Be careful not to contaminate the connection hole in the high-pressure fuel connector on the side of the injector with oil or foreign matter.**

- 3) Insert the injector carefully after aligning the seal ring with the injector hole in the cylinder head. Align the injector mounting bolt with the threaded section on the head and turn the bolt two to three threads by hand to tighten it.
- 4) Seat the injector in the mounting position on injector mounting brackets ① and ② using the mounting bolts; then, tighten it temporarily. After tightening the injector temporarily, loosen the mounting bracket bolts enough to allow it to move without applying excessive force to the injector. (Injector axial load of 0 kg·m / 0 lbf-ft)

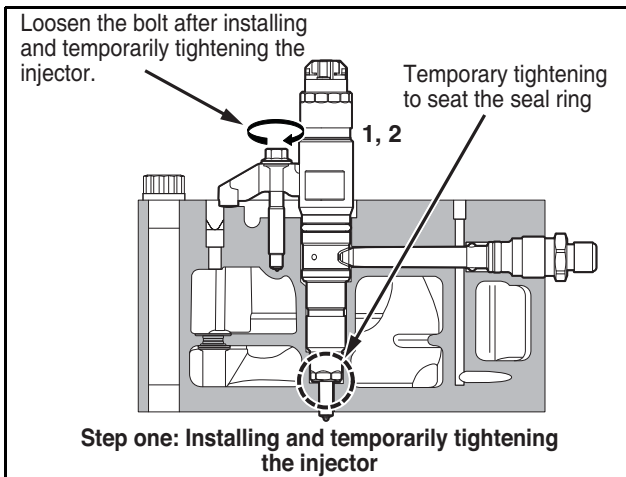

EDX22190100

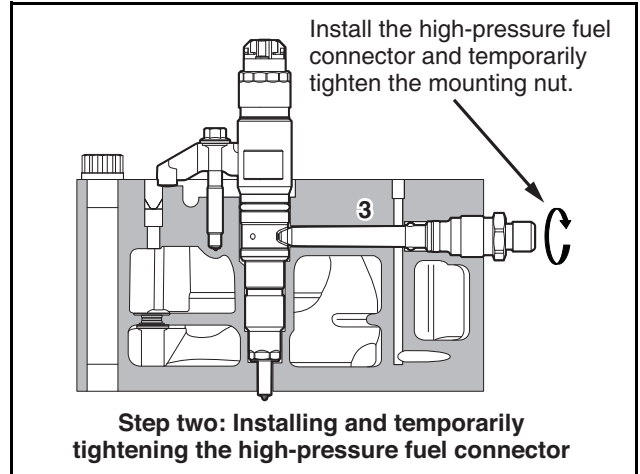

EDX22190238

- 5) Hold the ball on high-pressure fuel connector ③ in the vertical position and check that it is aligned with the groove in the hole on the side of the head of the intake manifold; then, align it with the high-pressure fuel connector using the hole in the side of the head and push the high-pressure fuel connector in as far as possible. After tightening the mounting nut (M22 × 1.5) on the high-pressure fuel connector two to three threads by hand, use a torque wrench to tighten it temporarily.

Temporary tightening torque	Injector mounting bracket bolt	High-pressure fuel connector Mounting nut
	0.3 ±0.1 kgf·m (2.17 ±0.7233 lbf-ft)	0.3 ±0.1 kgf·m (2.17 ±0.7233 lbf-ft)

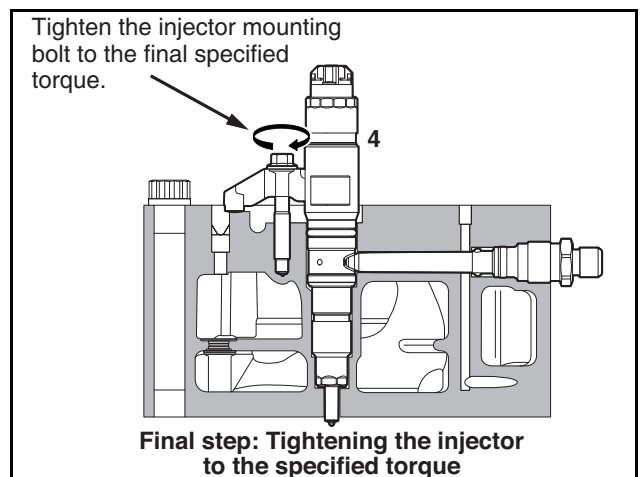

EDX22190239

## 5. General Engine Information

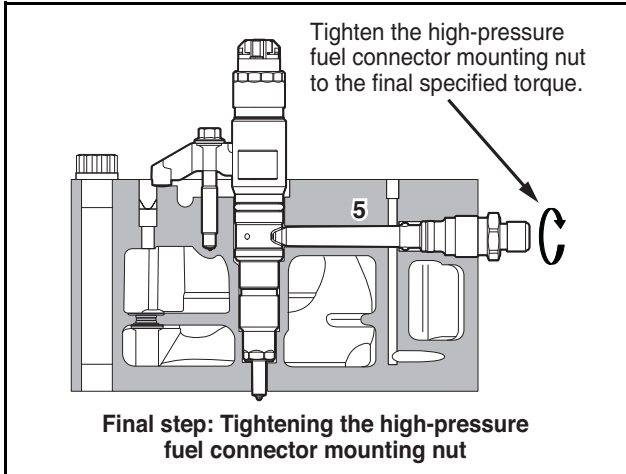

EDX22190136

- 6) Finish tightening injector mounting bracket mounting bolt ④ and high-pressure fuel connector mounting nut ⑤ to their specified torque in order.

Final Torque	Injector mounting bracket bolt	High-pressure fuel connector Mounting nut
		3.0 ±0.5 kgf·m (21.699 ±3.62 lbf·ft)

### 17. Rocker arms

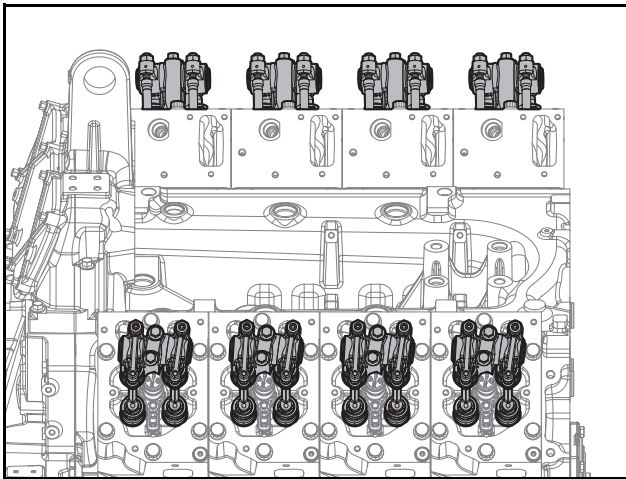

EDX15240052

- 1) Apply engine oil to the pushrod and insert it into the pushrod hole.
- 2) Mount the rocker arm assemblies on the cylinder head and tighten the mounting bolts to the specified torque.

Torque	6.2 kgf·m (44.8447 lbf·ft)
--------	----------------------------

### 18. Flywheel housing cover

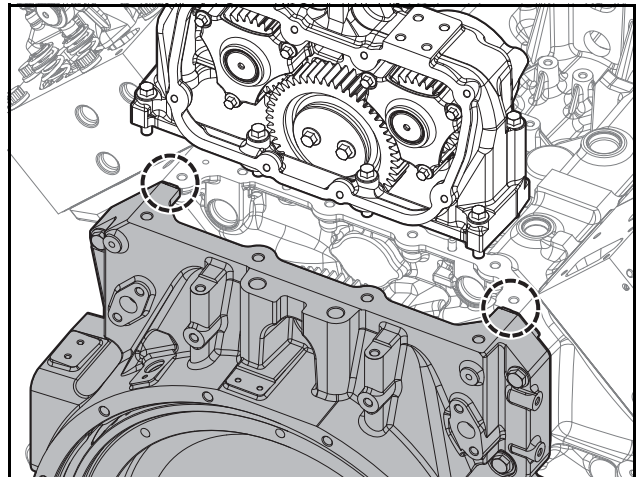

EDX15240068

- 1) Apply a liquid gasket to the T-joint between the cylinder block and the flywheel housing.

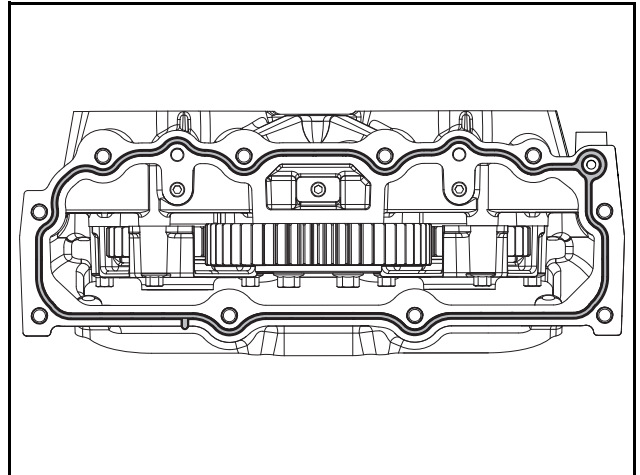

EDX22230149

- 2) After checking the rubber gasket on the timing gear case, seat it on the mounting surface; then, tighten the mounting bolts in a zigzag pattern.

Torque	6.2 kgf·m (44.8447 lbf·ft)
--------	----------------------------

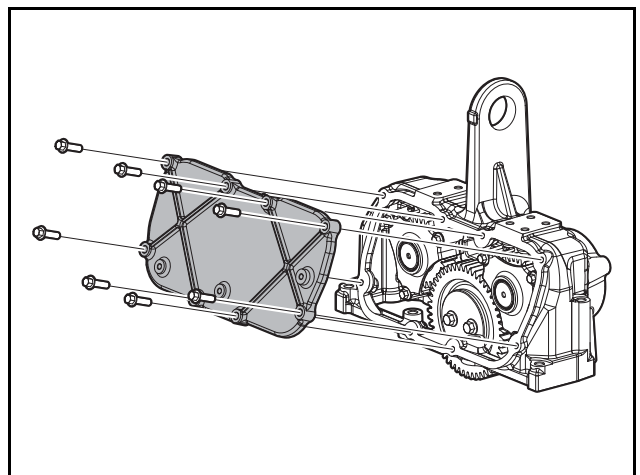

EDX22230188

## 5. General Engine Information

- 3) After installing the timing gear case, install the cover (8-M8 X 1.25).

Torque	2.2 ±0.55 kgf·m (15.91 ±3.9782 lbf·ft)
--------	---

### 19. Fuel injection pump

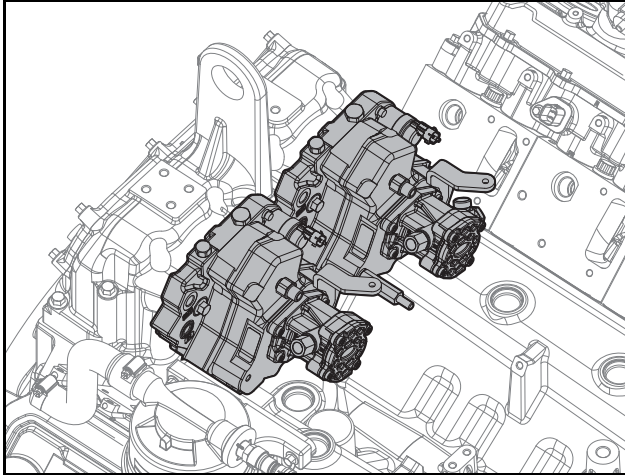

EDX15240050

- 1) After greasing the O-ring on the high-pressure fuel pump, align the drive gear spline teeth on the timing gear case and insert it. (Assemble the spline teeth and high-pressure pump teeth regardless of the timing.)
- 2) After inserting the high-pressure pumps on both sides, assemble the mounting bolts.

### 20. Oil cooler

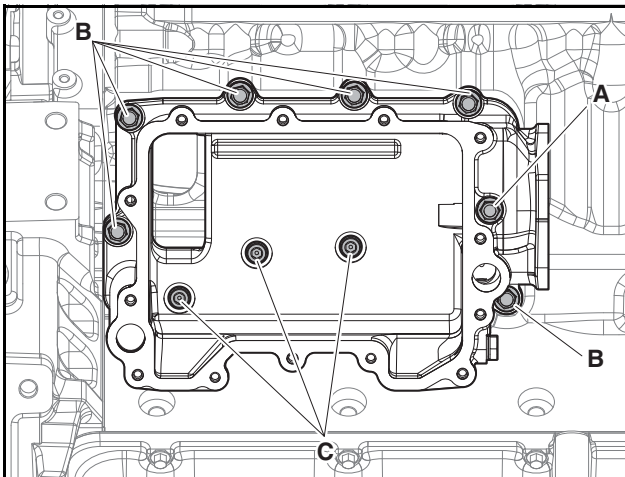

EDX15240069

- 1) Apply gaskets (B) to the surface of the oil cooler housing where the oil cooler is to be installed.
- 2) Tighten the oil cooler with the mounting bolts.
- 3) Tighten and assemble the oil cooler mounting bolts in a zigzag pattern.

- Oil cooler housing mounting bolts and torque

Torque	M10 hex bolt (A)	6.2 ±1.55 kgf·m (44.8447 ±11.2112 lbf·ft)
	M10 hex bolt (B)	6.2 ±1.55 kgf·m (44.8447 ±11.2112 lbf·ft)
	M10 wrench bolt (C)	6.2 ±1.55 kgf·m (44.8447 ±11.2112 lbf·ft)

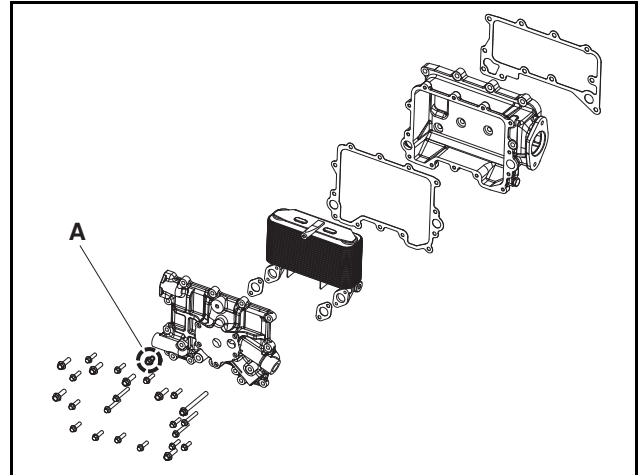

EDX15240070

- 4) Tighten the oil cooler and cover with mounting bolts.
- 5) Install washers and apply Loctite to 1 cover mounting bolts (A); then, tighten them.

- Oil cooler and cover mounting bolts

Torque	M8 hex bolt	2.2 ±0.4 kgf·m (15.91 ±2.89 lbf·ft)	1 EA (A)
		3.1 ±0.3 kgf·m (22.42 ±2.17 lbf·ft)	12 EA

### 21. Oil Filter

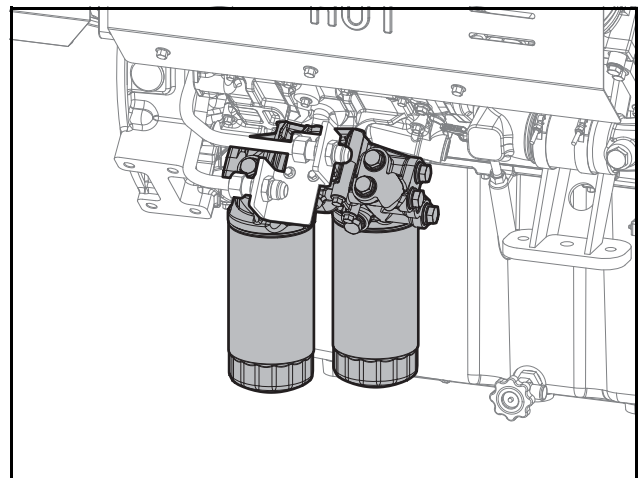

EDX15240025

- 1) Apply a gasket to the oil cooler housing surface and assemble the oil filter.
- 2) Install the oil filter cartridge.

## 5. General Engine Information

M10 hex bolt

6.2 kgf·m (44.8447 lbf·ft)

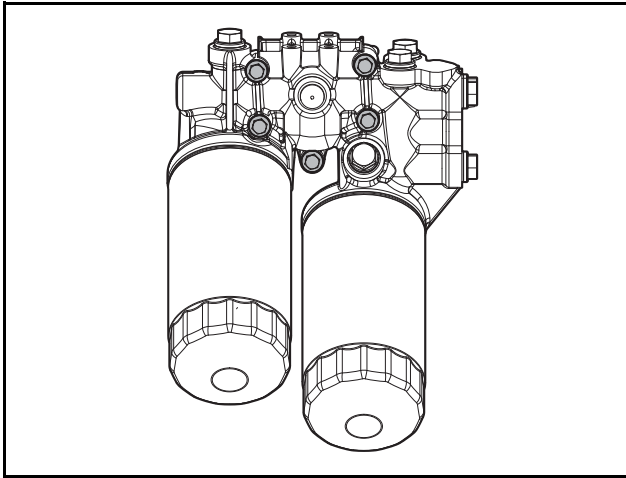

EDX15240038

### 3) Cartridge

- a) Apply engine oil to the rubber packing.
- b) Tighten the packing until it comes into contact with the filter head.
- c) Use a filter wrench to tighten it another 3/4 ~ 1 turns.

Note) Do not forget to tighten the drain plug after draining the engine oil.

- Use a filter wrench to turn and loosen the oil filter in the counterclockwise direction.
- Use a rag wipe to clean the filter body and mounting surface of the oil filter body and ensure that the new oil filter cartridge is seated properly.
- Lubricate the O-ring lightly with oil and turn the oil filter until the sealing surface aligns with the O-ring. Use a filter wrench to turn it an additional 1-1/4 turns.

Torque

4.4 kgf·m (31.8253 lbf·ft)

### 22. Coolant pump

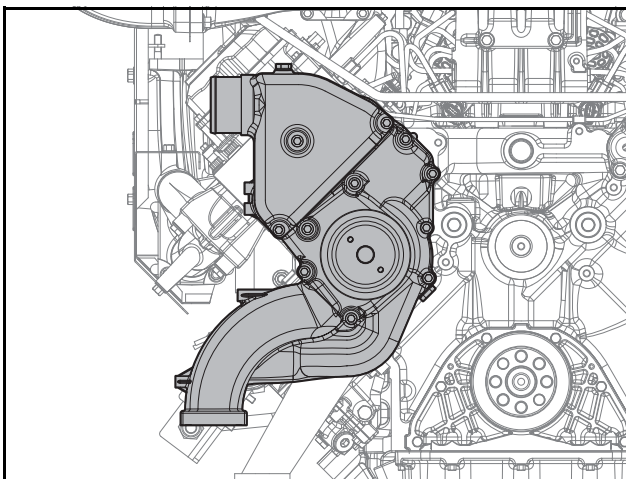

EDX15240040

- 1) When applying a gasket to the coolant pump, apply a sealant to the surface of both the gasket and the cylinder block.

- Coolant pump and coolant pipe

Torque

M8

2.2 kgf·m (15.91 lbf·ft)

- 2) Tighten and assemble the coolant pump with mounting bolts in a zigzag pattern.
- 3) Fit the thermostat onto the coolant pump.
- 4) Fit an O-ring onto the thermostat and tighten the coolant pipe with mounting bolts to assemble it.

### 23. Starter Motor

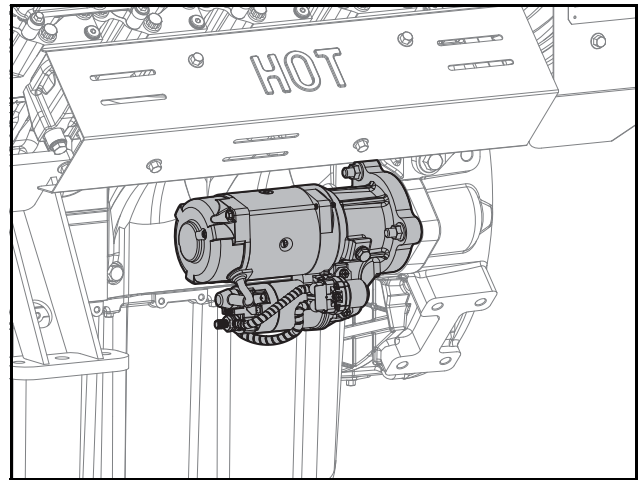

EDX15240041

- 1) Tighten stud bolts in the starter motor mounting holes in the flywheel housing.
- 2) Fit the starter motor onto the flywheel housing and tighten it with mounting nuts.

Torque

8 kgf·m (57.8641 lbf·ft)

### 24. Cylinder head cover and middle cover

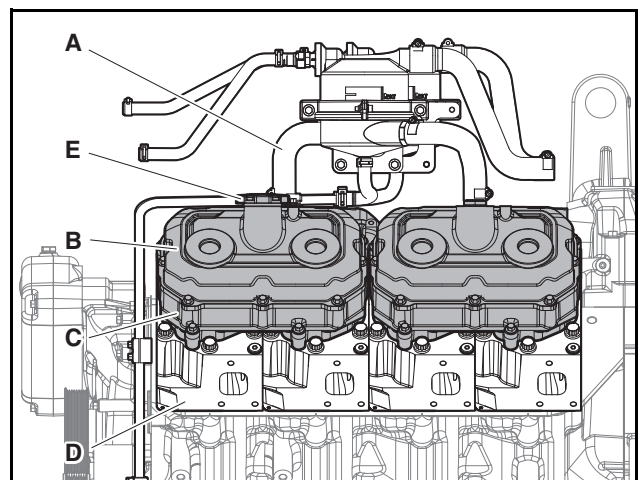

EDX15240071

- 1) After applying a new gasket to the middle cover mounting surface of cylinder head (D), tighten it with mounting bolts to assemble it.

## 5. General Engine Information

- 2) Tighten cylinder head cover (B) with mounting bolts to assemble it.
- 3) Insert oil filler cap (E).
- 4) Insert oil breather hose (A) and tighten it with a clamp to assemble it.

Middle cover (C) and head cover (B) mounting bolt torque	2.2 kgf·m (15.9126 lbf·ft)
--	-------------------------------

### 25. Intake manifold

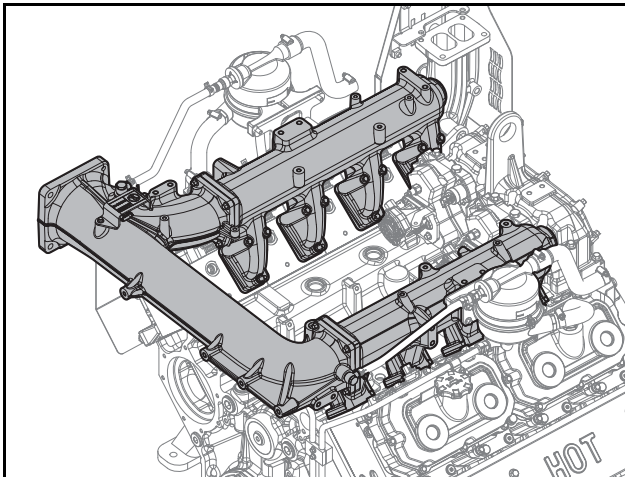

EDX15240046

- 1) Apply a new gasket to the cylinder head surface.
- 2) Tighten the intake manifold with mounting bolts to assemble it.

Torque	2.2 kgf·m (15.9126 lbf·ft)
--------	----------------------------

### 26. Fuel injection pipe

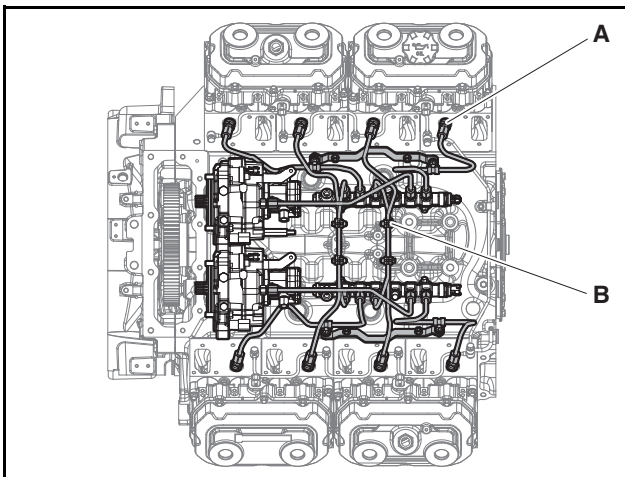

EDX15240072

- 1) Connect the high-pressure pipes between high-pressure fuel connectors (A) and the common rail, and fasten them with clips (B).

High-pressure fuel pipe nut torque	4 kgf·m (28.9 lbf·ft)
------------------------------------	-----------------------

### < Fuel pipe assembly order >

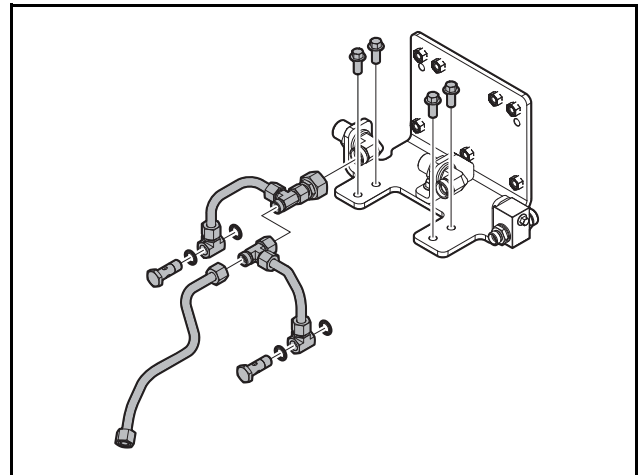

EDX22230151

- Tighten the sub adapter with four bolts.

Torque	6.2 kgf·m (44.8447 lbf·ft)
--------	----------------------------

- Tighten the hollow screws on three fuel pipes three to four threads by hand temporarily.
- Tighten the cap nuts on three fuel pipes three to four threads by hand temporarily.
- Tighten two hollow screws completely.

Torque	2.5 kgf·m (18.0825 lbf·ft)
--------	----------------------------

- Tighten the cap nuts completely. (After tightening the pipes temporarily, tighten them with the rotating angle method (120° ±30°))

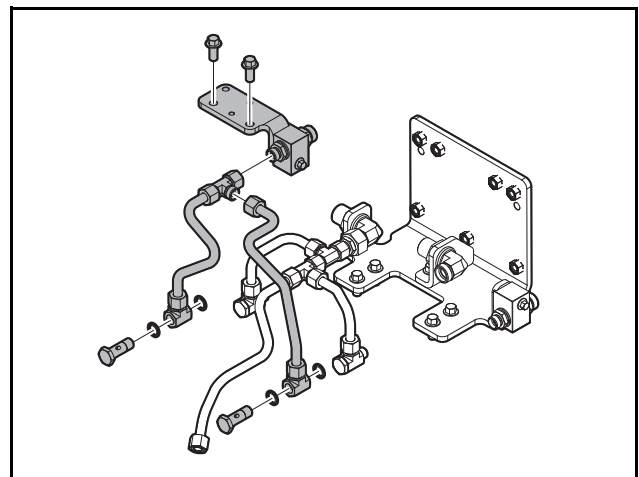

EDX22230152

- Tighten two bolts on the sub bracket.

Torque	6.2 kgf·m (44.8447 lbf·ft)
--------	----------------------------

- Tighten the hollow screws on two fuel pipes three to four threads by hand temporarily.
- Tighten the cap nuts on two fuel pipes three to four threads by hand temporarily.
- Tighten two hollow screws completely.

## 5. General Engine Information

Torque	2.5 kgf-m (18.0825 lbf-ft)
--------	----------------------------

- Tighten the cap nuts completely. (After tightening the pipes temporarily, tighten them with the rotating angle method ( $120^\circ \pm 30^\circ$ ))

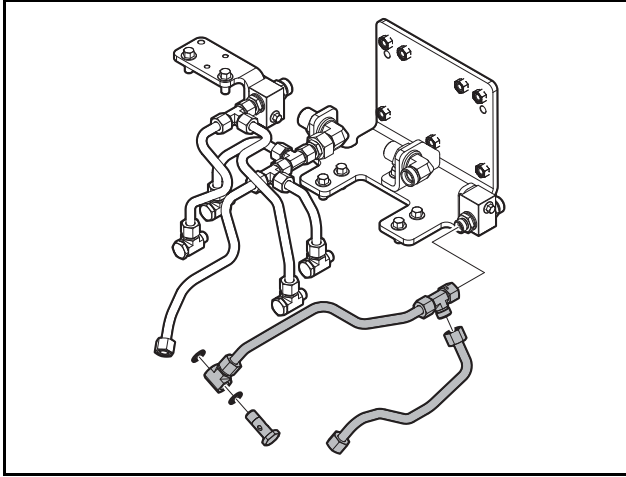

EDX22230153

- Tighten the hollow screws on two fuel pipes three to four threads by hand temporarily.
- Tighten the cap nuts on two fuel pipes three to four threads by hand temporarily.
- Tighten one hollow screw completely.

Torque	2.5 kgf-m (18.0825 lbf-ft)
--------	----------------------------

- Tighten the cap nuts completely. (After tightening the pipes temporarily, tighten them with the rotating angle method ( $120^\circ \pm 30^\circ$ ))

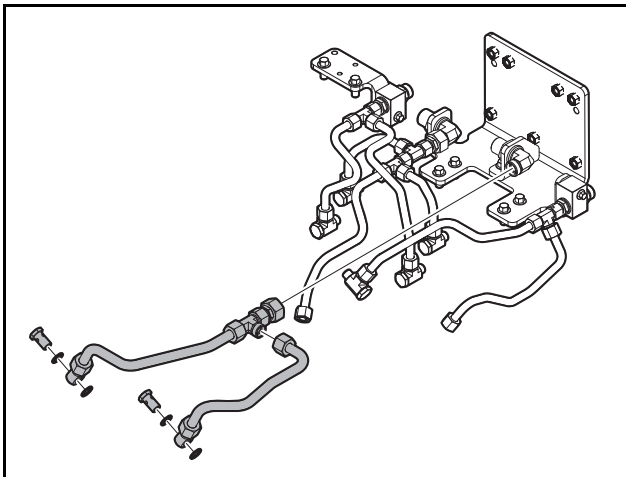

EDX22230154

- Tighten the hollow screws on two fuel pipes three to four threads by hand temporarily.
- Tighten the cap nuts on two fuel pipes three to four threads by hand temporarily.
- Tighten two hollow screws completely.

Torque	2.5 kgf-m (18.0825 lbf-ft)
--------	----------------------------

- Tighten the cap nuts completely. (After tightening the pipes temporarily, tighten them with the rotating angle method ( $120^\circ \pm 30^\circ$ ))

### 27. Exhaust manifold

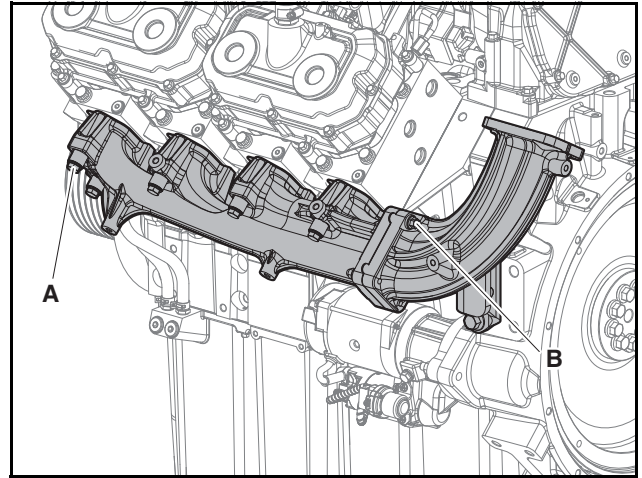

EDX15240073

- Connect the two-part exhaust manifold by fitting a steel ring onto the connection.
- Apply a new gasket to the exhaust manifold.

Torque	Manifold mounting bolts (A)	8 kgf-m (57.8641 lbf-ft)
	Exhaust elbow mounting nuts (B)	6.6 kgf-m (47.7379 lbf-ft)

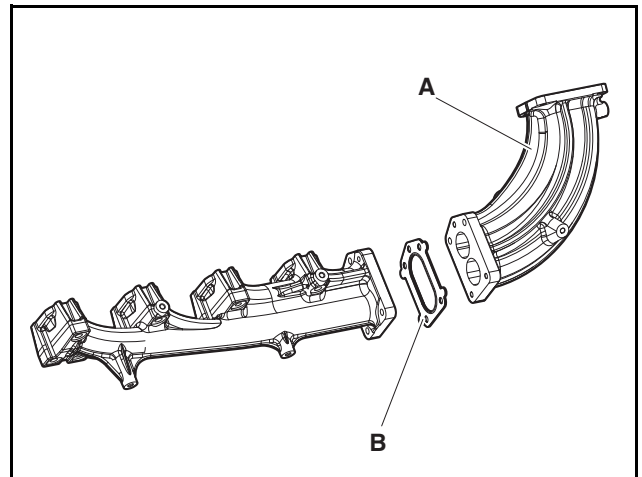

EDX15240074

- Apply gasket (B) to exhaust elbow (A) connected to the exhaust manifold and tighten the connecting nuts to assemble it.
- Assemble both sides as described above.

Torque	Manifold mounting bolts (A)	8 kgf-m (57.8641 lbf-ft)
	Exhaust elbow mounting nuts (B)	6.6 kgf-m (47.7379 lbf-ft)

## 5. General Engine Information

### 28. Turbocharger

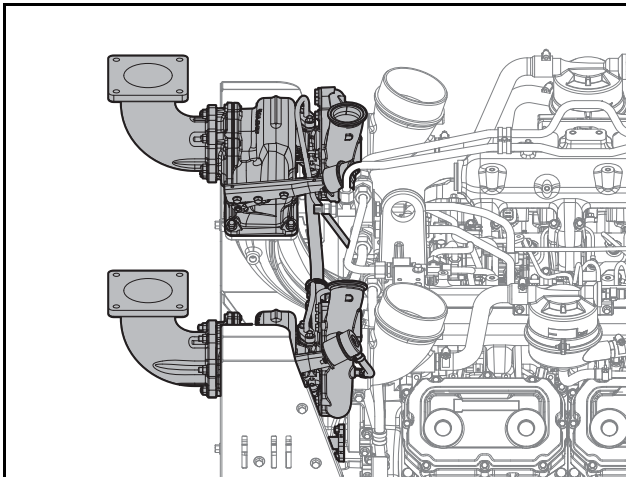

EDX15240034

- 1) Apply a gasket to the exhaust elbow and assemble the turbocharger with mounting clamps.
- 2) Apply a gasket to the oil delivery pipe and tighten the mounting bolts to assemble it.
- 3) Apply a gasket to the oil drain pipe and tighten the bolts to assemble it.
- 4) Assemble both sides as described above.

Torque	Turbocharger mounting clamp	6.6 kgf·m (47.7379 lbf·ft)
	Oil supply pipe	2.2 ±0.2 kgf·m (15.9126 ±1.4466 lbf·ft)
	Clamp	1.2 ±0.1 kgf·m (8.6796 ±0.7233 lbf·ft)

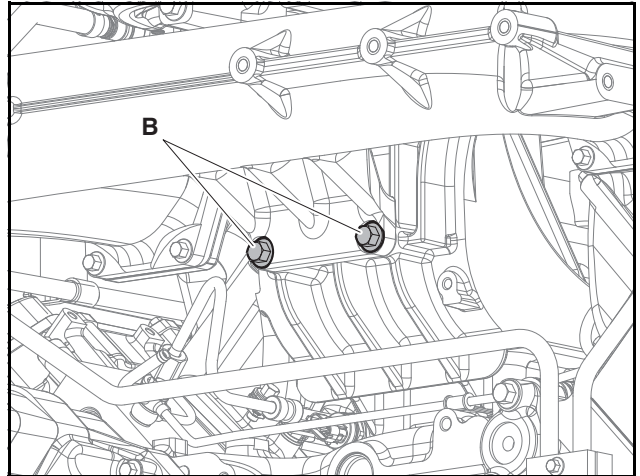

EDX15240076

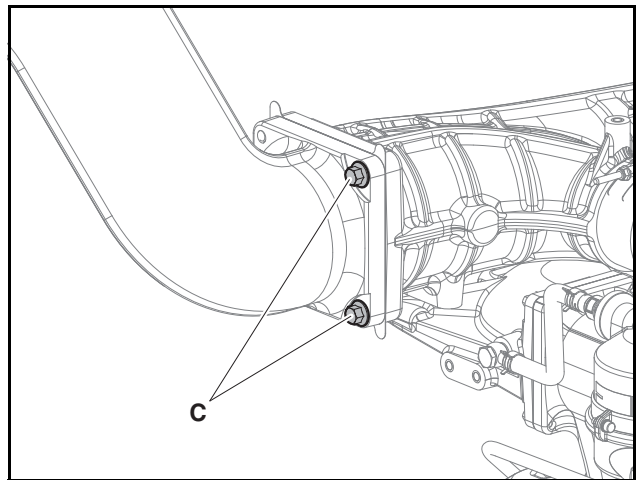

EDX15240077

### 29. Intake stake and air pipe

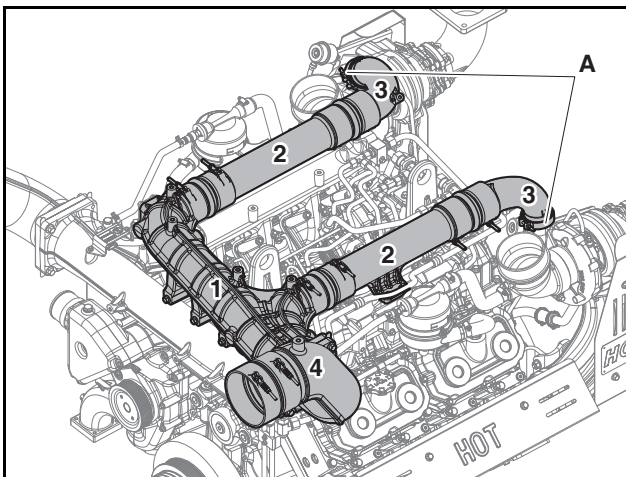

EDX15240075

- 1) Tighten the intercooler pipes (1) with mounting bolts.
- 2) Assemble air pipes (2, 3) with intercooler pipe (1) sequentially; then, align them with the turbocharger outlet and tighten them with clamps.
- 3) Tighten elbow pipe (4) and a new gasket onto intercooler pipe (1) with mounting bolts.

Torque	Clamp torque (A)	1.2 kgf·m (8.6796 lbf·ft)
	Intercooler pipe M10 (B)	6.2 kgf·m (44.8447 lbf·ft)
	Elbow pipe torque M12 (C)	6.2 kgf·m (44.8447 lbf·ft)

### CAUTION

The seal rings installed in two places on assemblies no. 1 and no. 2 and assemblies no. 2 and no. 3 as described above are a guide strap and O-ring.

Make sure that the guide strap and O-ring do not fall off or get crushed.

## 5. General Engine Information

### 30. Hose and pipe

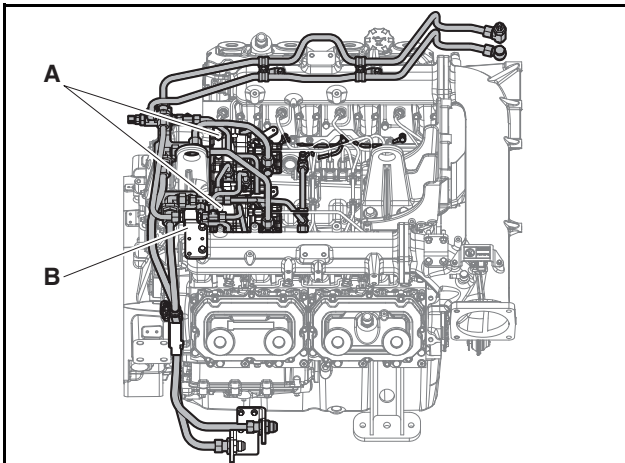

EDX15240043

- 1) Mount the pipe adapter and bracket and connect the fuel delivery and return pipes.
- 2) Connect the low-pressure fuel pipes between fuel pumps (A) and junction block (B).

### 31. Fuel filter

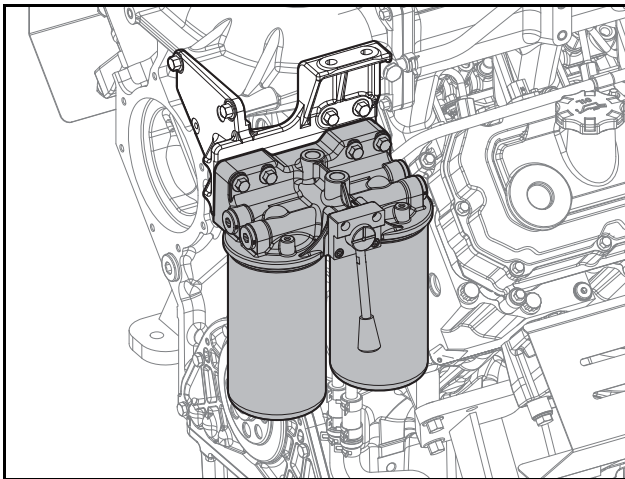

EDX15240098

- 1) Secure the bracket on the cylinder block and assemble the fuel filter.
- 2) When replacing the fuel filter with a new one, make sure to fill the cartridge inside with fuel before installing it.

Torque	4 kgf·m (28.9 lbf·ft)
--------	-----------------------

### 32. Alternator

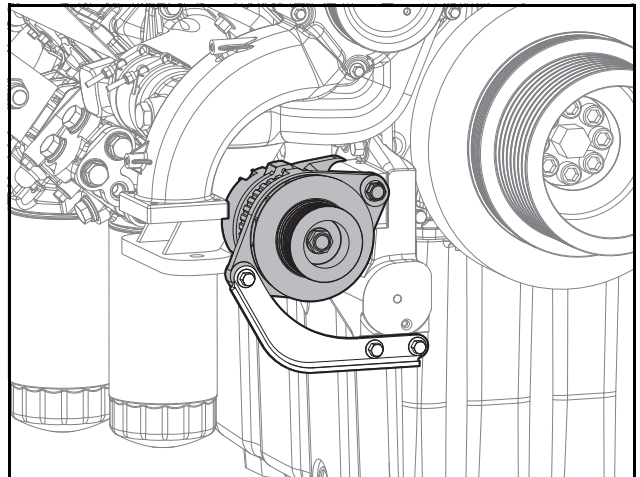

EDX15240032

- 1) Tighten the alternator bracket onto the cylinder block with mounting bolts to assemble it.
- 2) Mount the alternator on the bracket and fasten it with the lower bracket.
- 3) Mount the auto tensioner, connect the V-belt to the crankshaft, coolant pump, and alternator pulley; then, insert a wrench into the tensioner pulley and turn it counterclockwise to mount the V-belt.

### 33. Idler pulley and belt

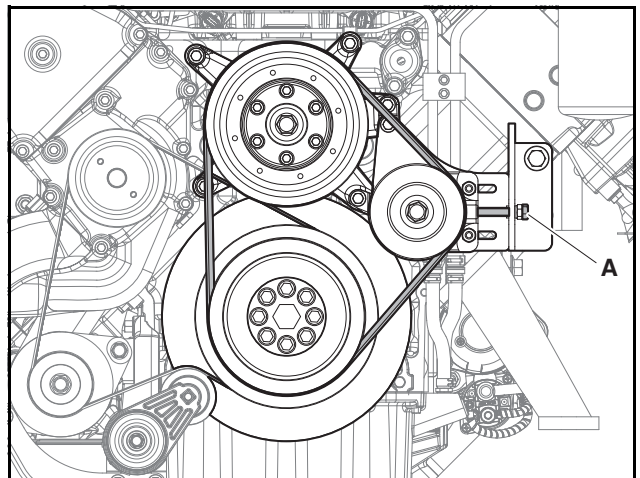

EDX15240078

- 1) Mount the idler pulley.
- 2) Connect the fan pulley, crank pulley, and idler pulley with the V-belt.
- 3) Tighten tension adjustment bolt (A) of the idler pulley. (Belt tension: 415 N/each, 3320 N/total)

## 5. General Engine Information

---

### 34. Cooling fan and fan drive

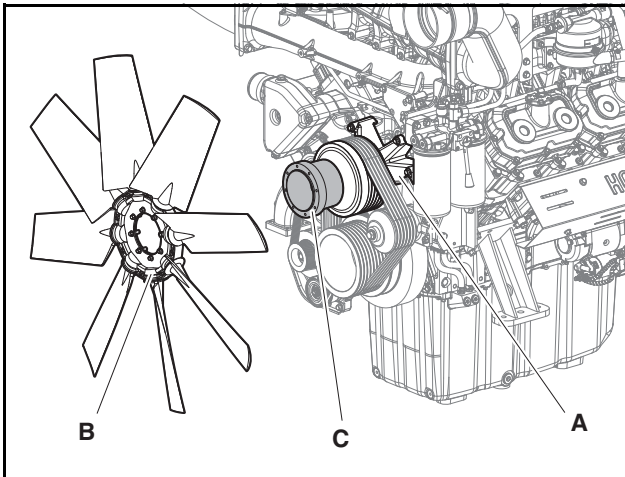

EDX15240079

- 1) Install fan drive bracket (A) on the cylinder block and assemble the fan.
  - 2) Assemble cooling fan (B) and fan flange (C) with mounting bolts; then, tighten them to the specified torque.
35. Oil level gauge and guide tube

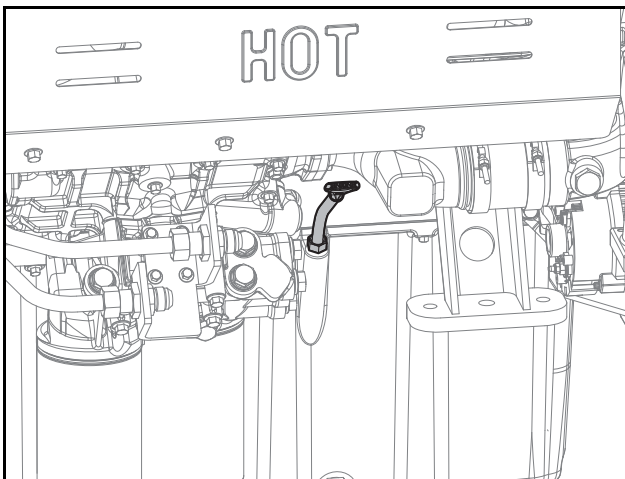

EDX15240026

- 1) Assemble the guide tube and oil level gauge with the oil pan.
36. Misc.
- 1) Connect the various sensors, harnesses, fuel and oil lines.

# 6. Cooling System

Overview and Specifications .....	87
Overview .....	87
Specifications .....	88
Thermostat .....	89
General Information .....	89
Inspection .....	89
Cautions for Replacing and Handling the Thermostat .....	89
Causes of Faults and Troubleshooting .....	90
Air Heater (Optional) .....	91
Operating Conditions .....	91
Circuit Diagram .....	91



### Overview and Specifications

#### Overview

This engine is water-cooled. After coolant absorbs combustion heat from the combustion chamber and heat from engine oil, it releases the heat externally to ensure normal engine operation.

In the cooling system, coolant supplied from the coolant pump flows to the oil cooler through the coolant pipe to absorb heat from oil. Then, as it passes through the coolant jacket of the cylinder block and the cooling passage of the cylinder head, it absorbs combustion heat.

Then, this coolant is conveyed to the thermostat through the coolant pipe. If the coolant temperature is lower than the valve opening temperature of the thermostat, it is returned to the coolant pump. Otherwise, it flows to the radiator. In the radiator, the heat absorbed by the coolant is released and the coolant returns to the coolant pump.

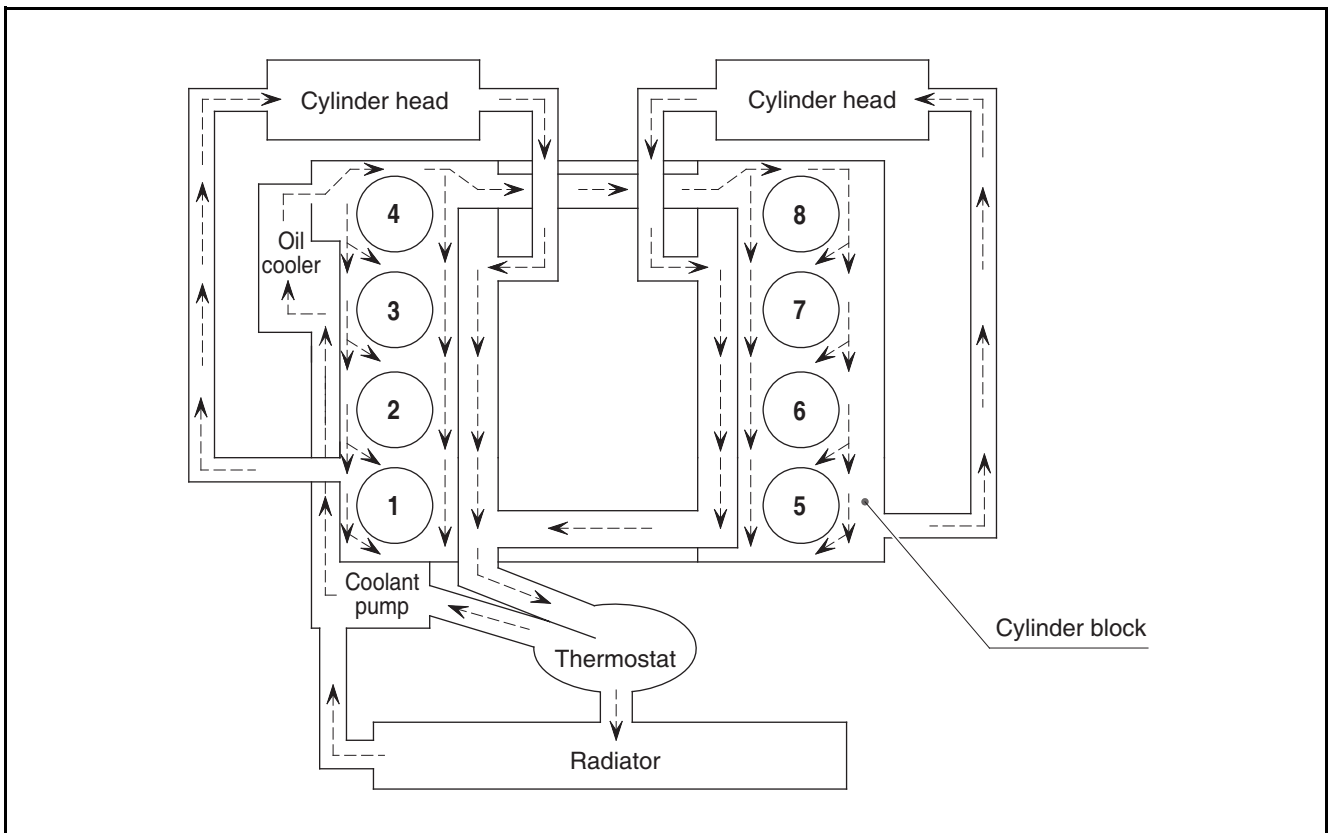

EDX15240081

## 6. Cooling System

---

### Specifications

Item		Specifications
Coolant pump	Type	Centrifugal
	Supply	Approx. 840 liter/min. (221.9 gal./min.)
	Pump speed	3,500 rpm
	Pump back pressure	1.8 kg/cm <sup>2</sup> (25.6 psi)
Thermostat	Operating temperature	71 ~ 85°C (160 ~ 185°F)
Cooling fan and belt	Fan diameter - number of blades	Ø1,150 mm (45.28 in.) - 8
	Belt tension	415 N/each, 3320 N/total

## Thermostat

### General Information

The thermostat is used to maintain a constant coolant temperature and prevent heat loss in order to enhance the engine's thermal efficiency.

When the coolant temperature is low, the thermostat valve closes and coolant is bypassed directly to the pump. When the coolant temperature rises and the thermostat valve opens completely, the bypass circuit closes and the coolant passage to the radiator opens to allow coolant to flow to the radiator.

Item	Specifications
	Temperature regions
Type	Wax pellet
Opening temp.	71°C (160°F)
Fully open temp.	85°C (185°F)
Valve lift	8 mm (0.31 in.) or more

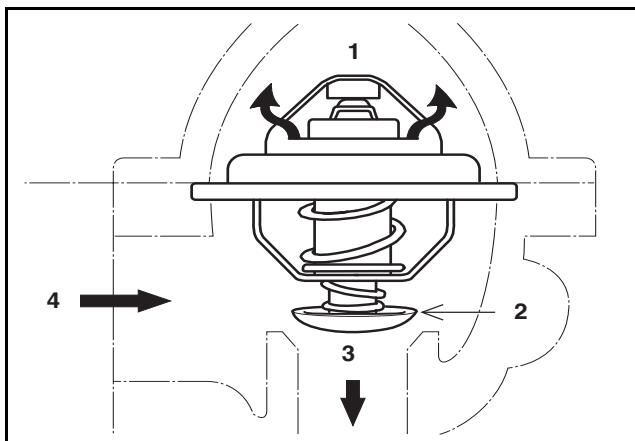

EDL022060A

- |                   |                 |
|-------------------|-----------------|
| 1. Heat exchanger | 3. Coolant pump |
| 2. Bypass valve   | 4. Coolant pipe |

### Inspection

1. Check the wax pellet and spring for damage.
2. Submerge the thermostat in water and heat the water slowly to check whether the thermostat operates properly.

If the lift is 0.1 mm (0.039 in.) (start of opening) at a water temperature of 71°C (160°F) and 8 mm (0.315 in.) (fully open) or more at a water temperature 85°C (185°F), the thermostat is normal.

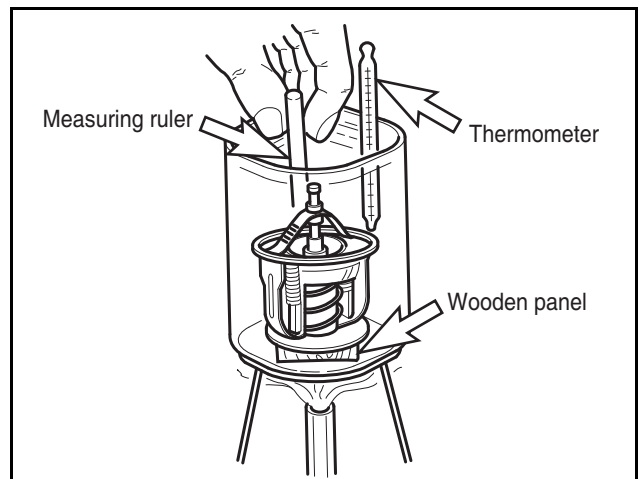

EFM2055I

### Cautions for Replacing and Handling the Thermostat

1. Cautions for handling
 

The reaction rate of the wax pellet type against changes in the coolant temperature is slower than that of the bellows type.

This is because the wax pellet type has a higher thermal capacity. Therefore, the engine must first be idled sufficiently to prevent a rapid rise in the engine coolant temperature. In cold weather, avoid overloading or overspeeding immediately after starting the engine.

When draining coolant from or adding coolant to the engine cooling system, drain or pour it slowly to allow enough air to escape from the system.
2. Replace the thermostat
 

If the thermostat is defective, replace it with a new one.

## 6. Cooling System

### Causes of Faults and Troubleshooting

Symptom	Possible Cause	Troubleshooting
Overheated engine	Insufficient coolant	Add coolant
	Loose radiator cap spring	Replace the cap
	Loose or broken fan belt	Adjust or replace the fan belt
	Fan belt contaminated with oil	Replace the fan belt
	Malfunctioning thermostat	Replace the thermostat
	Faulty coolant pump	Repair or replace
	Resistance due to contamination of coolant passage	Clean the radiator and coolant passage
	Incorrect injection timing	Adjust the injection timing
	Contaminated or clogged radiator air passage	Clean the outside of the radiator
	Coolant leakage due to damaged cylinder head gasket	Replace the cylinder head gasket
Overcooled engine	Malfunctioning thermostat	Replace the thermostat
	Excessively low ambient temperature	Cover the radiator
Insufficient coolant	Coolant leaking from radiator	Repair or replace
	Loose or damaged radiator coolant connection	Retighten the hose clamp or replace the hose
	Loose radiator cap valve spring	Replace the cap
	Leaky coolant pump	Repair or replace
	Loose or damaged heater hose connection	Tighten or replace the hose
	Leaky cylinder head gasket	Replace the cylinder head gasket
	Cracked cylinder head or block	Replace the cylinder head or block
Abnormal noise in cooling system	Faulty coolant pump bearing	Replace the bearing
	Loose or bent cooling fan	Retighten or replace the fan
	Uneven rotation of cooling fan	Replace the fan
	Faulty fan belt	Replace the fan belt

## Air Heater (Optional)

### Operating Conditions

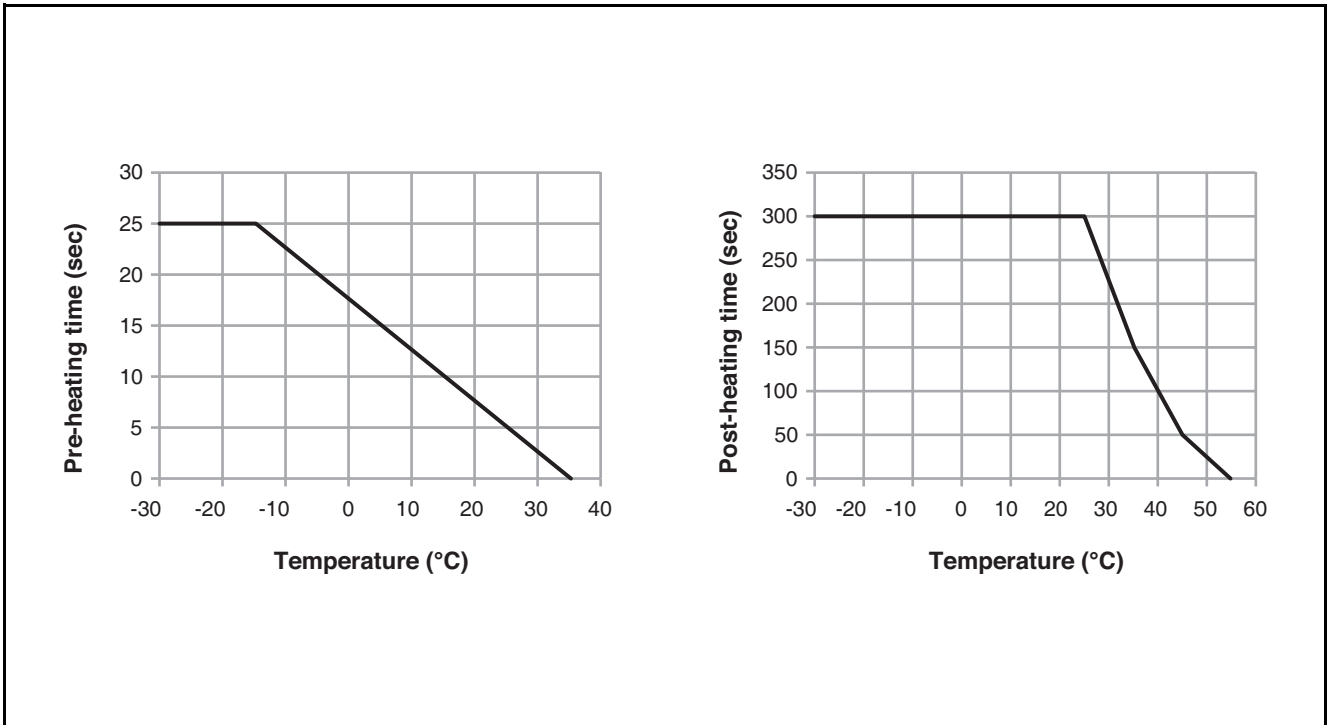

EDX22190243

### Circuit Diagram

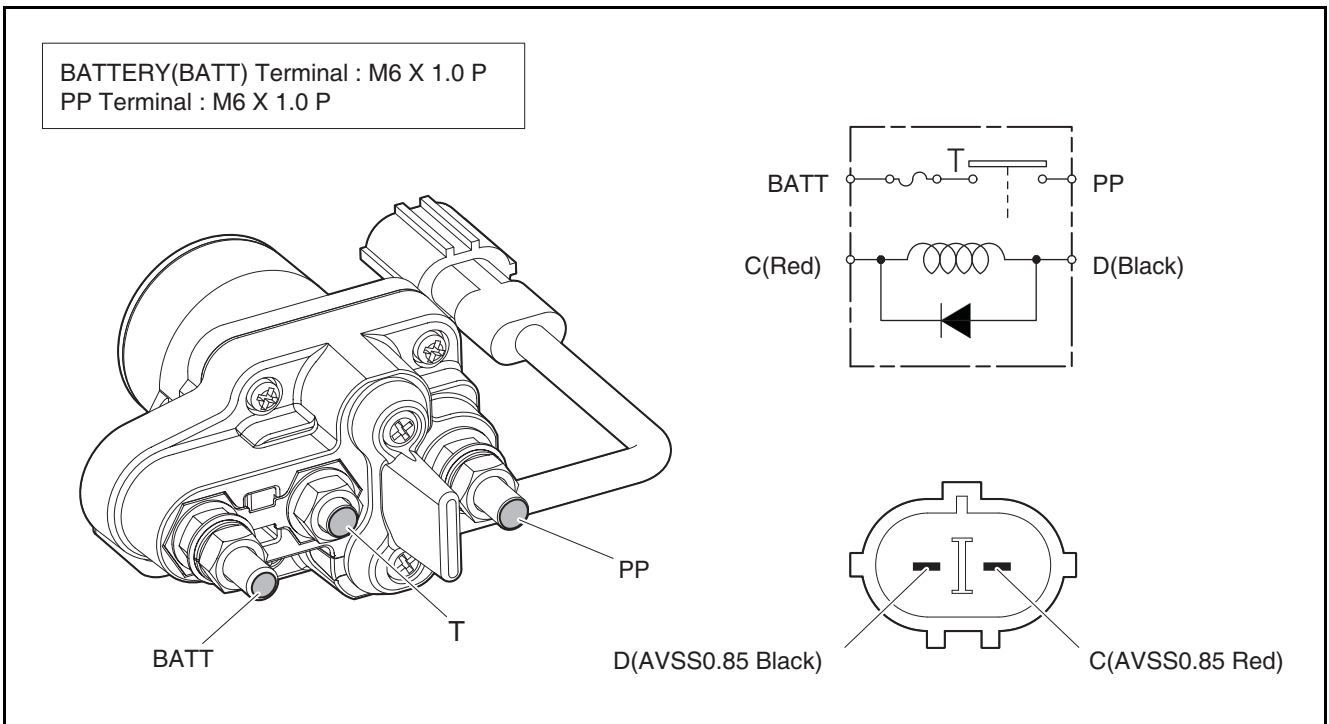

EDX22190241

## 6. Cooling System

---

# 7. Lubrication System

Overview and Specifications .....	95
General Information .....	95
Specifications .....	95
Lubrication Circuit Diagram.....	95
Oil Filter.....	96
Causes of Faults and Troubleshooting .....	96



## Overview and Specifications

### General Information

As engine oil is sucked and delivered from the oil pan by means of the gear-driven oil pump, all of it passes through the oil cooler and oil filter to be filtered; then, this filtered oil flows through the main oil gallery in the cylinder block to lubricate each engine bearing and the turbocharger in order to maintain normal engine performance.

### Specifications

Item	Specifications	Item	Specifications
Lubrication method	Forced circulation	Oil filter type	Full flow
Oil pump type	Gear driven	Cartridge bypass	
Relief valve opening pressure	8.5 ~ 10 bar (123.28 ~ 145.04 psi)	Valve opening pressure	2.5 ±0.3 bar (36.26 ±4.35 psi)
Oil injection nozzle adjustment		Oil cooler bypass	
Valve opening pressure	0.6 ~ 1.0 bar (8.70 ~ 14.50 psi)	Valve opening pressure	5.0 ±0.5 bar (72.52 ±7.25 psi)

### Lubrication Circuit Diagram

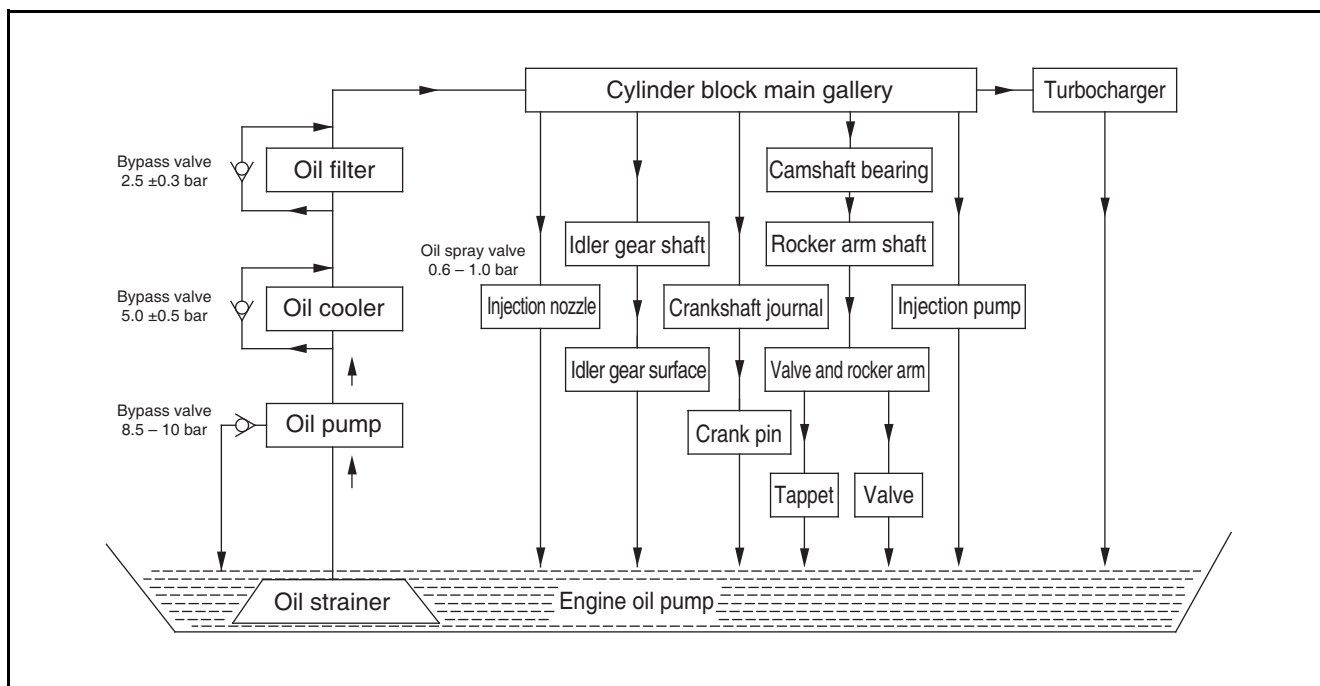

EDX22190036

## 7. Lubrication System

### Oil Filter

The oil filter installed in the engine is a cartridge-type filter. Make sure to replace it with a new one at the designated interval.

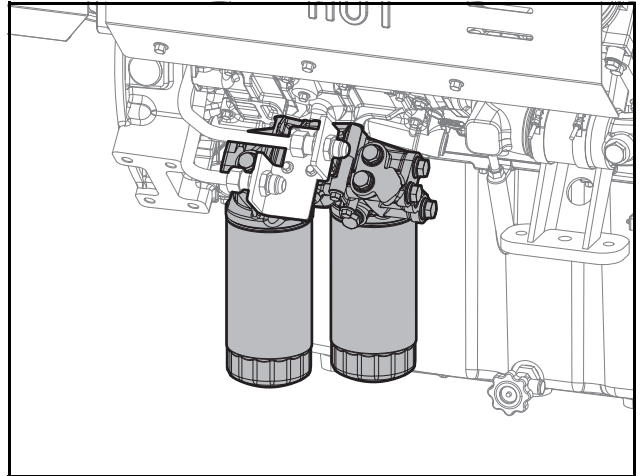

EDX15240025

### Causes of Faults and Troubleshooting

Symptom	Possible Cause	Troubleshooting
Excessive oil consumption	Poor oil quality	Use the specified oil
	Leaky oil seal ring and packing	Replace
	Worn piston and ring	Replace the piston and piston ring
	Worn cylinder liner	Replace the cylinder liner
	Seized piston ring	Replace the piston and piston ring
	Worn valve guide oil seal, valve guide, or valve stem	Replace
Oil pressure drop	Poor oil quality	Use the specified oil
	Seized oil pump relief valve	Replace
	Clogged oil pump strainer	Wash the strainer
	Worn oil pump gear	Replace
	Cracked oil pump delivery pipe	Replace
	Defective oil pump	Repair or replace
	Defective hydraulic system	Repair or replace
	Worn bearing	Replace
Contaminated oil	Clogged oil filter	Replace the oil filter cartridge
	Gas leak	Replace the piston ring and cylinder liner

# 8. Fuel System

- General Information .....99
  - General Information ..... 99
- Fuel System Components .....100
  - Caution..... 100
  - Fuel Tank ..... 100
  - Fuel Lines Connected to the Engine..... 101
  - Three-Way Valve ..... 102
  - Hand Priming Pump and Connecting Adapter ..... 102
  - Primary Fuel Filter, Connecting Adapter, Fuel Heater, Service Tool ..... 104
  - Engine Fuel Inlet/Outlet Ports ..... 113
  - Low-Pressure Fuel Pump ..... 115
  - Secondary Fuel Filter..... 116
  - High-Pressure Fuel Pump..... 117
  - Common Rail ..... 118
  - High-Pressure Fuel Pipe ..... 118
  - Injectors, High-Pressure Fuel Connectors ..... 119



## General Information

### General Information

This engine is equipped with a high-pressure common rail fuel injection system and consists of the components shown in the "fuel system schematic diagram" below. The system is designed to function optimally according to the engine performance. After leaving the fuel tank and passing through the primary fuel filter (oil-water separator), fuel is filtered of all water and large particles of foreign matter; then, the fuel is sent to the secondary fuel filter by the low-pressure gear pump installed in the high-pressure fuel pump. Here, small particles of foreign matter which may cause problems in the injection system are removed. Then, after the fuel is pressurized to a suitably high pressure for the required engine performance, the fuel is sent to the common rail where it is injected into the combustion chamber at a high pressure by injectors controlled by the ECU. The fuel remaining after combustion is complete and the fuel used to lubricate and cool the high-pressure pump, common rail and injectors are gathered together and returned to the fuel tank.

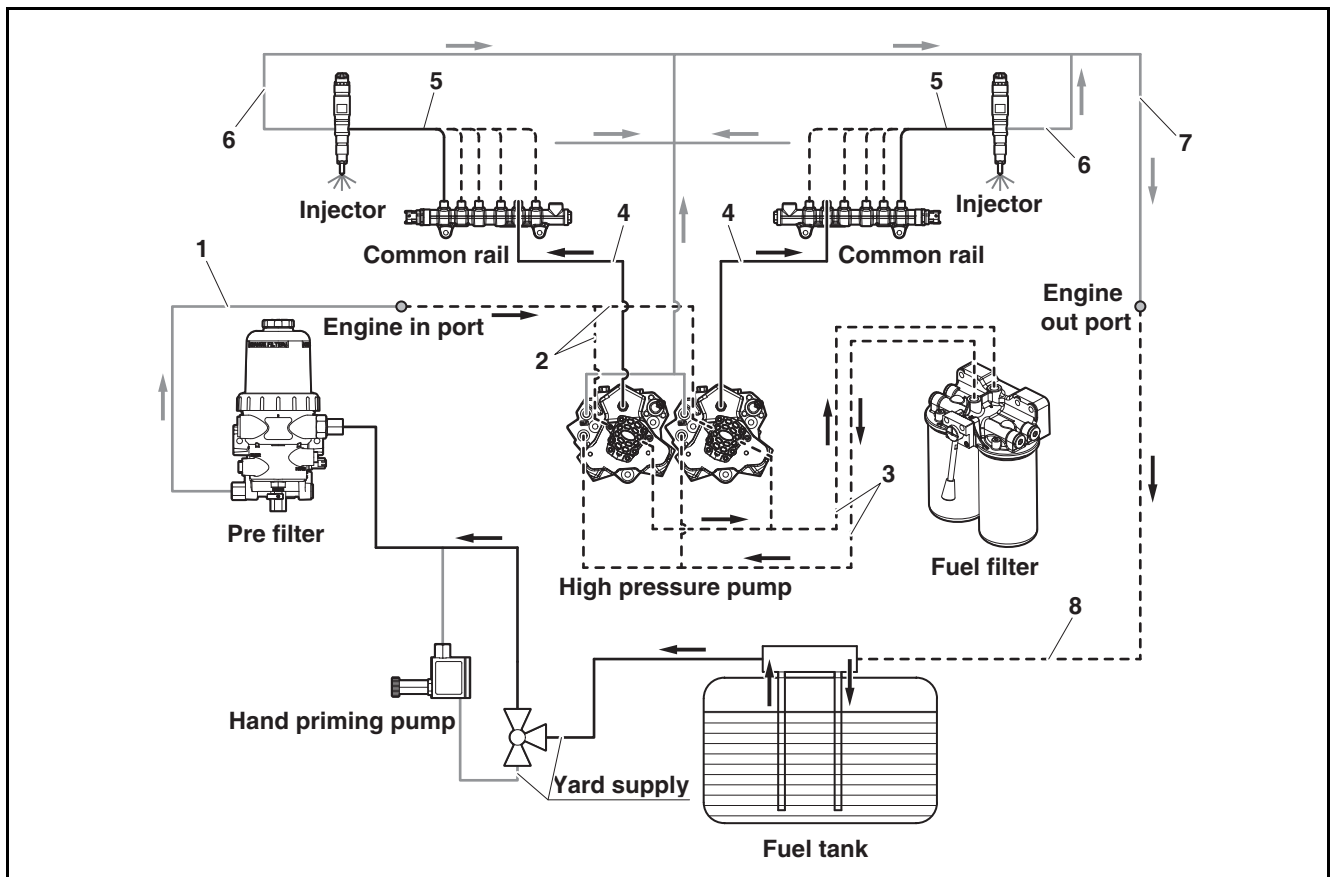

EDX15240201

No.	Part (Position)	Material	Inner DIA.	Allowable Pressure
1	Fuel hose (engine inlet)	Synthetic rubber	Ø19	10 bar
2	Fuel line (GP inlet)	St37.4 NBK	Ø12.6	170 bar
3	Fuel line (filter in/out)	St37.4 NBK	Ø12.6	170 bar
4	Injection pipe (pump to rail)	USIT-SP 850J	Ø4	3,000 bar
5	Injection pipe (rail to injector)	USIT-SP 850J	Ø4	3,000 bar
6	Fuel line (injector return)	STKM 11A	Ø4	196 bar
7	Fuel line (fuel return)	St37.4 NBK	Ø12.6	170 bar
8	Fuel hose (fuel return)	Synthetic rubber	Ø19	10 bar

## 8. Fuel System

---

### Fuel System Components

#### Caution

- The common rail fuel injection system operates at high pressures (1,800 bar). Accordingly, the system must be handled and serviced with care, and the safety regulations must always be followed.
- The common rail fuel injection system should never be removed, installed or inspected while the engine is running or immediately after stopping the engine; inspections and service work should be performed at least 30 seconds to one minute after stopping the engine.
- During service work and inspections, make sure that the workspace is clean before performing any work to prevent foreign matter from entering the fuel system; keep any unnecessary removal and installation to a minimum; and in the case of parts which must be reused during removal and installation, take the necessary measures to prevent foreign matter from entering the parts after removing them and clean them before reusing them for installation.
- The normal performance of O-rings and sealing washers used on high-pressure fuel pipes and in the fuel system cannot be guaranteed if they are reused; make sure to use new parts.
- When assembling high-pressure fuel pumps, common rails, injectors, and high-pressure fuel pipes, take care to prevent damage due to impacts, etc. resulting from carelessness and make sure to assemble them precisely.

### Fuel Tank

The fuel tank must be able to store fuel cleanly and safely and must be structured to satisfy the following requirements so as not to affect the components of the engine injection system.

#### Material

Zinc (Zn), copper (Cu), lead (Pb), sodium (Na) and calcium (Ca) cause chemical reactions with water in fuel and biodiesel, thereby forming various corrosive acids, sludge and viscous substances. When this occurs, it causes premature clogging of the primary fuel filter, seizure of injectors, corrosion and wear of fuel system components, including the injection system, leading to excessive maintenance expenses resulting from engine failure. Hence, when the use of these materials cannot be avoided, make sure to apply a phosphate film or trivalent chromium plating to prevent the materials from coming into direct contact with fuel.

#### Air Intake/Discharge System

When fuel is delivered to the engine, a reduction in pressure equivalent to the volume occupied by the fuel in the tank occurs, leading to a fluctuation in the volume of fuel as a result of a change in the fuel temperature. Hence, if the fuel tank is an enclosed structure, excessive static/negative pressure is formed, causing abnormal engine operation. Accordingly, the fuel tank must be equipped with an air intake/discharge system to constantly maintain atmospheric pressure, while the ports through which air is drawn in or discharged must be connected by means of extension hoses or tubes to a clean environment with minimal dust, moisture, insects, etc. or a suitable air filter must be installed to prevent such foreign matter from entering the system. When air inlets and outlets are installed in extremely dusty or humid areas, the service life of the primary and secondary fuel filters is severely reduced, while wear and corrosion of injection system components are accelerated, resulting in a shortened service life and excessive maintenance expenses.

#### Port for Draining Condensate and Cleaning Foreign Matter

Inside the fuel tank, foreign matter entering through the air inlet and outlet ports as well as condensate on the inner wall of the tank resulting from the difference in temperature between fuel and ambient air form deposits continuously. The fuel tank must be equipped with a cleaning port for periodically removing and cleaning condensate and foreign matter to prevent foreign matter and condensate deposits in the tank from entering the engine fuel system.

## Fuel Lines Connected to the Engine

### Material

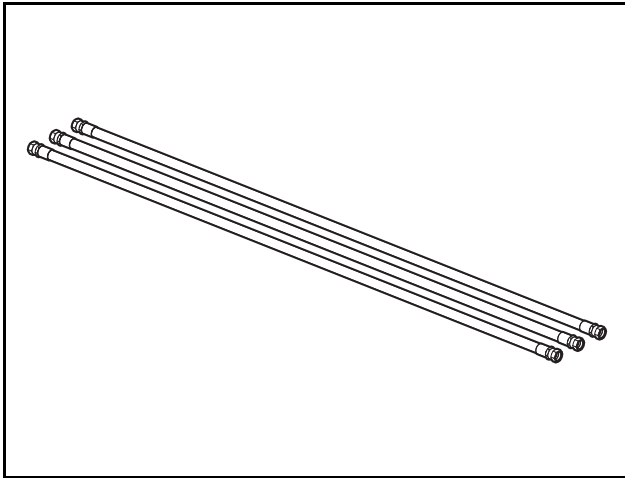

EDX22190172

Since the fuel lines connecting the engine and the fuel tank must be flexible enough to withstand vibrations while the engine is running, it is recommended to use hoses.

The DP222C engine includes three two-meter fuel hoses (420103-00602) packaged separately and provided along with the engine. Make sure to install and use them where necessary on the primary fuel filter, hand priming pump, and fuel tank.

When additional fuel hoses of different lengths are required, use the fuel hose specifications provided to order hoses of the desired length from a hose supplier.

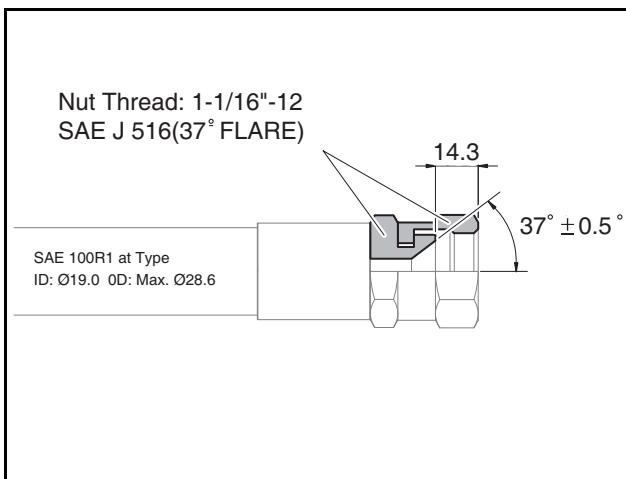

EDX22190173

< Fuel hose specifications >

Hose	SAE 100R1 AT Type I.D. Ø19.0, O.D. max. Ø28.6
Hose coupling	SAE J516 37° Flare, 1 1/16" - 12 UNF

## Piping Layout

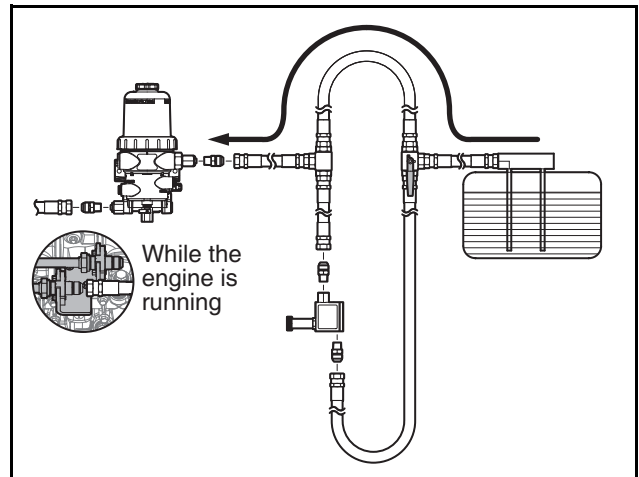

EDX22190174

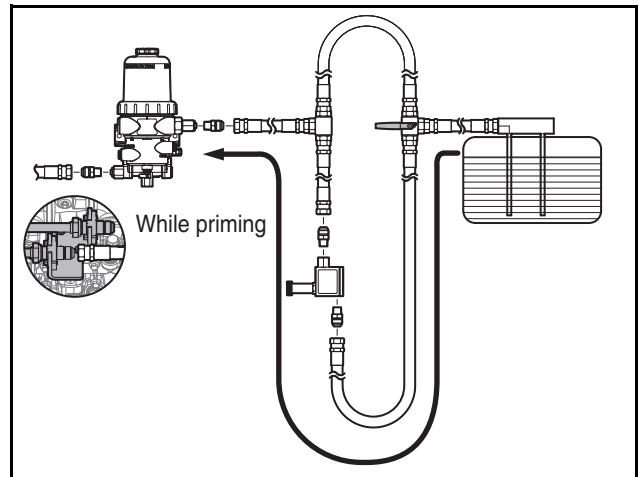

EDX22190175

The fuel lines connecting the fuel tank and primary fuel filter and the piping connected to the hand priming pump must be configured as shown in the figure on the right. When the engine is running with a three-way valve installed, make sure to configure the piping so as to prevent fuel from passing unnecessarily through the hand priming pump and causing a loss of suction pressure.

# 8. Fuel System

## Three-Way Valve

### Materials and Specifications

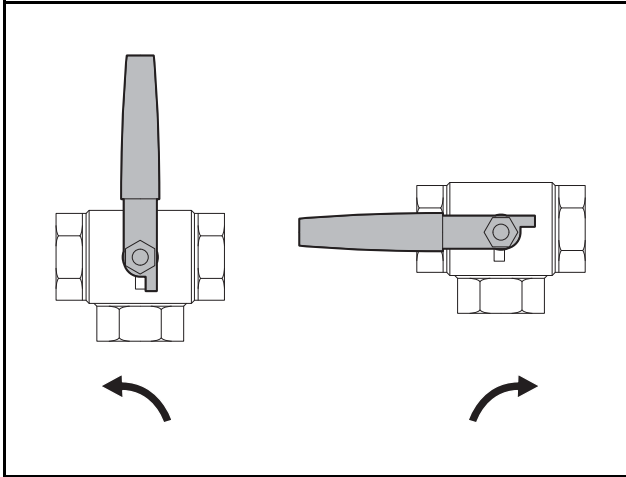

EDX22190176

Zinc (Zn), copper (Cu), lead (Pb), sodium (Na) and calcium (Ca) cause chemical reactions with water in fuel and biodiesel, thereby forming various corrosive acids, sludge and viscous substances.

When this occurs, it causes premature clogging of the primary fuel filter, seizure of injectors, corrosion and wear of fuel system components, including the injection system, leading to excessive maintenance expenses resulting from engine failure. Hence, in addition to using stainless materials, please refer to the figure on the right to purchase and install threaded products among the commercially available L-type three-way valves to enable piping to be connected easily.

### Hand Priming Pump and Connecting Adapter Components

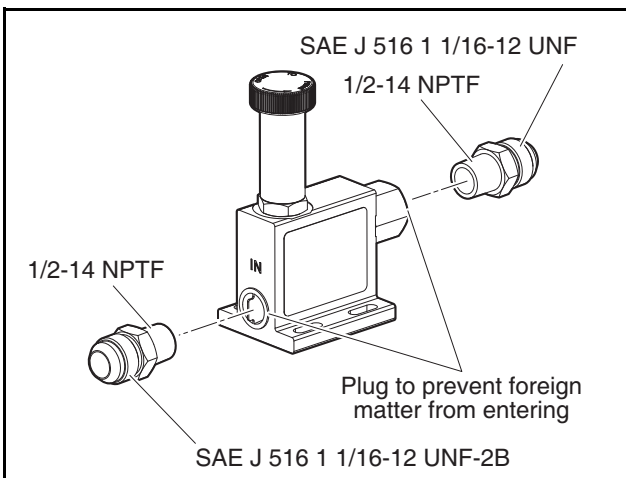

EDX22190177

A hand priming pump and two piping connecting adapters are provided as separate accessories along with the engine.

## Installation

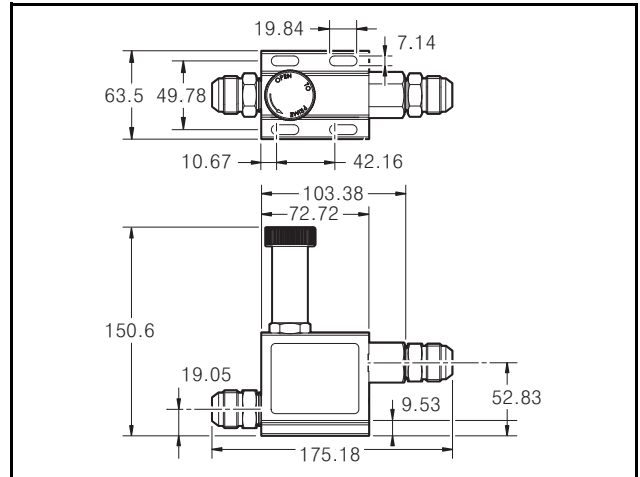

EDX22190178

1. Remove the plug for preventing foreign matter from entering the hand priming pump and tighten the connecting adapters provided to the specified torque.

Torque	5 ±0.5 kgf·m (36.1651 ±3.6165 lbf·ft)
--------	---------------------------------------

As illustrated by the installation location in the fuel system schematic diagram, the hand priming pump must be located between the three-way valve and primary fuel filter, and four M6 bolts should be installed firmly in locations which do not disrupt the generator set controls in order to prevent looseness and unnecessary movement during operation.

When tightening piping couplings, tighten the coupling with the connecting adapter on the hand priming pump secured with a 27 mm spanner to prevent the adapter from turning along with the coupling.

Make sure that the tightening torque of piping being connected does not exceed a maximum of 9.5 kgf·m (68.71 lbf·ft).

## Operation

The hand priming pump is used for priming to remove air remaining in the fuel passages after service work which requires the removal and installation of engine fuel system components and the primary/secondary fuel filters.

1. Turn the handle on the hand priming pump counterclockwise by hand to unlock the pump.

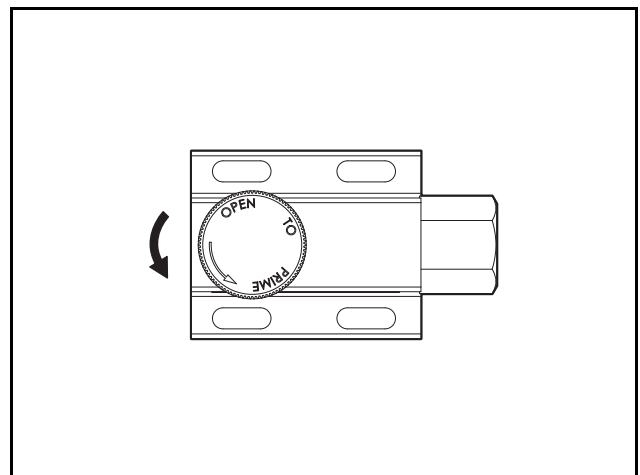

EDX22190179

2. Pump the handle up and down by hand to prime the pump.

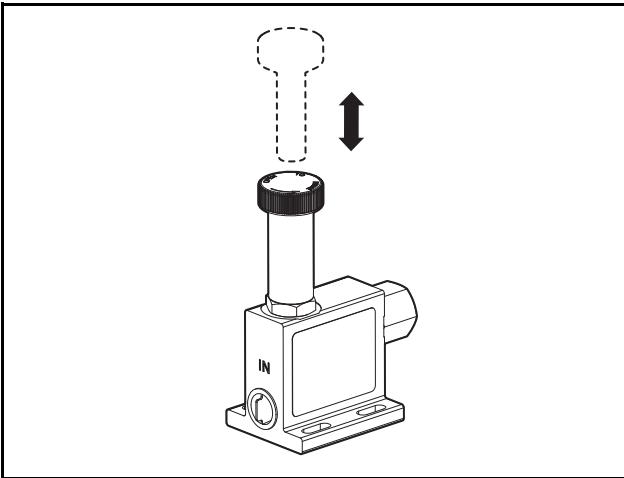

EDX22190202

3. After priming is complete, press the handle into the compressed position by hand; then, wind it in the clockwise direction to lock it.

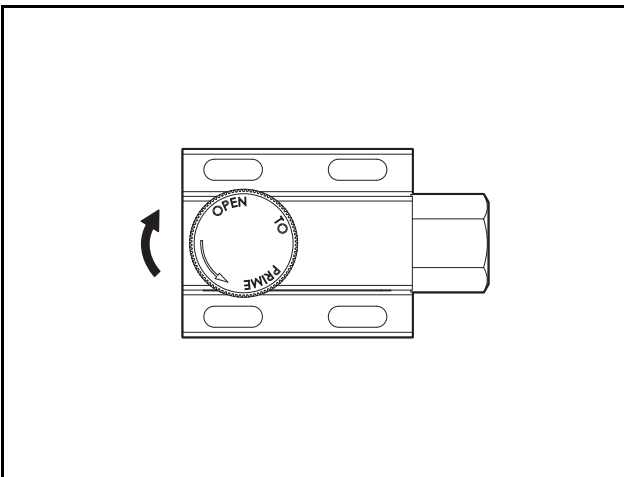

EDX22190203

## 8. Fuel System

### Primary Fuel Filter, Connecting Adapter, Fuel Heater, Service Tool

#### Components

A primary fuel filter, two piping connecting adapters, fuel heaters, and a service tool are provided as separate accessories along with the engine.

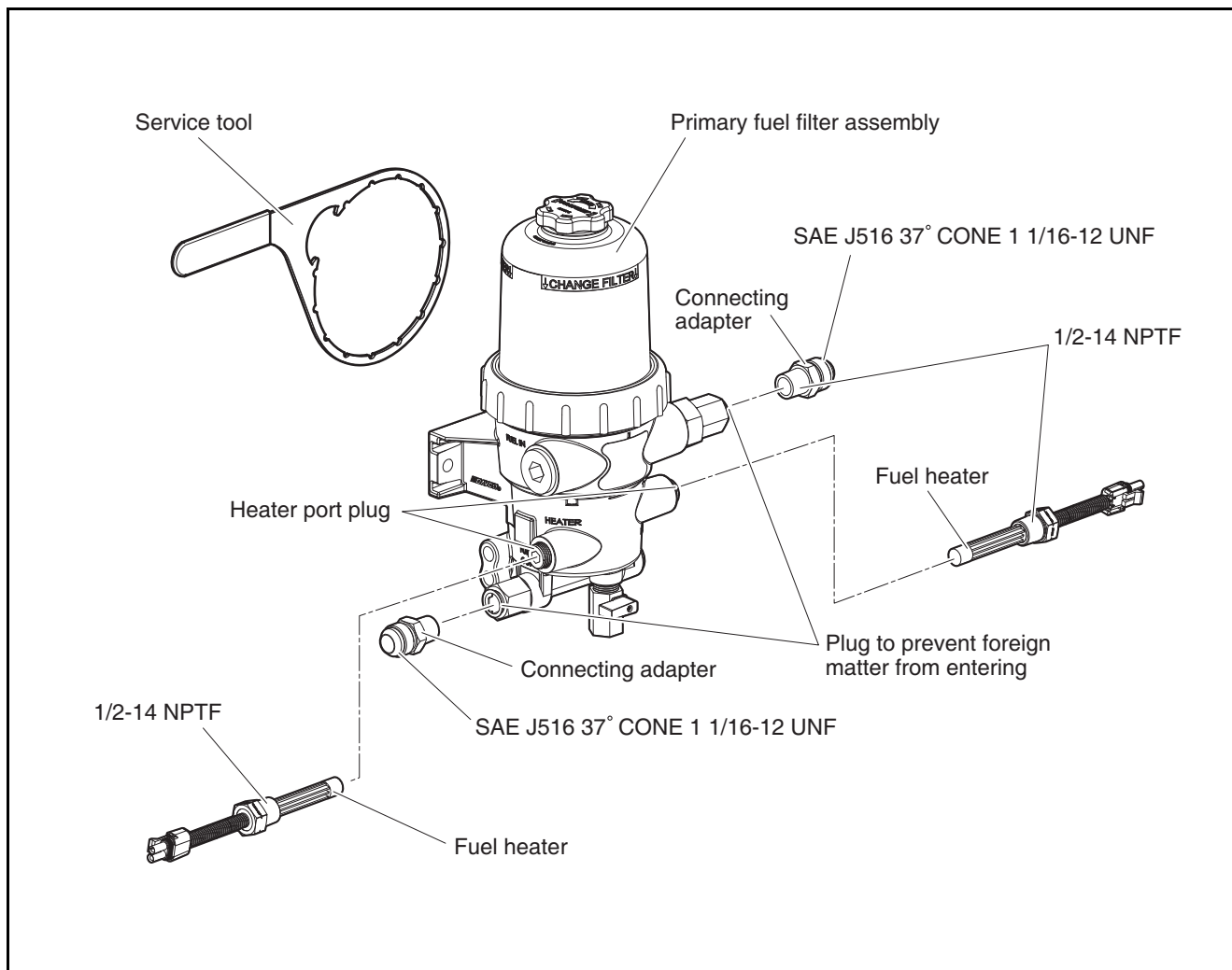

EDX22190180

## Installation

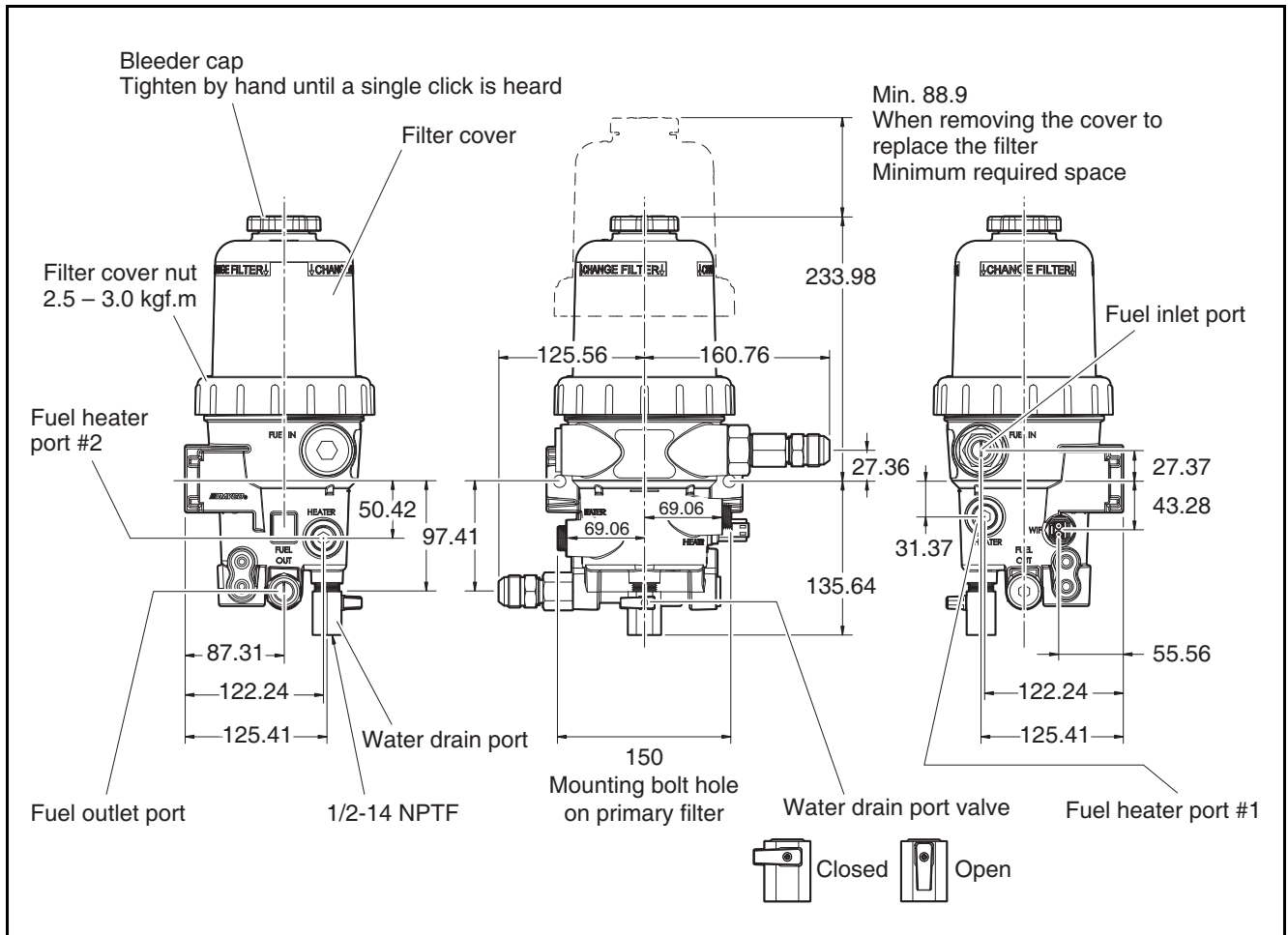

EDX22190181

## 8. Fuel System

1. Mounting the primary fuel filter and connecting the fuel lines

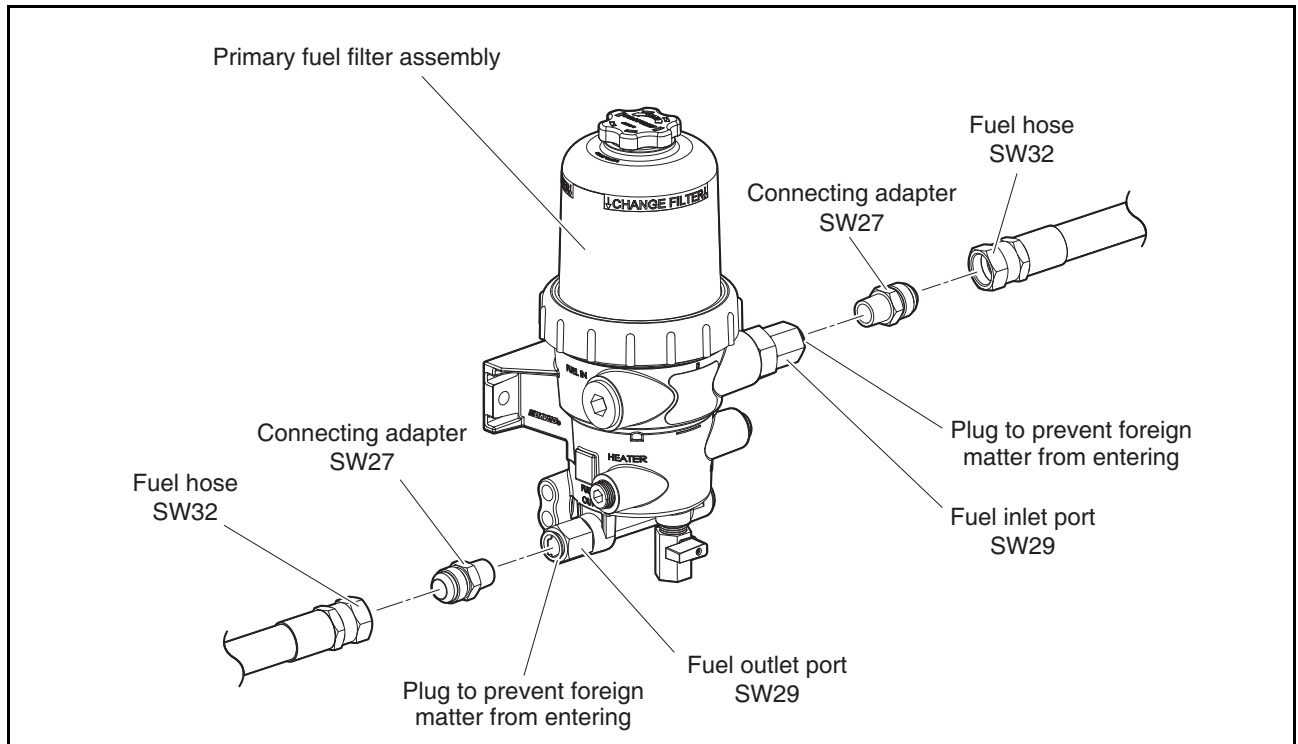

EDX22190183

Remove the plugs for preventing foreign matter from entering the fuel inlet/outlet of the primary fuel filter and tighten the connecting adapters provided to the specified torque. (Specified tightening torque for adapters:  $5 \pm 0.5$  kgf·m /  $36.17 \pm 3.62$  lbf·ft) When tightening the adapters, tighten them with the fuel inlet/outlet ports on the primary fuel filter secured with a 29 mm (1.14 in.) spanner to prevent the ports from turning along with the adapters.

As illustrated by the installation location in the fuel system schematic diagram, the primary fuel filter must be located between the fuel tank and the engine, and two M10 bolts should be installed firmly in locations which do not disrupt the periodic water draining and filter replacement of the generator set in order to prevent looseness and unnecessary movement during operation.

When tightening piping couplings, tighten the coupling with the connecting adapter on the primary fuel filter secured with a 27 mm (1.06 in.) spanner to prevent the adapter from turning along with the coupling, and make sure that the tightening torque of piping being connected does not exceed a maximum of 9.5 kgf·m (68.71 lbf·ft).

### 2. Connecting the fuel heater

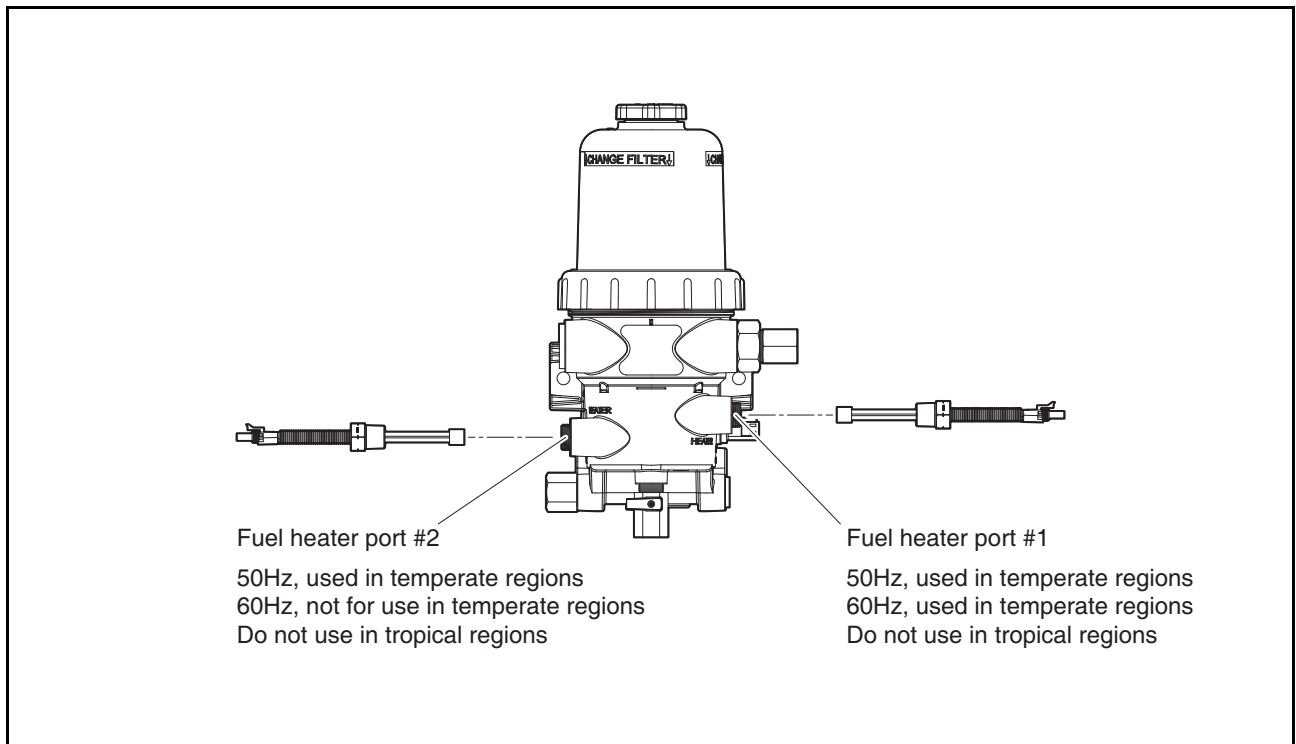

EDX22190184

The number of fuel heaters is defined by the frequency produced by the generator set and the lowest annual temperature of the area in which the generator is installed.

Make sure to check the information on the wiring circuit and power consumption before installing the heater to ensure normal operation.

(Temperate areas: Areas where the lowest annual temperature is  $-15^{\circ}\text{C}$  ( $5^{\circ}\text{F}$ ) or higher, tropical areas: Areas where the lowest annual temperature is  $2^{\circ}\text{C}$  ( $35.6^{\circ}\text{F}$ ) or higher)

- Number of fuel heaters  
Two heaters in temperate areas of 50 Hz, one heater in temperate areas of 60 Hz, none in tropical areas
- Fuel heater tightening torque: 2 ~ 4 kgf·m (14.5 ~ 28.9 lbf·ft)
- Fuel heater specifications (for one heater)  
Operating voltage: 24 VDC  
Normal operating current: 4.5 A @ 24 V  
Maximum operating current: 14 A @ 24 V  
Operating power: 195 W  
Operating temperature:  $2 \pm 5^{\circ}\text{C}$  ( $35.6 \pm 41^{\circ}\text{F}$ ) On,  $24 \pm 5^{\circ}\text{C}$  ( $75.2 \pm 41^{\circ}\text{F}$ ) Off  
Resistance:  $2.0 \Omega \sim 3.0 \Omega$  @  $25^{\circ}\text{C}$  ( $77^{\circ}\text{F}$ )

## 8. Fuel System

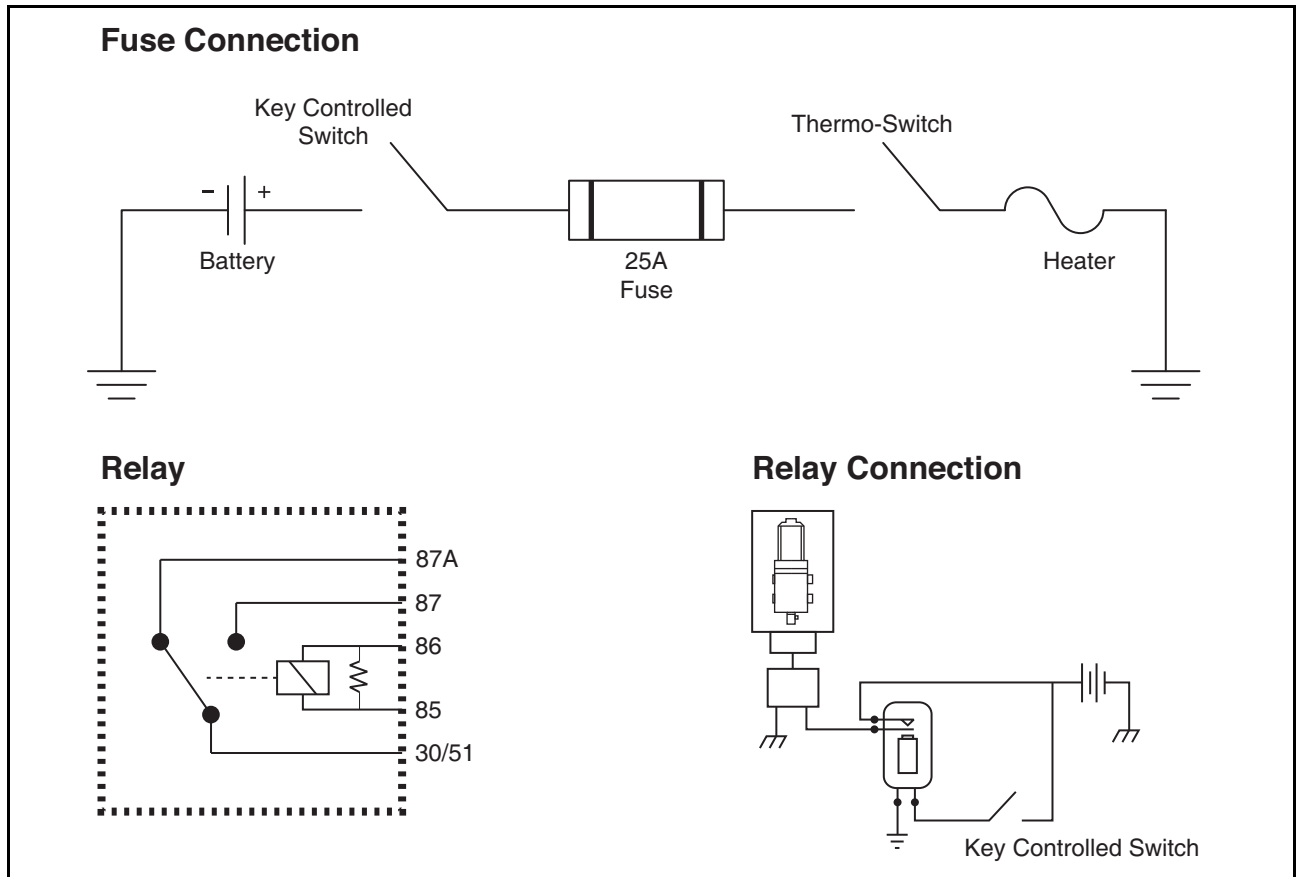

EDX22190144

- Fuel heater wiring circuit layout (for one heater)  
Refer to circuit diagram
- Wiring connector information  
Polarity: Non-polar  
Wiring specifications: 14 AWG GXL Wire  
Connectors and terminals: See table on the right  
Since the ECU does not control the fuel heater, even if the generator set control panel turns on the power, the heater only operates when the fuel temperature meets the specific requirements.  
Accordingly, either install the heater so that it is connected to the main power source of the generator control panel to ensure that the heater receives constant power and turns on automatically, or install an on/off switch for the heater to enable the power to be turned on only when necessary and to ensure that the heater can be activated manually and selectively.

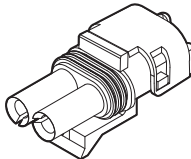
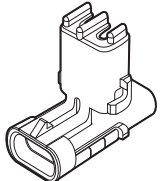
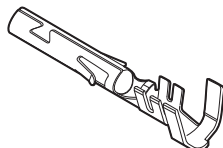
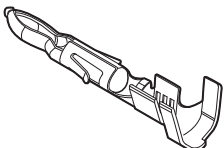
Item	Heater	Generator set
Connector	<p>APTIV 12103584</p>  <p>Two-way brown weather pack tower sealed male connector</p>	<p>APTIV 12010973</p>  <p>Two-way black weather pack shroud sealed male connector</p>
Terminal	<p>APTIV 12124580</p>  <p>Weather pack female sealed tin plating tank terminal. Cable range 1.00 ~ 2.00 mm<sup>2</sup> (0.039 ~ 0.079 in<sup>2</sup>)</p>	<p>APTIV 12124582</p>  <p>Weather pack male sealed tin plating tank terminal. Cable range 1.00 ~ 2.00 mm<sup>2</sup> (0.039 ~ 0.079 in<sup>2</sup>)</p>

## 3. Connecting the water in fuel sensor switch

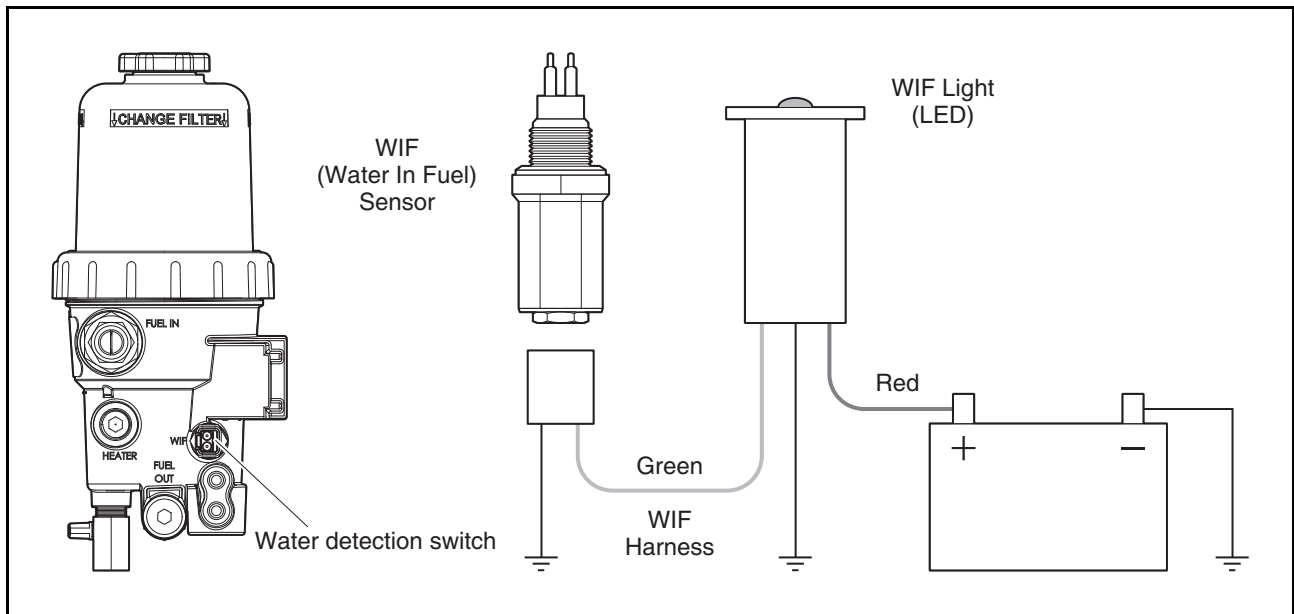

EDX22190189

The water in fuel sensor switch is used to notify the operator that drainage is necessary when the water collected in the primary fuel filter exceeds a certain volume. Water particles filtered out by the primary fuel filter cartridge sink to the bottom of the primary fuel filter due to the difference in weight between fuel and water particles. When a certain amount of particles accumulates and the water level reaches the probe of the water in fuel sensor switch, an electrical connection with the probe is created by the water and power is supplied to the LED lamp or buzzer installed on the generator set control panel to activate an alarm.

- Water storage capacity of the primary fuel filter  
Start of electrical connection with water in fuel sensor switch: 210 ml (0.06 gal.)  
Maximum water capacity: 500 ml (0.13 gal.)
- Tightening torque of water in fuel sensor switch: 0.5 ~ 0.6 kgf·m (3.6165 ~ 4.3398 lbf·ft)  
(Provided pre-assembled in the generator upon release from the factory.)
- Water in fuel sensor switch specifications  
Operating voltage: 5 ~ 50 VDC or VAC  
Resistance: 82 kΩ ±2% @ 25°C (77°F)
- Water in fuel sensor switch wiring circuit
- Wiring connector information  
Polarity: Non-polar  
Connectors and terminals: See table on the right

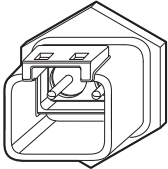
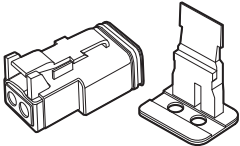
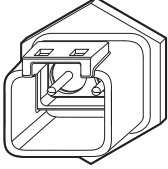
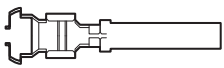
Item	Water in fuel sensor switch	Generator set
Connector	DEUTSCH DT04-2PA 	DEUTSCH DT06-2S 
Terminal	Size 16 for DT04-2P  Pin	Size 16 for DT06-2S  Socket

# 8. Fuel System

## Operation

1. Fuel heater operation at low temperatures
  - 1) To ensure smooth start-up in winter and at low temperatures, run and preheat the primary fuel filter heater five minutes before starting the engine to remove the paraffin in the fuel accumulated in the fuel filter.  
The fuel heater turns on at a fuel temperature of  $-2^{\circ}\text{C}$  ( $-28.4^{\circ}\text{F}$ ). Once the temperature rises to  $24^{\circ}\text{C}$  ( $75.2^{\circ}\text{F}$ ), the heater turns off automatically, and when the fuel temperature drops below  $-2^{\circ}\text{C}$  ( $-28.4^{\circ}\text{F}$ ) again, it turns on again.

### CAUTION

To ensure smooth engine start-up, maintenance, and normal engine power in winter, make sure to use winter fuel.

If summer fuel is used in winter, an excessive amount of paraffin forms in the fuel and the fuel flow in the fuel lines is restricted, thereby clogging the cartridges in the primary/secondary filters and causing delayed start-up or engine shutoff.

2. Replacing the cartridge of the primary fuel filter at replacement intervals

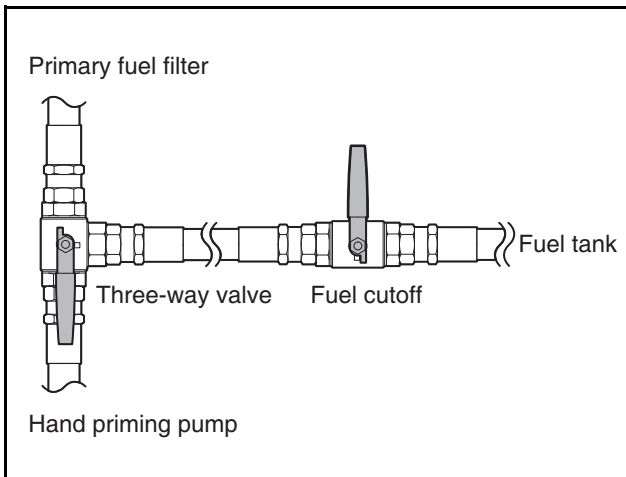

EDX22190193

- 1) Turn the manual valve on the fuel line supplying fuel from the fuel tank to the fuel shutoff position.

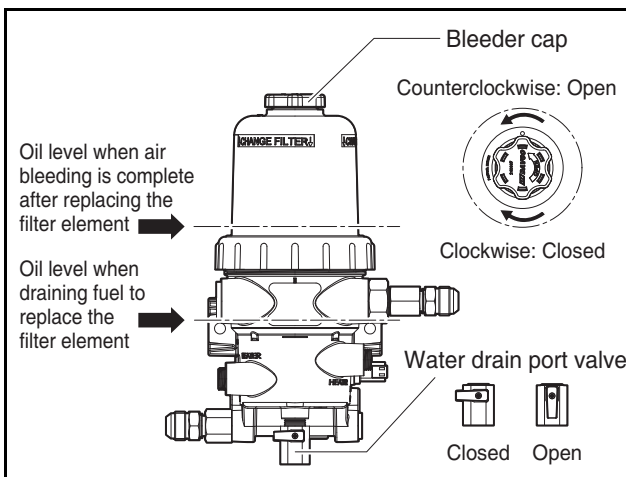

EDX22190194

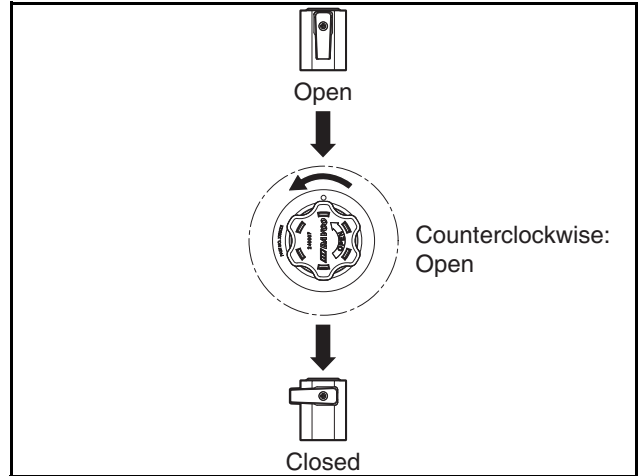

EDX22190205

- 2) To drain the fuel in the primary fuel filter, open the water drainage port valve on the bottom; then, open the air bleeder cap on top to enable fuel to be drained smoothly. During this step, not all of the fuel in the fuel filter must be drained. Once the fuel level decreases below the filter cover nuts, turn the valve to the locked position again to stop draining the fuel.

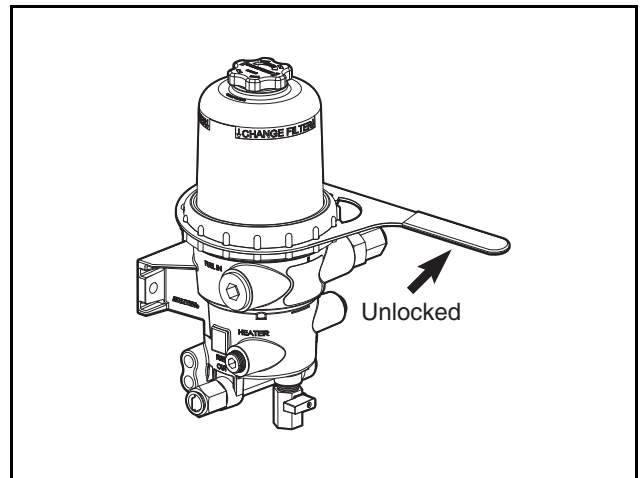

EDX22190195

- 3) Use a service tool to remove the filter cover and cover mounting nuts.

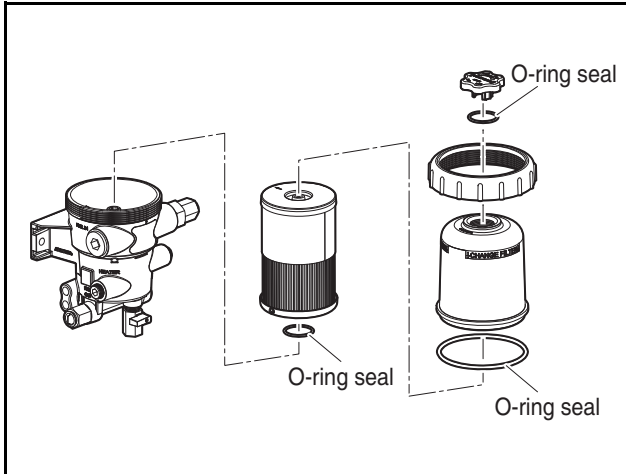

EDX22190196

- 4) Remove the old cartridge and replace it with a new one; then, temporarily assemble the cover, nuts and cap in the reverse order of disassembly.

### **⚠ CAUTION**

Before temporarily assembling the parts, make sure to check whether any O-ring seals are missing and whether there is any contamination due to foreign matter.

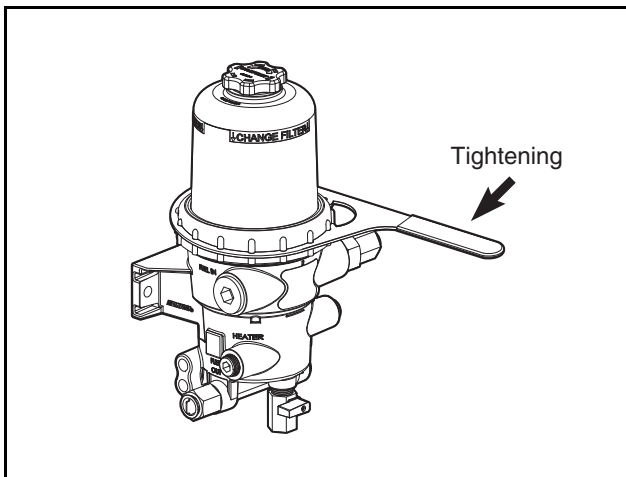

EDX22190197

- 5) Use a service tool to tighten only the filter cover mounting nuts to 2.5 ~ 3.0 kgf·m (18.0825 ~ 21.699 lbf·ft) while keeping the bleeder cap temporarily assembled.

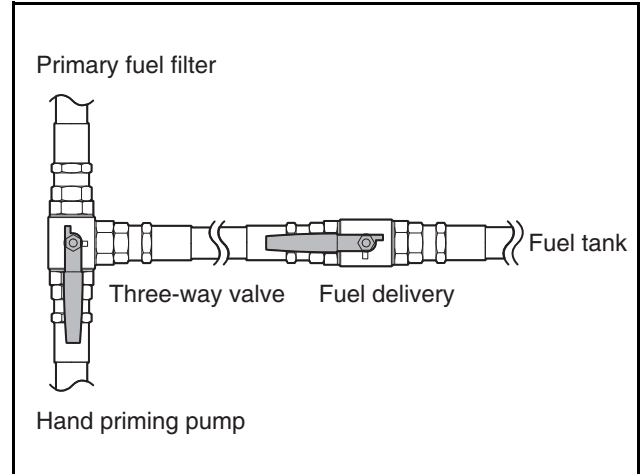

EDX22190198

- 6) Turn the manual valve on the fuel line supplying fuel from the fuel tank to the fuel delivery position.

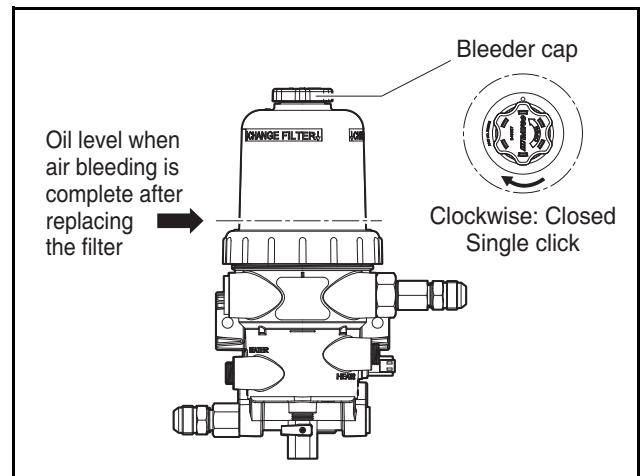

EDX22190199

- 7) Once the air bleeding procedure has been performed, the cartridge replacement is complete.
- If the fuel level in the fuel tank is higher than that of the primary fuel filter  
When the filter bleeder cap is open, fuel filling and air bleeding occur automatically in the filter due to the fuel differential head. When the fuel level reaches the replacement indicator position, tighten the bleeder cap by hand until a single click is heard to finish replacing the cartridge.

## 8. Fuel System

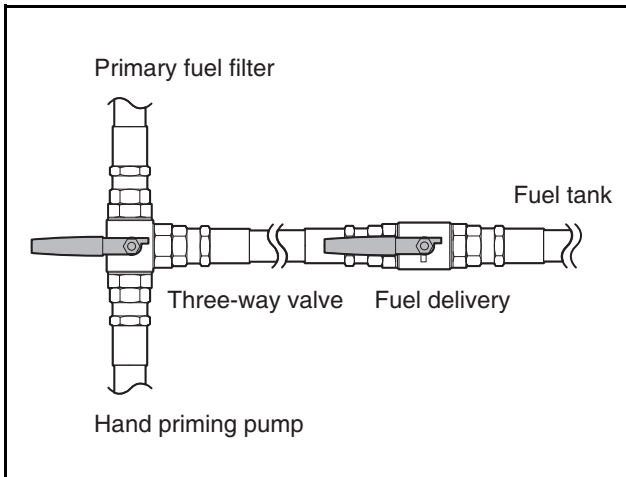

EDX22190200

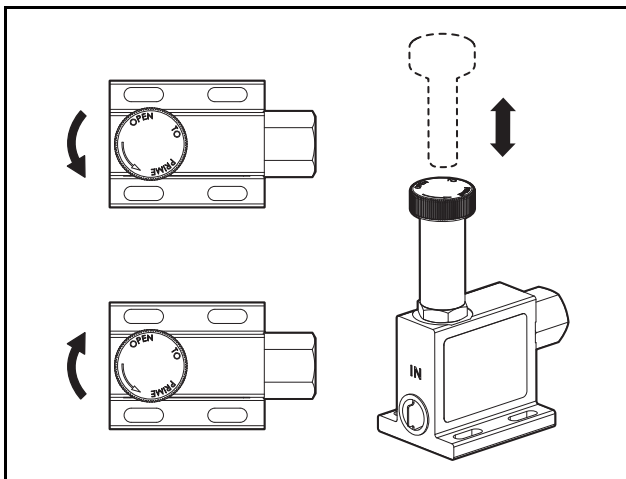

EDX22190204

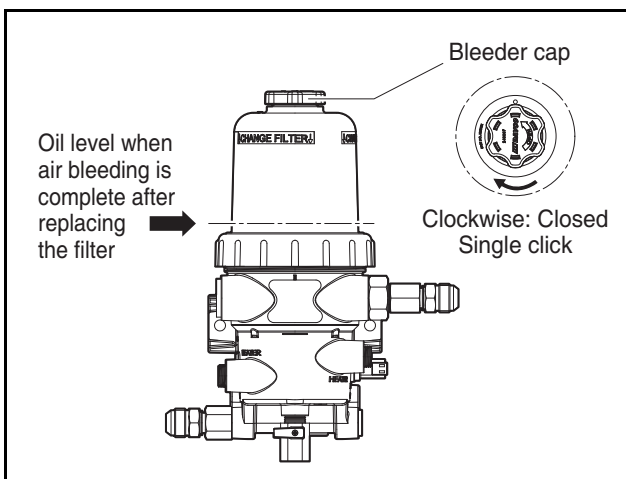

EDX22190199

- If the fuel level in the fuel tank is lower than that of the primary fuel filter  
After operating the three-way valve to pump fuel through the hand priming pump with the bleeder valve open, prime the pump to fill the primary fuel filter with fuel and bleed the air in the filter.

When the fuel level in the filter reaches the cartridge marking above the cover mounting nuts, tighten the bleeder cap by hand until a single click is heard; then, operate the three-way valve to cause fuel to flow into the primary filter and finish replacing the cartridge.

### **CAUTION**

**Fuel is a flammable and toxic substance, so make sure to check for and remove any sources of heat and sparks nearby and ventilate the workspace well before replacing the filter cartridge.**

**When draining the fuel in the filter to replace the cartridge, drain the fuel into a fuel storage container to prevent environmental contamination and dispose of drained fuel according to the proper disposal procedures.**

### 3. Draining water

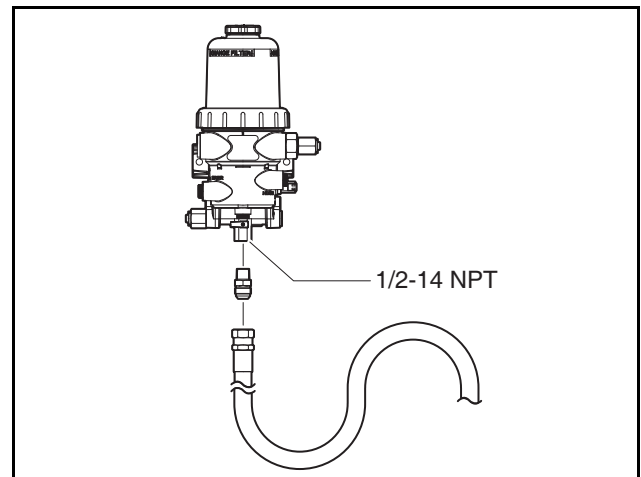

EDX22190201

- 1) Before starting the engine each day, open the water drain valve under the primary fuel filter to drain the water collected in the filter.
- 2) The water drain port is equipped with a 1/2-14 NPT female screw which allows an additional hose to be installed on the generator set to extend the drain port.

## Engine Fuel Inlet/Outlet Ports

The fuel inlet/outlet ports are located on top of the engine oil filter head on the right side of the engine. Either connect the fuel hoses provided to the fuel tank and primary fuel filter or order separate fuel hoses which satisfy the specifications below and connect them. Make sure that the tightening torque of pipes being connected to the fuel inlet/outlet ports does not exceed a maximum of 9.5 kgf·m (68.7136 lbf·ft).

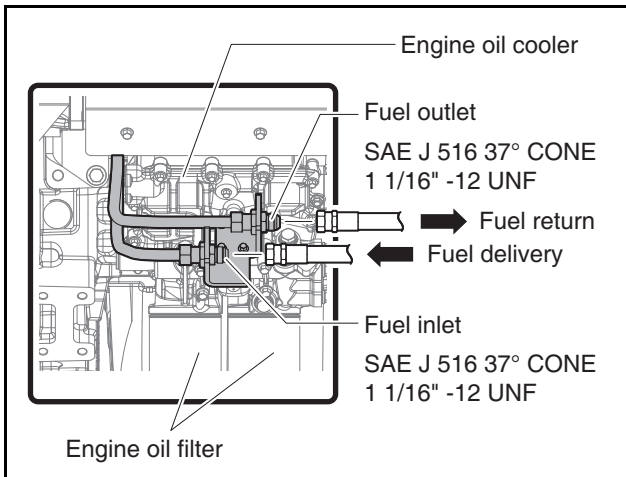

EDX15240106

### < Fuel hose specifications >

Hose	SAE 100R1 AT Type I.D. Ø19.0, O.D. max. Ø28.6
Hose coupling	SAE J516 37° Flare, 1 1/16" - 12 UNF

## Components

The engine fuel inlet/outlet ports consist of two pipe connecting adapters and a bracket for securing the adapters.

## Installation

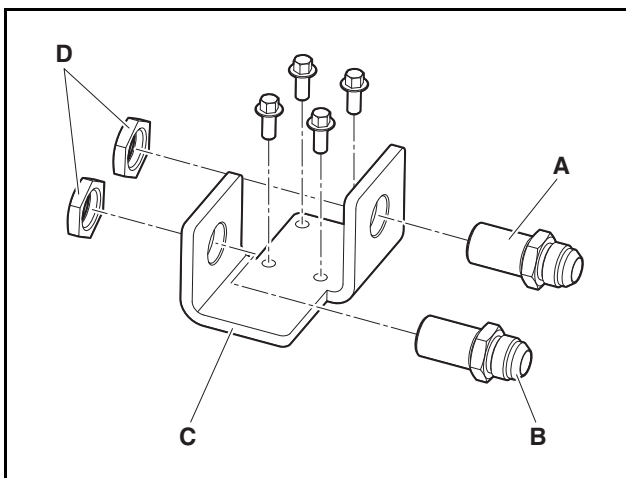

EDX15240105

- When tightening the adapters, note the direction of assembly to enable the adapters to slide along the grooves in the bracket joint. The engine fuel pipe inlet/outlet port bracket is installed on the engine oil filter head; use four M8 x 1.25 x 20 mm (0.7874 in.) bolts to tighten it to the specified torque.

Torque	2.20 ±0.55 kgf·m (15.9126 ±3.9782 lbf·ft)
--------	---

A	Fuel outlet port adapter
B	Fuel inlet port adapter
C	Engine fuel inlet/outlet port bracket
D	adapter

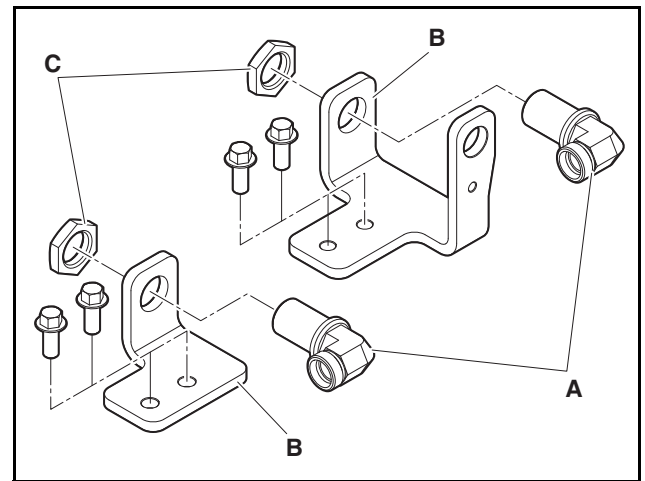

EDX15240084

- When tightening the adapters, note the direction of assembly to enable the adapters to slide along the grooves in the bracket joint. The upper engine fuel pipe port bracket is installed on the top of the engine timing gear case; use four M10 x 1.5 x 25 mm (0.9843 in.) bolts to tighten it to the specified torque.

Torque	6.20 ±1.55 kgf·m (44.8447 ±11.2112 lbf·ft)
--------	--

A	Upper engine fuel pipe adapter
B	Upper engine fuel pipe adapter bracket
C	nut (tightening torque: 9.5 ±0.95 kgf·m (68.7137 ±6.8714 lbf·ft))

## 8. Fuel System

---

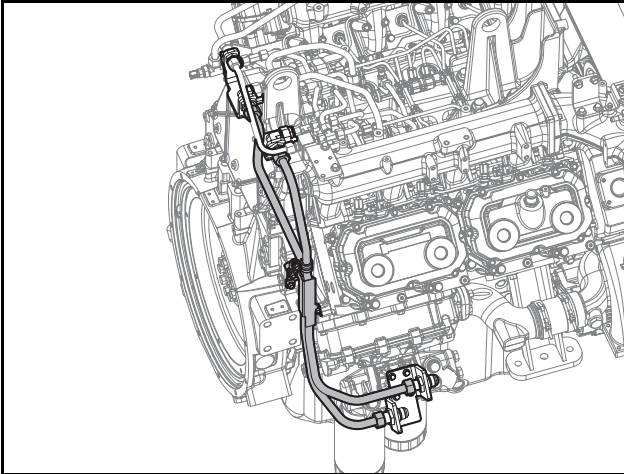

EDX15240085

3. Installing the engine fuel pipes: Install the fuel pipes from the engine fuel pipe inlet/outlet port adapters to the upper engine fuel pipe adapters at the specified torque.

Torque	6.20 ±1.55 kgf·m (44.8447 ±11.2112 lbf·ft)
--------	---

During this step, make sure to secure each pipe by tightening clips on the top of the upper engine fuel pipe adapter bracket and the side of the flywheel housing. Then, use two M8 x 1.25 x 20 mm (0.7874 in.) bolts to tighten the heat shield for protecting the pipes to the specified torque.

Torque	2.20 ±0.55 kgf·m (15.9126 ±3.9782 lbf·ft)
--------	--

---

### CAUTION

**Note the direction when installing clips on the fuel pipes. The clips must be installed so that the bolt heads can be seated on top of the clips.**

---

## Low-Pressure Fuel Pump

Refer to the following figure for information on the layout of low-pressure fuel lines, the fuel flow direction, and the pressure range of each fuel line in normal operating conditions.

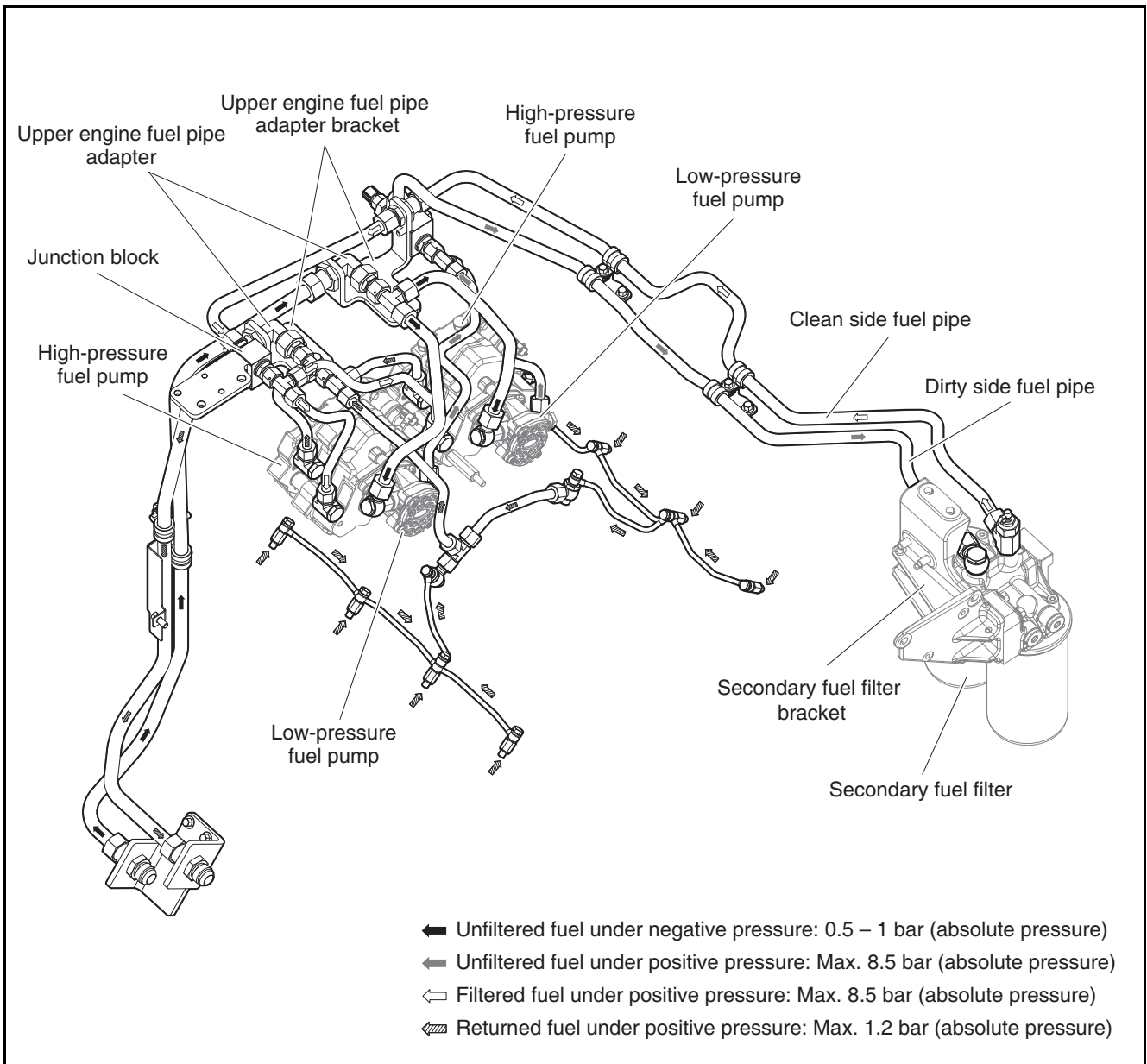

EDX15240090

## Components

The low-pressure fuel pump is integrated with the high-pressure fuel pump. The low-pressure fuel pump on bank no. 1 consists of two sets of adapters and sealing washers for connecting fuel lines to the fuel inlet/outlet ports, while the low-pressure pump on bank no. 2 consists of one set of an adapter and sealing washer for connecting the fuel line to the fuel inlet port.

# 8. Fuel System

## Installation

1. Installing the low-pressure fuel pump adapter for bank no. 1

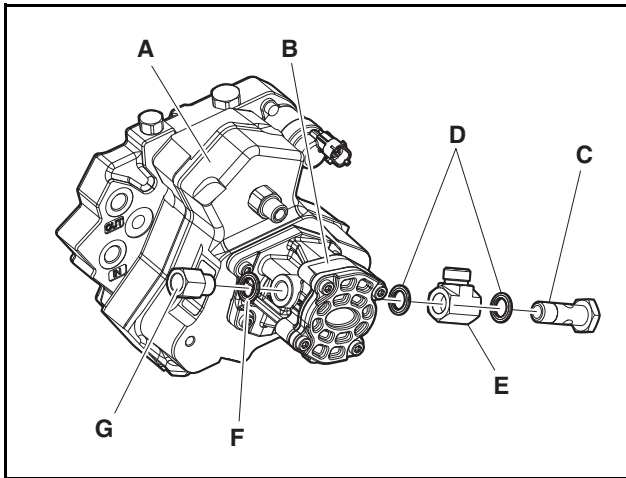

EDX22230119

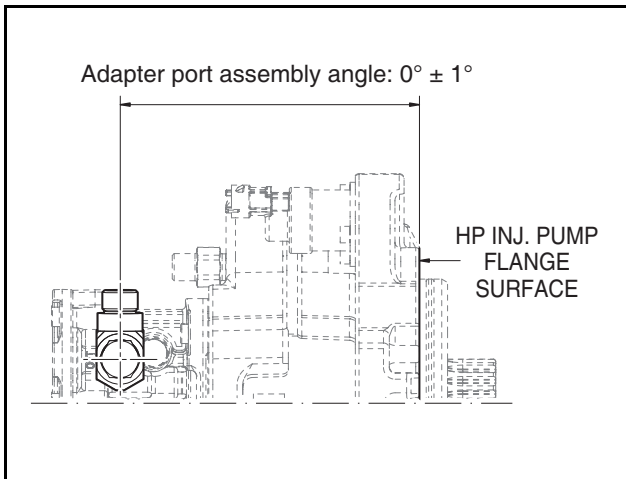

EDX22190210

1) After temporarily tightening the fuel inlet port adapter to the low-pressure fuel pump inlet with the sealing washer, tighten it to the specified torque.

Then, after temporarily tightening the fuel outlet port adapter to the low-pressure fuel pump outlet with the sealing washer, tighten it to the specified torque.

During this step, make sure that the angle of the adapter port is parallel to the flange of the high-pressure fuel pump.

Torque	Low-pressure fuel pump fuel inlet port adapter	2.5 ±0.2 kgf·m (18.0825 ±1.4466 lbf·ft)
	Low-pressure fuel pump fuel outlet adapter hollow screw	2.5 ±0.2 kgf·m (18.0825 ±1.4466 lbf·ft)

A	High-pressure fuel pump of bank no. 1
B	Low-pressure fuel pump of bank no. 1
C	Hollow screw of fuel outlet port of low-pressure fuel pump
D	Sealing washer of fuel outlet port of low-pressure fuel pump
E	Fuel outlet port adapter of low-pressure fuel pump
F	Sealing washer of fuel inlet port of low-pressure fuel pump
G	Fuel inlet port adapter of low-pressure fuel pump (SW19)

2. Installing the low-pressure fuel pump adapter of bank no. 2

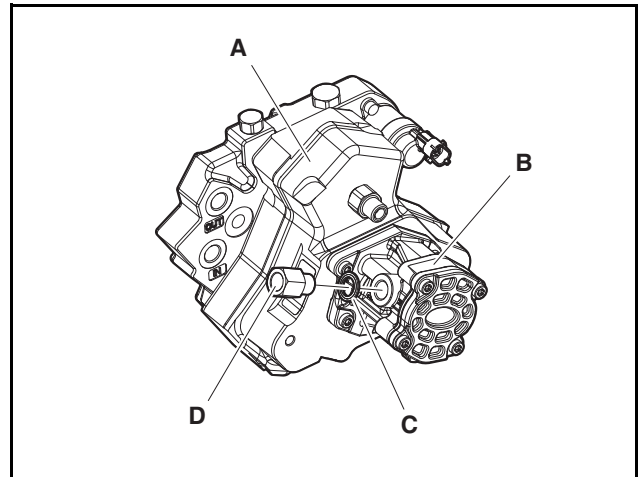

EDX22230120

1) After temporarily tightening the fuel inlet port adapter to the low-pressure fuel pump inlet with the sealing washer, tighten it to the specified torque.

Torque	Low-pressure fuel pump fuel inlet port adapter	2.5 ±0.2 kgf·m (18.0825 ±1.4466 lbf·ft)
--------	--	--

A	High-pressure fuel pump of bank no. 2
B	Low-pressure fuel pump of bank no. 2
C	Sealing washer of fuel inlet port of low-pressure fuel pump
D	Fuel inlet port adapter of low-pressure fuel pump (SW19)

## Secondary Fuel Filter

### Components

1. The secondary fuel filter consists of the fuel filter head and two fuel filter cartridges.

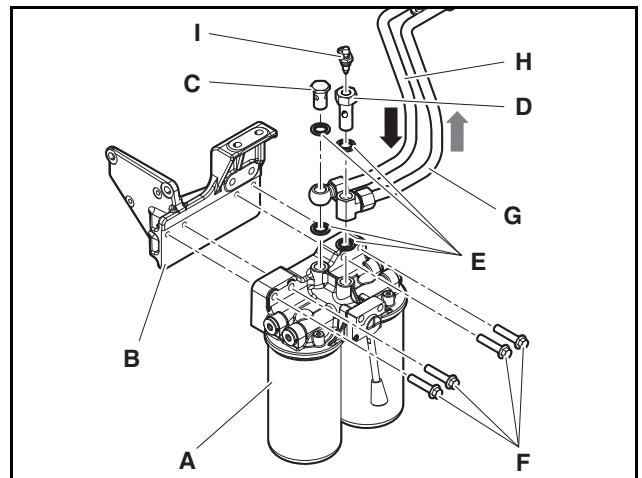

EDX15240086

A	Secondary fuel filter
B	Secondary fuel filter bracket
C	Fuel pipe hollow screw

D	Fuel pipe hollow screw (M18 x 1.5)
E	Fuel pipe sealing washer
F	Bolts (M10 x 1.5 x 50 mm (1.9685 in.))
G	Fuel pipe on dirty side
H	Fuel pipe on clean side
I	Bleeder nipple

## Installation

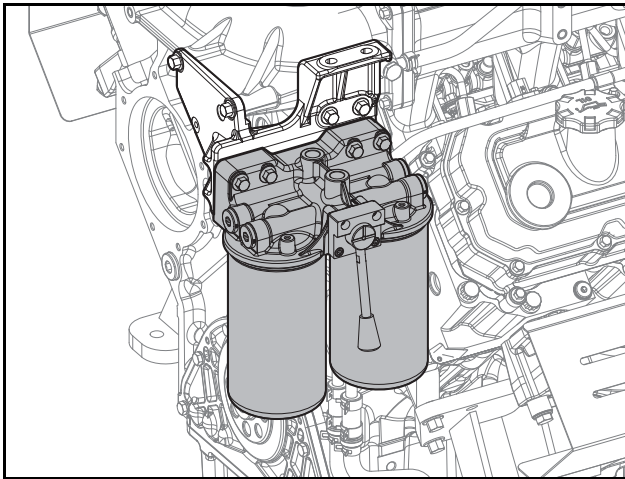

EDX15240098

- The fuel filter is secured to the fuel filter bracket located on the side of the engine oil pan with four M10 x 1.5 x 50 mm (1.9685 in.) bolts. After temporarily tightening the four bolts, tighten them to the specified torque.

Torque	6.20 ±1.55 kgf·m (44.8447 ±11.2112 lbf·ft)
--------	---

Then, use the hollow screws and sealing washers to tighten the fuel inlet/outlet pipes in the grooves in the top of the filter head.

Torque	5.5 ±0.55 kgf·m (39.7816 ±3.9782 lbf·ft)
--------	---

## Operation

The replacement intervals of the secondary fuel filter cartridge differ depending on the ESP, PRP and COP operating conditions. Make sure to comply with the replacement intervals suited to the operating conditions.

- Use a filter wrench to turn and loosen the fuel filter cartridge in the counterclockwise direction.
- Wipe the filter contact surface thoroughly.
- Apply a thin layer of engine oil to the O-ring and add fuel to the new filter.
- Install the O-ring on the sealing surface and tighten the cartridge another 3/4 ~ 1 turn.

## High-Pressure Fuel Pump

### Components and Functions

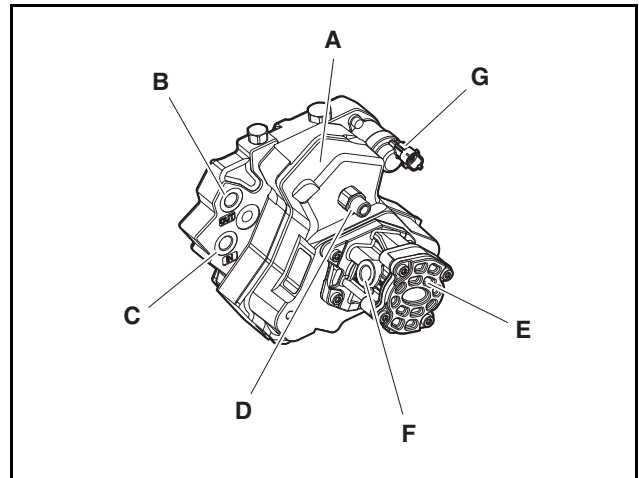

EDX22190213

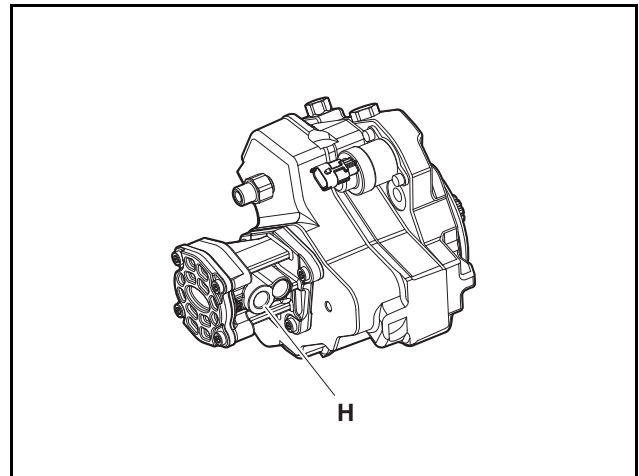

EDX22190214

- The high-pressure fuel pump consists of the pump body, the low-pressure fuel pump, and the metering unit. The high-pressure fuel pump pressurizes fuel from the low-pressure fuel pump and secondary fuel filter to the high pressures (DX15: 1,800 bar) required for engine operation and supplies this high-pressure fuel to the common rail and injectors.

The metering unit controls the amount of fuel supplied to the common rail depending on the engine load conditions.

A	High-pressure fuel pump
B	High-pressure fuel pump return fuel outlet (To. Engine fuel outlet port)
C	High-pressure fuel pump inlet (From. Secondary fuel filter)
D	High-pressure fuel pump inlet (To. Common rail)
E	Low-pressure fuel pump
F	Low-pressure fuel pump inlet (From. Engine fuel inlet port)

## 8. Fuel System

G	Metering unit
H	Low-pressure fuel pump outlet (To. Secondary fuel filter)

### Installation

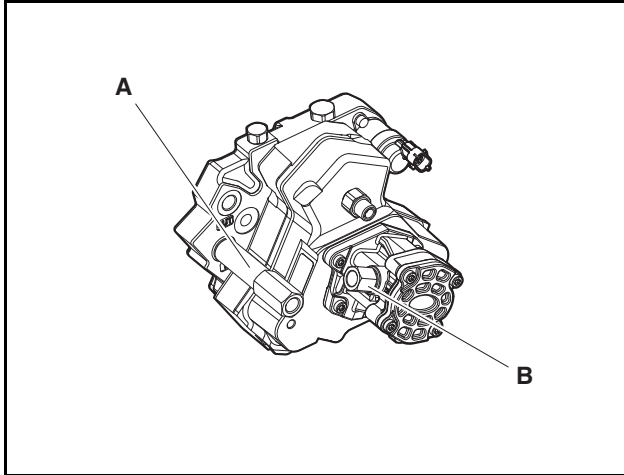

EDX22190215

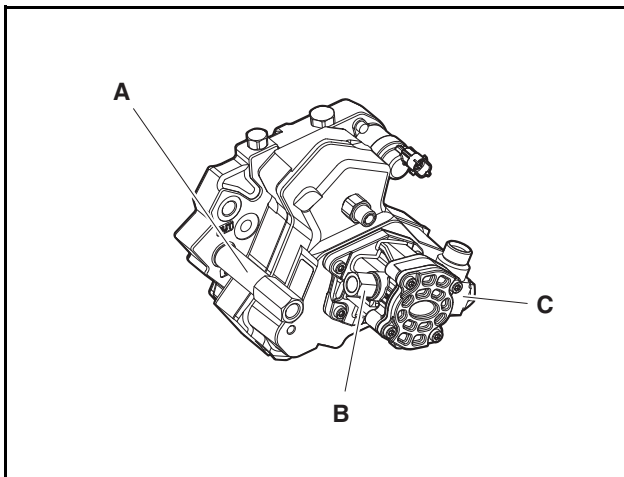

EDX22190216

1. The pumps are secured to the timing gear case on top of the engine flywheel with three bolts each.

The high-pressure fuel pump is connected to various pipes, including the high-pressure fuel pipe and fuel return pipe. Each pipe connecting port must be connected to the correct adapter and pipe in the correct order of assembly. (Refer to the order of assembly of low-pressure fuel pipes)

The metering unit must be connected to connectors for receiving ECU signals.

A	High-pressure fuel pump fuel delivery pipe adapter
B	Low-pressure fuel pump fuel drain pipe adapter
C	Low-pressure fuel pump fuel delivery pipe adapter

### Common Rail

#### Components and Functions

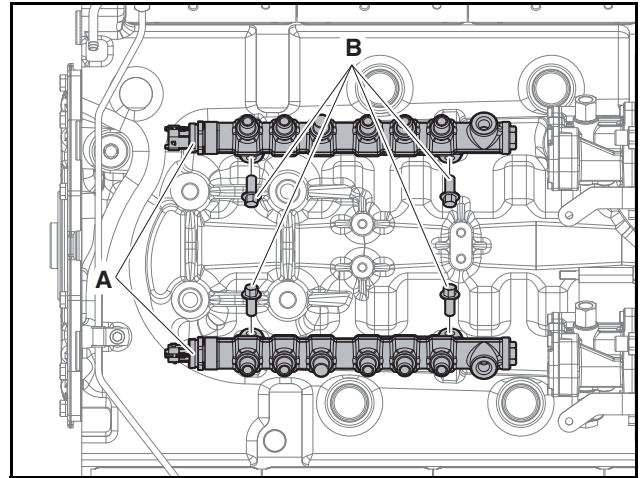

EDX15240087

1. The common rails consist of the common rail body, pressure sensor, and pressure limiter valve. The common rails maintain a constant fuel pressure (DX15: 1,800 bar) required by the injectors for fuel injection regardless of the engine load and operating mode.

A	Common rail
B	Bolts (M8 x 1.25 x 20 mm (0.7874 in.))

#### Installation

1. Tighten the common rails securely with two bolts each.

Torque	Common rail mounting bolts	2.20 ±0.55 kgf-m (15.9126 ±3.9782 lbf-ft)
--------	----------------------------	--

### High-Pressure Fuel Pipe

#### Components and Functions

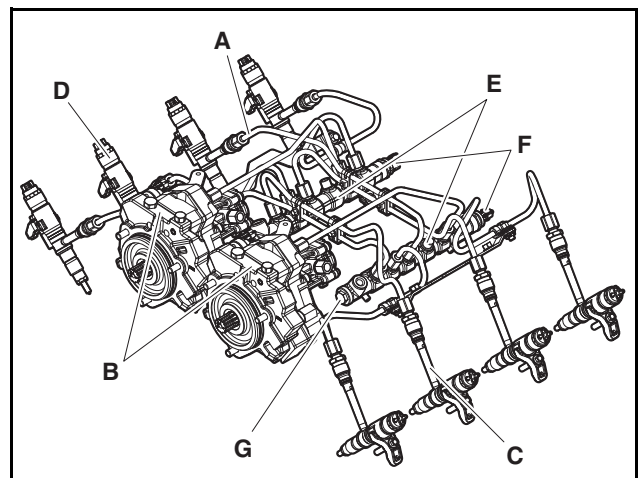

EDX15240088

- The high-pressure fuel pipes consist of pipes for transporting fuel, nuts for securing the pipes, and washers for dispersing stress between the nuts and pipes. They serve to deliver high-pressure fuel compressed in the common rails to the injectors.

A	High-pressure fuel pipe
B	High-pressure fuel pump
C	High-pressure fuel connector
D	Injectors
E	Common rail
F	Rail pressure sensor
G	Rail pressure limiter valve

### Installation

- After temporarily tightening the fuel pipes for each cylinder between the common rails and high-pressure fuel connectors, tighten them to the specified torque.

Torque	High-pressure fuel pipe	4 ±0.4 kgf·m (28.9321 ±2.8932 lbf·ft)
	High-pressure fuel connector	2.05 ±0.25 kgf·m (14.8277 ±1.8083 lbf·ft)

Then, install the mounting clips between each high-pressure fuel pipe.

Torque	High-pressure fuel pipe Clip mounting bolt	1 ±0.1 kgf·m (7.2330 ±0.7233 lbf·ft)
--------	---	---

### Injectors, High-Pressure Fuel Connectors

#### Components and Functions

The injectors serve to inject fuel into the combustion chamber by controlling the solenoid valves based on signals from the ECU. The high-pressure fuel connectors consist of the connector body, edge filter, and O-ring for preventing leaks in the return fuel. The connectors are used to deliver fuel from the high-pressure fuel pipes to the injectors through connections between the high-pressure fuel pipes and injectors.

### CAUTION

**When installing a new high-pressure fuel pipe after disconnecting the high-pressure fuel pipe connected to a high-pressure fuel connector (HPC), make sure to retighten the HPC mounting nuts to the specified torque. In addition, do not reuse high-pressure fuel pipes as the seal for high-pressure fuel is deformed while tightening them.**

### Installation

- Clean all parts thoroughly, taking care not to contaminate them with foreign matter.

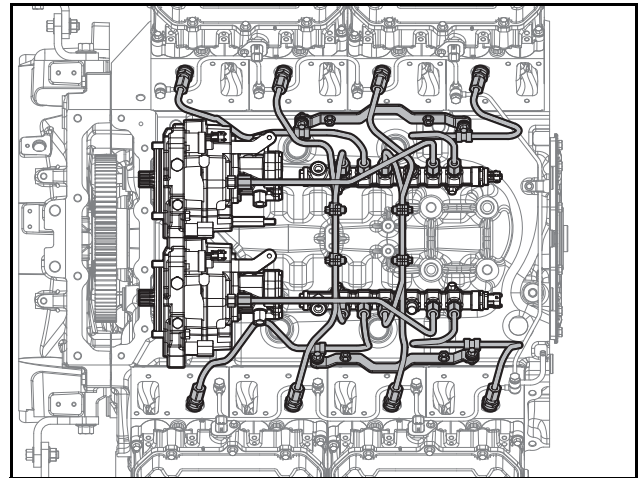

EDX15240089

- Fuel lines connecting the common rail to the injectors require particular cleanliness as they lack a filtration function.
- Clean and remove all foreign matter from the holes drilled in the cylinder head for inserting high-pressure fuel connectors and holes for injectors.
- When the injector is disassembled, the high-pressure fuel connector must be replaced with a new one.
- In the event that fuel accumulated in the fuel return line enters the combustion chamber while disassembling the injector, it must either be sucked out using a hand pump or discharged by cranking the starter motor with the fuel shut off.

## 8. Fuel System

---

# 9. Intake/Exhaust System

General Information .....	123
General Information .....	123
Turbocharger .....	123
Specifications .....	123
Structure .....	123
Overview .....	124
Function .....	124
Failure Diagnosis .....	125
Handling the Turbocharger .....	127
Check Items During Turbocharger Disassembly and Assembly .....	129
Inspecting the Turbocharger .....	130



# 9. Intake/Exhaust System

## General Information

### General Information

HD Hyundai Infracore engines are designed to satisfy stringent emissions regulations and are equipped with the full range of HD Hyundai Infracore technologies for enhancing fuel economy and reducing emissions.

### Turbocharger

### Specifications

Model	DX15
Engine power	995 kW/1,800 RPM
Turbocharger model (HOLSET No.)	HE500FG
Intake air amount	33.5 m <sup>3</sup> /min (1183.04 ft <sup>3</sup> /min)

### Structure

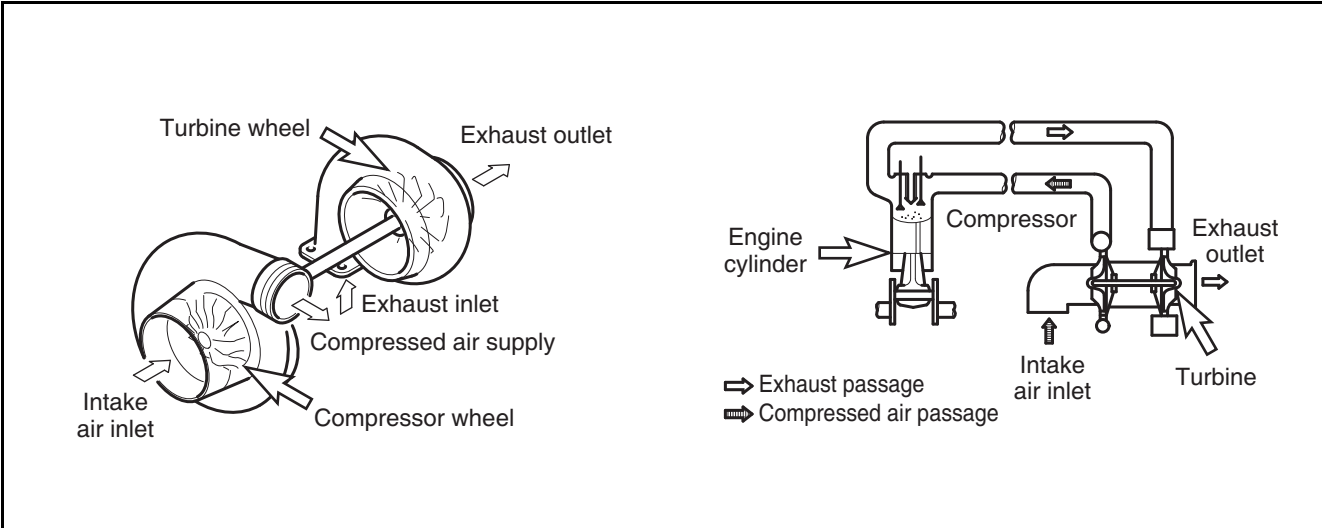

EDX22190037

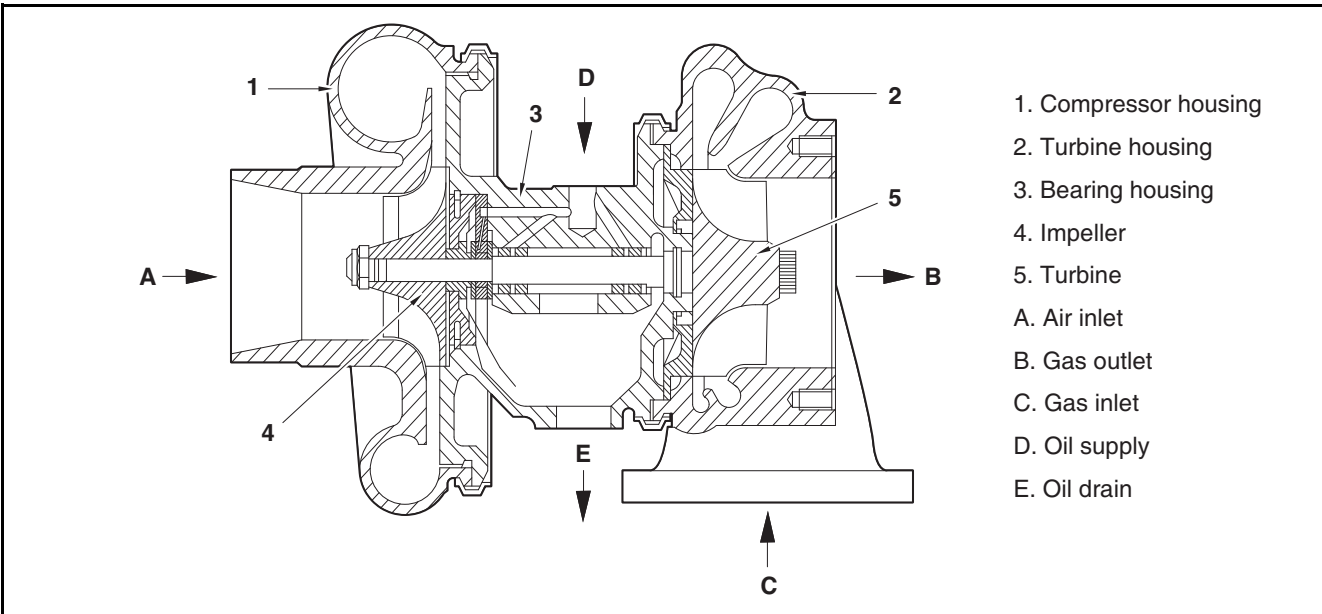

EDX22190240

## 9. Intake/Exhaust System

---

### Overview

The engine power is determined by the amount of fuel delivered and the engine efficiency. In order to burn the supplied fuel completely and convert it into effective work for the engine, a sufficient amount of air should be supplied for complete fuel combustion. Therefore, engine power is actually determined by the volume of the cylinders. If compressed air is delivered to cylinders of a given volume, the amount of air in the cylinders increases, enabling more fuel to be burnt and increasing power. Compressing air and delivering it to the engine cylinders in this way is referred to as supercharging, while supercharging air using the energy of exhaust gas discharged into the atmosphere is known as turbocharging.

### Function

#### 1. Turbine

As exhaust gas discharged from the combustion chamber passes through the turbine housing, its energy is transferred to the turbine blades, thereby rotating the turbine shaft. This turbine device is equipped with a seal ring and heat shield to prevent exhaust gas from affecting the bearing negatively.

#### 2. Compressor

As it is connected to the same shaft as the turbine and forms a single rotating unit, it receives rotating force from the turbine shaft to suck in, compress and supply air to the intake manifold. This is known as the compressor.

#### 3. Bearing

Axial force acts on the thrust bearing turbine to keep the shaft from moving.

The journal bearing is a floating bearing which, unlike regular fixed bearings, forms a dual oil film on the inner and outer surfaces of the bearing to enable the bearing to rotate independently. The dual oil film acts as a damper which keeps the sliding speed on the bearing surface lower than the shaft rotation speed, thereby ensuring dynamic stability.

#### 4. Compressor shaft seal ring

The seal plate and seal ring are composed of dual structures to prevent compressed intake air and lubricant from leaking.

## 9. Intake/Exhaust System

### Failure Diagnosis

Symptom	Possible Cause	Troubleshooting
Noise or vibrations	Contact with rotating part	Repair or replace
	Unevenly rotating rotor	Repair or replace
	Seizure	Repair or replace
	Loose connection	Check or repair
	Deformed or damaged intake unit hose	Replace
	Incorrectly tightened clamp	Adjust and tighten
	Contaminated or damaged air filter	Replace and check the turbocharger impeller for damage
	Turbocharger coolant leak or oil hose leak	Replace the hose and gasket
	Gas leaking from the exhaust manifold	Replace the gasket or tighten the mounting nuts
	Turbo actuator operating poorly	Replace the turbocharger
	Leaking engine block and exhaust manifold	Check the engine
	Contaminated blow-by gas and incorrect oil level	Check the turbo impeller and turbo intake outlet
	Interference with the wall due to excessive free play of turbocharger wheel	Check for sand or metallic foreign matter
	Damaged turbocharger wheel	Check for sand or metallic foreign matter
	Damaged turbocharger wheel and shaft	Check for sand or metallic foreign matter
Poor rotating force of the turbocharger wheel	Check for sand or metallic foreign matter	
Reduced power	Gas leaking from the exhaust system	Check or repair
	Clogged air filter element	Clean or replace
	Contaminated or damaged turbocharger	Repair or replace
	Air leaking from outlet of compressor shaft	Check or repair
	Deformed or damaged intake unit hose	Replace
	Incorrectly tightened clamp	Adjust and tighten
	Contaminated or damaged air filter	Replace and check the turbocharger impeller for damage
	Turbo actuator operating poorly	Replace the turbocharger
	Leaking engine block and exhaust manifold	Check the engine
	Contaminated blow-by gas and incorrect oil level	Check the turbo impeller and turbo intake outlet
	Interference with the wall due to excessive free play of turbocharger wheel	Check for sand or metallic foreign matter
	Damaged turbocharger wheel	Check for sand or metallic foreign matter
	Damaged turbocharger wheel and shaft	Check for sand or metallic foreign matter
Poor rotating force of the turbocharger wheel	Check for sand or metallic foreign matter	
Oil leak	Deformed or damaged intake unit hose	Replace
	Incorrectly tightened clamp	Adjust and tighten
	Contaminated or damaged air filter	Replace and check the turbocharger impeller for damage
	Turbocharger coolant leak or oil hose leak	Replace the hose and gasket
	Turbo actuator operating poorly	Replace the turbocharger
Oil leak	Leaking engine block and exhaust manifold	Check the engine
	Contaminated blow-by gas and incorrect oil level	Check the turbo impeller and turbo intake outlet
	Interference with the wall due to excessive free play of turbocharger wheel	Check for sand or metallic foreign matter
	Damaged turbocharger wheel	Check for sand or metallic foreign matter
	Damaged turbocharger wheel and shaft	Check for sand or metallic foreign matter
	Poor rotating force of the turbocharger wheel	Check for sand or metallic foreign matter

## 9. Intake/Exhaust System

Symptom	Possible Cause	Troubleshooting
Oil consumption	Incorrectly tightened clamp	Adjust and tighten
	Turbocharger coolant leak or oil hose leak	Replace the hose and gasket
	Leaking engine block and exhaust manifold	Check the engine
	Contaminated blow-by gas and incorrect oil level	Check the turbo impeller and turbo intake outlet
	Interference with the wall due to excessive free play of turbocharger wheel	Check for sand or metallic foreign matter
	Damaged turbocharger wheel	Check for sand or metallic foreign matter
	Damaged turbocharger wheel and shaft	Check for sand or metallic foreign matter
	Poor rotating force of the turbocharger wheel	Check for sand or metallic foreign matter
Black or white exhaust smoke	Deformed or damaged intake unit hose	Replace
	Contaminated or damaged air filter	Replace and check the turbocharger impeller for damage
	Turbocharger coolant leak or oil hose leak	Replace the hose and gasket
	Turbo actuator operating poorly	Replace the turbocharger
	Contaminated blow-by gas and incorrect oil level	Check the turbo impeller and turbo intake outlet
	Interference with the wall due to excessive free play of turbocharger wheel	Check for sand or metallic foreign matter
	Damaged turbocharger wheel	Check for sand or metallic foreign matter
	Damaged turbocharger wheel and shaft	Check for sand or metallic foreign matter
	Poor rotating force of the turbocharger wheel	Check for sand or metallic foreign matter
Blue exhaust smoke	Leaking engine block and exhaust manifold	Check the engine
Excessive white smoke	Oil leaking into turbine or compressor	Repair or replace
	Worn or damaged seal ring due to excessively worn bearing	Repair or replace
Excessive exhaust smoke	Clogged air filter element	Clean or replace
	Clogged air duct	Check or repair
	Air leaking from the intake system	Check or repair
	Seized turbocharger (impossible to rotate)	Repair or replace
	One turbine blade or compression blade is in contact with another or is damaged	Repair or replace
	Deformed or clogged exhaust system pipe	Check or repair

### Handling the Turbocharger

1. Cautions for engine operation

1) Follow the instructions below when starting, running and stopping the engine:

Item	Caution	Reason
When starting the engine	Check the oil level	
	Before starting the engine, make sure to run it with the starter motor to check for a rise in hydraulic pressure (until the needle on the hydraulic pressure gauge moves or the pressure indicator turns on).	If the engine is started abruptly, oil cannot reach the turbocharger or the various parts of the engine; this lack of lubrication can lead to abnormal wear or seizure of the bearings.
	After changing the oil, replacing the oil filter cartridge or lubrication system component or leaving the engine stopped for an extended period of time or in cold weather, undo the oil pipe connection at the inlet of the turbocharger and run the starter motor until oil flows out of it. Once this step is complete, make sure to retighten the pipe connection and start the engine.	Oil flow in pipes worsens after the engine has been stopped for a prolonged period of time or in cold weather.
Immediately after starting the engine	Idle the engine for 5 minutes after starting it.	If the engine is overloaded abruptly right after being started, the engine and turbocharger are still not rotating freely and the lack of lubrication can lead to seizure of parts.
	Check each part for oil leaks, gas leaks and air leaks, and take any necessary measures to resolve the issues.	Oil leaks, gas leaks and air leaks (especially oil leaks) can reduce hydraulic pressure, and oil loss can cause bearings to seize up.
During operation	Check the following:	
	Hydraulic pressure During idling : 1.5 ~ 3.0 kg/cm <sup>2</sup> (21.335 ~ 42.7 psi) Under a full load : 3.0 ~ 5.5 kg/cm <sup>2</sup> (42.7 ~ 78.2 psi)	Excessively low oil pressure can lead to abnormal wear or seizure of bearings. If oil pressure is excessively high, it can cause oil leaks.
	If abnormal noise or vibrations occur, lower the speed slowly and stop the engine to locate the cause.	Continuing to drive with abnormal noise or vibrations can severely damage the engine beyond repair.
When stopping	Before stopping the engine, idle the engine for 5 minutes first.	Stopping the engine abruptly after overloaded operation causes heat to be transferred from the hot turbine blades to the bearings. Since this heat burns the oil on the bearings, the metal bearings and rotating shaft may seize up.

2. Cautions for handling

- 1) If the engine rpm is increased abruptly after starting the engine, the crankshaft rotates at an excessive speed before the crankshaft journal bearing has been lubricated sufficiently. If the turbocharger rotates in this state, bearings may seize up due to the lack of cooling and lubrication, leading to damage in related parts.
- 2) After replacing the engine oil or oil filter, make sure to idle the engine for at least two minutes before driving to ensure that enough lubricant circulates throughout the turbocharger.
- 3) After operating the engine at a high speed for a prolonged period of time, idle the engine sufficiently before stopping it. Otherwise, the turbine wheel continues rotating without any hydraulic pressure in the turbocharger and an oil layer is not formed on the turbocharger center bearing and journal bearing, leading to wear and shortening of the turbocharger life.
- 4) In extremely cold temperatures or after a prolonged period of inactivity of the engine, idle the engine for a sufficient amount of time after starting it until the hydraulic pressure in the engine reaches a normal level.

## 9. Intake/Exhaust System

---

- 5) The turbocharger turbine spins at extremely high speeds of 50,000–200,000 rpm. Hence, the oil supply of bearings has a significant impact on the turbocharger life, so make sure to use genuine engine oil recommended by HD Hyundai Infracore and check and replace the engine oil periodically.
- 6) Using a contaminated air cleaner for a prolonged period of time can cause critical damage to the turbocharger, so make sure to check and replace the air cleaner regularly.
- 7) The turbocharger is a highly complex unit of precision machinery which should only be handled by certified technicians.
- 8) Operating the turbocharger without the intake or exhaust manifold installed may severely damage the engine or cause physical injuries to workers. The turbocharger must only be operated with all of the parts installed properly in their designated positions.
- 9) Do not grab the turbocharger actuator to lift the turbocharger. It can be damaged by the weight of the turbocharger.
- 10) The turbocharger is a heavy unit. When lifting the turbocharger to remove or mount it, workers should lower their center of gravity or hold the turbocharger closely. Otherwise, the turbocharger may fall, damaging the parts and causing physical injuries to workers.

## 9. Intake/Exhaust System

### Check Items During Turbocharger Disassembly and Assembly

No.	Check Items	Reason						Troubleshooting
		Noise	Power Drop	Oil Leak	Oil Cons.	Black/White Exhaust Smoke	Blue Exhaust Smoke	
Before removal								
1	Are any hoses in the intake system torn or deformed?	o	o	o		o		Replace the hose
2	Are clamps tightened properly?	o	o	o	o			Retighten the bolts and nuts
3	Is the air filter in good condition?	o	o	o		o		Replace the air filter Check the turbocharger impeller for damage
4	Are there any leaks in the turbocharger coolant or oil hoses?	o		o	o	o		Replace the hose and gasket
5	Is gas leaking from the exhaust manifold gasket?	o						Replace the nuts and gasket
6	Is the turbocharger actuator operating normally?	o	o	o		o		Replace the turbocharger
During removal								
1	Are there any traces of leaks between the engine block and exhaust manifold?	o	o	o	o		o	Check the engine
2	Is there any foreign matter in the blow-by gas? Is the oil level normal?	o	o	o	o	o		Check the turbo impeller and turbo intake outlet
3	Are there any traces of interference with the wall due to excessive free play of the wheel?	o	o	o	o	o		Check for foreign matter (Sand, metallic matter)
4	Is the wheel damaged?	o	o	o	o	o		Check for foreign matter (Sand, metallic matter)
After removal								
1	Is the wheel damaged or is the shaft split?	o	o	o	o	o		Check for foreign matter (Sand, metallic matter)
2	Is the wheel rotating properly?	o	o	o	o	o		

## 9. Intake/Exhaust System

### Inspecting the Turbocharger

#### 1. Daily inspection and service

Turbocharger performance depends largely on the state of engine maintenance.

Hence, it is important to maintain the engine as instructed.

#### 1) Intake system

In the intake system, pay attention to the maintenance of the air filter. For a wet-type air filter, if the oil level is below the specified level, the filtering performance is degraded. On the other hand, if the oil level is too high, the filter sucks in oil, contaminating its case. In particular, if the rotor is contaminated, the finely tuned balance is lost, causing vibrations. In addition, a massive load is applied to the bearing, causing seizure and abnormal wear. Thus, use of the air filter is essential for full use and service of the machine. For a dry-type air filter, intake air resistance should be as low as possible.

#### 2) Exhaust system

In the exhaust system, if exhaust gas leaks from the exhaust manifold or turbocharger connection, the turbocharger performance is degraded. Hence, particular care should be taken to prevent gas leaks and seizure. Since heat-resistant steel nuts are used for components that become hot during operation, such as the turbine chamber, these nuts should not be confused with other general nuts. In addition, mounting nuts should be coated with an anti-sticking agent if specified.

#### 3) Lubrication system

In the lubrication system, pay attention to the oil quality and oil filter cartridge replacement intervals. Degraded engine oil can affect the turbocharger as well as the engine itself adversely.

#### 2. Periodic inspection and service

The condition and contamination of the turbocharger should be checked regularly.

#### 1) Inspecting the rotation of the rotor

To check the rotating state of the rotor, listen for any abnormal noise during rotation.

If a sound rod is used, touch the tip of the rod to the turbocharger housing and rev up the engine slowly.

If a high-pitched noise persists, there is a problem with the part.

In this case, the bearing or rotor may be operating abnormally, so the turbocharger must either be replaced or repaired.

#### 2) Checking the free play of the rotor

Remove the turbocharger from the engine and check both the axial and radial play of the rotor.

When removing the turbocharger, make sure to seal the oil inlet and outlet with tape, etc.

During rotation, the wheel must rotate smoothly without any interference.

#### • Rotor axial play

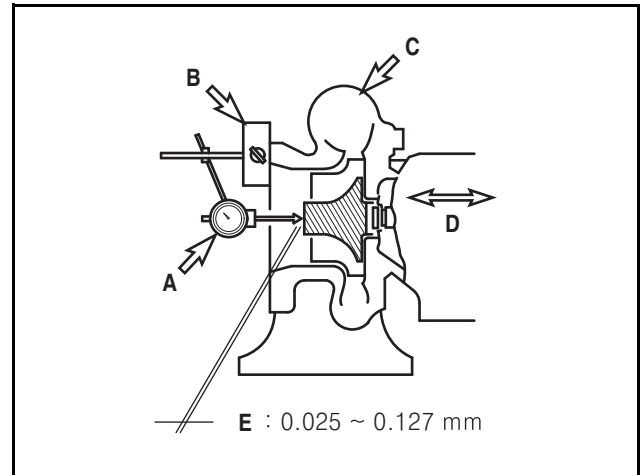

EDL08190025

- A. Dial gauge
- B. Magnetic vice
- C. Turbine chamber
- D. Move the turbine shaft in the axial direction.
- E. Maintenance standard (0.025 ~ 0.127 mm / 0.00098 ~ 0.005 in.)

#### • Rotor radial play

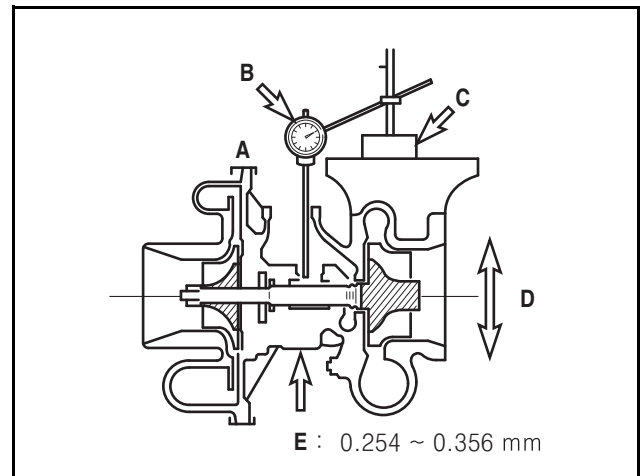

EDL08190026

- A. Oil outlet
- B. Dial gauge
- C. Magnetic vice
- D. Move the turbine shaft side to side in the radial direction simultaneously.
- E. Maintenance standard for radial play (0.254 ~ 0.356 mm / 0.01 ~ 0.014 in.)

- If the axial or radial play exceeds the wear limit, either replace the turbocharger or remove and repair it.
- 3) Removing and inspecting the turbocharger
  - Remove the turbocharger from the engine and clean or inspect it.
  - When doing so, make sure to seal the oil inlet and outlet with tape, etc.

### 4) Cautions for turbocharger assembly

When mounting the turbocharger on the engine or handling it after assembly, follow the instructions below. Take particular care to ensure that foreign matter does not enter the turbocharger.

- Lubrication system
  - Before mounting it on the engine, add fresh oil through the oil filler port and turn the turbine shaft by hand to lubricate the journal bearing and thrust bearing.
  - Wash the pipe between the engine and oil inlet and the pipe from the oil outlet; then, check them for damage or foreign matter.
  - Tighten each oil pipe connection firmly to prevent oil leaks.
- Intake system
  - Check the intake system for foreign matter.
  - Install connections securely so that there are no air leaks from the various connections in the intake system and air filter.
- Exhaust system
  - Check the exhaust system for foreign matter.
  - Use heat-resistant steel bolts and nuts and keep them separate from general bolts and nuts during assembly. Apply an anti-sticking agent to bolts and nuts.
  - Install exhaust system connections securely to prevent gas leaks.

## 9. Intake/Exhaust System

---

# 10. Cylinder Block/Head

General Information .....	135
General Information .....	135
Cylinder Block .....	136
General Inspection of the Cylinder Block.....	136
Cylinder Head .....	137
Assembling the Cylinder Head.....	137
Inspecting the Cylinder Head.....	138
Valves .....	139
General Information .....	139
Inspecting Valves.....	139
Inspecting the Valve Guide .....	139
Inspecting the Valve Seat .....	140
Inspecting the Valve Spring .....	141
Rocker Arms .....	142
Checking and Measuring the Assemblies.....	142
Assembling the Rocker Arms.....	142
Tappet and Pushrod .....	143
Tappet Clearance .....	143
Inspecting the Tappet Visually .....	143
Pushrod Deflection.....	143
Camshaft .....	144
Camshaft Play.....	144
Checking and Measuring the Camshaft.....	144
Replacing the Camshaft Bearing .....	145



### General Information

#### General Information

Equipped with an overhead valve and turbocharger, HD Hyundai Infracore diesel engines are electronically controlled and air-cooled by a cooling fan.

Pressurized fuel generated by the high-pressure fuel pump is stored in the common rail. When the operator uses the generator, the optimal amount of fuel and fuel injection timing are determined based on the data set in the electronic control unit (ECU) according to the vehicle speed and operating conditions, while the ECU actuates the solenoid valve for the injector installed in each cylinder of the engine to inject fuel into the cylinders.

The crankshaft is a single forged unit. The oil seals on the crankshaft and flywheel are designed to prevent oil from entering the flywheel.

The connecting rod is a single forged unit. Its big end can be disconnected in the vertical direction, enabling it to be removed with the piston through the top of the cylinder. The moving parts of the crankshaft and connecting rod are equipped with alloy bearings.

## 10. Cylinder Block/Head

---

### Cylinder Block

#### General Inspection of the Cylinder Block

1. Clean the cylinder block thoroughly and check it visually for cracks or damage.
2. If it is severely cracked or damaged, replace it with a new one; if the damage is minor, repair it.
3. Check the oil and coolant passages for clogging and corrosion.
4. Perform a hydrostatic test to check for cracks or air leaks.
5. Plug the coolant and oil outlets of the cylinder block and supply approx. 4 kg/cm<sup>2</sup> (57 psi) of pressure through the inlet; then, soak the cylinder block in 70°C (158°F) water for approx. one minute and check for air leaks.

# 10. Cylinder Block/Head

## Cylinder Head

1. Disassemble the cylinder head and keep the components on a shelf for later assembly.
2. Be careful not to damage the cylinder head gasket contact surface.
3. Remove the valve cotter, spring and spring seat using a valve spring compressor.

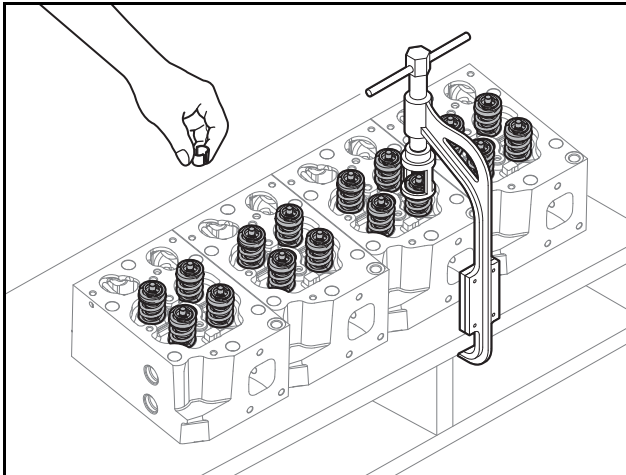

EDX15240091

4. Pull out the intake and exhaust valves.
5. Keep the removed parts in order.
6. Remove the valve stem seal.

### Assembling the Cylinder Head

1. Clean the cylinder head thoroughly.
2. Replace the valve stem seals with new ones.
3. Use a special service tool to insert the stem seal into the valve guide of the cylinder head.
4. Apply engine oil to the valve stem and valve guide; then, install the valve.

### CAUTION

**Be careful not to damage the valve stem seal.**

**Make sure to keep bolts free of oil.**

**Wipe any oil off bolts before using them.**

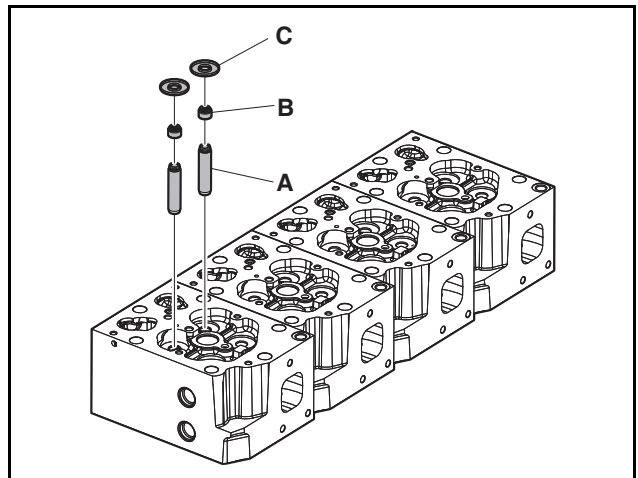

EDX15240092

5. Install the valve stem seal (B) on the valve guides (A) on top of the cylinder head.
6. Assemble the inner/outer valve springs; then, place the valve spring washer (C) on top.

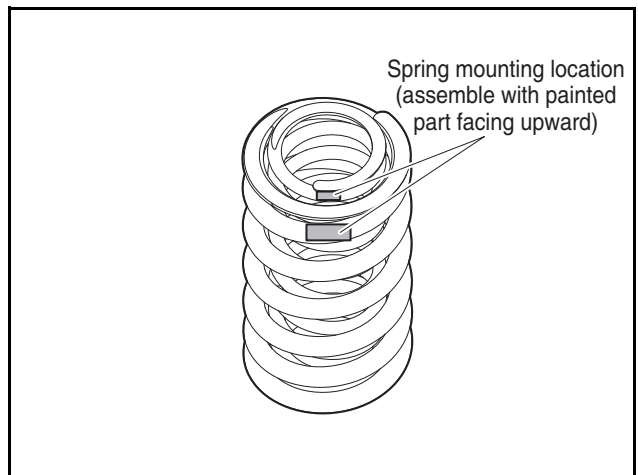

EDX22190169

7. Use a valve spring compressor to press the valve spring; then, insert the valve cotter and assemble the valve.
8. After assembling the valve, tap it with a urethane hammer gently to check that it has been assembled correctly.

# 10. Cylinder Block/Head

## Inspecting the Cylinder Head

1. Inspecting the Cylinder Head
  - 1) Remove carbon residue from the bottom of the cylinder head.

**⚠ CAUTION**

**Be careful not to scratch the valve seat surface.**

**Make sure to keep bolts free of oil.**

**Wipe any oil off bolts before using them.**

- 2) Check the cylinder head visually for damage.
  - 3) Perform a hydrostatic test or magnetic particle test to check for small cracks or damage that cannot be identified with the naked eye.
2. Bottom distortion
- 1) Measure the distortion of the cylinder head in six directions with a straightedge and feeler gauge.

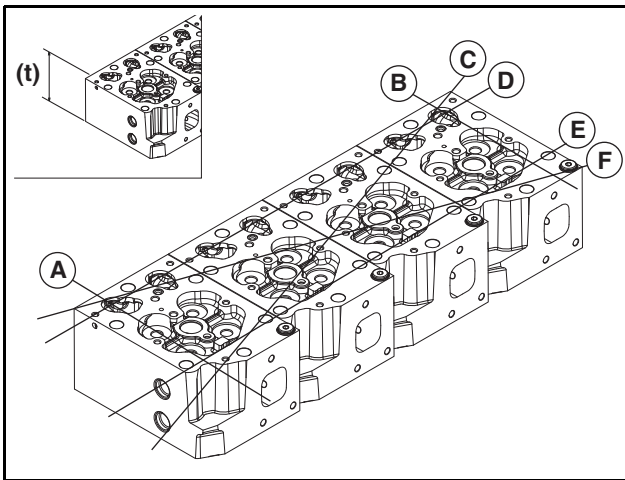

EDX15240093

- 2) If the measured result exceeds the allowable service limit, correct it using fine sandpaper or a grinder.
- 3) If the measurement exceeds the allowable limit, replace the cylinder head.

- Cylinder head distortion and height

	Reference value	Allowable limit
Flatness of bottom surface of cylinder head	0.015 mm (0.00059 in.) or less	0.03 mm (0.00118 in.)
Head height: t	116.95~117.05 mm (4.604 ~ 4.608 in.)	116.5 mm (4.587 in.)

### 3. Flatness

- 1) Measure the flatness of the intake/exhaust manifold mounting surface of the cylinder head with a straightedge and feeler gauge.

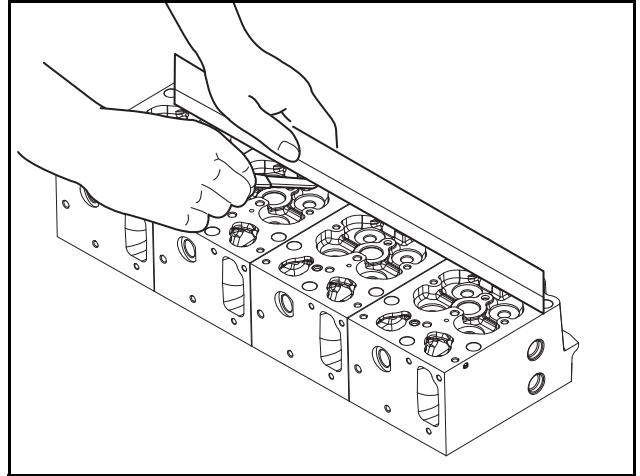

EDX15240094

Reference value	Allowable limit
0.015 mm (0.00059 in.) or less	0.03 mm (0.00118 in.)

### 4. The hydrostatic test

- 1) The hydrostatic test for the cylinder head is performed in the same way as the test for the cylinder block.

## Valves

### General Information

The overhead valve is operated by the tappets, pushrods and rocker arms on the camshaft.

### Inspecting Valves

Wash the valve with clean engine oil and inspect it as follows.

#### 1. Valve stem outside diameter

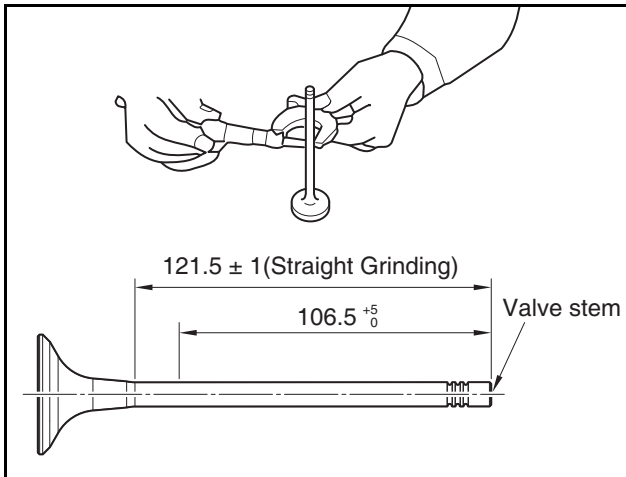

EDX22190170

- 1) Measure the valve stem outside diameter in three places (top, middle, bottom).
- 2) If the amount of wear exceeds the allowable limit, replace the valve.

	Reference value	Allowable limit
Intake valve stem	Ø7.963 ~ Ø7.977 mm (Ø0.3135 ~ Ø0.3141 in.)	Ø7.943 mm (Ø0.3127 in.)
Exhaust valve stem	Ø7.950 ~ Ø7.964 mm (Ø0.3129 ~ Ø0.3135 in.)	Ø7.920 mm (Ø0.3118 in.)

#### 2. Valve seat mating surface

- 1) Check the valve seat mating surface for scratches or damage.
- 2) If necessary, grind the surface with sandpaper. However, if the damage is severe, replace the part.

#### 3. Valve head thickness

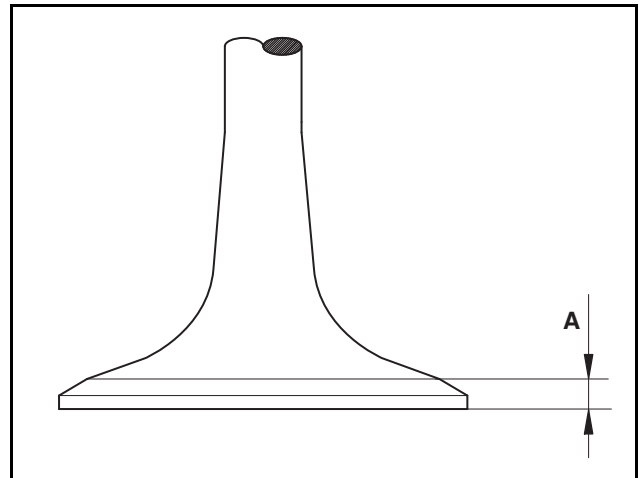

EE10M066

- 1) Measure the thickness of the valve head.
- 2) If the measurement is below the allowable limit, replace the valve.

	Reference value	Allowable limit
Intake valve (A)	3.2 ~ 3.6 mm (0.1260 ~ 0.1417 in.)	2.7 mm (0.1063 in.) or less
Exhaust valve (A)	3.9 ~ 4.3 mm (0.1535 ~ 0.1693 in.)	3.4 mm (0.1339 in.) or less

### Inspecting the Valve Guide

1. Install the valve on the cylinder head.
2. Measure the clearance between the valve guide and valve arising from the movement of the valve.

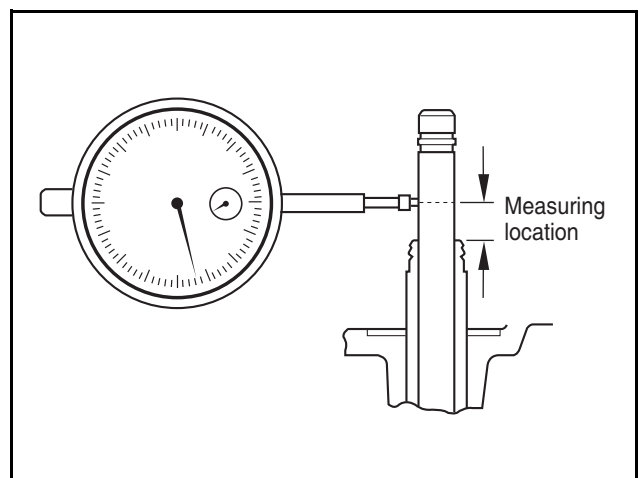

EA0M4052

# 10. Cylinder Block/Head

3. If the clearance is excessively large, measure the valve and replace either the valve or valve guide, whichever part is more worn.
  - Valve stem play

	Reference value	Allowable limit
Intake Valve	0.038 ~ 0.067 mm (0.0014 ~ 0.0026 in.)	0.10 mm (0.0039 in.)
Exhaust Valve	0.051 ~ 0.080 mm (0.002 ~ 0.0032 in.)	0.15 mm (0.0059 in.)

4. Install the valve on the cylinder head valve guide.
5. Use a special service tool to check whether the valve seat is aligned with the center.

## Inspecting the Valve Seat

1. Amount of contact with mating surface

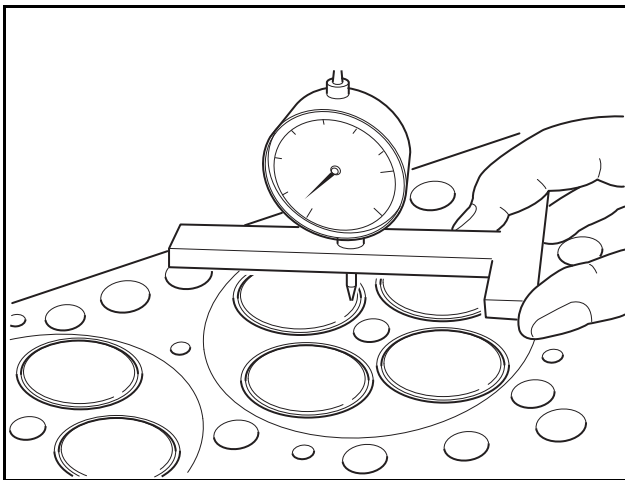

EE10M067

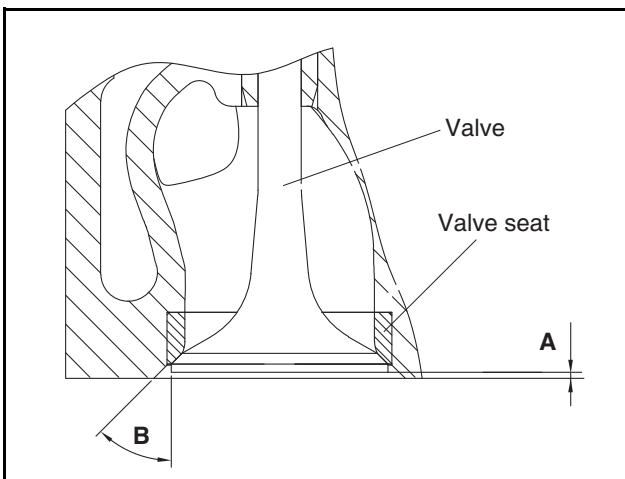

EE10M068

- 1) To check the amount of wear on the valve seat, measure the height of the mating surface between the intake and exhaust valve.
- 2) If the measurement exceeds the allowable limit, replace the part.

- 3) Install the valve on the cylinder head valve seat.
- 4) Use a dial gauge to measure the insertion length of the valve from the bottom of the cylinder head.
  - Valve step height

	Reference value	Allowable limit
Intake valve (A)	0.9 ~ 1.1 mm (0.0354 ~ 0.0433 in.)	1.3 mm (0.0512 in.)
Exhaust valve (A)	0.9 ~ 1.1 mm (0.0354 ~ 0.0433 in.)	1.6 mm (0.063 in.)

- Valve angle

Intake valve (B)	Exhaust valve (B)
60°	45°

- 5) If the insertion length of the valve exceeds the allowable limit, replace the valve seat.
- 6) To remove the valve seat, perform arc welding in two places on the valve seat; then, use a special service tool to pull out the valve seat.

Note) The inside diameter needs to be bored during the removal of the valve seat.

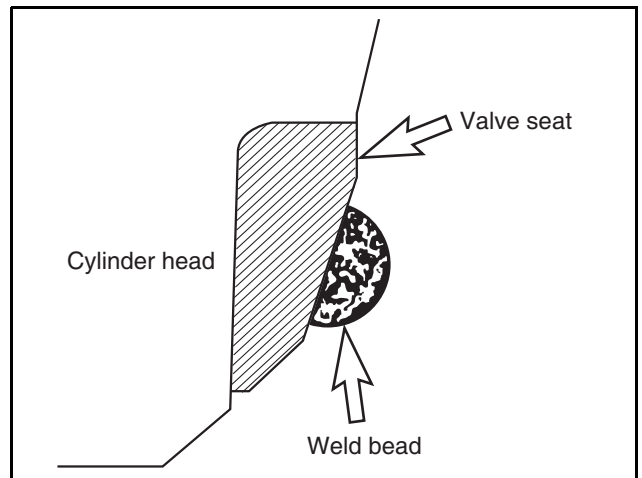

EA3M2032

- 7) Before assembling the valve seat, cool it in dry ice for approx. two hours.
- 8) Use a bench press to press-fit the valve seat into the cylinder head.
- 9) Apply abrasive to the valve head mating surface of the valve seat.
- 10) Turn the valve to polish the valve seat surface until the valve is properly seated. Then, remove the abrasive completely.

# 10. Cylinder Block/Head

## Inspecting the Valve Spring

1. Perform a visual inspection of the exterior of the valve spring.
- 1) Visually inspect the valve spring for external damage and replace it if necessary.
2. Check the free length of the valve spring.

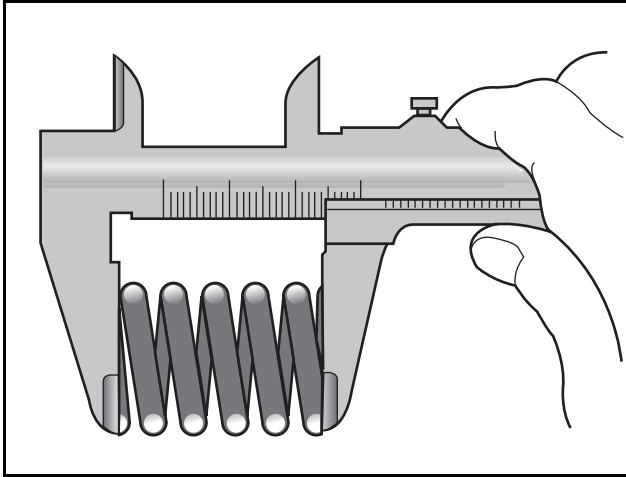

EA3M2033

- 1) Measure the free length of the valve spring with vernier calipers.
- 2) If the measurement is below the specification, replace the valve spring.

Item		Free length
Intake	Inside	59.5 mm (2.3425 in.)
	Outside	57.0 mm (2.2441 in.)
Exhaust	Inside	59.5 mm (2.3425 in.)
	Outside	57.0 mm (2.2441 in.)

3. Check the squareness of the valve spring.

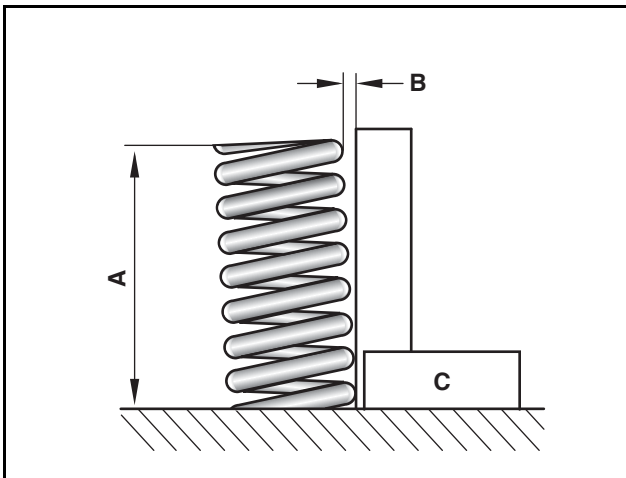

EDL022097A

A. Free length B. Squareness C. Straightedge

- 1) Use a surface plate and straightedge to measure the squareness of the valve spring.

- 2) If the measurement exceeds the allowable limit, replace the valve spring.

Item		Specified value	Allowable limit
Intake	Inside	1.5 mm (0.0591 in.) or less	2.0 mm (0.0787 in.)
	Outside	1.5 mm (0.0591 in.) or less	2.0 mm (0.0787 in.)
Exhaust	Inside	1.5 mm (0.0591 in.) or less	2.0 mm (0.0787 in.)
	Outside	1.5 mm (0.0591 in.) or less	2.0 mm (0.0787 in.)

4. Check the tension of the valve spring.

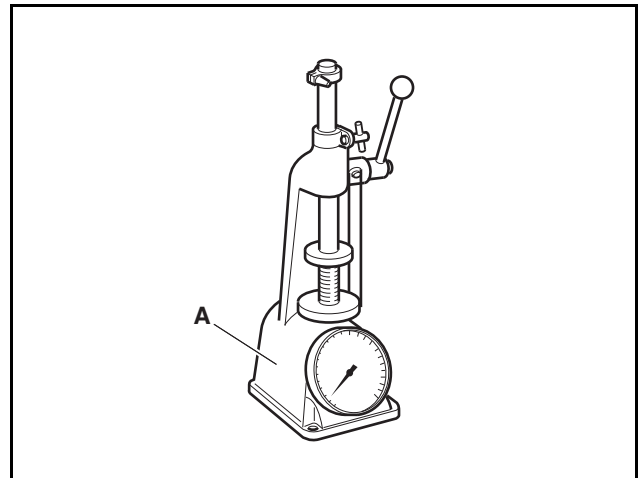

EDL022098B

- 1) Measure the tension of the valve spring with a spring tester (A).
- 2) If the measurement is below the allowable limit, replace the valve spring.

Set length		Spring tension	Allowable limit
Intake	Inside	41.0/28.6 mm (1.6142/1.126 in.)	14.8/25.0 kg (32.6284/55.1156 lb) ±1.5/±2.0 kg (±3.31/±4.41 lb)
	Outside	44.0/31.6 mm (1.7323/1.2441 in.)	25.5/52.3 kg (56.22/115.30 lb) ±2.0/±2.5 kg (±4.41/±4.42 lb)
Exhaust	Inside	41.0/28.6 mm (1.6142/1.126 in.)	14.8/25.0 kg (32.6284/55.1156 lb) ±1.5/±2.0 kg (±3.31/±4.41 lb)
	Outside	44.0/31.6 mm (1.7323/1.2441 in.)	25.5/52.3 kg (56.22/115.30 lb) ±2.0/±2.5 kg (±4.41/±5.51 lb)

# 10. Cylinder Block/Head

## Rocker Arms

### Checking and Measuring the Assemblies

#### 1. Rocker arm bracket (integrated with shaft)

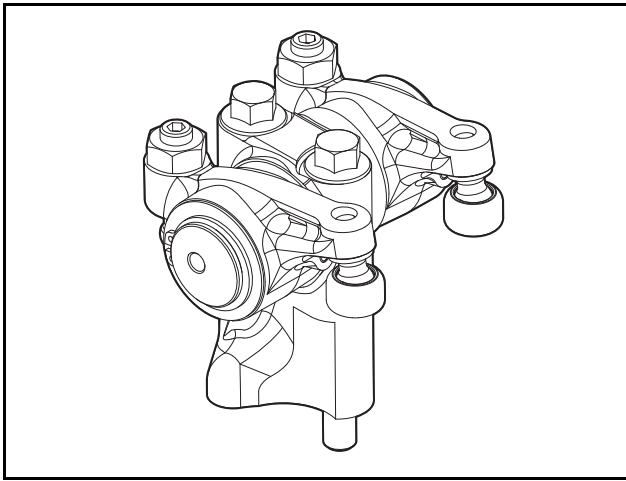

EDX22230179

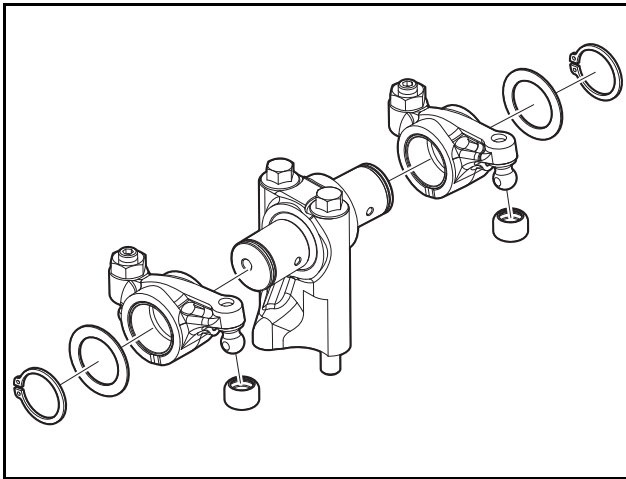

EDX22230180

- 1) Measure the outside diameter of the rocker arm with a micrometer at the point where the rocker arm is assembled; if the measurement exceeds the allowable limit, replace it.

- Rocker arm specifications

Item	Specified value	Allowable limit
Bushing I.D.	Ø27.991 ~ Ø28.012 mm (Ø1.1020 ~ Ø1.1028 in.)	28.137 mm (1.1078 in.)
Shaft O.D.	Ø27.953 ~ Ø27.976 mm (Ø1.1005 ~ Ø1.1014 in.)	27.916 mm (1.099 in.)
Clearance	0.015 ~ 0.059 mm (0.0006 ~ 0.0023 in.)	0.12 mm (0.00472 in.)

#### 2. Rocker arms

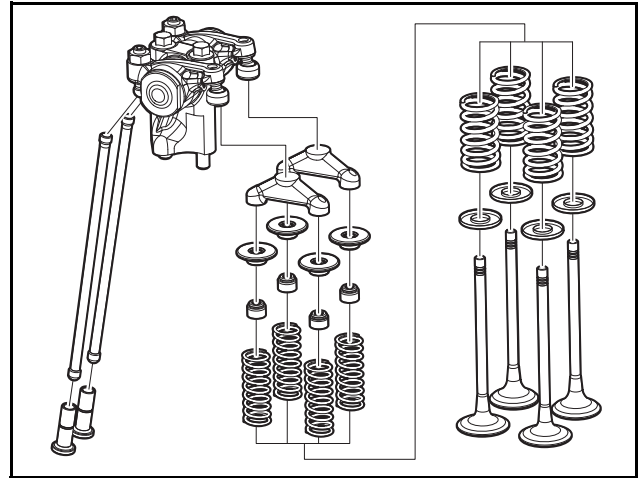

EDX22190049

- 1) Check the surface where the rocker arm is in contact with the valve for scratches or worn pins; if the damage is minor, polish it with an oily grindstone or fine sandpaper. Note) If the damage is severe, replace the part.

### Assembling the Rocker Arms

1. After checking the rocker arm and rocker arm bracket for clogged oil passages, clean the rocker arm thoroughly; then, reassemble the rocker arm in the reverse order of assembly.

## Tappet and Pushrod

### Tappet Clearance

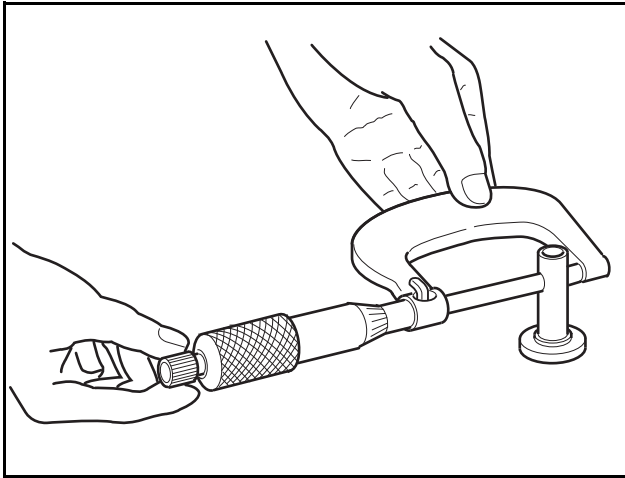

EDM20611

1. Measure the outside diameter of the tappet and the inside diameter of the cylinder block tappet hole. If the measurement exceeds the allowable limit, replace the tappet.
- Clearance between cylinder block and tappet

Reference value	Allowable limit
0.035 ~ 0.077 mm (0.0014 ~ 0.0030 in.)	0.15 mm (0.0059 in.)

### Pushrod Deflection

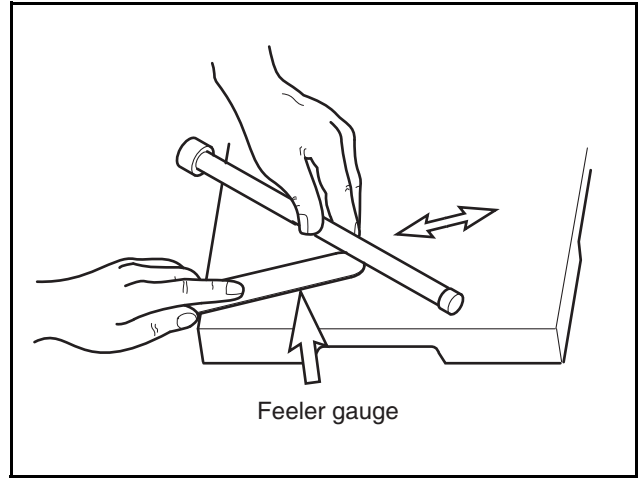

EA0M4073

1. Place the pushrod on a surface plate and measure its deflection with a feeler gauge while rolling it. If the measurement exceeds the allowable limit, replace it with a new one.
- Pushrod deflection

Allowable limit	0.3 mm (0.0118 in.) or less
-----------------	-----------------------------

### Inspecting the Tappet Visually

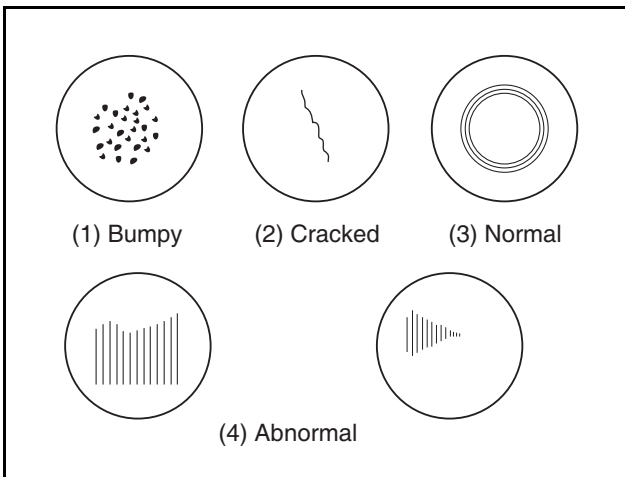

EA0M4070

1. Check the surface of the tappet which slides in contact with the camshaft for scratches, cracks and other damage. For minor damage, use an oily grindstone or fine sandpaper to polish the surface. For severe damage, replace the tappet.

# 10. Cylinder Block/Head

## Camshaft

### Camshaft Play

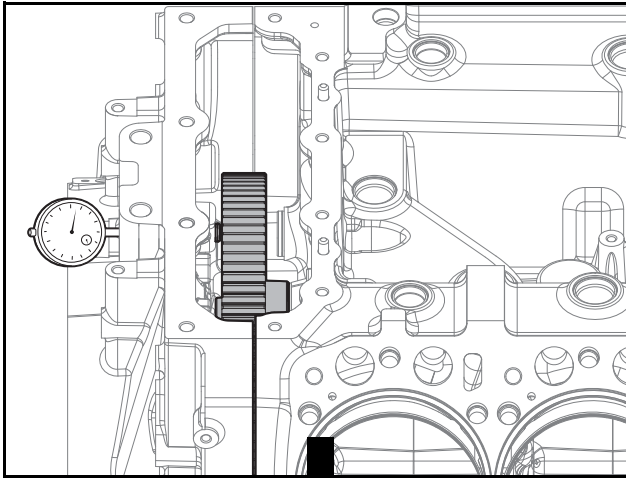

EDX22230185

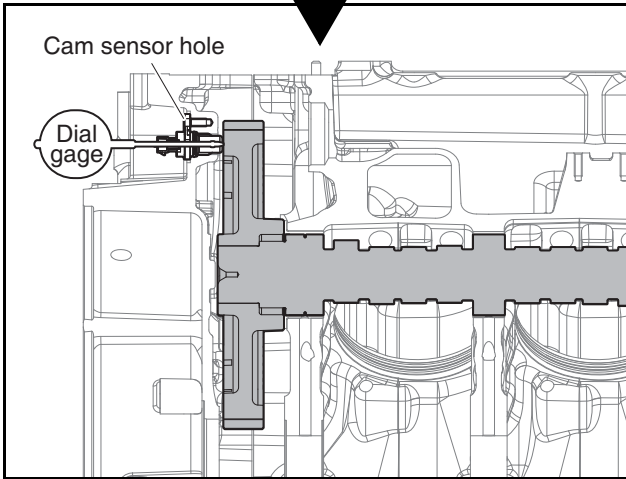

EDX22230186

1. Push the camshaft in the direction of the pulley.
2. Install a dial gauge on the camshaft gear.
3. Use a screwdriver to move the side of the camshaft gear and measure the axial play of the camshaft.

Item	Minimum	Maximum
End play	0.1 mm (0.0039 in.)	0.85 mm (0.0335 in.)

4. If there is too much free play, use a thrust washer with a different thickness to adjust it.

### Checking and Measuring the Camshaft

1. Visual inspection
  - 1) Check the cam surface visually for damage. If any minor defects are found, polish them with an oilstone to correct them. If the damage is severe, replace the part.
2. Cam lobe height

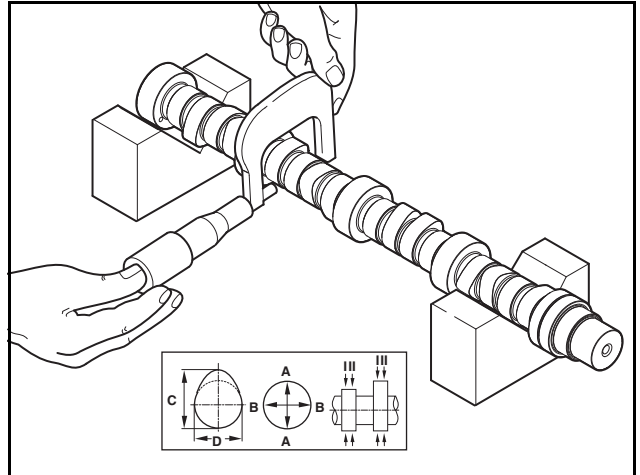

EDX15240095

- 1) Use a micrometer to measure the cam lobe height and journal diameter.
- 2) The camshaft must be replaced if the measured value is lower than the specified limit.

		Reference value	Allowable limit
Cam lobe height (C)	Intake	55.356 mm (2.1794 in.)	55.06 mm (2.1677 in.)
	Exhaust	56.378 mm (2.2196 in.)	56.08 mm (2.2079 in.)
Camshaft journal diameter (A, B)		Ø69.91 ~ Ø69.94 mm (Ø2.7524 ~ Ø2.7535 in.)	69.560 mm (2.7386 in.)

# 10. Cylinder Block/Head

## 3. Cam bearing diameter

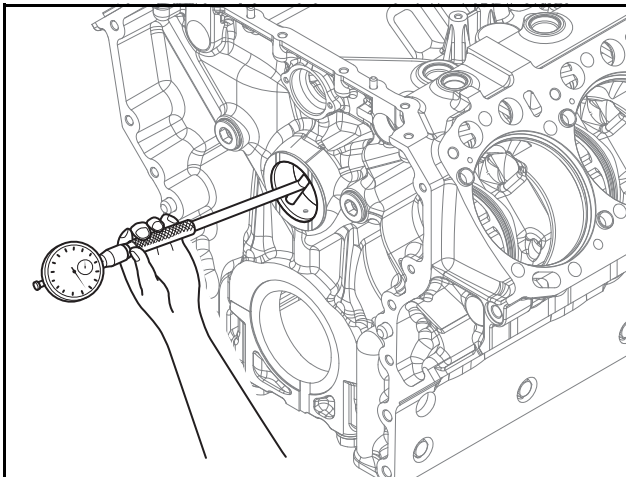

EDX22190051

- 1) Measure the inside diameter of the camshaft bushing with a cylinder gauge; then, compare the inside and outer diameters and replace the part if the measurements deviate from the normal values.

- Camshaft bearing inside diameter

Item	Reference value	Allowable limit
Thrust	Ø70.070 ~ Ø70.090 mm (Ø2.7587 ~ Ø2.7594 in.)	Ø70.19 mm (2.7634 in.)
Middle	Ø70.000 ~ Ø70.030 mm (Ø2.7559 ~ Ø2.7571 in.)	Ø70.19 mm (2.7634 in.)

## 4. Clearance

- 1) Clearance between the camshaft journal and camshaft body

- Clearance between the camshaft journal and bushing

Item	Reference value	Allowable limit
Thrust	0.060 ~ 0.120 mm (0.0024 ~ 0.0047 in.)	0.240 mm (0.0094 in.)
Middle	0.130 ~ 0.180 mm (0.0051 ~ 0.0071 in.)	0.240 mm (0.0094 in.)

## Replacing the Camshaft Bearing

1. Replacing the Camshaft Bearing

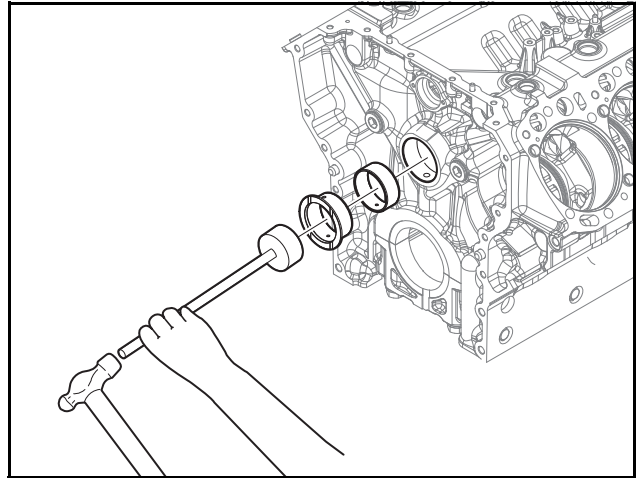

EDX22190052

- 1) Use a disassembly/assembly tool to replace the camshaft bearing.

2. Camshaft runout

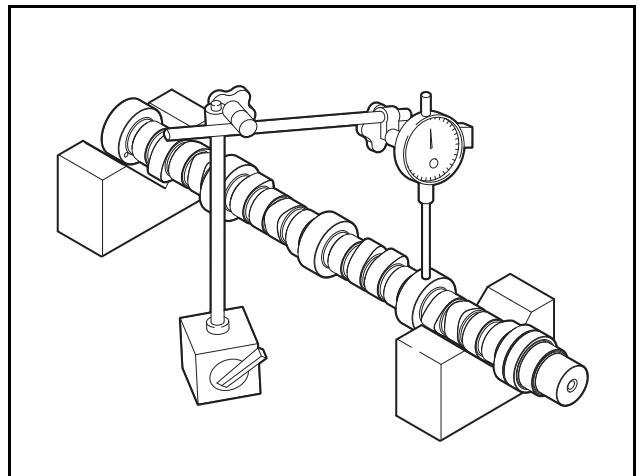

EDX15240096

- 1) Place the camshaft on two V-blocks; then, check and adjust the camshaft runout. If severe, replace the part.

- Camshaft deflection

Reference value	Allowable limit
0.05 mm (0.002 in.)	0.15 mm (0.0059 in.)

## 10. Cylinder Block/Head

---

# 11. Electrical System

Electronic Components .....	149
Electronic Components.....	149
Circuit Diagram .....	151
General Information .....	151
Engine Connectors .....	152
Engine Control Unit (ECU) Engine Connectors .....	156
Switches and Sensors .....	161
Electronic Control Unit .....	161
Boost Pressure and Temperature Sensor .....	168
Engine Oil Pressure and Temperature Sensor .....	168
Coolant Temperature Sensor.....	168
Ambient Temperature Sensor.....	168
Common Rail Pressure Sensor .....	168
Crankshaft Speed Sensor.....	168
Camshaft Speed Sensor.....	168
Engine Control Unit (ECU) .....	169
Engine Control Unit (ECU) Connectors .....	169
Engine Control Unit (ECU) Input/Output.....	170
Engine Control Unit (ECU) Operating Conditions .....	171
TMS 3.0 (Option) .....	172
Outside Drawing .....	172
Front PIN Map.....	173
TMS 3.0 TYPE A (LTE) Module (EG25-G) Specification.....	174
Schematic diagram .....	175
Starter Motor .....	177
General Information .....	177
Circuit Diagram .....	178
Alternator .....	179
General Information .....	179
Circuit Diagram .....	180



## Electronic Components

### Electronic Components

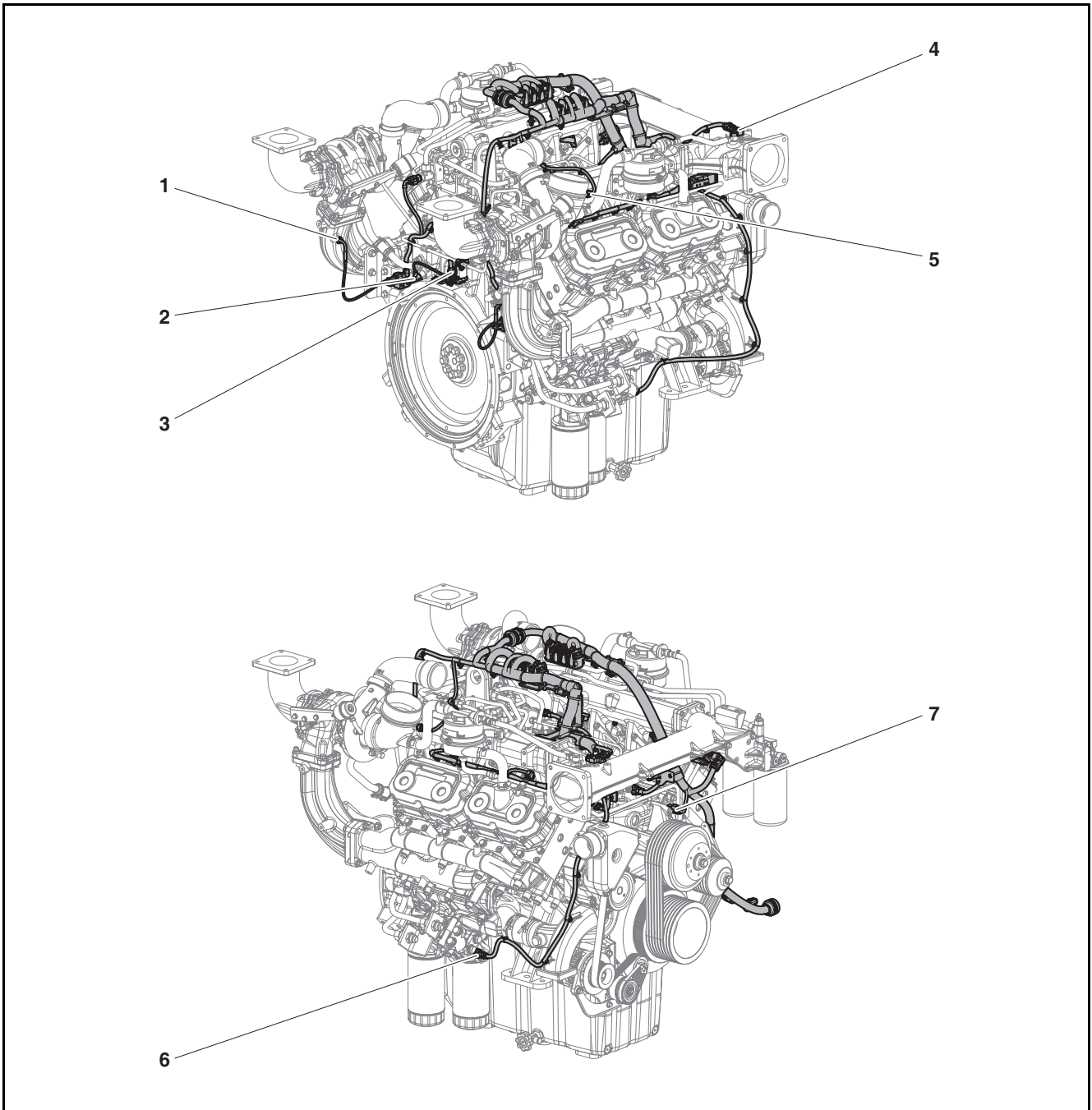

EDX15240004

- |                             |                         |                         |
|-----------------------------|-------------------------|-------------------------|
| 1. Exhaust gas temp. sensor | 4. TMAP sensor          | 7. Coolant temp. sensor |
| 2. Crank sensor             | 5. Ambient temp. sensor |                         |
| 3. CAM sensor               | 6. Oil pressure sensor  |                         |

## 11. Electrical System

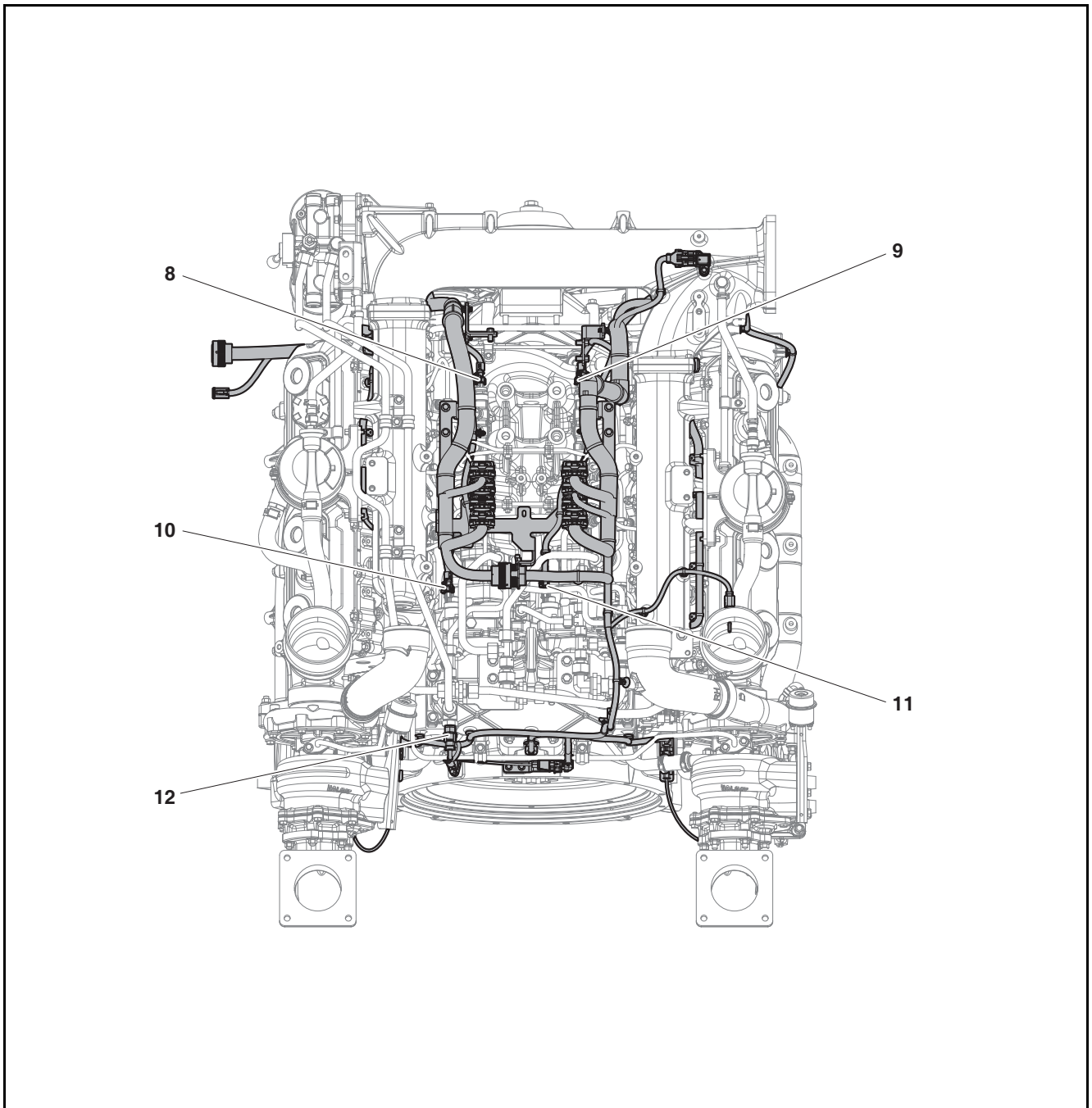

EDX15240005

- |                            |                           |                       |
|----------------------------|---------------------------|-----------------------|
| 8. Rail pressure sensor #1 | 10. Fuel metering unit #1 | 12. Fuel temp. sensor |
| 9. Rail pressure sensor #2 | 11. Fuel metering unit #2 |                       |

## Circuit Diagram

### General Information

1. This section provides information on the engine wire harnesses and the circuit number of connectors.

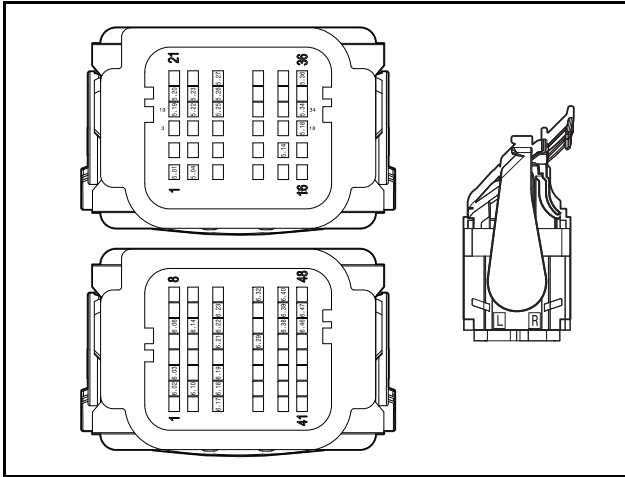

EDL08190028

2. The wire colors are as follows.
  - 1) B : Black
  - 2) Brn : Brown
  - 3) Gra : Gray
  - 4) L : Blue
  - 5) O : Orange
  - 6) W : White
  - 7) Y : Yellow
  - 8) R : Red
  - 9) RG : Red Green
  - 10) RV : Red Violet
  - 11) LW : Blue White
  - 12) GrL : Gray Blue
  - 13) GGr : Green Gray
3. The ECU pin no. refers to the pin number of each engine connector.
4. The sensor pin no. refers to the pin number of each sensor connector.

# 11. Electrical System

## Engine Connectors

"For the function of the ECU, the vehicle configuration according to the terminal diagram is mandatory"

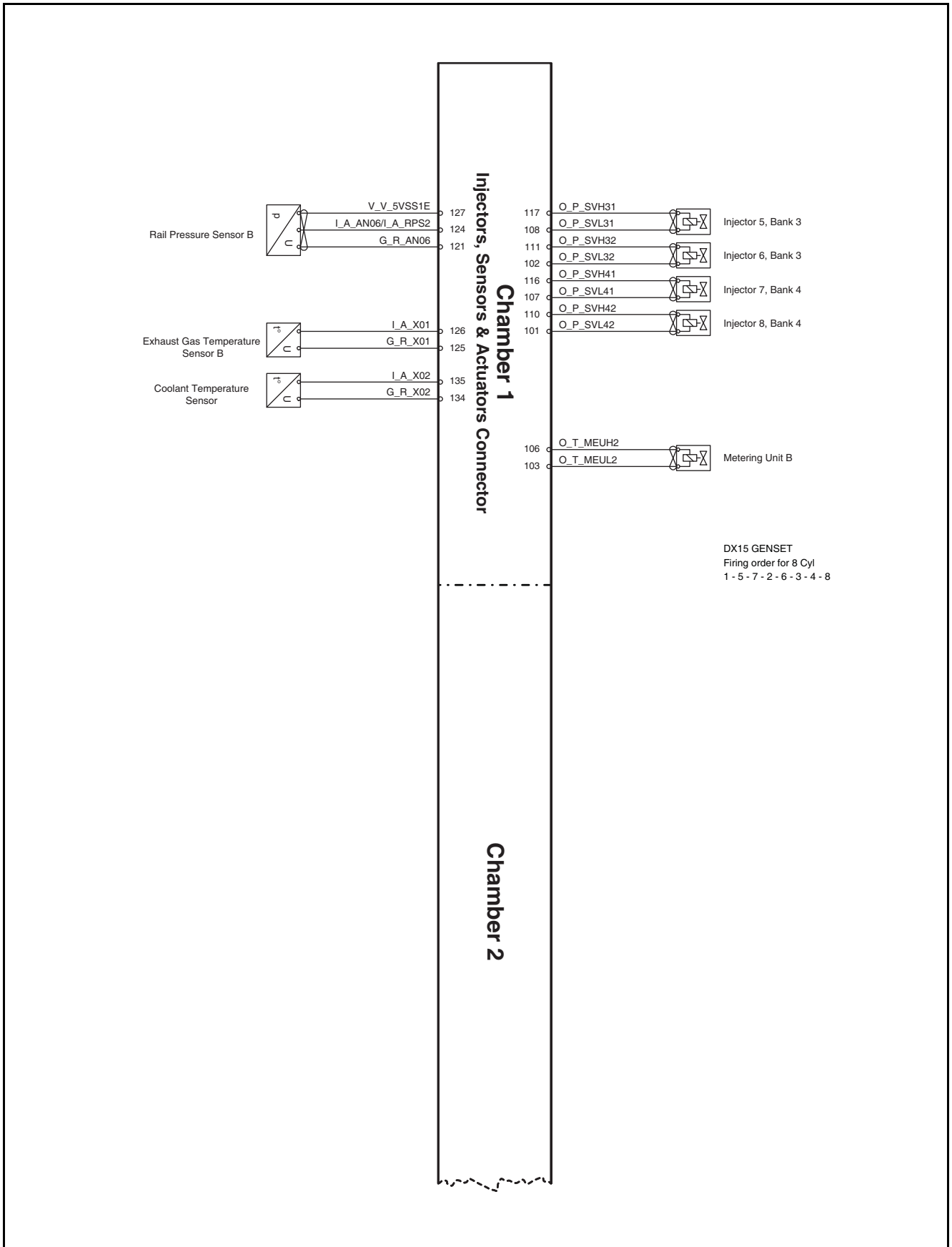

EDX15240006

"For the function of the ECU, the vehicle configuration according to the terminal diagram is mandatory"

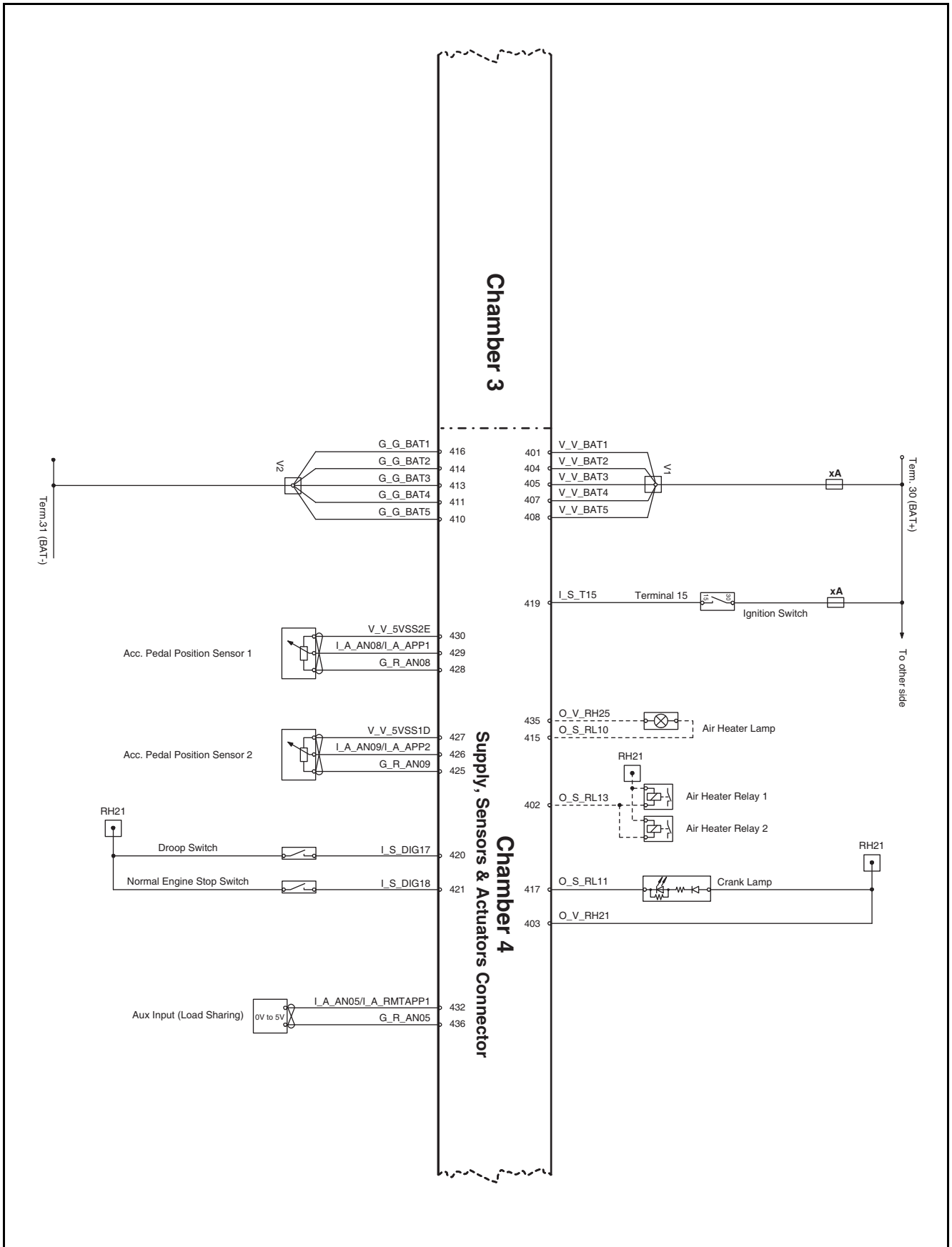

EDX15240007

# 11. Electrical System

"For the function of the ECU, the vehicle configuration according to the terminal diagram is mandatory"

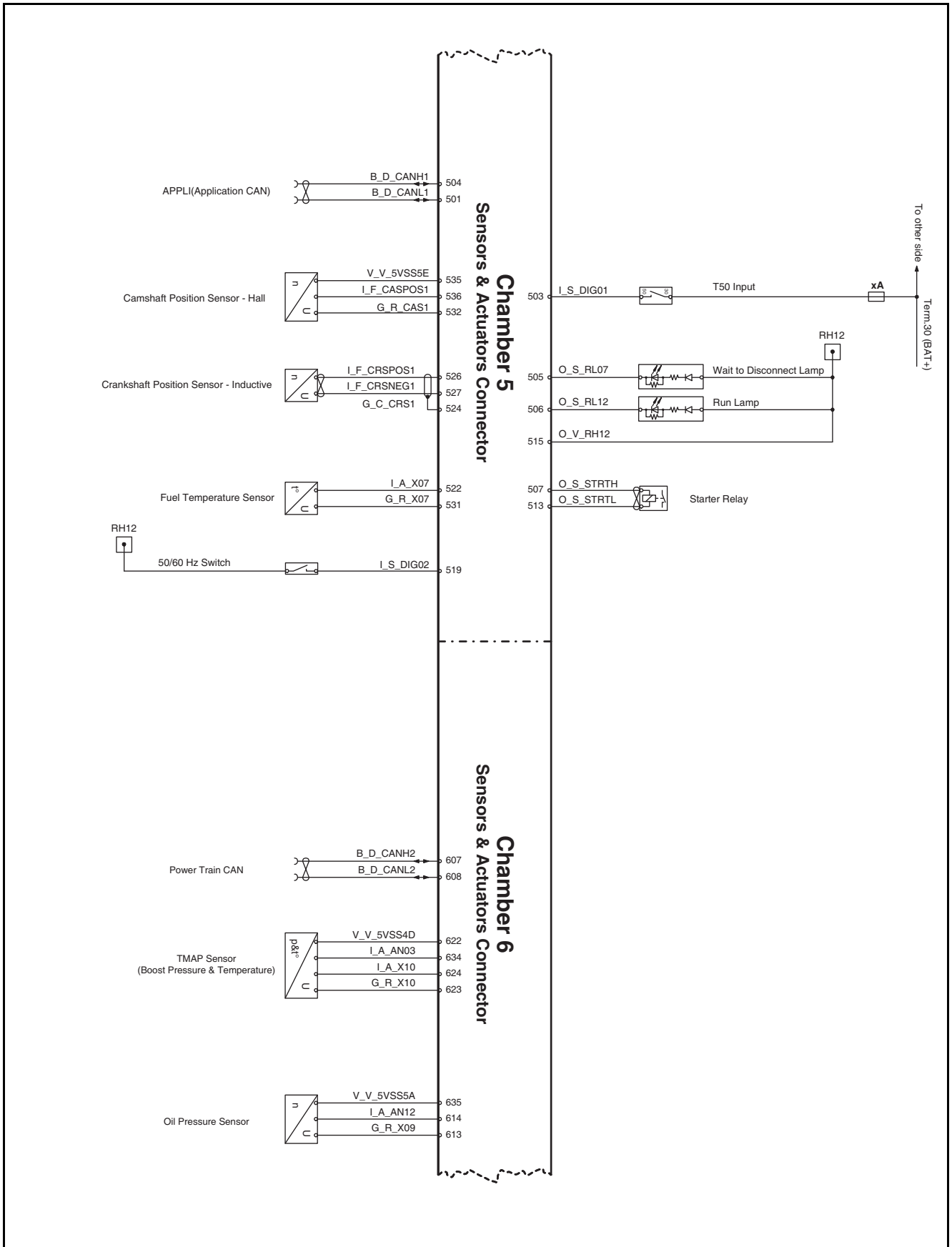

EDX15240008

# 11. Electrical System

"For the function of the ECU, the vehicle configuration according to the terminal diagram is mandatory"

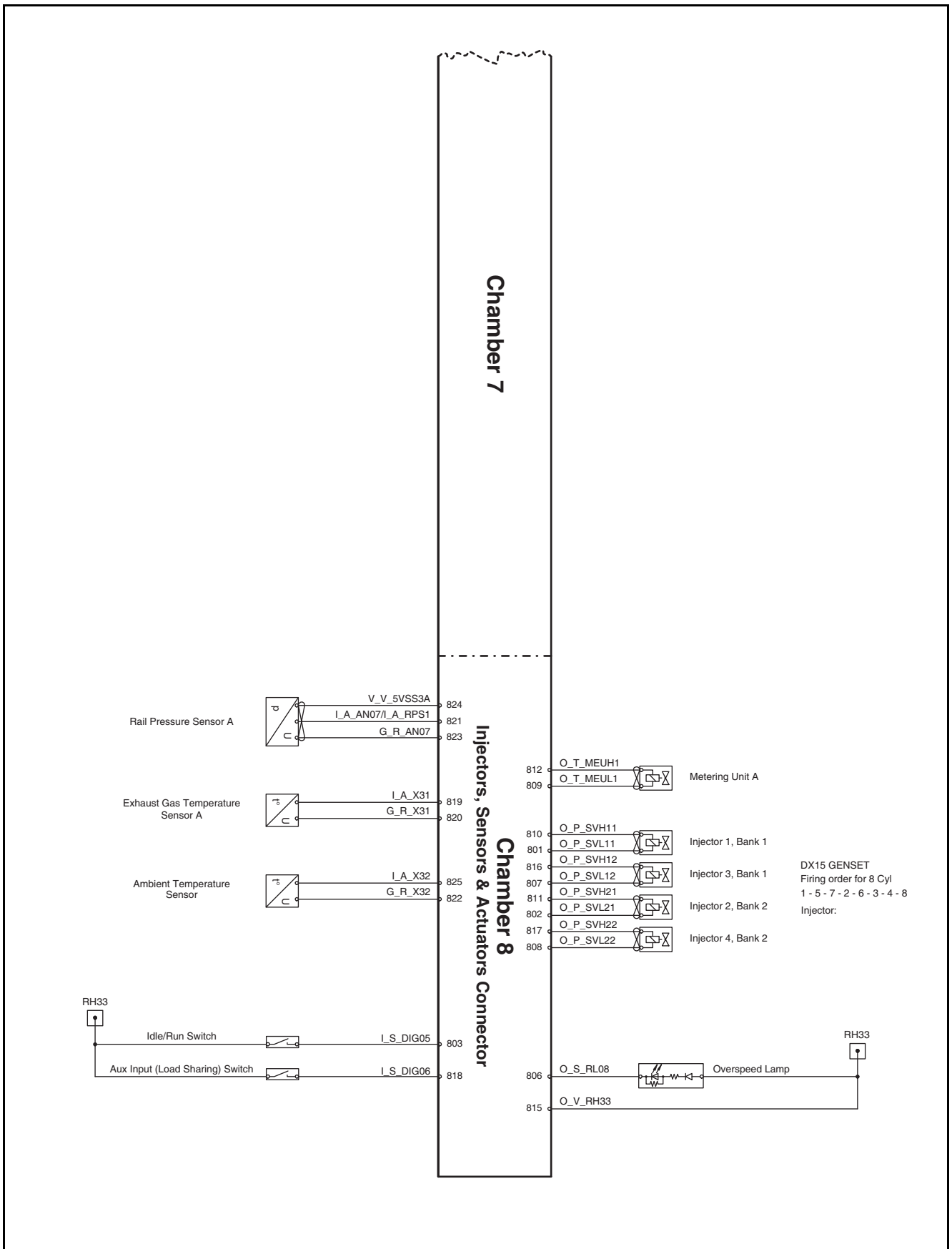

EDX15240009

# 11. Electrical System

## Engine Control Unit (ECU) Engine Connectors

### ECU Connector RH

No.	Wire label	Size (mm <sup>2</sup> )	Color	Circuit Description	From	No.	To	No.	Remark
1	126	0.75	Y	EGT sensor LH signal	EGT sensor LH (EGTL)	2	Inter conn 2 (INT 2)	2	
2	125	0.75	B	EGT sensor LH GND	EGT sensor LH (EGTL)	1	Inter conn 2 (INT 2)	1	
3	403	1.50	R	Air heater relay high	Inter conn 2 (INT 2)	20	S403	-	Splice 403
4	402	1.50	Brn	Air heater relay low	Inter conn 2 (INT 2)	21	S402	-	Splice 402
5	403A	1.50	R	Air heater relay high	S403	-	Air heater relay 1 (HEAT 1)	1	Splice 403
6	402A	1.50	Brn	Air heater relay low	S402	-	Air heater relay 1 (HEAT 1)	2	Splice 402
7	403B	1.50	R	Air heater relay high	S403	-	Air heater relay 2 (HEAT 2)	1	Splice 403
8	402B	1.50	Brn	Air heater relay low	S402	-	Air heater relay 2 (HEAT 2)	2	Splice 402
9	501	1.50	Y	Can1 low	ECU 5 (5)	1	Inter conn 2 (INT 2)	6	
10	504	1.50	G	Can1 high	ECU 5 (5)	4	Inter conn 2 (INT 2)	7	
11	535	0.75	R	Cam shaft sensor PWR	ECU 5 (5)	35	Cam shaft sensor (CAM)	3	
12	536	0.75	W	Cam shaft sensor POS	ECU 5 (5)	36	Cam shaft sensor (CAM)	2	
13	532	0.75	B	Cam shaft sensor GND	ECU 5 (5)	32	Cam shaft sensor (CAM)	1	
14	527	0.75	P	Crank shaft sensor NEG	ECU 5 (5)	27	Crank shaft sensor (CRS)	1	
15	526	0.75	O	Crank shaft sensor POS	ECU 5 (5)	26	Crank shaft sensor (CRS)	2	
16	524	0.75	B	Crank shaft sensor GND	ECU 5 (5)	24	Crank shaft sensor (CRS)	3	Shield drain (526/527)
17	507	1.50	GrL	Starter relay high	ECU 5 (5)	7	Inter conn 2 (INT 2)	4	
18	513	1.50	GGr	Starter relay low	ECU 5 (5)	13	Inter conn 2 (INT 2)	5	
19	522	0.75	W	Fuel temp sensor signal	ECU 5 (5)	22	Fuel temp sensor (FTS)	1	
20	531	0.75	B	Fuel temp sensor GND	ECU 5 (5)	31	Fuel temp sensor (FTS)	2	
21	506	1.50	G	Run lamp	ECU 5 (5)	6	Inter conn 2 (INT 2)	12	
22	505	1.50	Y	Wait to disconnect lamp	ECU 5 (5)	5	Inter conn 2 (INT 2)	13	
23	519	0.75	W	50/60 Hz switch	ECU 5 (5)	19	Inter conn 2 (INT 2)	17	
24	503	1.50	G	TSO input	ECU 5 (5)	3	Inter conn 2 (INT 2)	3	
25	607	0.75	W	Can2 high	ECU 6 (6)	7	Inter conn 2 (INT 2)	8	
26	608	0.75	Y	Can2 low	ECU 6 (6)	8	Inter conn 2 (INT 2)	9	
27	635	0.75	R	Oil press sensor PWR	ECU 6 (6)	35	Oil press sensor (OPS)	3	
28	613	0.75	B	Oil press sensor GND	ECU 6 (6)	13	Oil press sensor (OPS)	2	
29	614	0.75	Brn	Oil press sensor signal	ECU 6 (6)	14	Oil press sensor (OPS)	1	
30	634	0.75	W	TMAP press sensor signal	ECU 6 (6)	34	TMAP sensor (TMAP)	1	
31	622	0.75	R	TMAP press temp sensor PWR	ECU 6 (6)	22	TMAP sensor (TMAP)	2	

## 11. Electrical System

No.	Wire label	Size (mm <sup>2</sup> )	Color	Circuit Description	From	No.	To	No.	Remark
32	624	o.	O	TMAP temp sensor signal	ECU 6 (6)	24	TMAP sensor (TMAP)	3	
33	623	0.75	B	TMAP press temp sensor GND	ECU 6 (6)	23	TMAP sensor (TMAP)	4	
34	812	1.50	G	Fuel metering unit RH high	ECU 8 (8)	12	Fuel metering unit RH (FMUR)	1	
35	809	1.50	L	Fuel metering unit RH low	ECU 8 (8)	9	Fuel metering unit RH (FMUR)	2	
36	825	0.75	Y	Intake air temp sensor signal	ECU 8 (8)	25	Ambient temp sensor (ATS)	1	
37	822	0.75	B	Intake air temp sensor GND	ECU 8 (8)	22	Ambient temp sensor (ATS)	2	
38	824	0.75	R	Rail press sensor RH PWR	ECU 8 (8)	24	Rail press sensor RH (RPSR)	3	
39	821	0.75	W	Rail press sensor RH signal	ECU 8 (8)	21	Rail press sensor RH (RPSR)	2	
40	823	0.75	B	Rail press sensor RH GND	ECU 8 (8)	23	Rail press sensor RH (RPSR)	1	
41	810	1.50	G	Injector 1 "High"	ECU 8 (8)	10	Injector inline RH (INJR)	1	
42	801	1.50	Y	Injector 1 "Low"	ECU 8 (8)	1	Injector inline RH (INJR)	2	
43	811	1.50	LW	Injector 2 "High"	ECU 8 (8)	11	Injector inline RH (INJR)	3	
44	802	1.50	GrL	Injector 2 "Low"	ECU 8 (8)	2	Injector inline RH (INJR)	4	
45	816	1.50	G	Injector 3 "High"	ECU 8 (8)	16	Injector inline RH (INJR)	5	
46	807	1.50	Y	Injector 3 "Low"	ECU 8 (8)	7	Injector inline RH (INJR)	6	
47	817	1.50	LW	Injector 4 "High"	ECU 8 (8)	17	Injector inline RH (INJR)	7	
48	808	1.50	GrL	Injector 4 "Low"	ECU 8 (8)	8	Injector inline RH (INJR)	8	
49	819	0.75	Y	EGT sensor RH signal	ECU 8 (8)	19	EGT sensor RH (EGTR)	2	
50	820	0.75	B	EGT sensor RH GND	ECU 8 (8)	20	EGT sensor RH (EGTR)	1	
51	803	1.50	G	Idle/Run switch	ECU 8 (8)	3	Inter conn 2 (INT 2)	16	
52	818	1.50	Y	AUX input switch	ECU 8 (8)	18	Inter conn 2 (INT 2)	15	
53	806	1.50	LW	Over speed lamp	ECU 8 (8)	6	Inter conn 2 (INT 2)	14	
54	515	1.50	RG	Switch battery output RH12	ECU 5 (5)	15	Inter conn 2 (INT 2)	18	
55	815	1.50	RV	Switch battery output RH33	ECU 8 (8)	15	Inter conn 2 (INT 2)	19	

# 11. Electrical System

## ECU Connector LH

No.	Wire label	Size (mm <sup>2</sup> )	Color	Circuit Description	From	No.	To	No.	Remark
1	127	0.75	R	Rail pressure sensor LH PWR	ECU 1 (1)	27	Rail pressure sensor LH (RPSL)	3	
2	124	0.75	W	Rail pressure sensor LH signal	ECU 1 (1)	24	Rail pressure sensor LH (RPSL)	2	
3	121	0.75	B	Rail pressure sensor LH GND	ECU 1 (1)	21	Rail pressure sensor LH (RPSL)	1	
4	117	1.50	G	Injector 5 "High"	ECU 1 (1)	17	Injector inline LH (INJL)	1	
5	108	1.50	Y	Injector 5 "Low"	ECU 1 (1)	8	Injector inline LH (INJL)	2	
6	111	1.50	LW	Injector 6 "High"	ECU 1 (1)	11	Injector inline LH (INJL)	3	
7	102	1.50	GrL	Injector 6 "Low"	ECU 1 (1)	2	Injector inline LH (INJL)	4	
8	116	1.50	G	Injector 7 "High"	ECU 1 (1)	16	Injector inline LH (INJL)	5	
9	107	1.50	Y	Injector 7 "Low"	ECU 1 (1)	7	Injector inline LH (INJL)	6	
10	110	1.50	LW	Injector 8 "High"	ECU 1 (1)	10	Injector inline LH (INJL)	7	
11	101	1.50	GrL	Injector 8 "Low"	ECU 1 (1)	1	Injector inline LH (INJL)	8	
12	106	1.50	G	Fuel metering unit LH high	ECU 1 (1)	6	Fuel metering unit LH (FMUL)	1	
13	103	1.50	L	Fuel metering unit LH low	ECU 1 (1)	3	Fuel metering unit LH (FMUL)	2	
14	135	0.75	Brn	Coolant temperature sensor signal	ECU 1 (1)	35	Coolant temperature sensor (CTS)	1	
15	134	0.75	B	Coolant temperature sensor GND	ECU 1 (1)	34	Coolant temperature sensor (CTS)	2	
16	126	0.75	Y	EGT sensor LH signal	ECU 1 (1)	26	Inter conn 2 (INT 2)	2	
17	125	0,75	B	EGT sensor LH GND	ECU 1 (1)	25	Inter conn 2 (INT 2)	1	
18	403	1.50	R	Air heater relay high	ECU 4 (4)	3	SP_12	-	Splice 403
19	402	1.50	Brn	Air heater relay low	ECU 4 (4)	2	Inter conn 2 (INT 2)	21	
20	416	1.50	B	Battery ground 1	ECU 4 (4)	16	SP_01	-	Splice 416
21	416A	1.50	B	Battery ground 1	SP_01	-	Inter conn 1 (INT 1)	1	Splice 416
22	414	1.50	B	Battery ground 2	ECU 4 (4)	14	SP_02	-	Splice 414
23	414A	1.50	B	Battery ground 2	SP_02	-	Inter conn 1 (INT 1)	2	Splice 414
24	413	1.50	B	Battery ground 3	ECU 4 (4)	13	SP_02	-	Splice 414
25	411	1.50	B	Battery ground 4	ECU 4 (4)	11	SP_03	-	Splice 411
26	411A	1.50	B	Battery ground 4	SP_03	-	Inter conn 1 (INT 1)	3	Splice 411
27	410	1.50	B	Battery ground 5	ECU 4 (4)	10	SP_03	-	Splice 411
28	401	1.50	R	Battery plus 1	ECU 4 (4)	1	SP_04	-	Splice 401
29	401A	1.50	R	Battery plus 1	SP_04	-	Inter conn 1 (INT 1)	9	Splice 401
30	404	1.50	R	Battery plus 2	ECU 4 (4)	4	SP_05	-	Splice 404
31	404A	1.50	R	Battery plus 2	SP_05	-	Inter conn 1 (INT 1)	10	Splice 404
32	405	1.50	R	Battery plus 3	ECU 4 (4)	5	SP_05	-	Splice 404
33	407	1.50	R	Battery plus 4	ECU 4 (4)	7	SP_06	-	Splice 407

## 11. Electrical System

No.	Wire label	Size (mm <sup>2</sup> )	Color	Circuit Description	From	No.	To	No.	Remark
34	407A	1.50	R	Battery plus 4	SP_06	-	Inter conn 1 (INT 1)	11	Splice 407
35	408	1.50	R	Battery plus 5	ECU 4 (4)	8	SP_06	-	Splice 407
36	421	0.75	Y	Emergency stop switch	ECU 4 (4)	21	Inter conn 1 (INT 1)	4	
37	419	0,75	G	Key on (T15)	ECU 4 (4)	19	SP_07	-	Splice 419
38	419A	0.75	G	Key on (T15)	SP_07	-	Inter conn 1 (INT 1)	12	Splice 419
39	425	0.75	B	ACC.pedal position sensor 2 GND	ECU 4 (4)	25	Inter conn 1 (INT 1)	13	
40	426	0.75	W	ACC.pedal position sensor 2 SIG	ECU 4 (4)	26	Inter conn 1 (INT 1)	14	
41	427	0.75	O	ACC.pedal position sensor 2 PWR	ECU 4 (4)	27	Inter conn 1 (INT 1)	15	
42	428	0.75	B	ACC.pedal position sensor 1 GND	ECU 4 (4)	28	Inter conn 1 (INT 1)	16	
43	429	0.75	Y	ACC.pedal position sensor 1 SIG	ECU 4 (4)	29	Inter conn 1 (INT 1)	17	
44	430	0.75	R	ACC.pedal position sensor 1 PWR	ECU 4 (4)	30	Inter conn 1 (INT 1)	18	
45	432	0.75	W	AUX input SIG	ECU 4 (4)	32	Inter conn 1 (INT 1)	27	
46	436	0.75	B	AUX input GND	ECU 4 (4)	36	Inter conn 1 (INT 1)	28	
47	420	0.75	W	Droop switch	ECU 4 (4)	20	Inter conn 1 (INT 1)	5	
48	417	1.50	G	Crank lamp	ECU 4 (4)	17	Inter conn 1 (INT 1)	20	
49	501	1.50	Y	Can1 low	SP_08	-	Inter conn 2 (INT 2)	6	Splice 501
50	504	1.50	G	Can1 high	SP_09	-	Inter conn 2 (INT 2)	7	Splice 504
51	501A	1.50	Y	Can1 low	SP_08	-	Inter conn 1 (INT 1)	23	Splice 501
52	504A	1.50	G	Can1 high	SP_09	-	Inter conn 1 (INT 1)	24	Splice 504
53	507	1.50	GrL	Starter relay high	Inter conn 2 (INT 2)	4	Inter conn 1 (INT 1)	21	
54	513	1.50	GGr	Starter relay low	Inter conn 2 (INT 2)	5	Inter conn 1 (INT 1)	22	
55	506	1.50	G	Run lamp	Inter conn 2 (INT 2)	12	Inter conn 1 (INT 1)	29	
56	505	1.50	Y	Wait to disconnect lamp	Inter conn 2 (INT 2)	13	Inter conn 1 (INT 1)	30	
57	519	0.75	W	50/60 Hz switch	Inter conn 1 (INT 1)	6	Inter conn 2 (INT 2)	17	
58	503	1.50	G	T50 input	Inter conn 1 (INT 1)	19	Inter conn 2 (INT 2)	3	
59	607	0.75	W	Can2 high	SP_10	-	Inter conn 2 (INT 2)	8	Splice 607
60	608	0.75	Y	Can2 low	SP_11	-	Inter conn 2 (INT 2)	9	Splice 608
61	607A	0.75	W	Can2 high	SP_10	-	Inter conn 1 (INT 1)	25	Splice 607
62	608A	0.75	Y	Can2 low	SP_11	-	Inter conn 1 (INT 1)	26	Splice 608

## 11. Electrical System



No.	Wire label	Size (mm <sup>2</sup> )	Color	Circuit Description	From	No.	To	No.	Remark
63	803	1.50	G	Idle/Run switch	Inter conn 1 (INT 1)	7	Inter conn 2 (INT 2)	16	
64	818	1.50	Y	AUX input switch	Inter conn 1 (INT 1)	8	Inter conn 2 (INT 2)	15	
65	806	1.50	LW	Over speed lamp	Inter conn 1 (INT 1)	31	Inter conn 2 (INT 2)	14	
66	501B	0.75	y	Can1 low	SP_08	-	Check conn (CHECK)	1	Splice 501
67	504B	0.75	G	Can1 high	SP_09	-	Check conn (CHECK)	2	Splice 504
68	416B	0.75	B	Battery ground 1	SP_01	-	Check conn (CHECK)	3	Splice 416
69	401B	0.75	R	Battery plus 1	SP_04	-	Check conn (CHECK)	4	Splice 401
70	419B	0.75	G	Key on (T15)	SP_07	-	Check conn (CHECK)	6	Splice 419
71	607B	0.75	W	Can2 high	SP_10	-	Check conn (CHECK)	8	Splice 607
72	608B	0.75	Y	Can2 low	SP_11	-	Check conn (CHECK)	7	Splice 608
73	515	1.50	RG	Switch battery output RH12	Inter conn 2 (INT 2)	18	Inter conn 3 (INT 3)	1	
74	815	1.50	RV	Switch battery output RH33	Inter conn 2 (INT 2)	19	Inter conn 3 (INT 3)	2	
75	403A	1.50	R	Air heater relay high/switch battery output RH21	SP_12	-	Inter conn 2 (INT 2)	20	Splice 403
76	403B	1.50	R	Switch battery output RH21	SP_12	-	Inter conn 3 (INT 3)	3	Splice 403
77	435	0,75	R	Air heater lamp high	ECU 4 (4)	35	Inter conn 3 (INT 3)	4	
78	415	1.50	w	Air heater lamp low	ECU 4 (4)	15	Inter conn 3 (INT 3)	5	

## Switches and Sensors

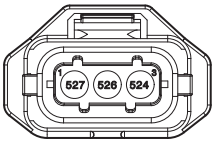
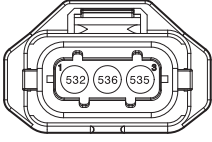
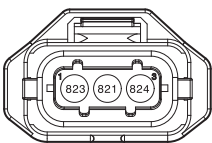
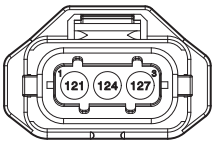
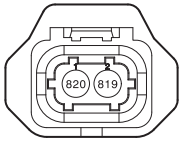
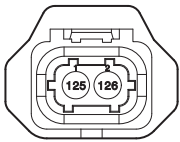

### Electronic Control Unit

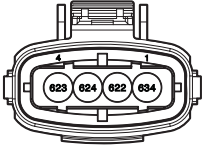
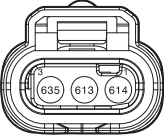
Figure	Circuit	Wire size	Color	Insulation	Circuit description	From	Pin	Connector Pin
Crank shaft sensor (CRS) 	527	0.75	P	FLR91X-A BS01	Crank shaft sensor NEG	ECU 5 (5)	27	1
	526	0.75	O	FLR91X-A BS01	Crank shaft sensor POS	ECU 5 (5)	26	2
	524	0.75	B	FLR91X-A	Crank shaft sensor GND	ECU 5 (5)	24	3
Cam shaft sensor (CAM) 	532	0.75	B	FLR91X-A	Cam shaft sensor GND	ECU 5 (5)	32	1
	536	0.75	W	FLR91X-A	Cam shaft sensor POS	ECU 5 (5)	36	2
	535	0.75	R	FLR91X-A	Cam shaft sensor PWR	ECU 5 (5)	35	3
Rail press sensor RH (RPSR) 	823	0.75	B	FLR91X-A T05	Rail press sensor RH GND	ECU 8 (8)	23	1
	821	0.75	W	FLR91X-A T05	Rail press sensor RH signal	ECU 8 (8)	21	2
	824	0.75	R	FLR91X-A T05	Rail press sensor RH PWR	ECU 8 (8)	24	3
Rail press sensor LH (RPSL) 	127	0.75	R	FLR91X-A_T01	Rail press sensor LH PWR	ECU 1 (1)	27	3
	124	0.75	W	FLR91X-A_T01	Rail press sensor LH signal	ECU 1 (1)	24	2
	121	0.75	B	FLR91X-A_T01	Rail press sensor LH GND	ECU 1 (1)	21	1
EGT sensor RH (EGTR) 	820	0.75	B	FLR91X-A	EGT sensor RH GND	ECU 8 (8)	20	1
	819	0.75	Y	FLR91X-A	EGT sensor RH signal	ECU 8 (8)	19	2
EGT sensor LH (EGTL) 	125	0.75	B	FLR91X-A	EGT sensor LH GND	EGT sensor LH (EGTL)	1	1
	126	0.75	Y	FLR91X-A	EGT sensor LH signal	EGT sensor LH (EGTL)	2	2

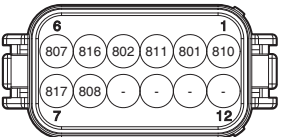
# 11. Electrical System

Figure	Circuit	Wire size	Color	Insulation	Circuit description	From	Pin	Connector Pin
Ambient temp sensor (ATS) 	825	0.75	Y	FLR91X-A	Intake air temp sensor signal	ECU 8 (8)	25	1
	822	0.75	B	FLR91X-A	Intake air temp sensor GND	ECU 8 (8)	22	2
TMAP sensor (TMAP) 	634	0.75	W	FLR91X-A	TMAP press sensor signal	ECU 6 (6)	34	1
	622	0.75	R	FLR91X-A	TMAP press sensor PWR	ECU 6 (6)	22	2
	624	0.75	O	FLR91X-A	TMAP press sensor signal	ECU 6 (6)	24	3
	623	0.75	B	FLR91X-A	TMAP press sensor GND	ECU 6 (6)	23	4
Oil press sensor (OPS) 	614	0.75	Brn	FLR91X-A	Oil press sensor signal	ECU 6 (6)	14	1
	613	0.75	B	FLR91X-A	Oil press sensor GND	ECU 6 (6)	13	2
	635	0.75	R	FLR91X-A	Oil press sensor PWR	ECU 6 (6)	35	3
Fuel metering unit RH (FMUR) 	812	1.5	G	FLR91X-A T04	Fuel metering unit RH high	ECU 8 (8)	12	1
	809	1.5	L	FLR91X-A T04	Fuel metering unit RH low	ECU 8 (8)	9	2
Fuel metering unit LH (FMUL) 	106	1.5	G	FLR91X-A T04	Fuel metering unit LH high	ECU 1 (1)	6	1
	103	1.5	L	FLR91X-A T04	Fuel metering unit LH low	ECU 1 (1)	3	2
Injector inline RH (INJR) 	810	1.5	G	FLR91X-A T06	Injector 1 "High"	ECU 8 (8)	10	1
	801	1.5	Y	FLR91X-A T06	Injector 1 "Low"	ECU 8 (8)	1	2
	811	1.5	LW	FLR91X-A T07	Injector 2 "High"	ECU 8 (8)	11	3
	802	1.5	GrL	FLR91X-A T07	Injector 2 "Low"	ECU 8 (8)	2	4
	816	1.5	G	FLR91X-A T08	Injector 3 "High"	ECU 8 (8)	16	5
	807	1.5	Y	FLR91X-A T08	Injector 3 "Low"	ECU 8 (8)	7	6
	817	1.5	LW	FLR91X-A T09	Injector 4 "High"	ECU 8 (8)	17	7
	808	1.5	GrL	FLR91X-A T09	Injector 4 "Low"	ECU 8 (8)	8	8

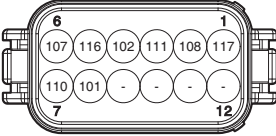
## 11. Electrical System

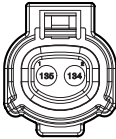
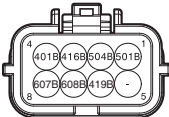
Figure	Circuit	Wire size	Color	Insulation	Circuit description	From	Pin	Connector Pin
<b>Injector inline LH (INJL)</b> 	117	1.5	G	FLR91X-A T02	Injector 5 "High"	ECU 1 (1)	17	1
	108	1.5	Y	FLR91X-A T02	Injector 5 "Low"	ECU 1 (1)	8	2
	111	1.5	LW	FLR91X-A T03	Injector 6 "High"	ECU 1 (1)	111	3
	102	1.5	GrL	FLR91X-A T03	Injector 6 "Low"	ECU 1 (1)	2	4
	116	1.5	G	FLR91X-A T04	Injector 7 "High"	ECU 1 (1)	16	5
	107	1.5	Y	FLR91X-A T04	Injector 7 "Low"	ECU 1 (1)	7	6
	110	1.5	LW	FLR91X-A T05	Injector 8 "High "	ECU 1 (1)	10	7
	101	1.5	GrL	FLR91X-A T05	Injector 8 "Low"	ECU 1 (1)	1	8
<b>Fuel temp sensor (FTS)</b> 	522	0.75	W	FLR91X-A	Fuel temp sensor signal	ECU 5 (5)	22	1
	531	0.75	B	FLR91X-A	Fuel temp sensor GND	ECU 5 (5)	31	2
<b>Coolant temperature sensor (CTS)</b> 	135	0.75	Brn	FLR91X-A	Coolant temperature sensor signal	ECU 1 (1)	35	1
	134	0.75	B	FLR91X-A	Coolant temperature sensor GND	ECU 1 (1)	34	2
<b>Check Conn (CHECK)</b> 	501B	0.75	Y	FLR91X-A_T14	CAN 1 low	SP_08		1
	504B	0.75	G	FLR91X-A_T14	CAN 1 high	SP_09		2
	416B	0.75	B	FLR91X-A	Battery ground 1	SP_01		3
	401B	0.75	R	FLR91X-A	Battery plus 1	SP_04		4
	419B	0.75	G	FLR91X-A	Key on (T15)	SP_07		6
	607B	0.75	W	FLR91X-A_T15	CAN 2 high	SP_10		8
	608B	0.75	Y	FLR91X-A_T15	CAN 2 low	SP_11		7

# 11. Electrical System

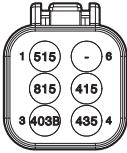
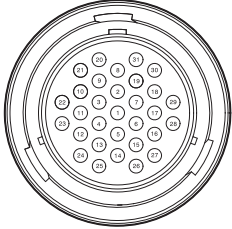
Figure	Circuit	Wire size	Color	Insulation	Circuit description	From	Pin	Connector Pin																																																																						
Inter conn 3 (INT 3) 	515	1.5	RG	FLR91X-A	Switch battery output RH12	Inter conn 2 (INT 2)	18	1																																																																						
	815	1.5	RV	FLR91X-A	Switch battery output RH33	Inter conn 2 (INT 2)	19	2																																																																						
	403B	1.5	R	FLR91X-A	Switch battery output RH21	SP_12		3																																																																						
	435	0.75	R	FLR91X-A	Air heater lamp high	ECU 4	35	4																																																																						
	415	1.5	W	FLR91X-A	Air heater lamp low	ECU 4	15	5																																																																						
Inter conn 1 (INT 1)  <table border="1" data-bbox="145 1115 432 1630"> <tr><td>1</td><td>2</td><td>3</td><td>4</td><td>5</td></tr> <tr><td>416A</td><td>414A</td><td>411A</td><td>421</td><td>420</td></tr> <tr><td>6</td><td>7</td><td>8</td><td>9</td><td>10</td></tr> <tr><td>519</td><td>803</td><td>818</td><td>401A</td><td>404A</td></tr> <tr><td>11</td><td>12</td><td>13</td><td>14</td><td>15</td></tr> <tr><td>407A</td><td>419A</td><td>425</td><td>426</td><td>427</td></tr> <tr><td>16</td><td>17</td><td>18</td><td>19</td><td>20</td></tr> <tr><td>428</td><td>429</td><td>430</td><td>503</td><td>417</td></tr> <tr><td>21</td><td>22</td><td>23</td><td>24</td><td>25</td></tr> <tr><td>507</td><td>513</td><td>501A</td><td>504A</td><td>607A</td></tr> <tr><td>26</td><td>27</td><td>28</td><td>29</td><td>30</td></tr> <tr><td>608A</td><td>432</td><td>436</td><td>506</td><td>505</td></tr> <tr><td>31</td><td></td><td></td><td></td><td></td></tr> <tr><td>806</td><td></td><td></td><td></td><td></td></tr> </table>	1	2	3	4	5	416A	414A	411A	421	420	6	7	8	9	10	519	803	818	401A	404A	11	12	13	14	15	407A	419A	425	426	427	16	17	18	19	20	428	429	430	503	417	21	22	23	24	25	507	513	501A	504A	607A	26	27	28	29	30	608A	432	436	506	505	31					806					416A	1.5	B	FLR91X-A	Battery ground 1	SP_01		1
	1	2	3	4	5																																																																									
	416A	414A	411A	421	420																																																																									
	6	7	8	9	10																																																																									
	519	803	818	401A	404A																																																																									
	11	12	13	14	15																																																																									
	407A	419A	425	426	427																																																																									
	16	17	18	19	20																																																																									
	428	429	430	503	417																																																																									
	21	22	23	24	25																																																																									
507	513	501A	504A	607A																																																																										
26	27	28	29	30																																																																										
608A	432	436	506	505																																																																										
31																																																																														
806																																																																														
414A	1.5	B	FLR91X-A	Battery ground 2	SP_02		2																																																																							
411A	1.5	B	FLR91X-A	Battery ground 4	SP_03		3																																																																							
421	0.75	Y	FLR91X-A	Emergency stop switch	ECU 4 (4)	21	4																																																																							
420	0.75	W	FLR91X-A	Droop switch	ECU 4 (4)	20	5																																																																							
519	0.75	W	FLR91X-A	50/60 Hz switch	Inter conn 2 (INT 2)	17	6																																																																							
803	1.5	G	FLR91X-A	Idle/run switch	Inter conn 2 (INT 2)	16	7																																																																							
818	1.5	Y	FLR91X-A	AUX input switch	Inter conn 2 (INT 2)	15	8																																																																							

# 11. Electrical System

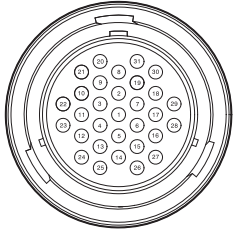
Figure	Circuit	Wire size	Color	Insulation	Circuit description	From	Pin	Connector Pin																																																																						
<p>Inter conn 1 (INT 1)</p>  <table border="1" data-bbox="145 943 432 1458"> <tr><td>1</td><td>2</td><td>3</td><td>4</td><td>5</td></tr> <tr><td>416A</td><td>414A</td><td>411A</td><td>421</td><td>420</td></tr> <tr><td>6</td><td>7</td><td>8</td><td>9</td><td>10</td></tr> <tr><td>519</td><td>803</td><td>818</td><td>401A</td><td>404A</td></tr> <tr><td>11</td><td>12</td><td>13</td><td>14</td><td>15</td></tr> <tr><td>407A</td><td>419A</td><td>425</td><td>426</td><td>427</td></tr> <tr><td>16</td><td>17</td><td>18</td><td>19</td><td>20</td></tr> <tr><td>428</td><td>429</td><td>430</td><td>503</td><td>417</td></tr> <tr><td>21</td><td>22</td><td>23</td><td>24</td><td>25</td></tr> <tr><td>507</td><td>513</td><td>501A</td><td>504A</td><td>607A</td></tr> <tr><td>26</td><td>27</td><td>28</td><td>29</td><td>30</td></tr> <tr><td>608A</td><td>432</td><td>436</td><td>506</td><td>505</td></tr> <tr><td>31</td><td></td><td></td><td></td><td></td></tr> <tr><td>806</td><td></td><td></td><td></td><td></td></tr> </table>	1	2	3	4	5	416A	414A	411A	421	420	6	7	8	9	10	519	803	818	401A	404A	11	12	13	14	15	407A	419A	425	426	427	16	17	18	19	20	428	429	430	503	417	21	22	23	24	25	507	513	501A	504A	607A	26	27	28	29	30	608A	432	436	506	505	31					806					401A	1.5	R	FLR91X-A	Battery plus 1	SP_04		9
	1	2	3	4	5																																																																									
	416A	414A	411A	421	420																																																																									
	6	7	8	9	10																																																																									
	519	803	818	401A	404A																																																																									
	11	12	13	14	15																																																																									
	407A	419A	425	426	427																																																																									
	16	17	18	19	20																																																																									
	428	429	430	503	417																																																																									
	21	22	23	24	25																																																																									
	507	513	501A	504A	607A																																																																									
	26	27	28	29	30																																																																									
	608A	432	436	506	505																																																																									
	31																																																																													
	806																																																																													
	404A	1.5	R	FLR91X-A	Battery plus 2	SP_05		10																																																																						
	407A	1.5	R	FLR91X-A	Battery plus 4	SP_06		11																																																																						
	419A	0.75	G	FLR91X-A	Key on (T15)	SP_07		12																																																																						
	425	0.75	B	FLR91X-A_T07	Acc. pedal position sensor 2 GND	ECU 4 (4)	25	13																																																																						
	426	0.75	W	FLR91X-A_T07	Acc. pedal position sensor 2 SIG	ECU 4 (4)	26	14																																																																						
	427	0.75	O	FLR91X-A_T07	Acc. pedal position sensor 2 PWR	ECU 4 (4)	27	15																																																																						
	428	0.75	B	FLR91X-A_T08	Acc. pedal position sensor 1 GND	ECU 4 (4)	28	16																																																																						
	429	0.75	Y	FLR91X-A_T08	Acc. pedal position sensor 1 SIG	ECU 4 (4)	29	17																																																																						
	430	0.75	R	FLR91X-A_T08	Acc. pedal position sensor 1 PWR	ECU 4 (4)	30	18																																																																						
	503	1.5	G	FLR91X-A	T50 input	Inter conn 2 (INT 2)	3	19																																																																						
	417	1.5	G	FLR91X-A	Crank lamp	ECU 4 (4)	17	20																																																																						
	507	1.5	GrL	FLR91X-A_T11	Starter relay high	Inter conn 2 (INT 2)	4	21																																																																						
	513	1.5	GGr	FLR91X-A_T11	Starter relay low	Inter conn 2 (INT 2)	5	22																																																																						
	501A	1.5	Y	FLR91X-A_T10	CAN 1 low	SP_08		23																																																																						
	504A	1.5	G	FLR91X-A_T10	CAN 1 high	SP_09		24																																																																						
	607A	0.75	W	FLR91X-A_T13	CAN 2 low	SP_10		25																																																																						
608A	0.75	Y	FLR91X-A_T13	CAN 2 high	SP_11		26																																																																							
432	0.75	W	FLR91X-A_T16	AUX input SIG	ECU 4 (4)	32	27																																																																							
436	0.75	B	FLR91X-A_T16	AUX input GND	ECU 4 (4)	36	28																																																																							
506	1.5	G	FLR91X-A	Run lamp	Inter conn 2 (INT 2)	12	29																																																																							
505	1.5	Y	FLR91X-A	Wait to disconnect lamp	Inter conn 2 (INT 2)	13	30																																																																							
806	1.5	LW	FLR91X-A	Over speed lamp	Inter conn 2 (INT 2)	14	31																																																																							

# 11. Electrical System

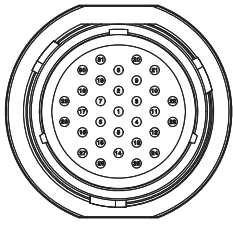
Figure	Circuit	Wire size	Color	Insulation	Circuit description	From	Pin	Connector Pin																																																																						
<p>Inter conn 2 (INT 2) (Non-air heater)</p>  <table border="1" data-bbox="145 678 432 1193"> <tr><td>1</td><td>2</td><td>3</td><td>4</td><td>5</td></tr> <tr><td>125</td><td>126</td><td>503</td><td>507</td><td>513</td></tr> <tr><td>6</td><td>7</td><td>8</td><td>9</td><td>10</td></tr> <tr><td>501</td><td>504</td><td>607</td><td>608</td><td>-</td></tr> <tr><td>11</td><td>12</td><td>13</td><td>14</td><td>15</td></tr> <tr><td>-</td><td>506</td><td>505</td><td>806</td><td>818</td></tr> <tr><td>16</td><td>17</td><td>18</td><td>19</td><td>20</td></tr> <tr><td>803</td><td>519</td><td>515</td><td>815</td><td>-</td></tr> <tr><td>21</td><td>22</td><td>23</td><td>24</td><td>25</td></tr> <tr><td>-</td><td>-</td><td>-</td><td>-</td><td>-</td></tr> <tr><td>26</td><td>27</td><td>28</td><td>29</td><td>30</td></tr> <tr><td>-</td><td>-</td><td>-</td><td>-</td><td>-</td></tr> <tr><td>31</td><td></td><td></td><td></td><td></td></tr> <tr><td>-</td><td></td><td></td><td></td><td></td></tr> </table>	1	2	3	4	5	125	126	503	507	513	6	7	8	9	10	501	504	607	608	-	11	12	13	14	15	-	506	505	806	818	16	17	18	19	20	803	519	515	815	-	21	22	23	24	25	-	-	-	-	-	26	27	28	29	30	-	-	-	-	-	31					-					125	0.75	Y	FLR91X-A	EGT sensor LH signal	EGT sensor LH (EGTL)	2	1
	1	2	3	4	5																																																																									
	125	126	503	507	513																																																																									
	6	7	8	9	10																																																																									
	501	504	607	608	-																																																																									
	11	12	13	14	15																																																																									
	-	506	505	806	818																																																																									
	16	17	18	19	20																																																																									
	803	519	515	815	-																																																																									
	21	22	23	24	25																																																																									
	-	-	-	-	-																																																																									
	26	27	28	29	30																																																																									
	-	-	-	-	-																																																																									
	31																																																																													
	-																																																																													
	126	0.75	B	FLR91X-A	EGT sensor LH GND	EGT sensor LH (EGTL)	1	2																																																																						
	503	1.5	G	FLR91X-A	TSO input	ECU 5 (5)	3	3																																																																						
	507	1.5	GrL	FLR91X-A T02	Starter relay high	ECU 5 (5)	7	4																																																																						
	513	1.5	GGr	FLR91X-A T02	Starter relay low	ECU 5 (5)	13	5																																																																						
	501	1.5	Y	FLR91X-A T01	CAN 1 low	ECU 5 (5)	1	6																																																																						
504	1.5	G	FLR91X-A_T09	CAN 1 high	SP_09		7																																																																							
607	0.75	W	FLR91X-A T03	CAN 2 high	ECU 6 (6)	7	8																																																																							
608	0.75	Y	FLR91X-A T03	CAN 2 low	ECU 6 (6)	8	9																																																																							
506	1.5	G	FLR91X-A	Run lamp	ECU 5 (5)	6	12																																																																							
505	1.5	Y	FLR91X-A	Wait to disconnect lamp	ECU 5 (5)	5	13																																																																							
806	1.5	LW	FLR91X-A	Over speed lamp	ECU 8 (8)	6	14																																																																							
818	1.5	Y	FLR91X-A	AUX input switch	ECU 8 (8)	18	15																																																																							
803	1.5	G	FLR91X-A	Idle/run switch	ECU 8 (8)	3	16																																																																							
519	0.75	W	FLR91X-A	50/60 Hz switch	ECU 5 (5)	19	17																																																																							
515	1.5	RG	FLR91X-A	Switch battery output RH12	ECU 5 (5)	15	18																																																																							
815	1.5	RV	FLR91X-A	Switch battery output RH33	ECU 8 (8)	15	19																																																																							

# 11. Electrical System

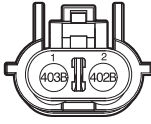
Figure	Circuit	Wire size	Color	Insulation	Circuit description	From	Pin	Connector Pin																																																																						
<p>Inter conn 2 (INT 2) (Air heater)</p>  <table border="1" data-bbox="145 745 432 1261"> <tr><td>1</td><td>2</td><td>3</td><td>4</td><td>5</td></tr> <tr><td>125</td><td>126</td><td>503</td><td>507</td><td>513</td></tr> <tr><td>6</td><td>7</td><td>8</td><td>9</td><td>10</td></tr> <tr><td>501</td><td>504</td><td>607</td><td>608</td><td>-</td></tr> <tr><td>11</td><td>12</td><td>13</td><td>14</td><td>15</td></tr> <tr><td>-</td><td>506</td><td>505</td><td>806</td><td>818</td></tr> <tr><td>16</td><td>17</td><td>18</td><td>19</td><td>20</td></tr> <tr><td>803</td><td>519</td><td>515</td><td>815</td><td>403A</td></tr> <tr><td>21</td><td>22</td><td>23</td><td>24</td><td>25</td></tr> <tr><td>402</td><td>-</td><td>-</td><td>-</td><td>-</td></tr> <tr><td>26</td><td>27</td><td>28</td><td>29</td><td>30</td></tr> <tr><td>-</td><td>-</td><td>-</td><td>-</td><td>-</td></tr> <tr><td>31</td><td></td><td></td><td></td><td></td></tr> <tr><td>-</td><td></td><td></td><td></td><td></td></tr> </table>	1	2	3	4	5	125	126	503	507	513	6	7	8	9	10	501	504	607	608	-	11	12	13	14	15	-	506	505	806	818	16	17	18	19	20	803	519	515	815	403A	21	22	23	24	25	402	-	-	-	-	26	27	28	29	30	-	-	-	-	-	31					-					125	0.75	Y	FLR91X-A	EGT sensor LH signal	EGT sensor LH (EGTL)	2	1
	1	2	3	4	5																																																																									
	125	126	503	507	513																																																																									
	6	7	8	9	10																																																																									
	501	504	607	608	-																																																																									
	11	12	13	14	15																																																																									
	-	506	505	806	818																																																																									
	16	17	18	19	20																																																																									
	803	519	515	815	403A																																																																									
	21	22	23	24	25																																																																									
	402	-	-	-	-																																																																									
	26	27	28	29	30																																																																									
	-	-	-	-	-																																																																									
	31																																																																													
	-																																																																													
	126	0.75	B	FLR91X-A	EGT sensor LH GND	EGT sensor LH (EGTL)	1	2																																																																						
	503	1.5	G	FLR91X-A	TSO input	ECU 5 (5)	3	3																																																																						
	507	1.5	GrL	FLR91X-A T02	Starter relay high	ECU 5 (5)	7	4																																																																						
	513	1.5	GGr	FLR91X-A T02	Starter relay low	ECU 5 (5)	13	5																																																																						
	501	1.5	Y	FLR91X-A T01	CAN 1 low	ECU 5 (5)	1	6																																																																						
	504	1.5	G	FLR91X-A_T09	CAN 1 high	SP_09		7																																																																						
607	0.75	W	FLR91X-A T03	CAN 2 high	ECU 6 (6)	7	8																																																																							
608	0.75	Y	FLR91X-A T03	CAN 2 low	ECU 6 (6)	8	9																																																																							
506	1.5	G	FLR91X-A	Run lamp	ECU 5 (5)	6	12																																																																							
505	1.5	Y	FLR91X-A	Wait to disconnect lamp	ECU 5 (5)	5	13																																																																							
806	1.5	LW	FLR91X-A	Over speed lamp	ECU 8 (8)	6	14																																																																							
818	1.5	Y	FLR91X-A	AUX input switch	ECU 8 (8)	18	15																																																																							
803	1.5	G	FLR91X-A	Idle/run switch	ECU 8 (8)	3	16																																																																							
519	0.75	W	FLR91X-A	50/60 Hz switch	ECU 5 (5)	19	17																																																																							
515	1.5	RG	FLR91X-A	Switch battery output RH12	ECU 5 (5)	15	18																																																																							
815	1.5	RV	FLR91X-A	Switch battery output RH33	ECU 8 (8)	15	19																																																																							
403A	1.5	R	FLR91X-A	Air heater relay high/switch battery output RH21	SP_12		20																																																																							
402	1.5	Brn	FLR91X-A	Air heater relay low	ECU 4 (4)	2	21																																																																							
Air heater relay 1 (HEAT 1) (Air heater)	403A	1.5	R	FLR91X-A	Air heater relay high	S403		1																																																																						
	402A	1.5	Brn	FLR91X-A	Air heater relay low	S402		2																																																																						
Air heater relay 2 (HEAT 2) (Air heater)	403B	1.5	R	FLR91X-A	Air heater relay high	S403		1																																																																						
	402B	1.5	Brn	FLR91X-A	Air heater relay low	S402		2																																																																						

# 11. Electrical System

---

## Boost Pressure and Temperature Sensor

1. The boost pressure and temperature sensor is connected to the exhaust manifold with an O-ring and measures the absolute pressure and temperature in the exhaust manifold.
2. The output signal is transmitted to the ECU which calculates the boost pressure based on the programmed characteristics curve.

## Engine Oil Pressure and Temperature Sensor

The engine oil pressure and temperature sensor detects the pressure and temperature and relays the data to the electronic control unit (ECU).

## Coolant Temperature Sensor

The engine coolant temperature sensor detects the engine coolant temperature and relays the data to the electronic control unit (ECU).

## Ambient Temperature Sensor

The ambient temperature sensor detects the temperature of intake air from the air filter and conveys the data to the electronic control unit (ECU).

## Common Rail Pressure Sensor

Fuel flows through a passage from the common rail into the common rail pressure sensor.

The tip of the sensor is sealed with a diaphragm, and pressurized fuel reaches the sensor diaphragm through a hole.

Connected to this diaphragm, the sensor converts fuel pressure into an electrical signal; then, the signal generated by the sensor amplifies the measurement signal and transmits it to the ECU where it enters the evaluation circuit.

## Crankshaft Speed Sensor

The position of pistons in the combustion chambers plays a very important role in fuel injection.

In every engine, pistons are connected to the crankshaft with connecting rods.

The crankshaft speed sensor installed in the flywheel housing provides information on the position of every piston. The rotation speed is defined as the number of crankshaft rotations per minute.

The main input variables are calculated in the ECU using the signals received from the crankshaft speed sensor.

## Camshaft Speed Sensor

The camshaft speed sensor controls the engine intake and exhaust valves.

Rotating at half the speed of the crankshaft, this sensor determines whether the camshaft is on the compression stroke or exhaust stroke as the pistons move toward TDC. This data cannot be detected by the crankshaft speed sensor.

However, as long as the engine is operating normally, the data generated by the crankshaft speed sensor is sufficient for determining the state of the engine.

This means that the ECU receives information on the state of the engine from the crankshaft speed sensor if the camshaft speed sensor malfunctions while the generator is in operation.

## Engine Control Unit (ECU)

### Engine Control Unit (ECU) Connectors

Engine control unit (ECU) connectors consist of connectors for connecting to the generator control panel and connectors for connecting to the engine.

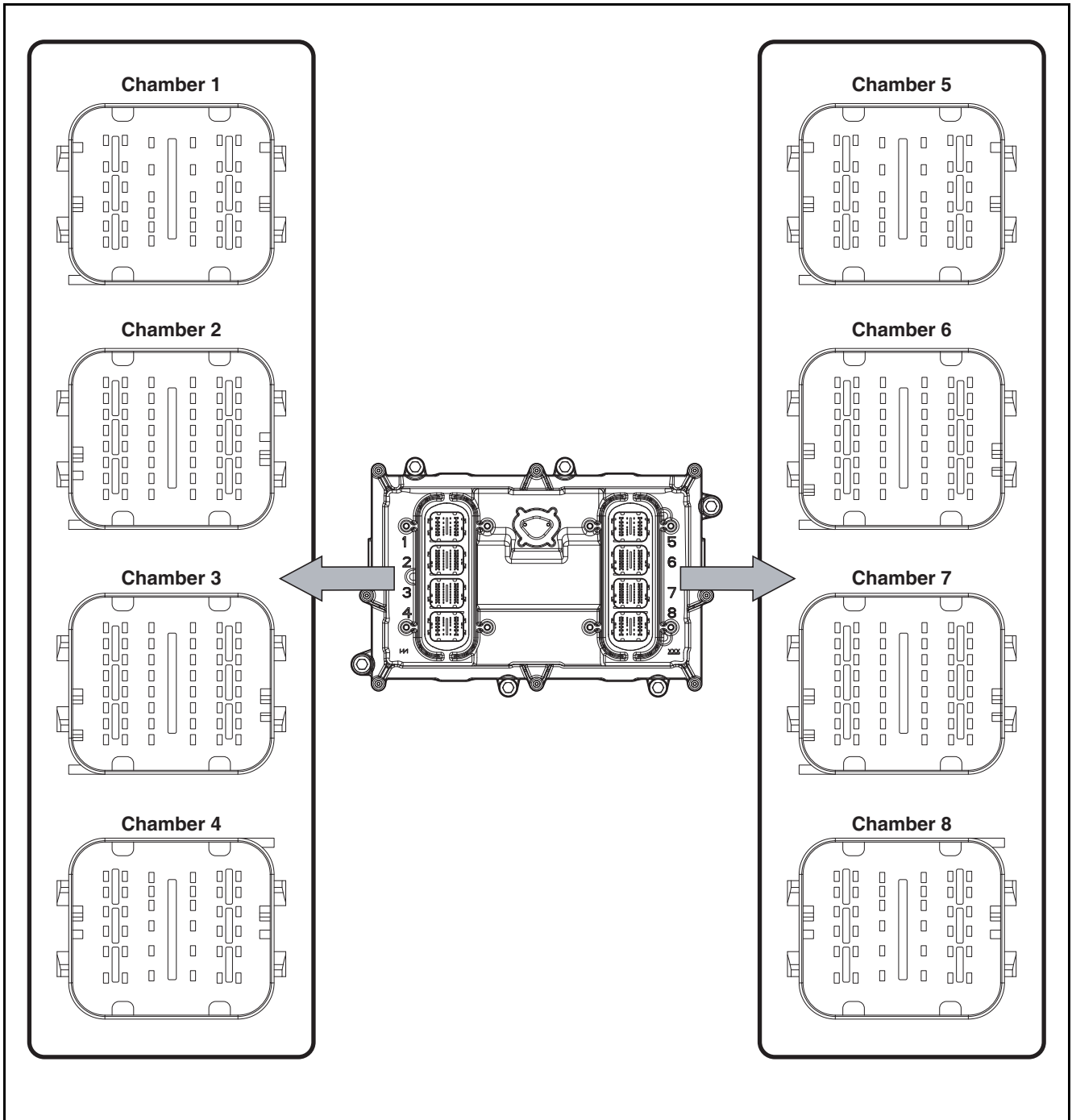

EDX22190018

# 11. Electrical System

## Engine Control Unit (ECU) Input/Output

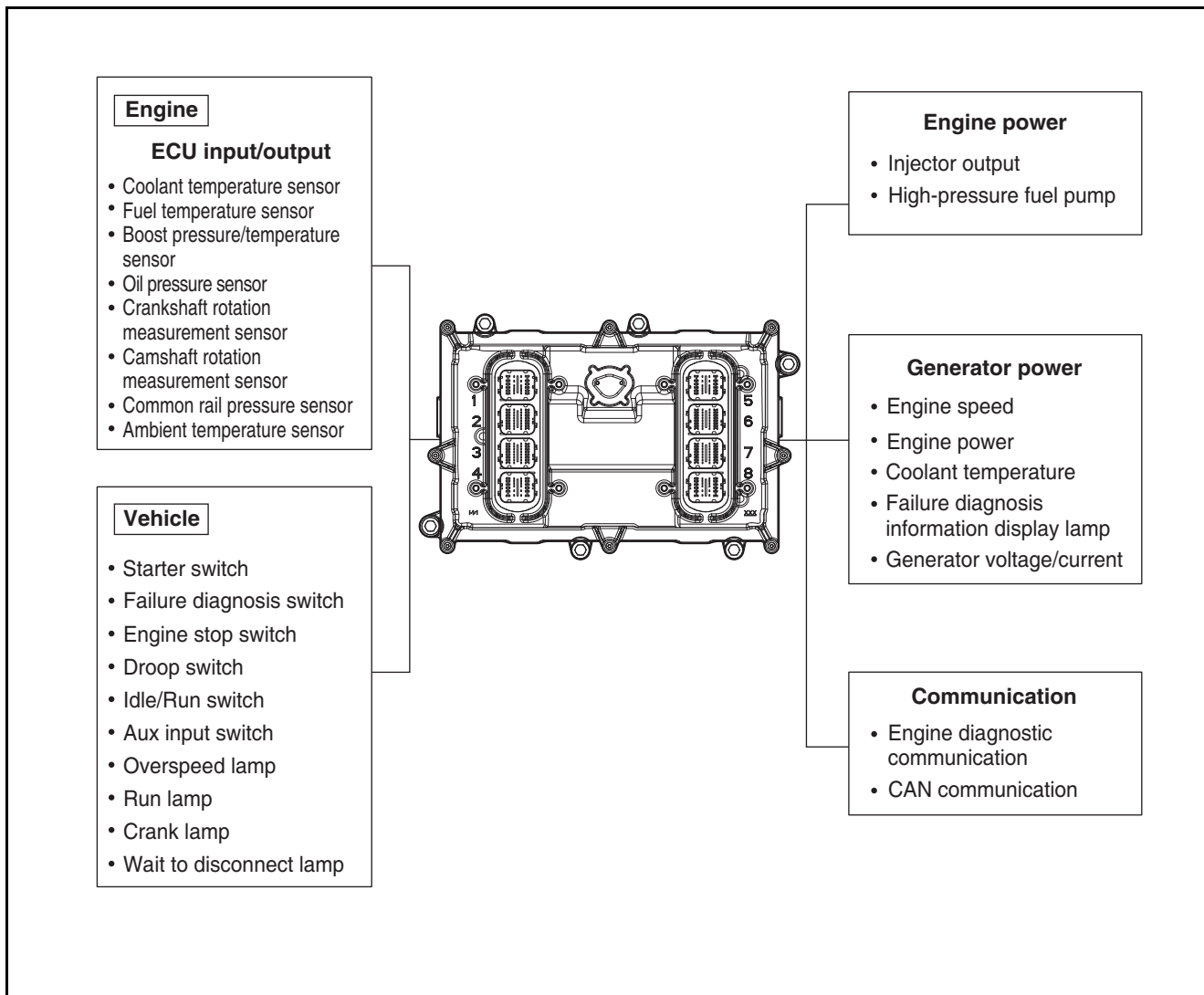

EDX15240019

### Engine Control Unit (ECU) Operating Conditions

1. Starting the engine
  - 1) To set the reference temperature for determining whether or not to perform preheating, the ECU sets the lowest temperature among the coolant temperature, fuel temperature, intake air temperature, and oil temperature as the reference temperature.
  - 2) To set the reference temperature for determining the amount of fuel, the ECU sets the engine coolant temperature as the reference temperature.
  - 3) After determining a suitable amount of fuel for starting the engine, the ECU supplies the fuel to the engine and uses the crankshaft speed sensor to measure the engine rpm signal.
2. Generator operation
  - 1) Data required for operating the generator is calculated, such as CAN communication data transmitted from the generator controller and the engine speed.
3. Fault diagnostics and restricted operation
  - 1) In the event of a fault in the engine, certain information is displayed on the control panel by CAN communication.
  - 2) Sensor malfunction: Certain alternate values are used in the event of a malfunction in any of the sensors.
  - 3) Limited output: The amount of fuel delivered to the engine is limited depending on the type of fault. There are a total of two stages, normal and abnormal, and the amount of fuel is significantly limited in the abnormal stage.
  - 4) Diagnostic information display: Data regarding faults which have occurred is provided to the operator to ensure safe operation.
4. Operating record
  - 1) Operation-related information is recorded in the engine control unit.
  - 2) Information such as the fuel consumption rate, engine operating time, and engine control unit operating time is recorded in the engine control unit.
  - 3) Information can be monitored using the ECU diagnostic system.

# 11. Electrical System

## TMS 3.0 (Option)

### Outside Drawing

#### TMS 3.0 TYPE A (LTE)

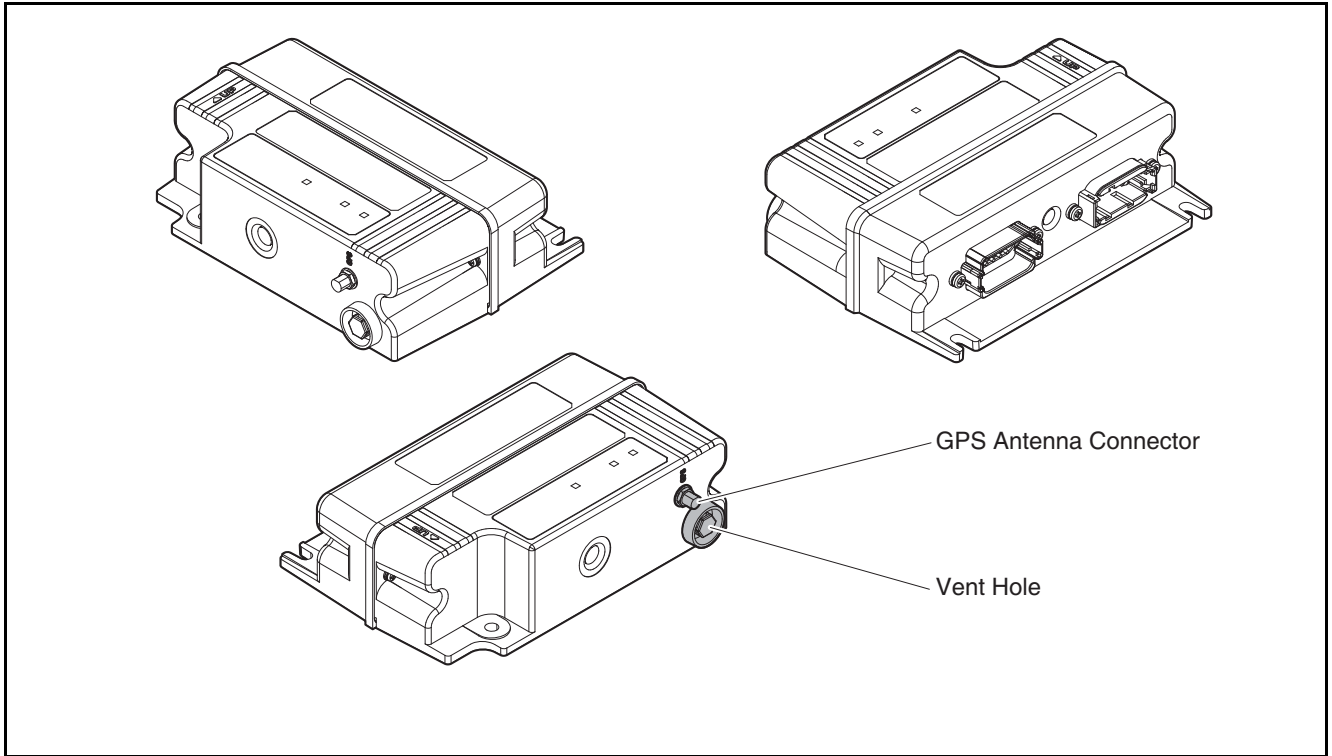

EDL06230079

#### TMS 3.0 TYPE B (LTE+SAT)

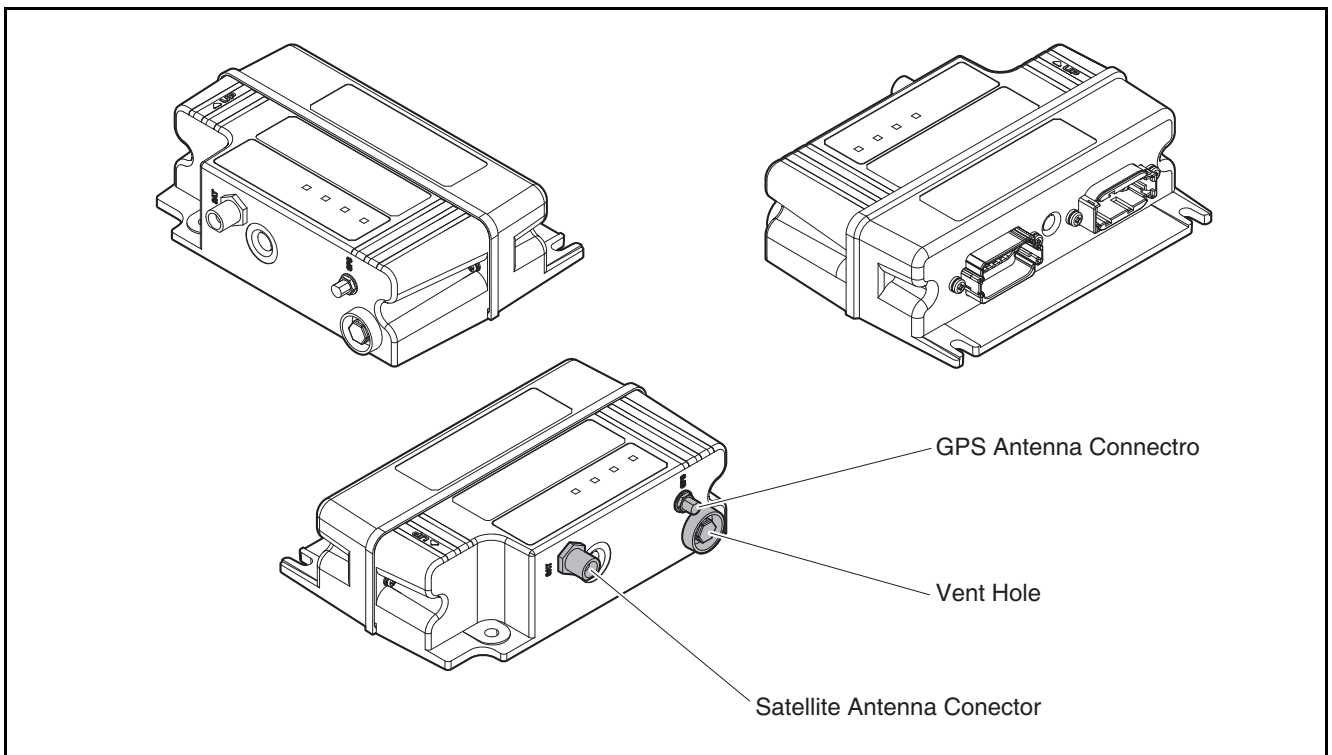

EDL06230080

## Front PIN Map

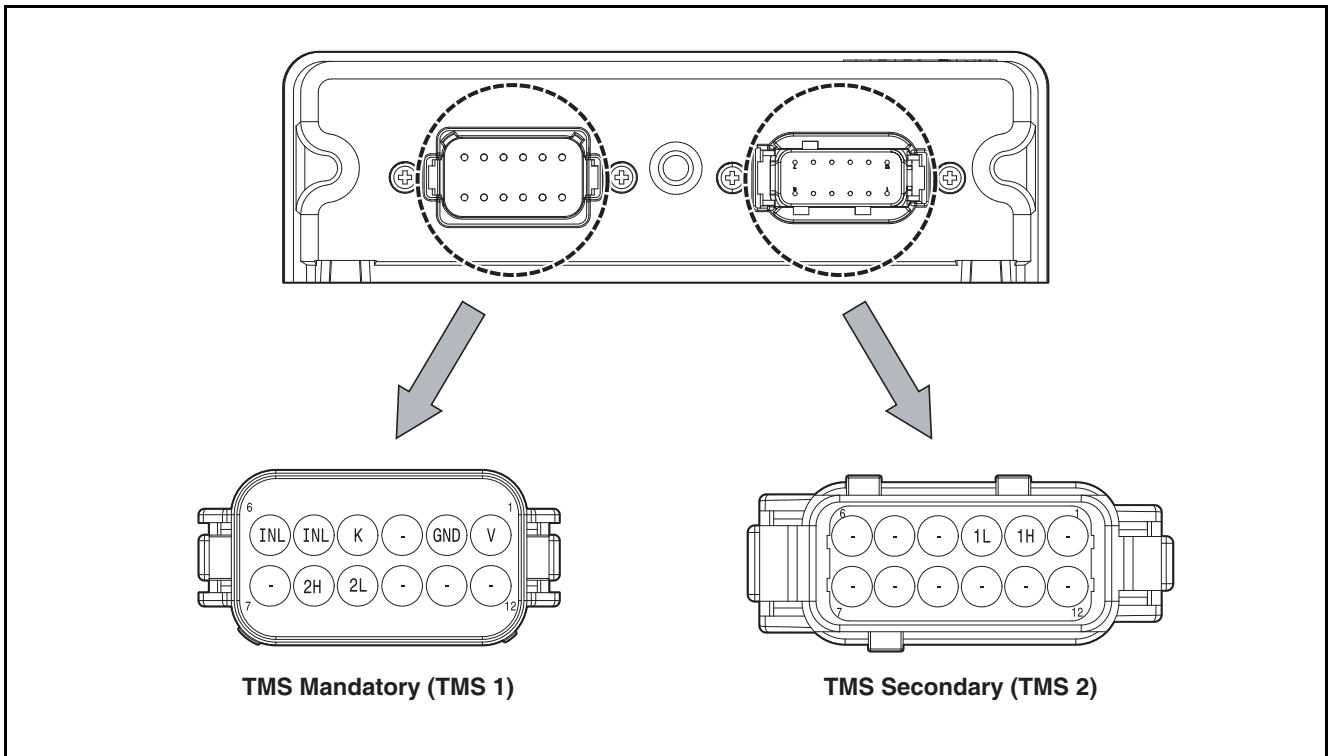

EDL08220193

No.	Circuit Description	Description
1	V	Power (24V)
2	GND	Ground
4	K	Key On
8	2H	CAN 2H
9	2L	CAN 2L

No.	Circuit Description	Description
2	1H	CAN 1H
3	1L	CAN 1L

# 11. Electrical System

---

## TMS 3.0 TYPE A (LTE) Module (EG25-G) Specification

- 1) Key Benefits
  - LTE Cat 4 Module (Max 150 Mbps (DL), Max 50 Mbps (UL))  
Worldwide LTE, UMTS/HSPA(+) and GSM/GPRS/EDGE coverage
  - Pin Compatible with EG25-X/EC20
- 2) Supported Frequency Bands
  - a) LTE-FDD: B1/B2/B3/B4/B5/B7/B8/B12/B13/B18/B19/B20/B25/B26/B28
  - b) LTE-TDD: B38/B39/B40/B41
  - c) WCDMA: B1/B2/B4/B5/B6/B8/B19
  - d) GSM: 850/900/1,800/1,900 MHz
- 3) Internet Protocol Features
  - a) Support TCP/UDP//PPP/FTP/HTTP/HTTPS/NTP/PING/QMI/NITZ  
SMTP/SPI/MQTT/CMUX/SMTSPS protocols
- 4) Key Features
  - a) (U)SIM Interface: Support USIM/SIM card: 1.8V, 3.3V
  - b) Rx-diversity: Support LTE/WCDMA Rx-diversity
  - c) Antenna Indication: ANT\_MAIN(Main antenna interface)  
ANT\_DIV(Rx-diversity antenna interface)
  - d) Physical Characteristics
    - Size: 29.0 (±0.15 mm) x 32.0 (±0.15 mm) x 2.4 (±0.2 mm)
    - Package: LGA
    - Weight: approx.4.9g
  - e) Temperature Range: -40°C to +85°C
- 5) Approvals
  - a) Carrier:
    - Deutsche Telekom (Europe)
    - Verizon/AT&T/Sprint/U.S. Cellular/T-Mobile\* (North America)
    - Telus/Rogers\* (Canada)
  - b) Regulatory:
    - GCF (Global)
    - CE (Europe)
    - FCC/PTCRB (North America)
    - IC (Canada)
    - Anatel (Brazil)
    - IFETEL (Mexico)
    - SRRC/CCC/NAL (China)
    - KC (South korea)
    - NCC (Taiwan, China)
    - RCM (Australia & New Zealand)
    - FAC\* (Russia)
    - NBTC (Thailand)
    - IMDA (Singapore)
    - ICASA (South Africa)
  - c) Others:
    - RoHS
    - WHQL

## Schematic diagram

### TMS 3.0

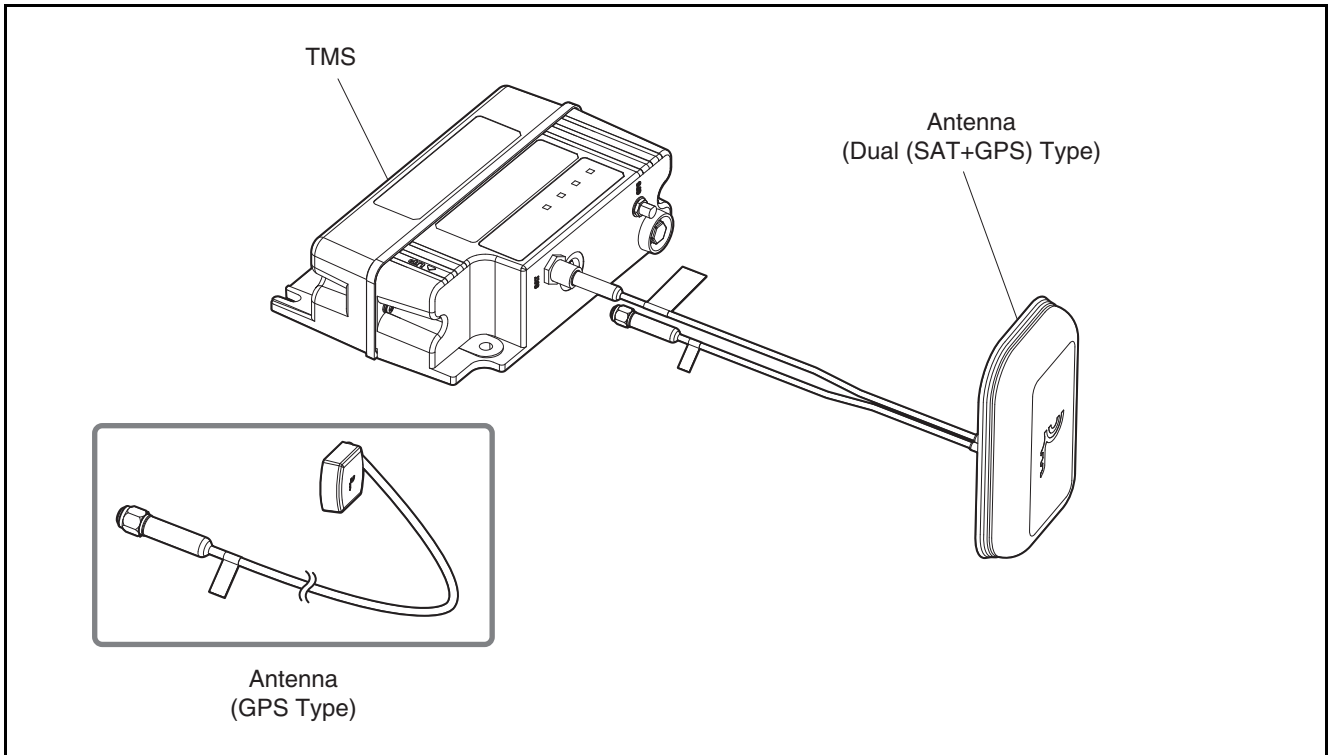

EDL06230081

# 11. Electrical System

## Connecting the TMS and engine main harness OBD

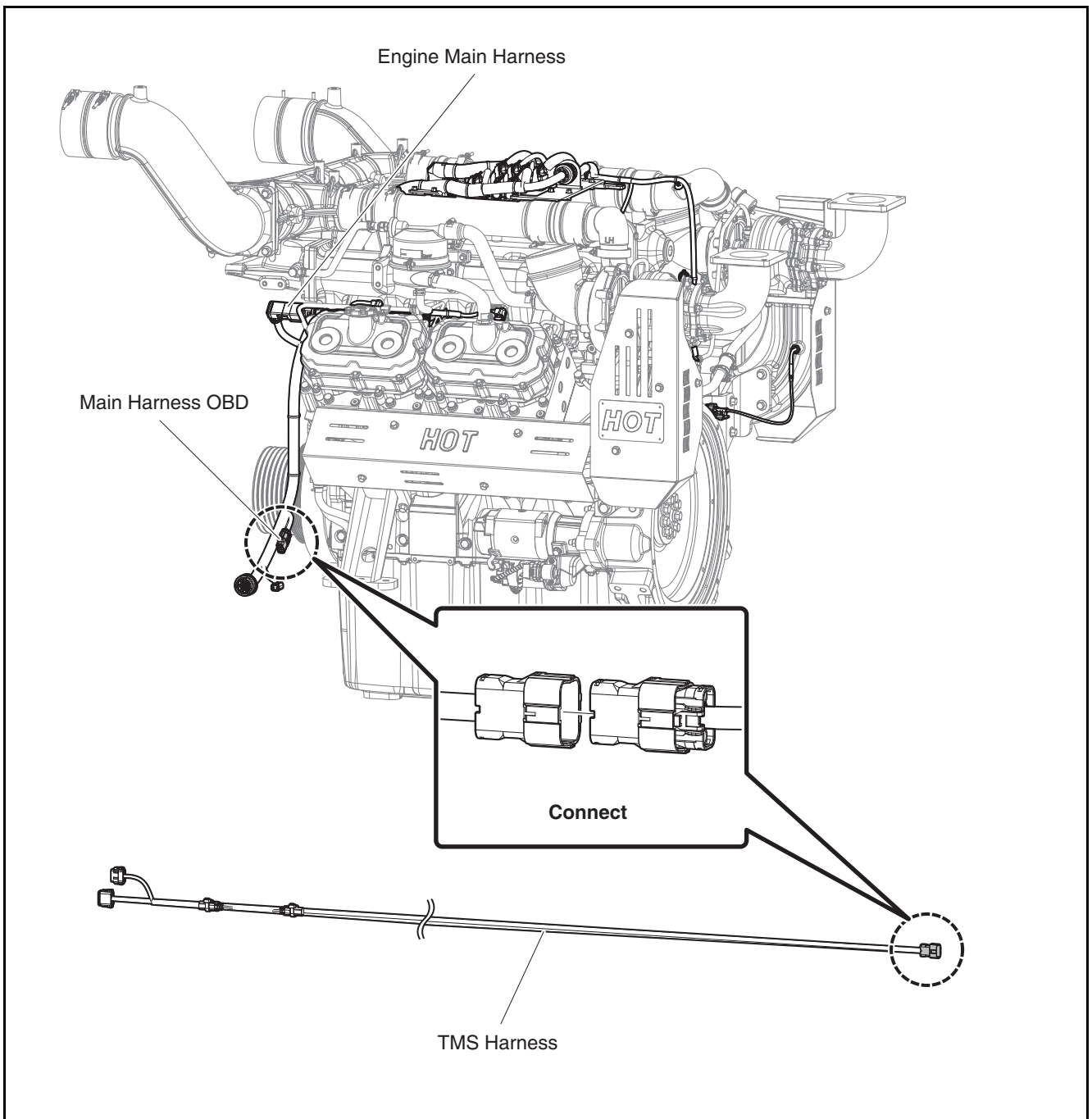

EDX15240102

Note) TMS cable size: 1.5 m, 2.5 m, 5 m, 7.5 m, 10 m, 12 m, 15 m, 20 m, 30 m, 40 m.

## Starter Motor

### General Information

The starter motor is mounted on the back of the flywheel housing.

When disassembling the engine, soak the starter motor pinion gear and ring gear in fuel and clean them thoroughly with a brush. Then, apply grease to them to prevent rust.

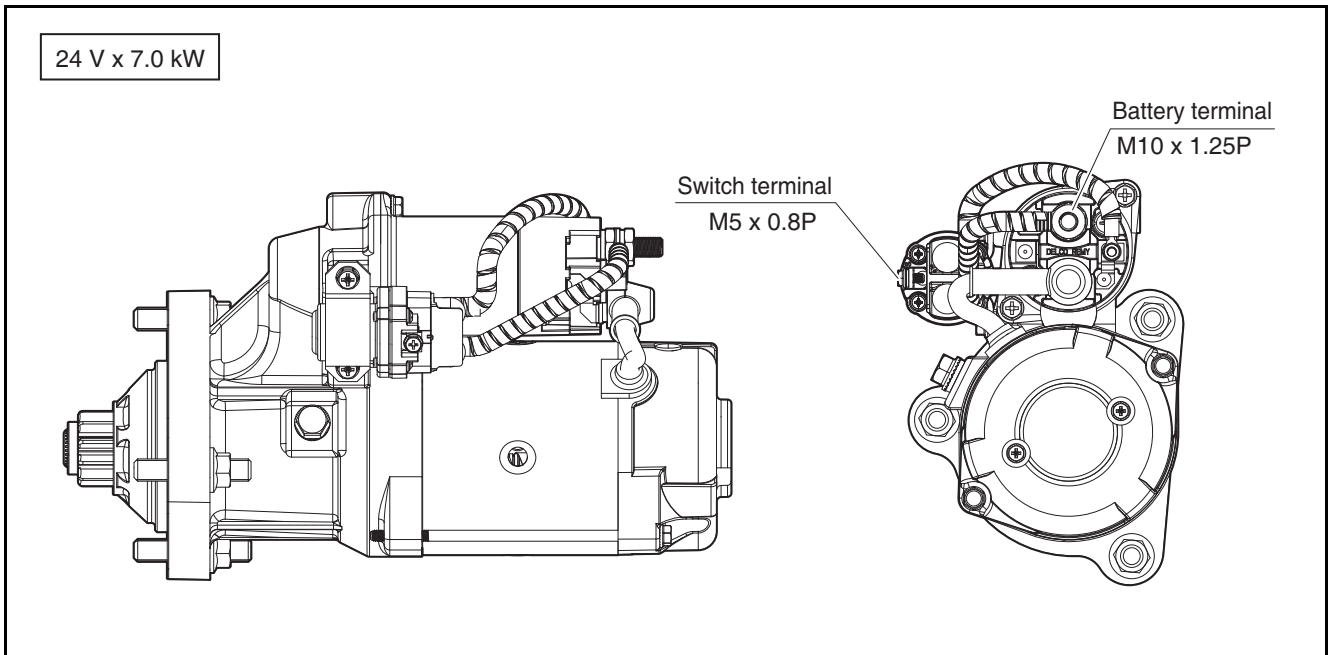

EDX15240103

### **⚠ CAUTION**

The starter motor should always be protected from moisture.

# 11. Electrical System

## Circuit Diagram

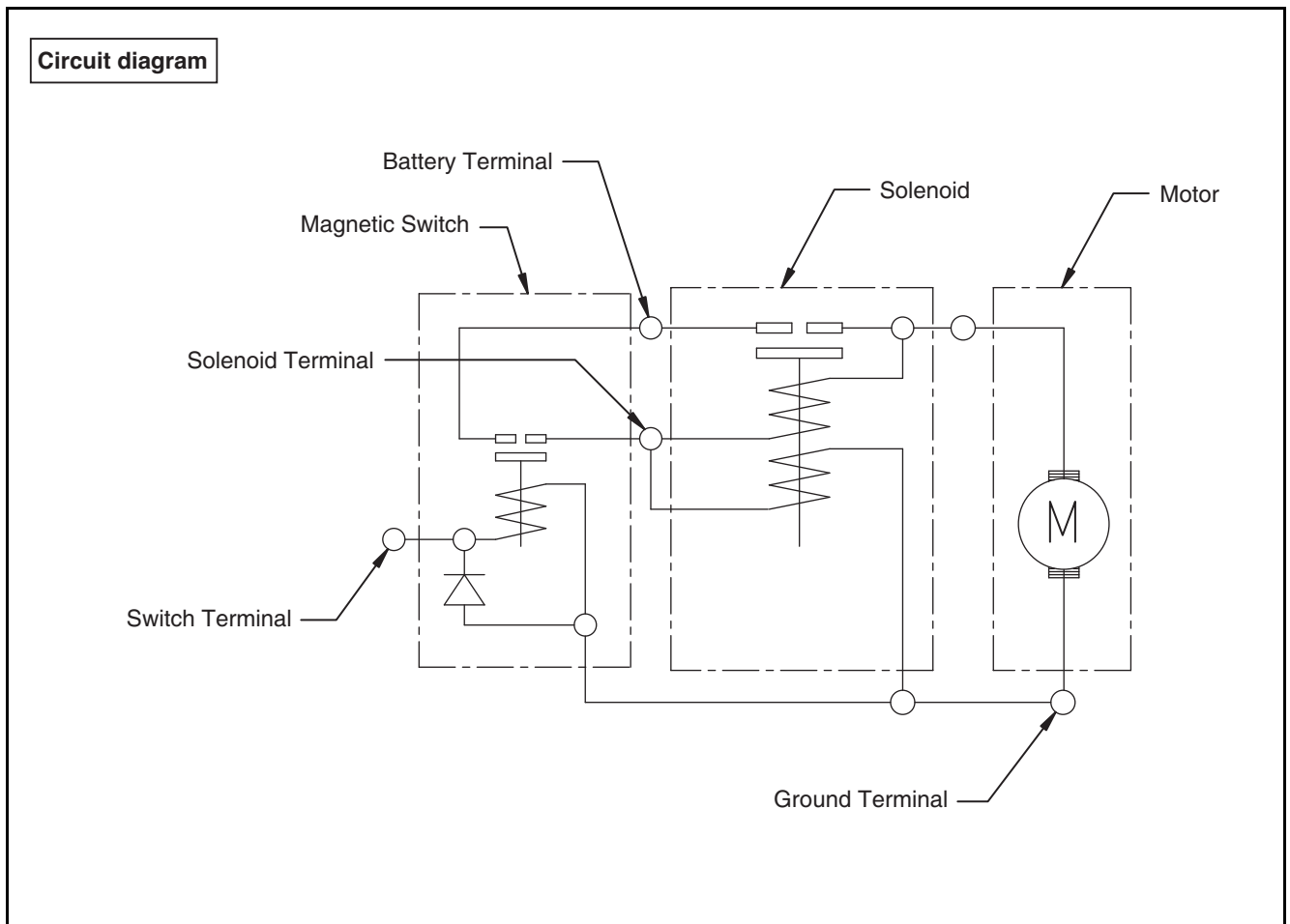

EJ9OM010

### CAUTION

Before working on any electrical system, disconnect the negative ('-') battery cable (ground cable). To prevent a short circuit, connect the ground cable only after work is complete.

## Alternator

### General Information

The alternator is equipped with a silicon rectifier. The transistor-type regulator installed in the body of the alternator restricts the voltage of the alternator. In order to prevent damage to the rectifier and regulator, do not run the alternator unless the regulator and battery are connected to the circuit.

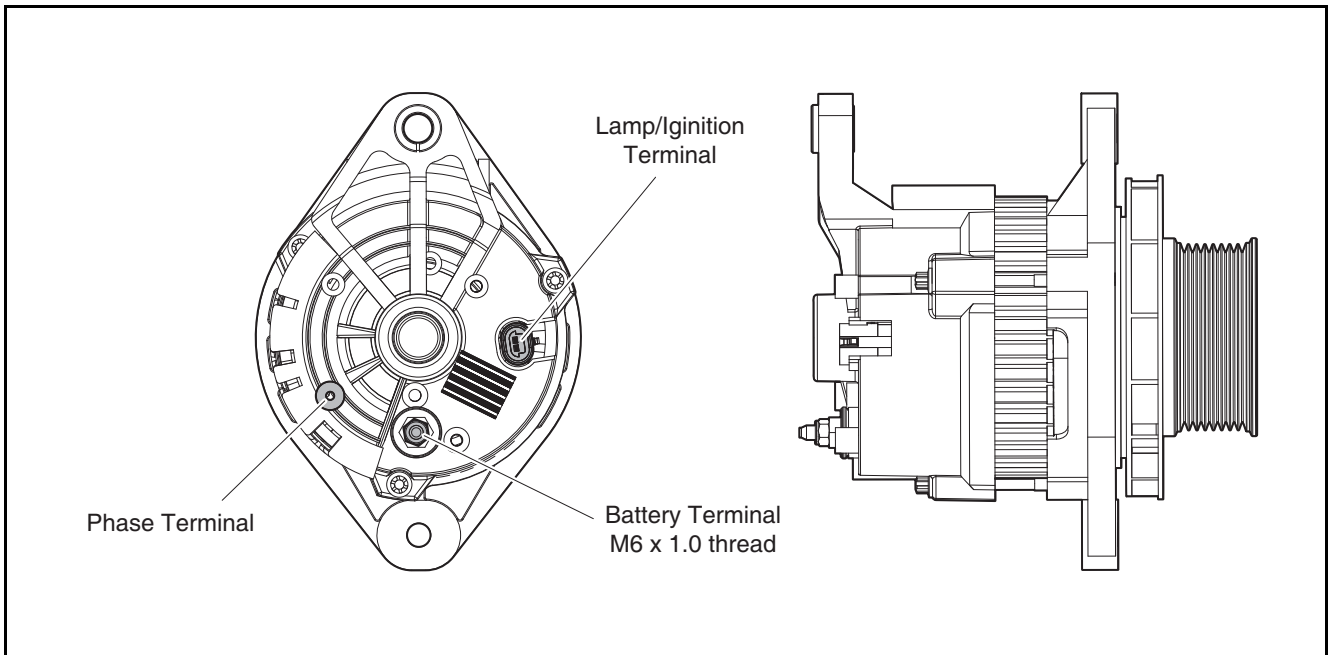

EDX15240104

### **⚠ CAUTION**

**The alternator does not require maintenance, but it must be protected from dust, moisture and water.**

# 11. Electrical System

## Circuit Diagram

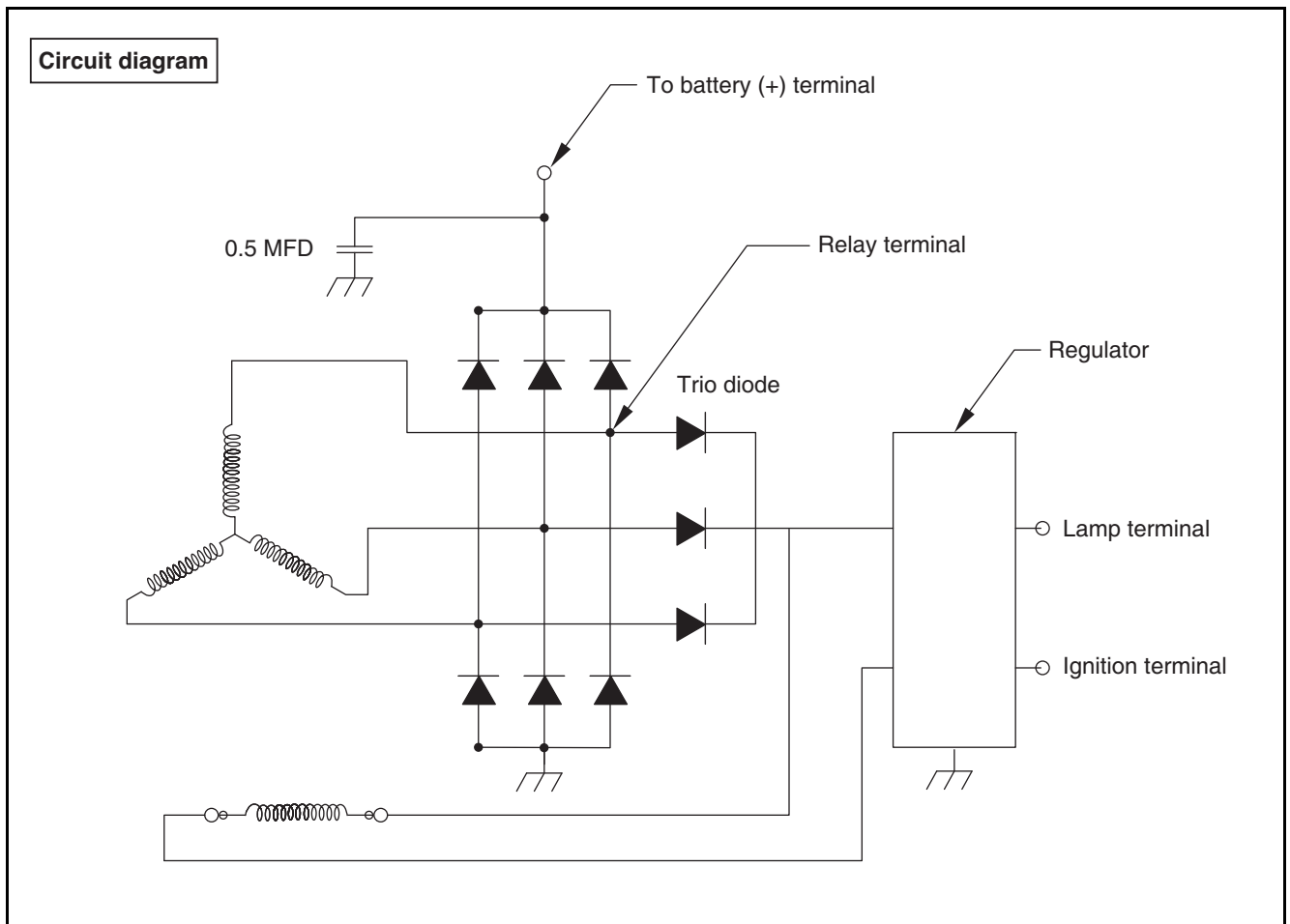

EDX22190154

### **⚠ CAUTION**

Run the alternator in accordance with the guidelines provided in this chapter.

# 12. Other/Driving System

General Information .....	183
General Information .....	183
Crankshaft .....	184
Inspecting the Crankshaft .....	184
Inspecting the Crankshaft Bearings and Connecting Rod Bearings .....	185
Pistons .....	188
Disassembling Pistons .....	188
Inspecting and Measuring .....	188
Injectors .....	191
Injector Protrusion .....	191
Miscellaneous .....	192
Engine Timing .....	192
Timing Gear Train .....	193



### General Information

#### General Information

1. Engine pistons are cooled by an oil gallery. The shape of the gallery, the shape and position of the nozzles, and the oil flow rate are all very important factors in lowering the temperature of the piston oil gallery. The cross sectional shape of the piston gallery is designed to achieve maximum cooling effectiveness with efficient oil flow.
2. The crankshaft is a forged single unit. The crankshaft and rear oil seals are designed to prevent oil from entering the flywheel housing.
3. The connecting rod is a single forged unit. Its big end can be disconnected diagonally, enabling it to be removed with the piston through the top of the cylinder. Prefabricated alloy bearings are used in the moving parts of the crankshaft and connecting rods.
4. The camshaft, oil pump, and high-pressure injection pump are driven by gear connections in the timing gear case.
5. The overhead valve is operated by the valve tappets, pushrods and rocker arms on the camshaft.

## 12. Other/Driving System

### Crankshaft

#### Inspecting the Crankshaft

1. Inspecting and measuring
  - 1) Visually inspect the crankshaft journal and crankpin for scratches or damage.
  - 2) Perform a magnetic particle test or liquid penetrant test (color check) to check for cracks in the crankshaft. Replace if cracked.
2. Journal and pin diameter

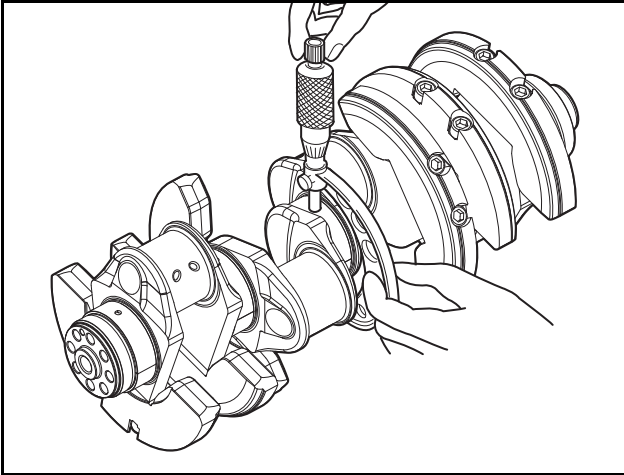

EDX15240099

- 1) Using a micrometer, measure the crankshaft journal and pin O.D. in the direction shown in the figure to check the amount of wear.
- 2) If the amount of wear exceeds the limit, polish the crankshaft journal and crankpin and install an undersize bearing.
- 3) However, if the amount of wear is below the limit, polish the part with an oil stone or fine oily sandpaper. (Make sure the fine sandpaper has been soaked in oil.)

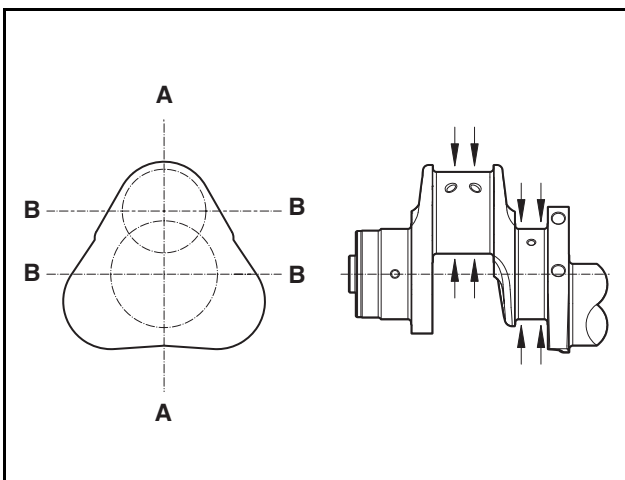

EDX22190055

- Journal and pin O.D.

Item	Reference value
Journal diameter	Ø103.98 ~ Ø104.00 mm (Ø4.0937 ~ Ø4.0945 in.)
Pin diameter	Ø93.98 ~ Ø94.00 mm (Ø3.7 ~ Ø3.7008 in.)

#### < Types of undersize bearings >

- Standard
- 0.25 (0.25 mm / 0.0098 in. smaller than standard I.D.)
- 0.50 (0.50 mm / 0.0197 in. smaller than standard I.D.)
- 0.75 (0.75 mm / 0.0295 in. smaller than standard I.D.)
- 1.00 (1.00 mm / 0.0394 in. smaller than standard I.D.)

#### ⚠ CAUTION

As shown above, there are four types of undersize bearings. The crankshaft can be ground to the measurements above.

#### ⚠ CAUTION

When grinding the crankshaft, make sure to grind part "R" on the end of the bearing precisely. There should not be any steps or burrs.

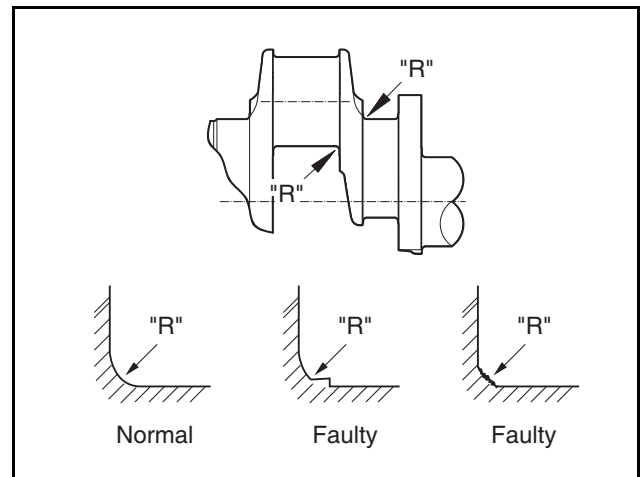

EDX22190057

#### [ Specification for section "R" ]

- "R" on the crank pin:  $4.5 \begin{smallmatrix} 0 \\ -0.5 \end{smallmatrix}$
- "R" on the crank journal:  $4.0 \begin{smallmatrix} 0 \\ -0.5 \end{smallmatrix}$

## 3. Crankshaft deflection

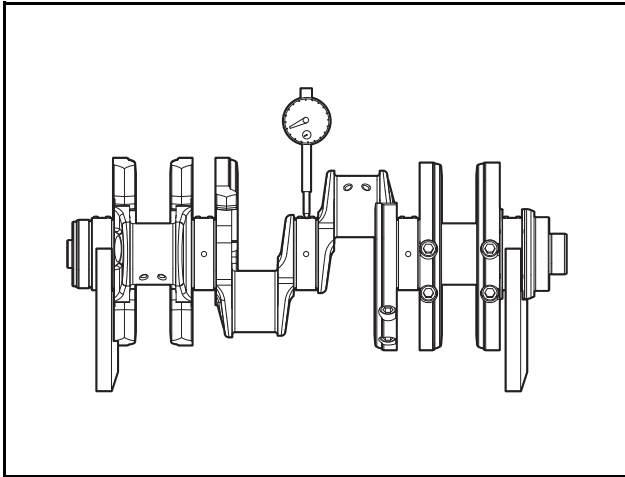

EDX15240100

- 1) Place the crankshaft on two V-blocks.
- 2) Set a dial gauge on the surface plate and roll the crankshaft to measure its deflection.
  - Crankshaft deflection

Reference value	Allowable limit
0.08 mm (0.0032 in.)	0.12 mm (0.0047 in.)

## Inspecting the Crankshaft Bearings and Connecting Rod Bearings

1. Visual inspection
  - 1) Check the crankshaft bearings and connecting rod bearings visually for uneven wear, scratches or other damage, and replace them if necessary.
2. Oil clearance between crankshaft and bearing

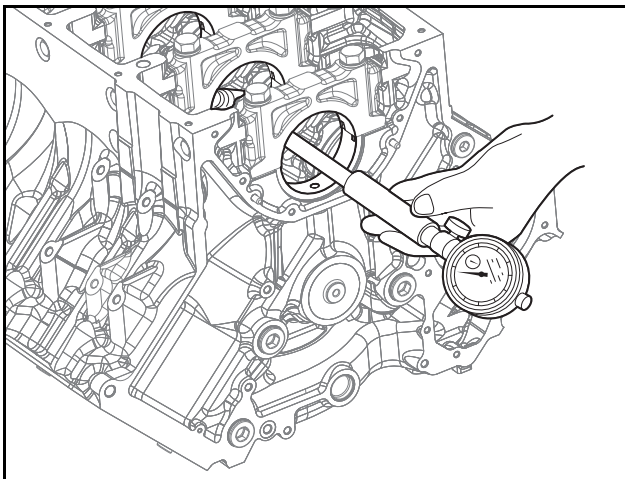

EDX22190058

- 1) Install the journal bearing on the cylinder block, tighten the bearing cap to the specified torque, and measure the inside diameter of the bearing.

Side bolt	13.4 kgf·m (96.92 lbf·ft)
Standard I.D. of journal bearing	Ø104.066 ~ Ø104.114 mm (Ø4.0971 ~ Ø4.099 in.)

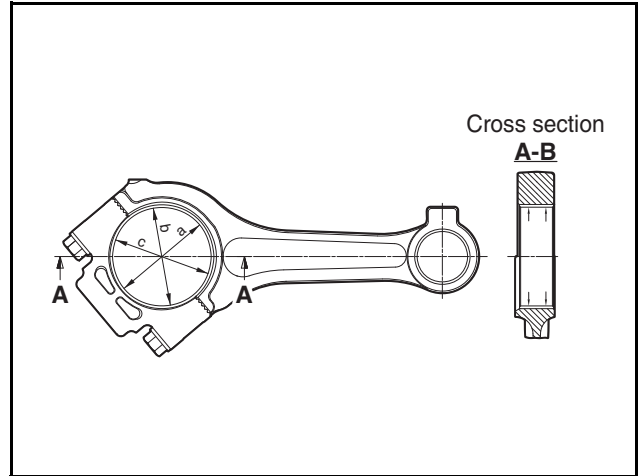

EF8OM062

- 2) Install the bearing on the big end of the connecting rod, tighten the bearing cap to the specified torque, and measure the inside diameter.

Connecting rod bearing I.D.	Ø94.056 ~ Ø94.098 mm (Ø3.703 ~ Ø3.7046 in.)
-----------------------------	--

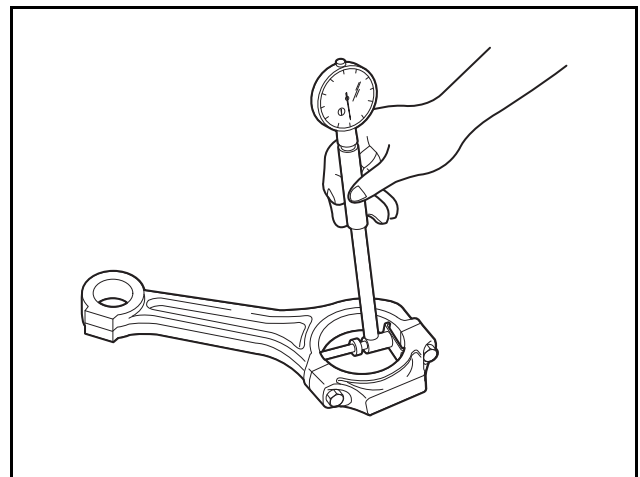

EAMD0601

3. Bearing oil clearance
  - 1) Compare the measured bearing I.D. (journal bearing, connecting rod bearing) with the measured crankshaft journal and pin O.D. to calculate the oil clearance.

Item	Reference value	Allowable limit
Journal bearing	0.066 ~ 0.134 mm (0.0026 ~ 0.0053 in.)	0.159 mm (0.0063 in.)
Connecting rod bearing	0.056 ~ 0.118 mm (0.0022 ~ 0.0046 in.)	0.143 mm (0.0056 in.)

- 2) If the clearance is beyond the limit, grind the crank journal and crankpin and select a suitable undersize bearing to use.

## 12. Other/Driving System

### 4. Inspecting the journal and connecting rod bearings

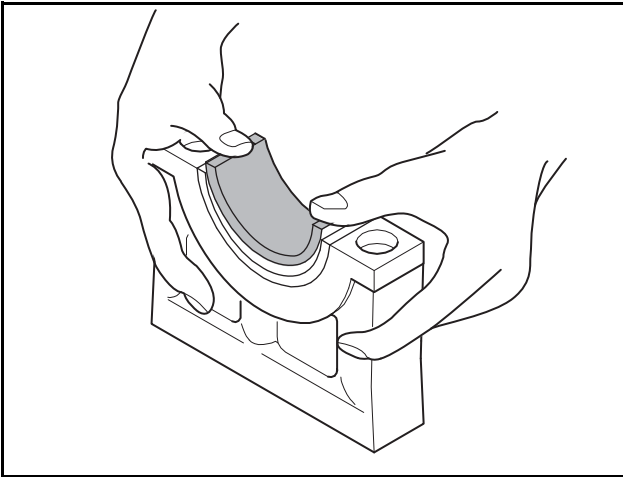

EH6OM039

- 1) When assembling the bearing as shown in the figure, check whether the bearing is sufficiently pliable and requires a significant amount of finger pressure.
- 2) When measuring the spread of the journal bearing and connecting rod bearing, use a dedicated jig as shown in the figure. However, perform the measurement with the parts assembled as shown below in order to facilitate the task.

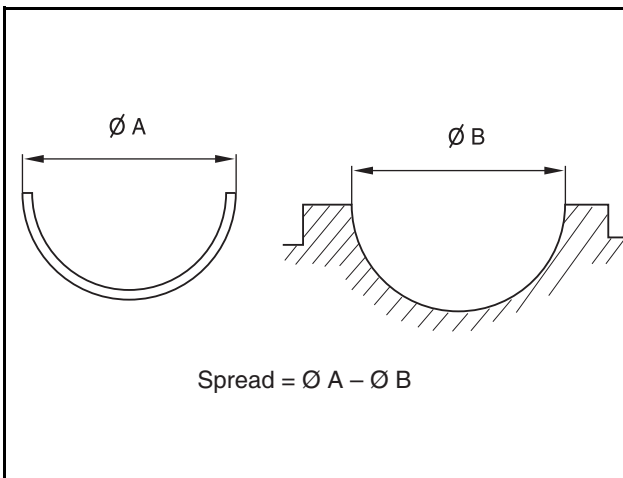

EDM20471

### 3) Journal bearing

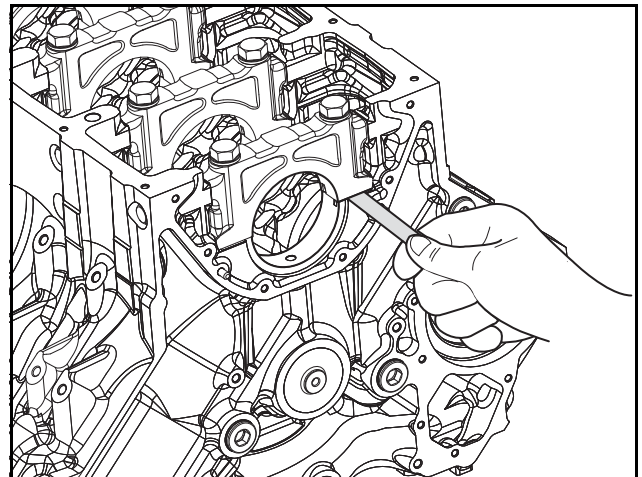

EDX22190059

- a) Install the bearings and caps on the cylinder block and tighten them to the specified torque; then, completely remove the bolts on one side and use a feeler gauge to measure the gap which naturally forms between the cylinder block and bearing cap.
  - Bearing cap clearance

Reference value	0.3 ~ 1.2 mm (0.0118 ~ 0.0472 in.)
-----------------	---------------------------------------

### 4) Connecting rod bearing

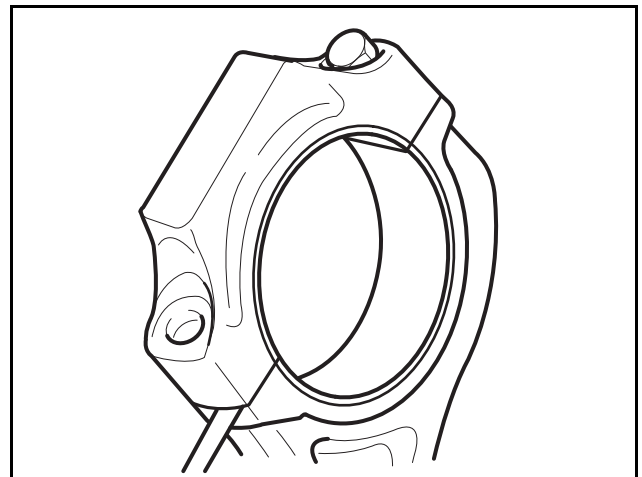

EA6M0641

- a) Install the bearing and cap on the connecting rod and tighten them to the specified torque; then, completely unscrew one of the bolts and use a feeler gauge to measure the gap which forms naturally between these parts due to the bearing.
  - Connecting rod bearing clearance

Reference value	0.5 ~ 1.4 mm (0.0197 ~ 0.0551 in.)
-----------------	---------------------------------------

### 5. Crankshaft play

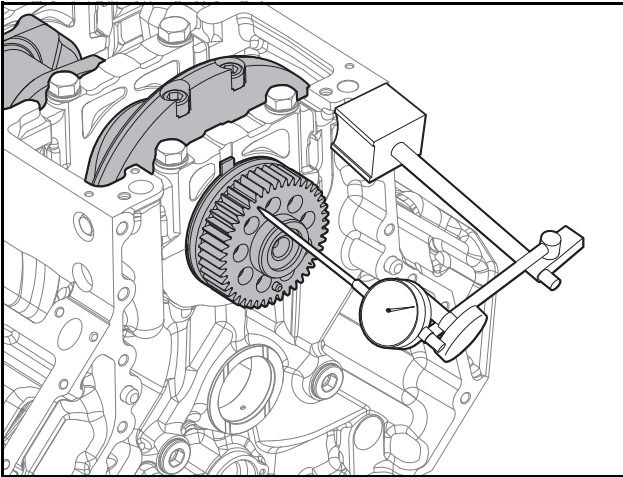

EDX22190103

1) Install the crankshaft on the cylinder block and use a dial gauge to measure the crankshaft end play.

- Crankshaft play

Reference value	Allowable limit
0.140 ~ 0.361 mm (0.0055 ~ 0.0142 in.)	0.4 mm (0.0157 in.)

# 12. Other/Driving System

## Pistons

### Disassembling Pistons

#### 1. Disassembling piston pins

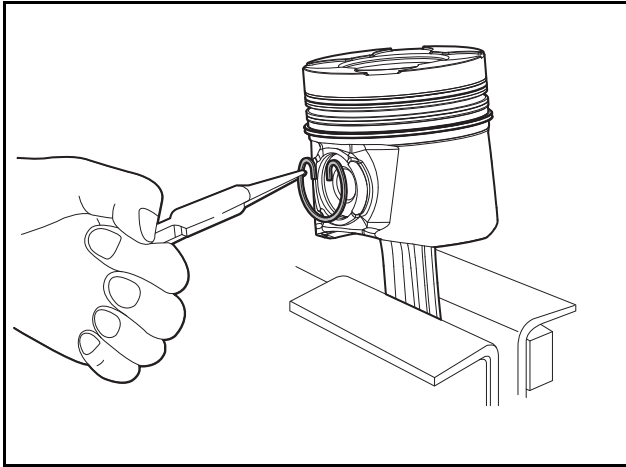

EDX22190104

- 1) Remove the piston pin snap ring with snap ring pliers.
- 2) Remove the piston pin with a round rod.

#### 2. Disassembling piston rings

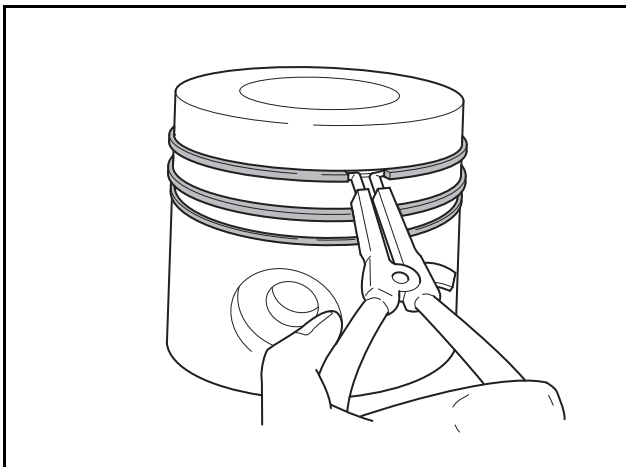

EFM20511

- 1) Remove the piston rings with pliers.
- 2) Clean the piston thoroughly.

### Inspecting and Measuring

#### 1. Visual inspection

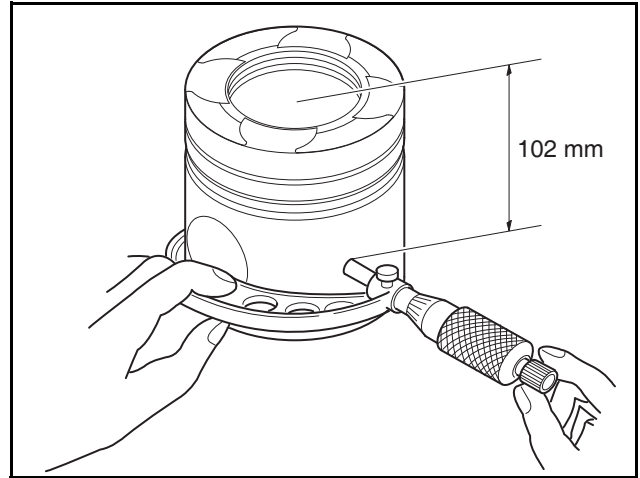

EDX22190157

- 1) Visually inspect the pistons for wear, cracks or scratches, and check the piston ring grooves with particular care.
- 2) Use a micrometer to measure the outside diameter of the piston. Measure the piston 102 mm (4.0157 in.) above the end of the piston head perpendicularly to the piston pin as shown in the figure.
  - Measure perpendicularly 102 mm (4.0157 in.) above the end of the piston head

Reference value	Ø127.833 ~ Ø127.847 mm (Ø5.0328 ~ Ø5.0333 in.)
-----------------	---

#### 2. Cylinder bore I.D.

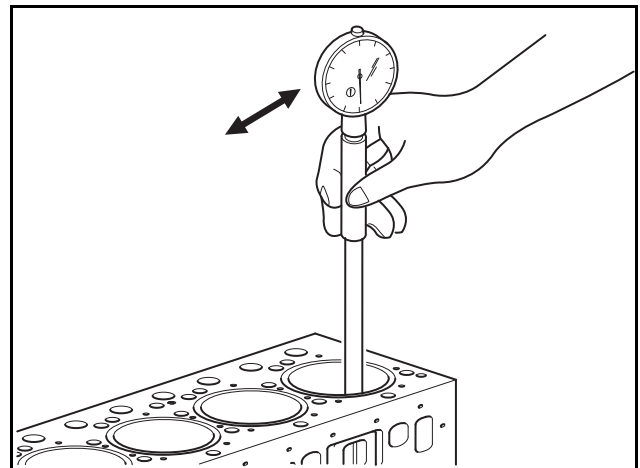

EH6OM043

- 1) Use a cylinder bore gauge to measure the inside diameter of the cylinder liner. Measure three places at 45° intervals: the top ring contact surface of the cylinder, the middle, and the bottom of the oil ring contact surface. The remainder after subtracting the maximum and minimum values is the average value.

Reference value	Ø127.99 ~ Ø128.01 mm (Ø5.0389 ~ Ø5.0398 in.)
-----------------	---

## 12. Other/Driving System

### 3. Clearance between the piston and cylinder liner

- 1) The clearance is the value of the cylinder liner I.D. minus the piston O.D. If this result exceeds the allowable limit, replace either the piston or cylinder liner depending on which part is more worn.

Reference value	0.143 ~ 0.177 mm (0.0056 ~ 0.0069 in.)
-----------------	---

### 4. Piston ring and piston ring groove

- 1) After disassembling the engine, check the piston ring for wear and damage, and repair it with a new part if necessary.

### 5. Piston ring end clearance

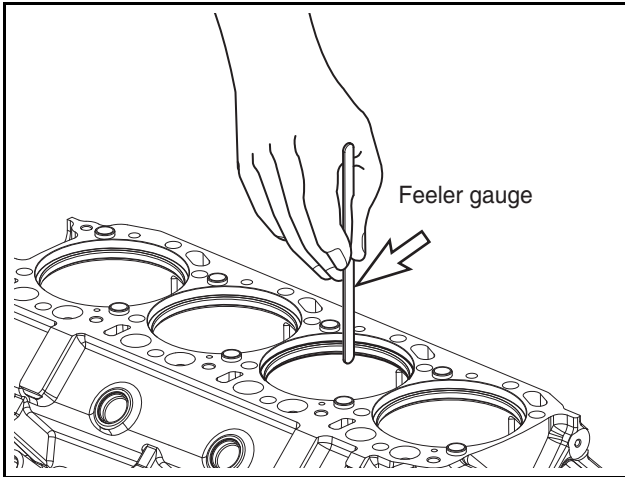

EDX15240101

- 1) Measure the cut part of the snap ring.
- 2) Insert the piston ring perpendicularly into the top of the cylinder.
- 3) Use a feeler gauge to measure the piston ring clearance.
- 4) If the measurement exceeds the limit, replace the ring.

	Reference value	Allowable limit
Top ring	0.30 ~ 0.40 mm (0.0118 ~ 0.0157 in.)	0.7 mm (0.028 in.)
Second ring	1.10 ~ 1.30 mm (0.0433 ~ 0.0512 in.)	1.45 mm (0.057 in.)
Oil ring	0.40 ~ 0.60 mm (0.0157 ~ 0.0236 in.)	0.85 mm (0.033 in.)

### 6. Piston ring side gap

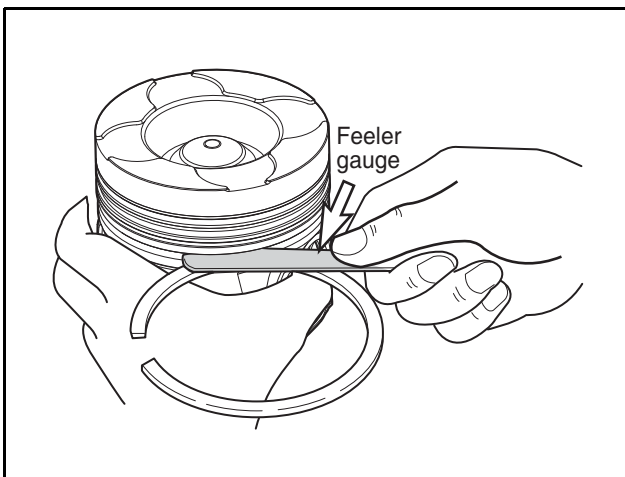

EDX22190081

- 1) Assemble the piston rings with the piston.

- 2) Measure the side gap of each ring; if the measurement exceeds the allowable limit, replace the ring or the piston.

	Reference value	Allowable limit
Top ring	0.105 ~ 0.150 mm (0.0041 ~ 0.0059 in.)	0.30 (0.012 in.)
Second ring	0.05 ~ 0.082 mm (0.0020 ~ 0.0032 in.)	0.15 mm (0.006 in.)
Oil ring	0.03 ~ 0.07 mm (0.0012 ~ 0.0028 in.)	0.15 mm (0.006 in.)

- 3) If the measurement exceeds the allowable limit, replace the ring or the piston.

### 7. Piston pins

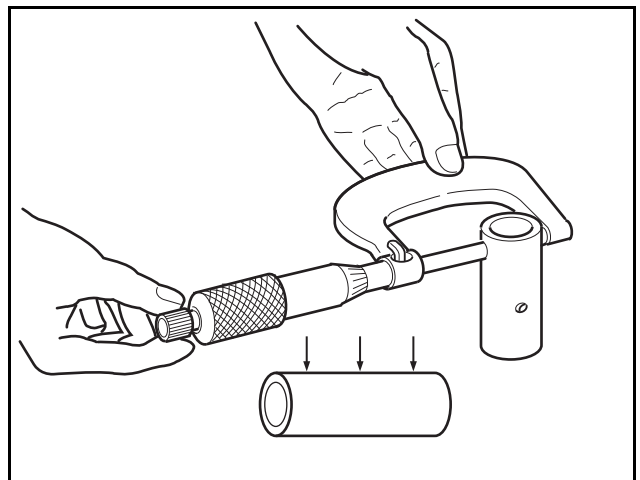

EA0M4031

- 1) Measure the outside diameter of the piston pin with an O.D. micrometer; if the measurement is equal to or less than the allowable limit, replace the pin.

Reference value	Allowable limit
Ø45.994 ~ Ø46.000 mm (Ø1.8108 ~ Ø1.8110 in.)	Ø45.979 mm (Ø1.8102 in.) or less

### 8. Clearance between piston pin and connecting rod bushing

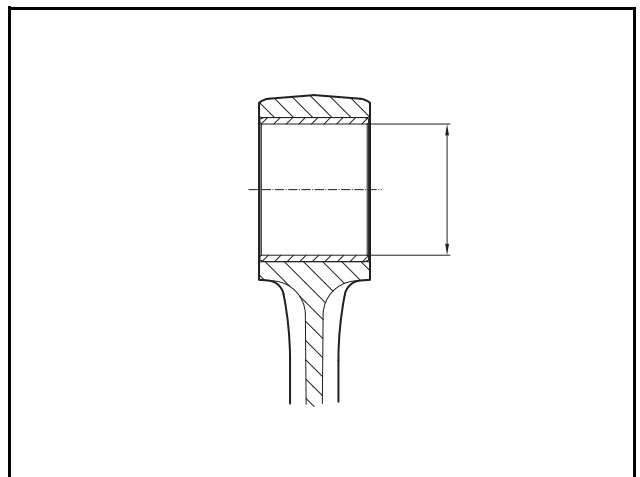

EE20M064

## 12. Other/Driving System

- 1) Measure the clearance between the piston pin and connecting rod bushing. If the measurement exceeds the usable limit, replace whichever part is more worn.

Reference value	Allowable limit
0.055 ~ 0.071 mm (0.0022 ~ 0.0028 in.)	0.13 mm (0.0051 in.)

### 9. Connecting rods

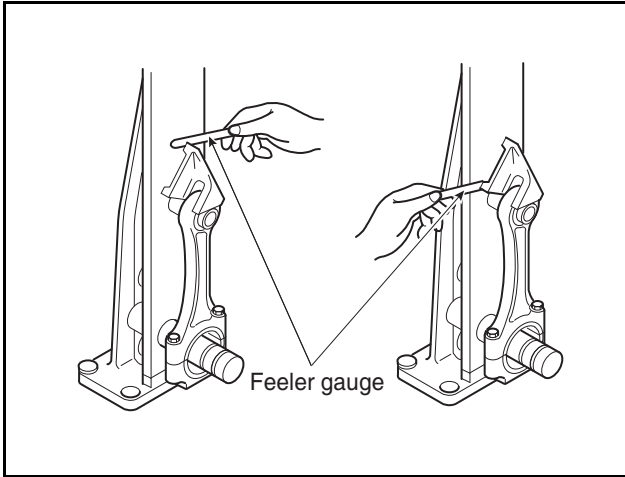

EA0M4034

- 1) Install the connecting rod on a connecting rod measuring device as shown in the figure; then, use a feeler gauge to measure the distortion. If the connecting rod is distorted, do not attempt to correct and reuse it; replace it with a new one.
- 2) Check the parallelism of the piston ring bushing hole on the connecting rod and the bearing groove at the big end of the connecting rod. Install the connecting rod on a connecting rod tester and measure it with a feeler gauge as described above.

Reference value	Allowable limit
0.02 mm (0.0008 in.)	0.1 mm (0.004 in.)

- 3) Install the connecting rod on the crankshaft and use a feeler gauge to measure the clearance between the big end of the connecting rod and the crankpin.

Reference value	Allowable limit
0.056 ~ 0.118 mm (0.0022 ~ 0.0046 in.)	0.143 mm (0.0056 in.)

- 4) Install the piston on the connecting rod and measure the clearance between the two assemblies.
- 5) If the measured clearance exceeds the limit, replace the connecting rod.

### Injectors

#### Injector Protrusion

1. Insert a seal ring into the cylinder head and assemble the injector.

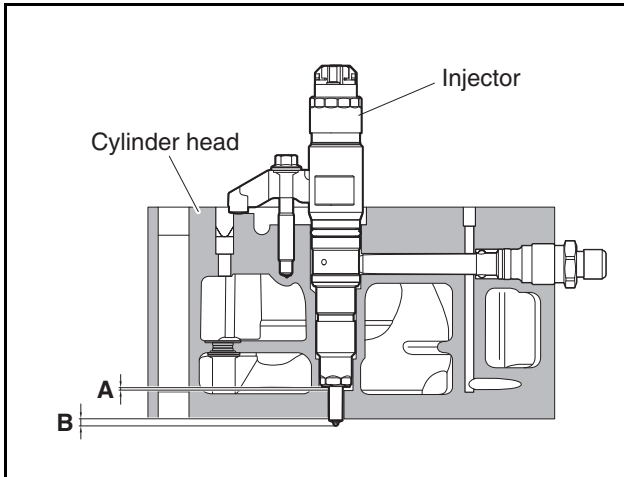

EDX22190106

2. Check the protrusion of the injector from the cylinder head; correct if necessary.

Item	Reference value
A (thickness of seal ring)	2.0 mm (0.0787 in.)
B (injector protrusion)	2.18 ~ 3.03 mm (0.0858 ~ 0.1193 in.)

## 12. Other/Driving System

### Miscellaneous

### Engine Timing

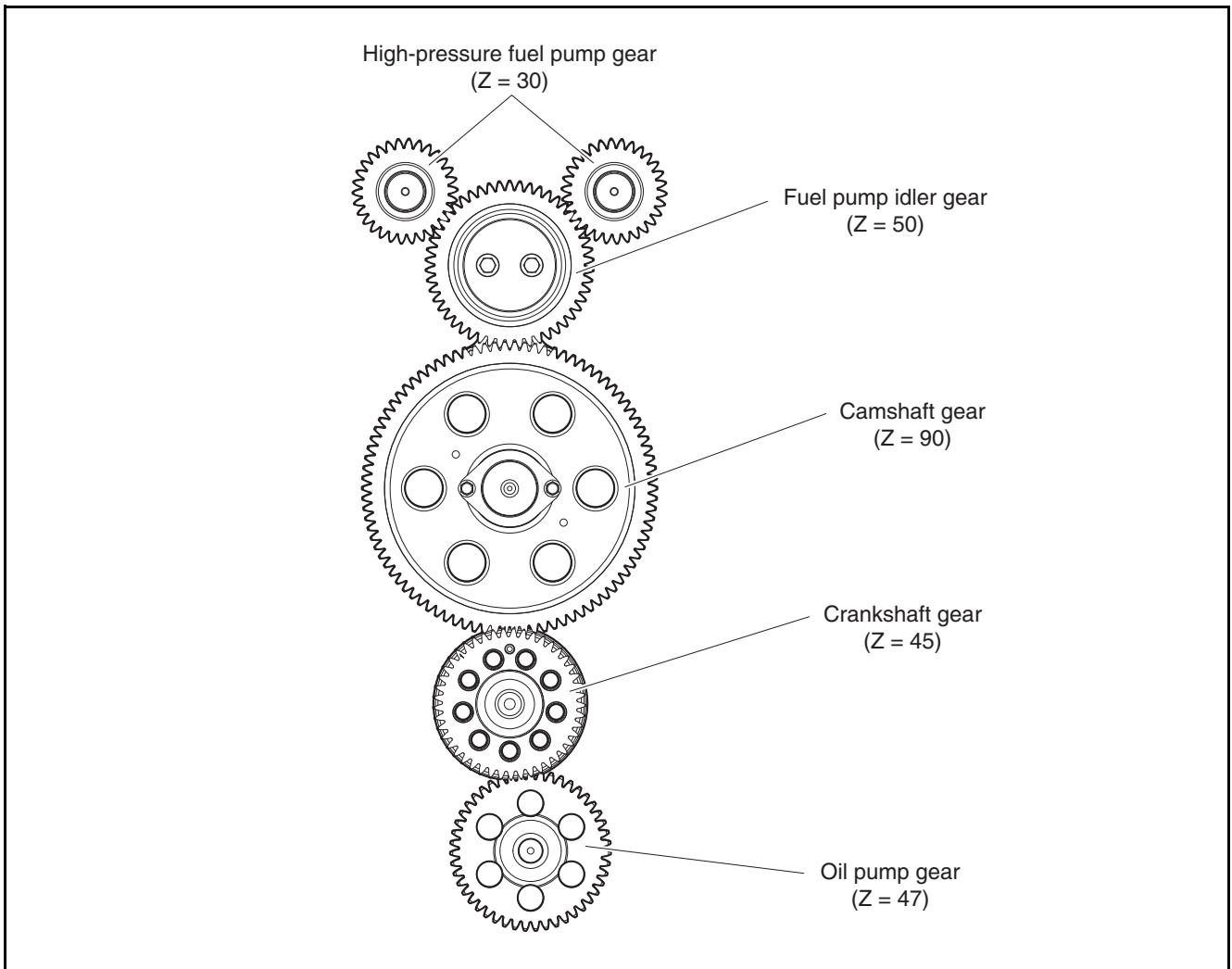

EDX22190107

### Timing Gear Train

1. Unscrew six M8 bolts and remove the brackets.

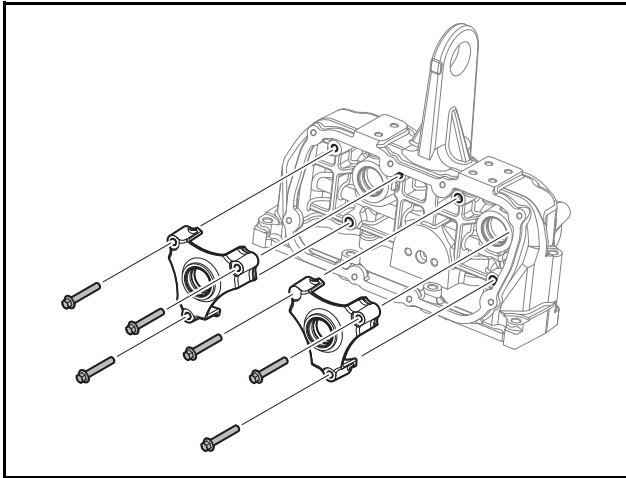

EDX22190158

2. Insert the high-pressure fuel pump gears (2 EA) into the case bushing holes and seat them on the case seat.

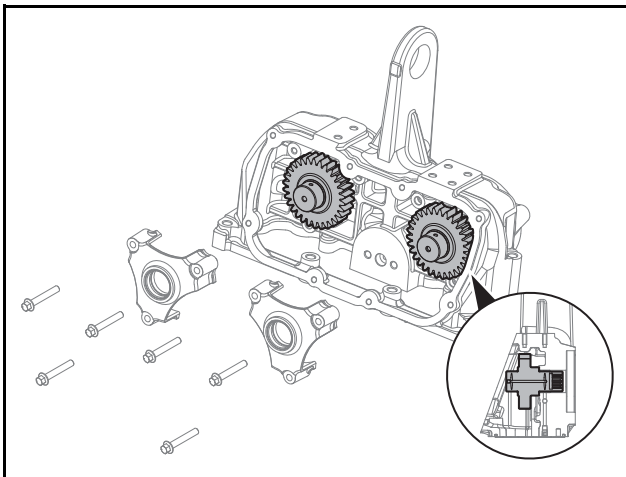

EDX22190159

3. Assemble the brackets.

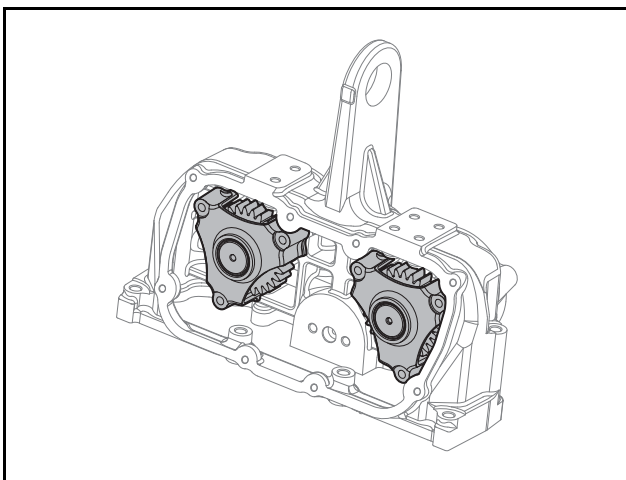

EDX22190160

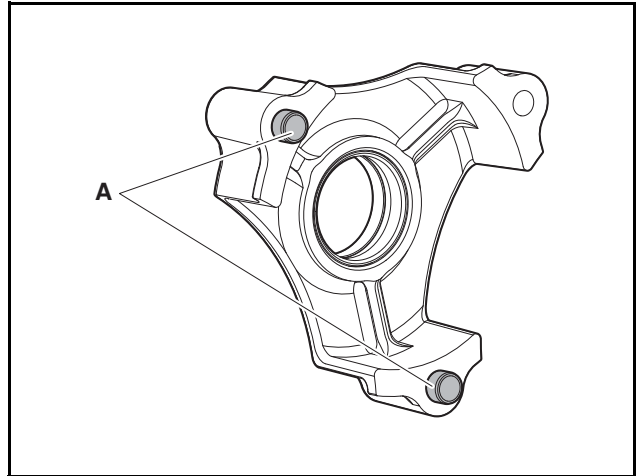

EDX22190161

- 1) Assemble bracket pins (A) while taking care not to damage them, and seat the brackets on the case seat. (Use a copper hammer)

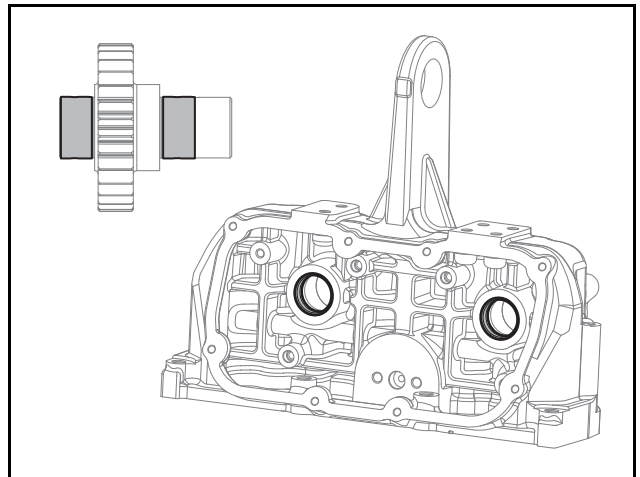

EDX22230190

- 2) During assembly, apply oil around the entire circumference of the bushing and shaft with a silicone brush at least once.
4. Tighten the M8 bolts onto the brackets.

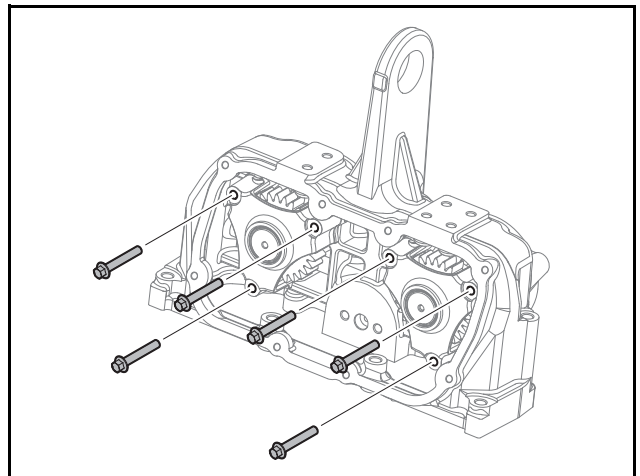

EDX22190163

<b>Tightening Torque</b>	2.2 ±0.55 kgf·m (15.9126 ±3.9782 lbf·ft)
--------------------------	--

## 12. Other/Driving System

5. Assemble fuel pump idler gear (A) and gear shaft (B).

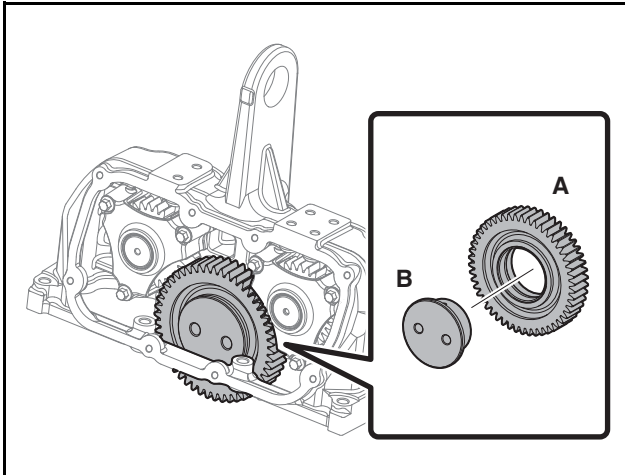

EDX22190164

6. Tighten the M10 bolts onto the gear shaft.

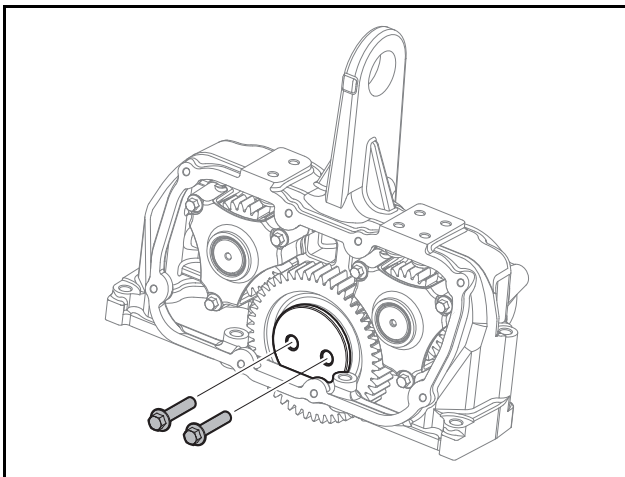

EDX22190165

<b>Tightening Torque</b>	6.2 ±1.55 kgf·m (44.8 ±11.2 lbf·ft)
--------------------------	-------------------------------------

7. After completing the assembly, rotate gears (A) and (B) to make sure that they rotate properly.

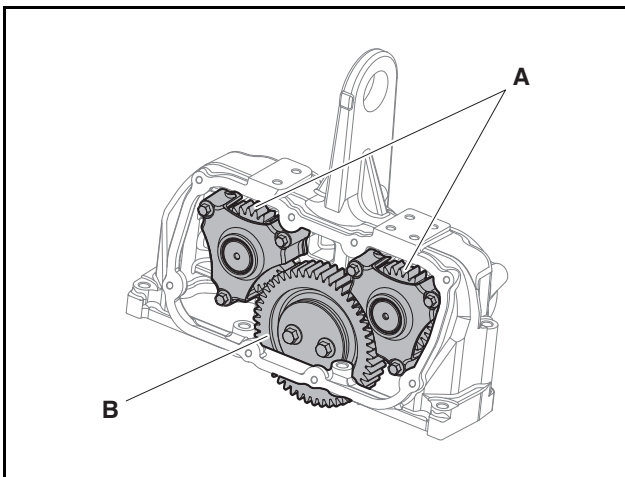

EDX22190166

# 13. Installation Guidelines

Fuel Lines .....	197
Fuel Line Installation Information .....	197
Pre-Filter Specifications .....	198
Hand Priming Pump Specifications.....	199
Installation with Pre-filter .....	200
WIF (Water In Fuel) Sensor .....	201
Heater .....	202
Engine Wire Harness Connector Information .....	203



## Fuel Lines

### Fuel Line Installation Information

Connect the pre-filter and priming pump to the engine and fuel tank supply lines as shown below.  
Connect the fuel return line to the tank.

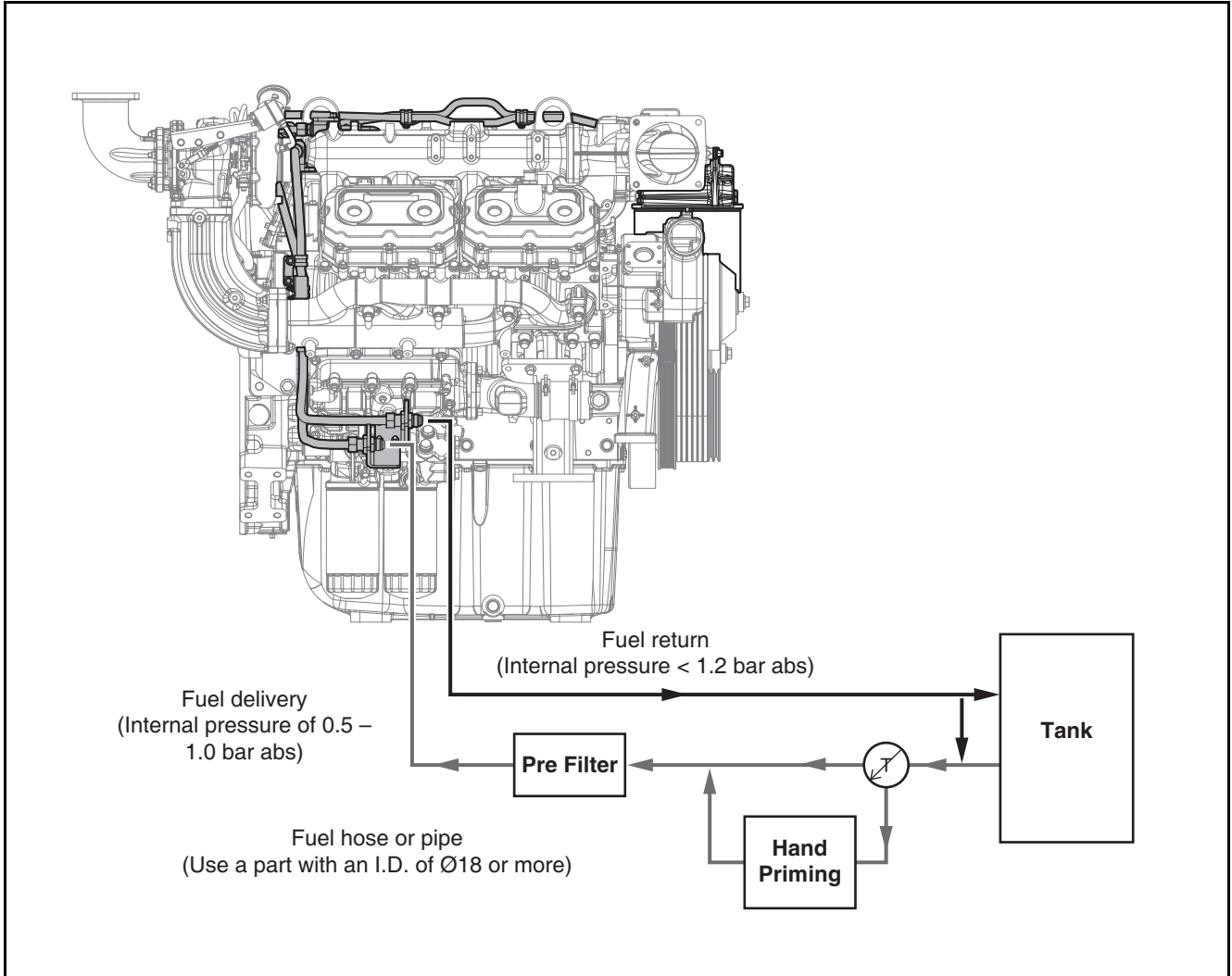

EDX15240097

# 13. Installation Guidelines

## Pre-Filter Specifications

Cummins FH386 (specifications changed from Fuel Pro to Diesel Pro.)

- Fuel Inlet/Outlet Port Hole Tap Spec (1/2-14 NPTF)

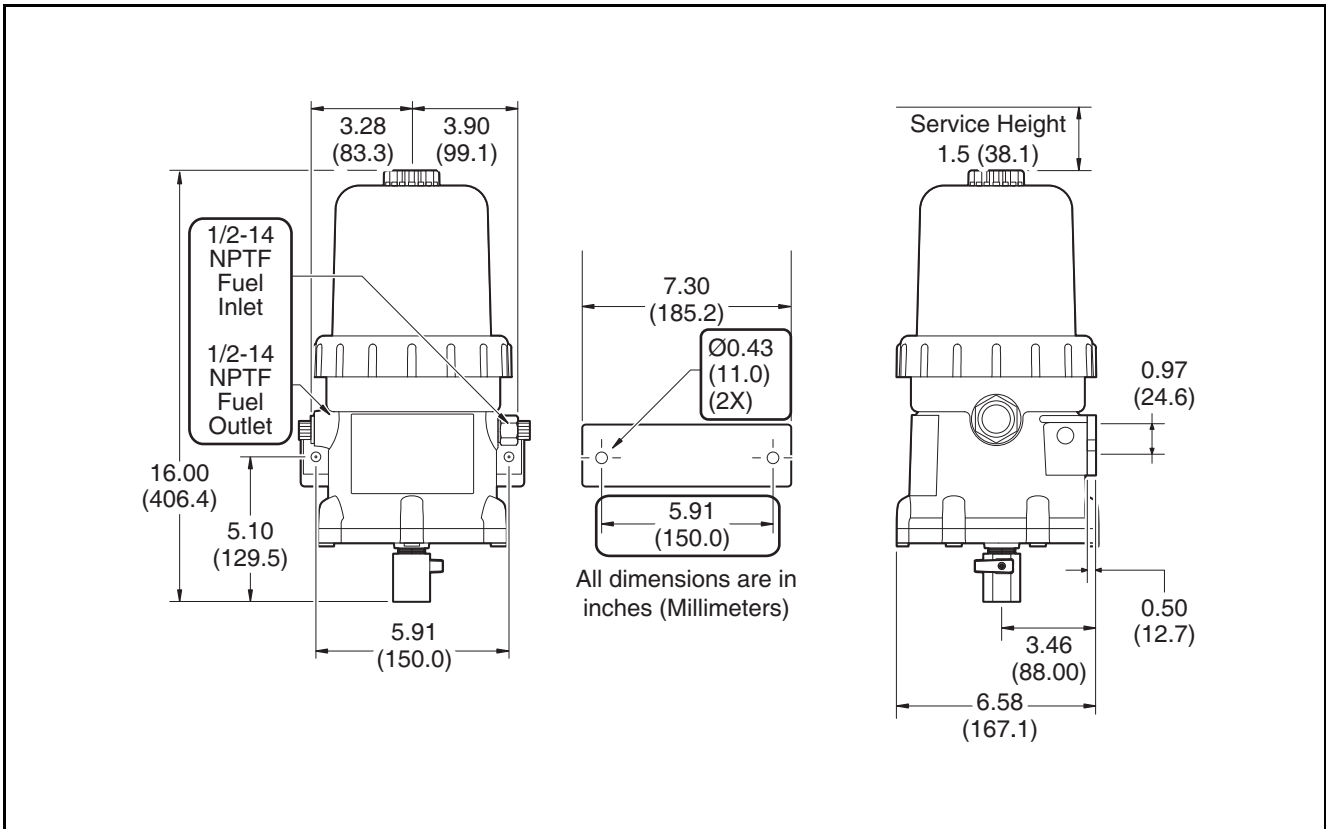

EDX22190137

# 13. Installation Guidelines

## Hand Priming Pump Specifications

Cummins LT36198

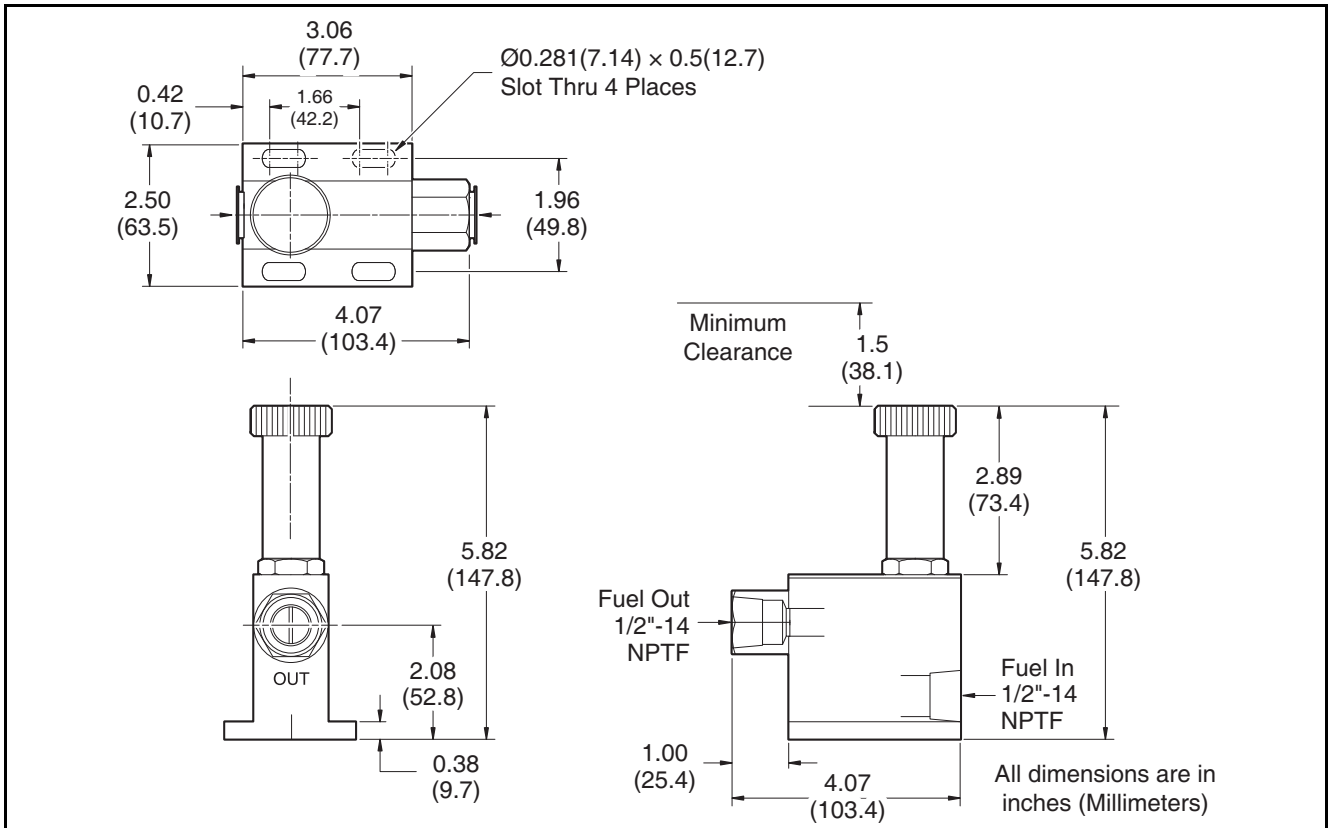

EDX22190138

# 13. Installation Guidelines

## Installation with Pre-filter

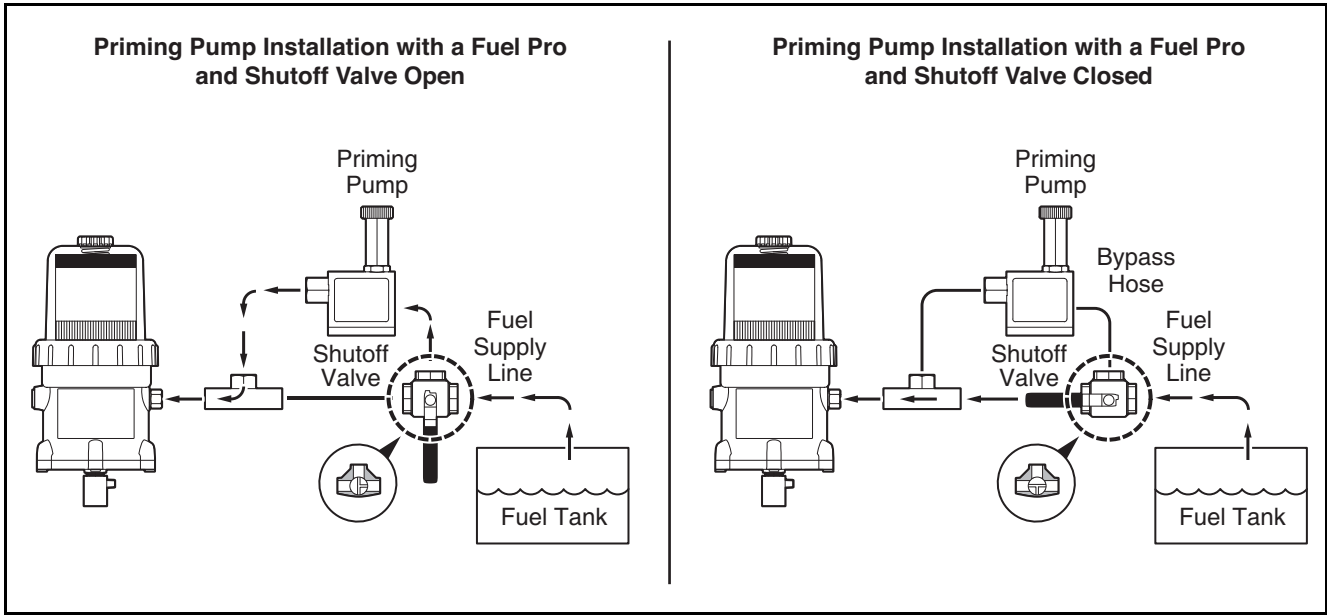

EDX22190139

- 1) Disconnect the fuel inlet line coming from the fuel tank to the pre-filter inlet.
- 2) Determine a suitable location to mount the priming pump. Note that a minimum clearance of 1.5 in. (38.1 mm) above the plunger is needed to operate the pump.
- 3) Once a desired location is selected, mark and drill four (4) 0.25 in. (6.4 mm) holes to mount the priming pump.
- 4) Using 0.25 in. (6.4 mm) bolts, washers, lock washers, and nuts, secure the priming pump.
- 5) Install shutoff valves (not included in the kit) into the inlet and outlet ports of the priming pump as shown.
- 6) Install a fuel supply line from the fuel tank to the shutoff valve.
- 7) Install a fuel line from the shutoff valve to the inlet of the priming pump.
- 8) Install a fuel line from the outlet of the priming pump to the Tee valve (not included in the kit) as shown.
- 9) Install a fuel line from the outlet of the Tee valve to the inlet of the pre-filter.
- 10) Remove the vent cap from the pre-filter.
- 11) Move the lever on the shutoff valve to the position shown.
- 12) Cycle the hand primer until the pre-filter is full of fuel.
- 13) Move the lever on the shutoff valve to the closed position.
- 14) Reinstall the vent cap on the fuel processor.
- 15) Start the engine. When the lubrication system reaches normal operating pressure, increase the RPM for one minute. Slowly open the vent cap until the fuel level drops to one inch above the collar.
- 16) Hand tighten the vent cap.
- 17) Check for fuel leaks.
- 18) Installation is complete.

# 13. Installation Guidelines

## WIF (Water In Fuel) Sensor

Circuit Diagram : Working Voltage (5 VDC ~ 50 VDC)

### WIF Wiring

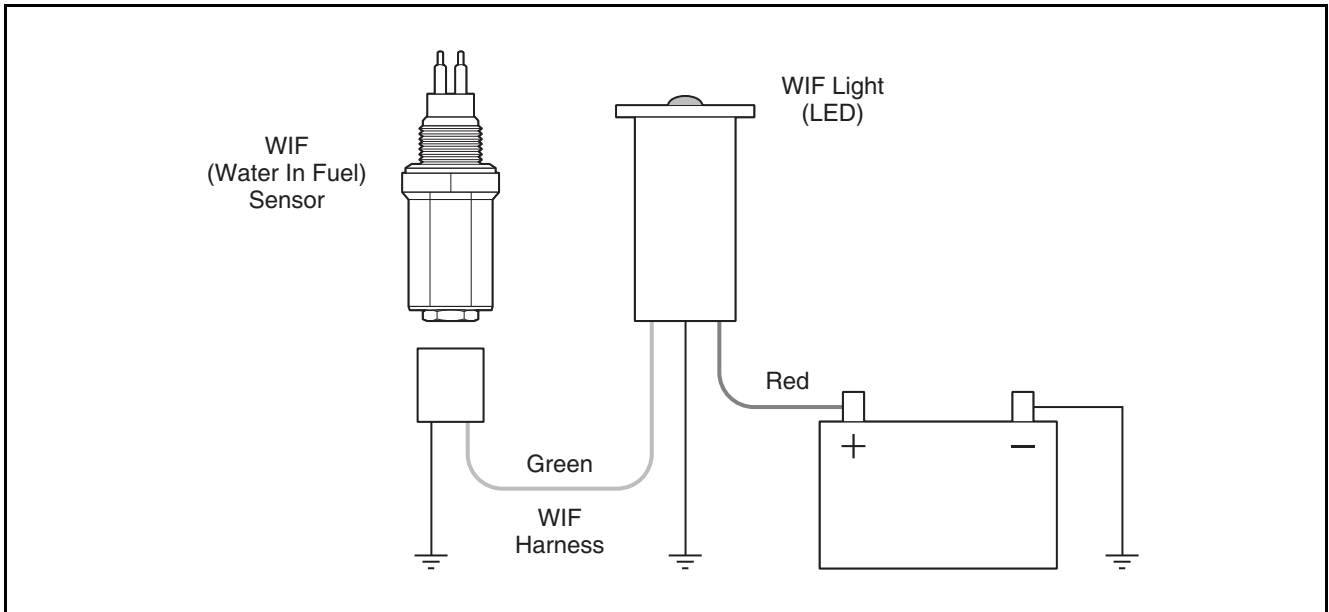

EDX22190141

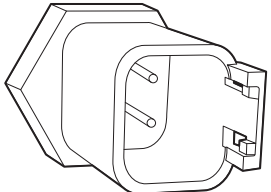
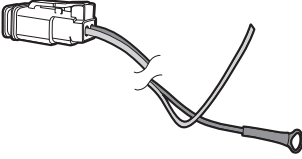
	Sensor Description	Note
	DEUTSCH DT13-2P	
	DEUTSCH DT06-2S for harness (Provided with the filter.)	Ground wire length (Black): 300 mm (11.8 in.) Signal wire length (green): 1800 mm (70.9 in.)

# 13. Installation Guidelines

## Heater

50 Hz heater 195 W x 2 assembled optionally with the pre-filter.

- Circuit Diagram: Voltage (24 VDC), Watt (195 W), Amps (4.5 A ±0.4 A)
- The bimetallic heater is connected to a separate on/off switch on the generator control panel and is used for cold starts.

## Fuse and Relay Connections

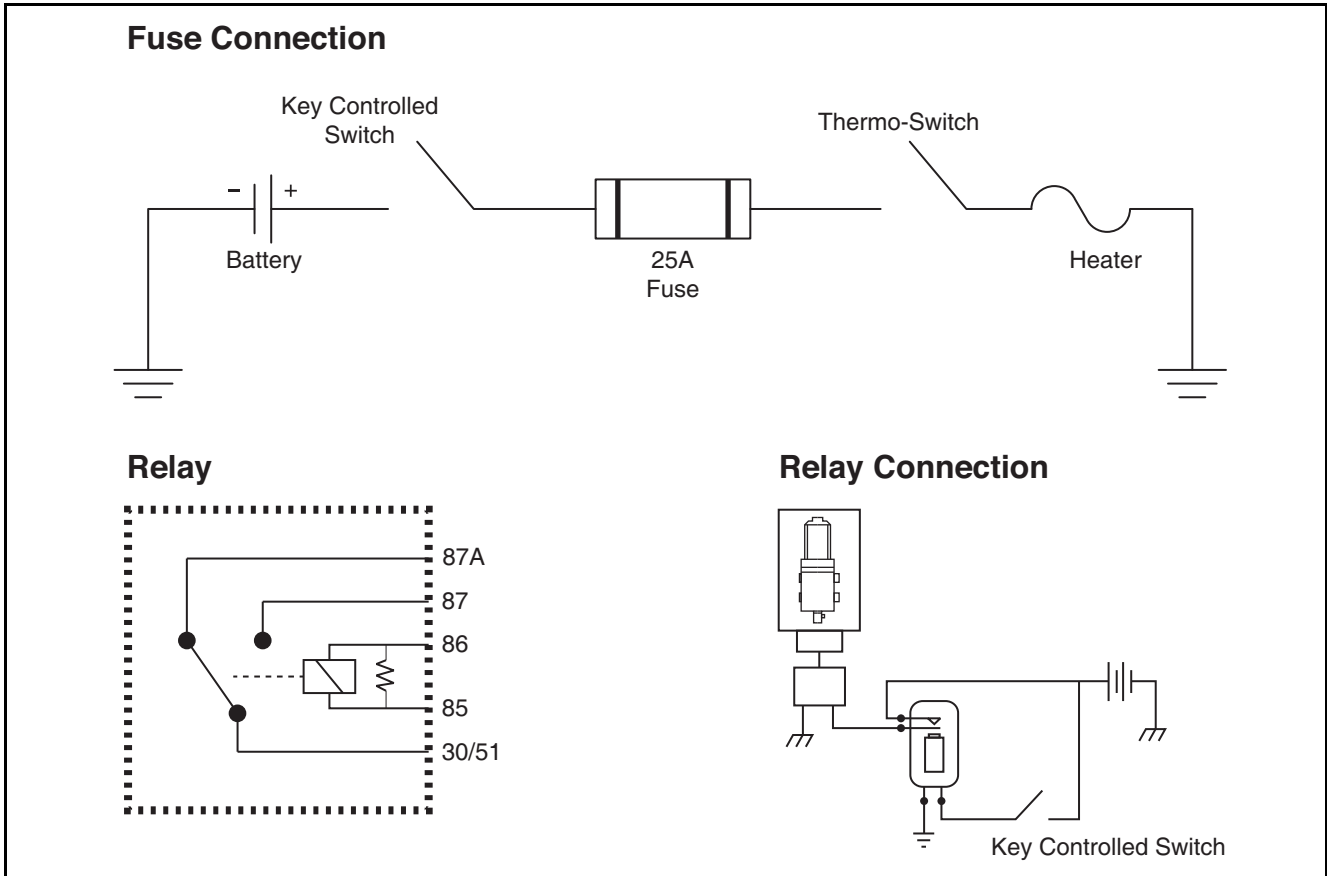

EDX22190144

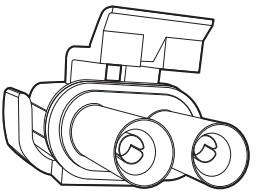
	Sensor Description	Note
	<p>Heater lead wire:            Connector Housing PACKARD #12103584            Pin PACKARD #12124581-L</p>	

## 13. Installation Guidelines

### Engine Wire Harness Connector Information

Refer to the engine wire harness connector pin information to connect the connectors to the generator control panel and check the communications.

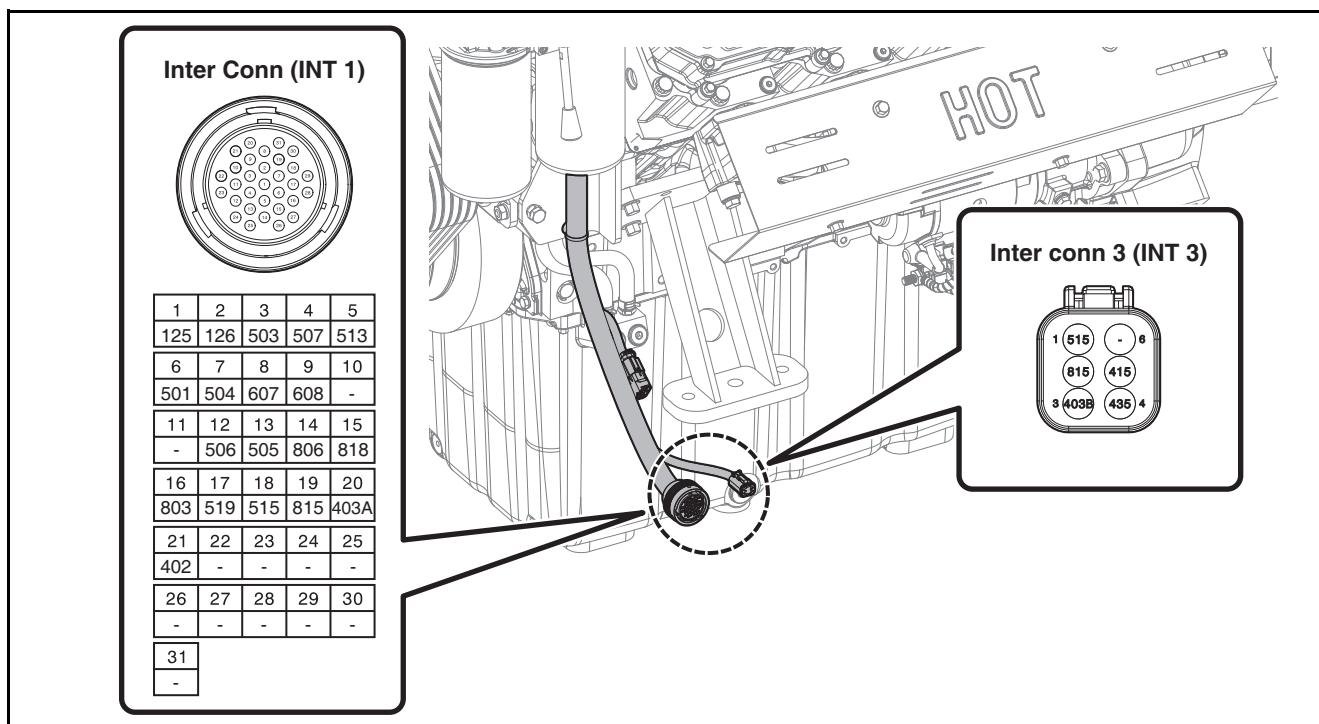

EDX15240020

\* Mating Connector (Air Heater)

Connector: Deutsch DT04-6P-CE02

Terminal: Deutsch 1060-16-0122

Circuit	Size (mm <sup>2</sup> )	Color	Insulation	Circuit Description	From	Pin
125	0.75	Y	FLR91X-A	EGT sensor LH signal	EGT sensor LH (EGTL)	2
126	0.75	B	FLR91X-A	EGT sensor LH GND	EGT sensor LH (EGTL)	1
503	1.5	G	FLR91X-A	TSO input	ECU 5 (5)	3
507	1.5	GrL	FLR91X-A T02	Starter relay high	ECU 5 (5)	7
513	1.5	GGr	FLR91X-A T02	Starter relay low	ECU 5 (5)	13
501	1.5	Y	FLR91X-A T01	CAN 1 low	ECU 5 (5)	1
504	1.5	G	FLR91X-A_T09	CAN 1 high	SP_09	
607	0.75	W	FLR91X-A T03	CAN 2 high	ECU 6 (6)	7
608	0.75	Y	FLR91X-A T03	CAN 2 low	ECU 6 (6)	8
506	1.5	G	FLR91X-A	Run lamp	ECU 5 (5)	6
505	1.5	Y	FLR91X-A	Wait to disconnect lamp	ECU 5 (5)	5
806	1.5	LW	FLR91X-A	Over speed lamp	ECU 8 (8)	6
818	1.5	Y	FLR91X-A	AUX input switch	ECU 8 (8)	18
803	1.5	G	FLR91X-A	Idle/run switch	ECU 8 (8)	3
519	0.75	W	FLR91X-A	50/60 Hz switch	ECU 5 (5)	19
515	1.5	RG	FLR91X-A	Switch battery output RH12	ECU 5 (5)	15
815	1.5	RV	FLR91X-A	Switch battery output RH33	ECU 8 (8)	15
403A	1.5	R	FLR91X-A	Air heater relay high/switch battery output RH21	SP_12	
402	1.5	Brn	FLR91X-A	Air heater relay low	ECU 4 (4)	2

# 13. Installation Guidelines

- Controller area network 1: ECU flash, for connecting to diagnostic tool
- Controller area network 2: For connecting to generator panel (engine control and monitoring)

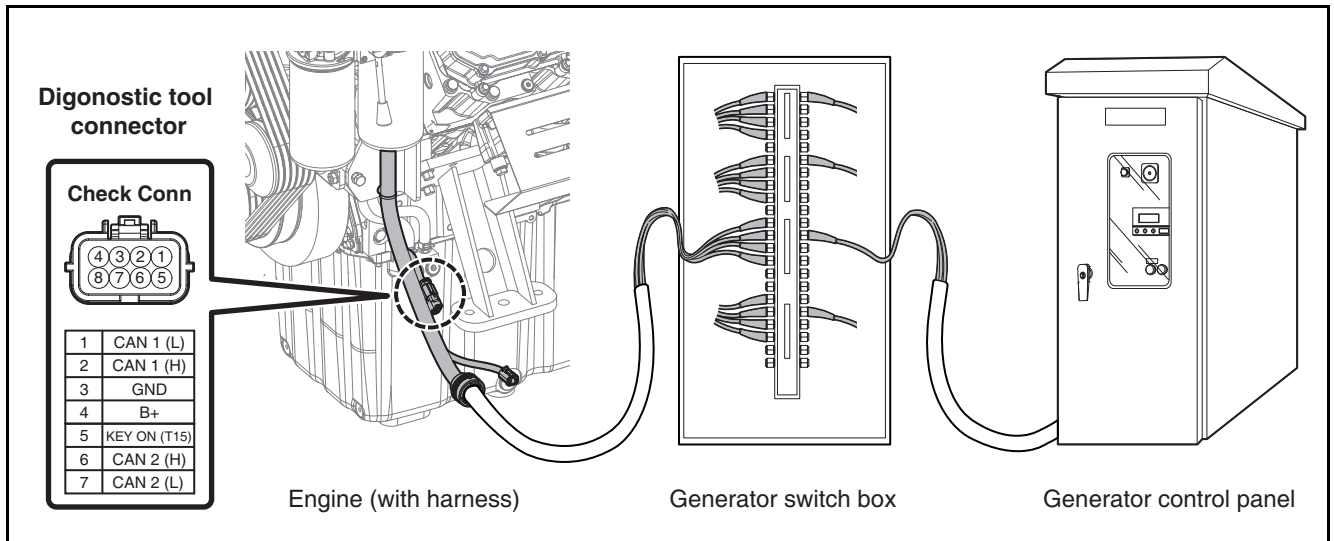

EDX15240022



